

ORDERING REPLACEMENT PARTS

To order replacement parts, contact the ICON Health & Fitness, Ltd. office, or write:

ICON Health & Fitness, Ltd.
Customer Service Department
Unit 4
Revie Road Industrial Estate
Revie Road
Beeston
Leeds, LS118JG
UK

Tel:

08457 089 009

Outside the UK: 0 (044) 113 387 7133
Fax: 0 (044) 113 387 7125

To help us assist you, please be prepared to give the following information:

- the MODEL NUMBER of the product (PFEVEX39831)
- the NAME of the product (PROFORM® 745 EKG exercise cycle)
- the SERIAL NUMBER of the product (see the front cover of this manual)
- the KEY NUMBER and DESCRIPTION of the part(s) (see page 22)



Class HC Fitness Product

Model No. PFEVEX39831
Serial No. _____

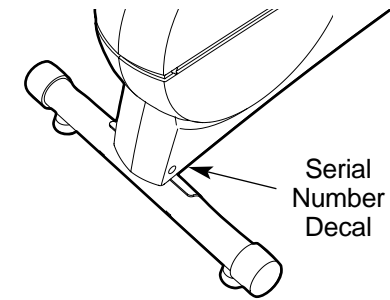

QUESTIONS?

As a manufacturer, we are committed to providing complete customer satisfaction. If you have questions, or if there are missing parts, please call:

08457 089 009

Or write:
ICON Health & Fitness, Ltd.
Customer Service Department
Unit 4
Revie Road Industrial Estate
Revie Road
Beeston
Leeds, LS118JG
UK

email: csuk@iconeurope.com

⚠ CAUTION

Read all precautions and instructions in this manual before using this equipment. Keep this manual for future reference.

USER'S MANUAL

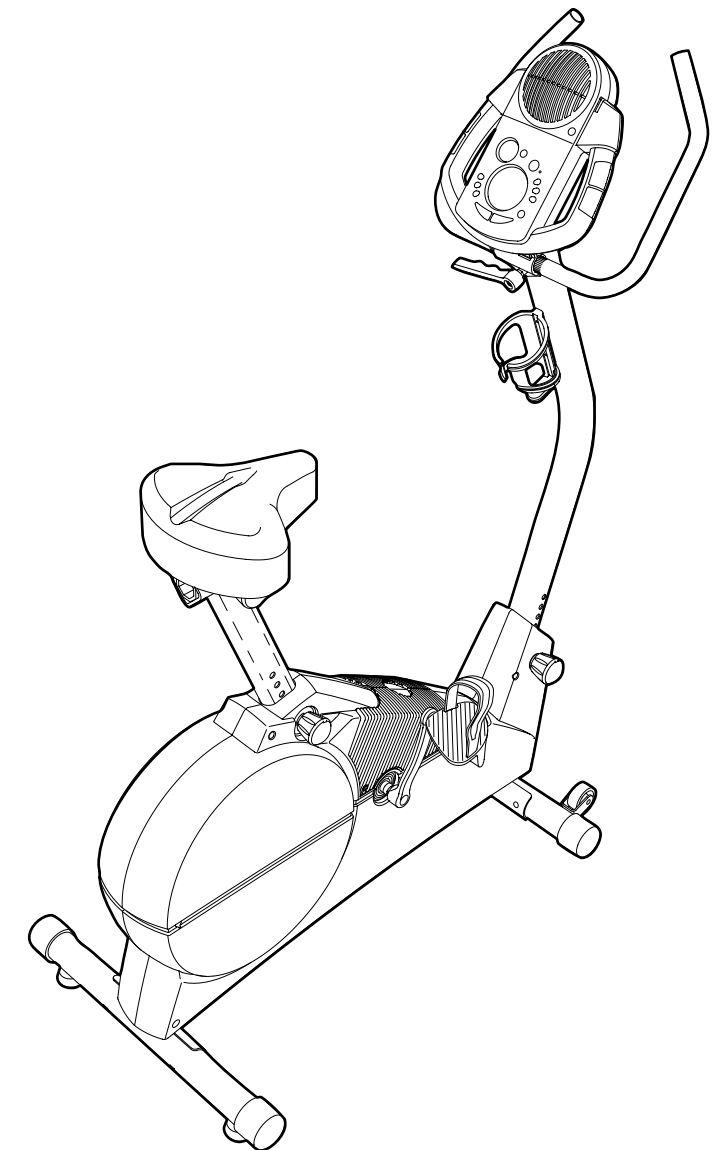

Visit our website at
www.iconeurope.com

TABLE OF CONTENTS

IMPORTANT PRECAUTIONS	3
BEFORE YOU BEGIN	4
ASSEMBLY	5
HOW TO OPERATE THE EXERCISE CYCLE	8
MAINTENANCE AND TROUBLESHOOTING	19
CONDITIONING GUIDELINES	20
PART LIST	22
EXPLODED DRAWING	23
ORDERING REPLACEMENT PARTS	Back Cover

EXPLODED DRAWING—Model No. PFEVEX39831

R1103A

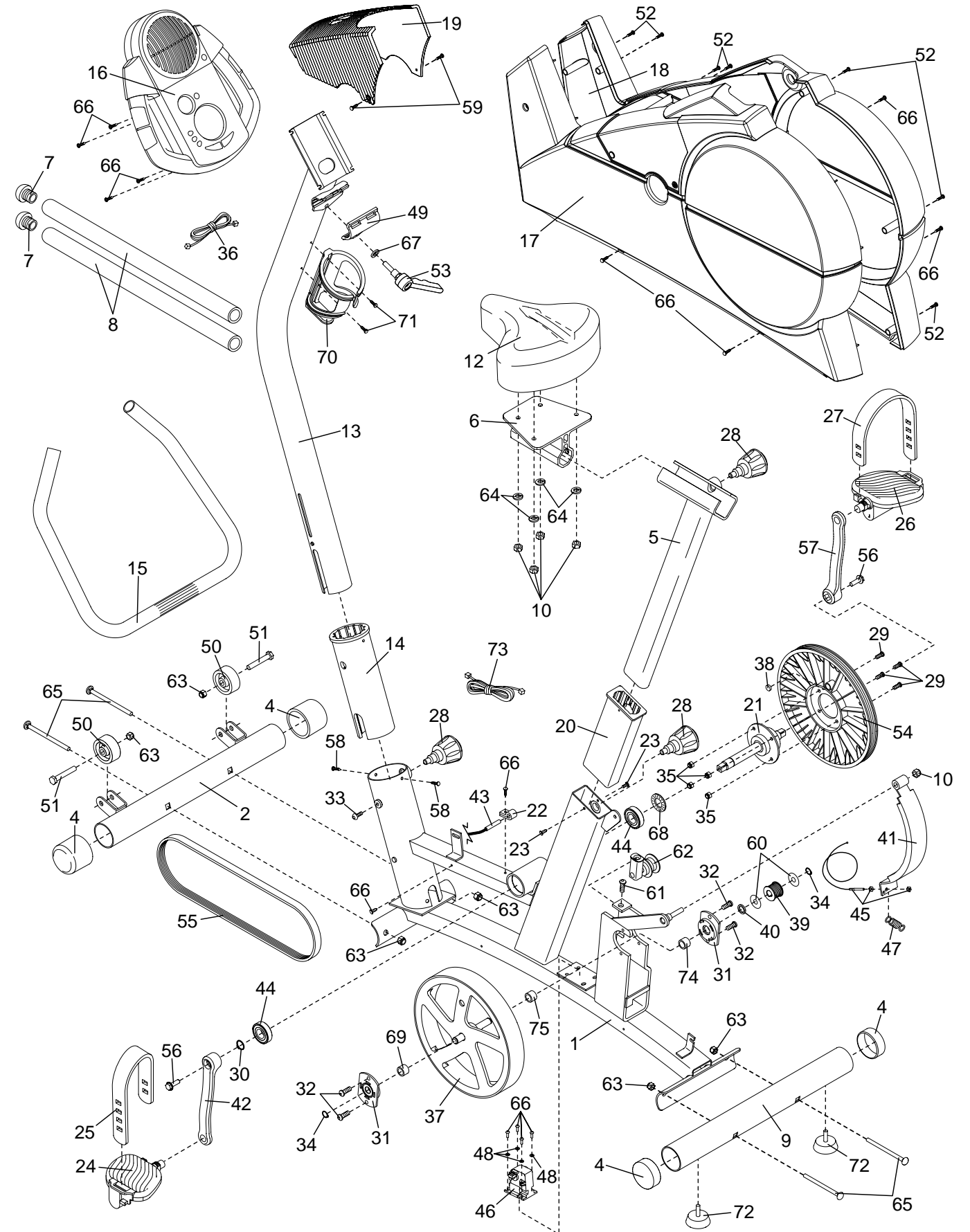

PART LIST—Model No. PFEVEX39831

R1103A

Key No.	Qty.	Description	Key No.	Qty.	Description
1	1	Frame	40	1	Flywheel Washer
2	1	Front Stabilizer	41	1	“C” Magnet
3	1	“C” Magnet Bracket	42	1	Left Crank Arm
4	4	Stabilizer Endcap	43	1	Reed Switch Wire
5	1	Seat Post	44	2	Crank Bearing
6	1	Seat Bracket	45	1	Resistance Cable
7	2	Handlebar Endcap	46	1	Resistance Motor
8	2	Foam Grip	47	1	Return Spring
9	1	Rear Stabiliser	48	4	M5 Washer
10	5	M8 Nylon Locknut	49	1	Handlebar Clamp
11	1	M6 x 38mm Bolt	50	2	Wheel
12	1	Seat	51	2	M10 x 45mm Button Bolt
13	1	Upright	52	7	M4 x 25mm Screw
14	1	Upright Bushing	53	1	Adjustment Handle
15	1	Handlebar	54	1	Pulley
16	1	Console	55	1	Belt
17	1	Left Side Shield	56	2	Flange Screw
18	1	Right Side Shield	57	1	Right Crank Arm
19	1	Side Shield Cover	58	2	M6 x 8mm Screw
20	1	Seat Post Bushing	59	2	M4 x 12mm Round Head Screw
21	1	Crank Assembly	60	2	Small Pulley Washer
22	1	Reed Switch Clamp	61	1	M8 x 35mm Screw
23	2	M4 x 5mm Screw	62	1	Idler
24	1	Left Pedal	63	6	M10 Black Nylon Locknut
25	1	Left Pedal Strap	64	4	M8 Split Washer
26	1	Right Pedal	65	4	M10 x 65mm Carriage Bolt
27	1	Right Pedal Strap	66	15	M4 x 16mm Screw
28	3	Adjustment Knob	67	1	M8 Washer
29	4	M6 x 18mm Bolt	68	1	Thrust Washer
30	1	Snap Ring	69	1	7.5mm Spacer
31	2	Bushing Bracket	70	1	Water Bottle Holder
32	4	M6 x 13mm Button Screw	71	2	M4 x 22mm Screw
33	1	M6 x 25.4mm Button Screw	72	2	Leveling Pad
34	2	Small Snap Ring	73	1	Lower Wire Harness
35	4	M6 Nylon Locknut	74	1	2.8mm Spacer
36	1	Upper Wire Harness	75	1	9mm Spacer
37	1	Flywheel	#	1	User’s Manual
38	1	Magnet	#	2	Allen Wrench
39	1	Small Pulley	#	1	Adapter Bracket

Note: “#” indicates a non-illustrated part. Specifications are subject to change without notice. See the back cover of this manual for information about ordering replacement parts.

IMPORTANT PRECAUTIONS

⚠ WARNING: To reduce the risk of serious injury, read the following important precautions before using the exercise cycle.

1. Read all instructions in this manual before using the exercise cycle.
2. It is the responsibility of the owner to ensure that all users of the exercise cycle are adequately informed of all precautions. Use the exercise cycle only as described in this manual.
3. Use the exercise cycle indoors on a level surface. Keep the exercise cycle away from moisture and dust. Place a mat under the exercise cycle to protect the floor.
4. Inspect and properly tighten all parts regularly. Replace any worn parts immediately.
5. Keep children under the age of 12 and pets away from the exercise cycle at all times.
6. Wear appropriate clothing when exercising; do not wear loose clothing that could become caught on the exercise cycle. Always wear athletic shoes for foot protection.
7. The exercise cycle should not be used by persons weighing more than 115 kg (250 lbs.).
8. Always keep your back straight when using the exercise cycle; do not arch your back.
9. If you feel pain or dizziness while exercising, stop immediately and cool down.
10. The exercise cycle does not have a freewheel; the pedals will continue to move until the flywheel stops.
11. The pulse sensor is not a medical device. Various factors, including the user's movement, may affect the accuracy of heart rate readings. The pulse sensor is intended only as an exercise aid in determining heart rate trends in general.
12. The exercise cycle is intended for home use only. Do not use the exercise cycle in a commercial, rental, or institutional setting.
13. A warning decal has been placed on the exercise cycle in the location shown on page 4. If the decal is missing, or if it is not legible, please call our Customer Service Department at 0345-089009 to order a free replacement decal. Apply the decal in the location shown.

⚠ WARNING: Before beginning this or any exercise program, consult your physician. This is especially important for persons over the age of 35 or persons with pre-existing health problems. Read all instructions before using. ICON assumes no responsibility for personal injury or property damage sustained by or through the use of this product.

BEFORE YOU BEGIN

Congratulations for selecting the new PROFORM® 745 EKG exercise cycle. Cycling is one of the most effective exercises for increasing cardiovascular fitness, building endurance, and toning the entire body. The PROFORM® 745 EKG offers an impressive array of features to let you enjoy this healthful exercise in the convenience and privacy of your home.

For your benefit, read this manual carefully before you use the exercise cycle. If you have questions

after reading this manual, please call our Customer Service Department at **08457 089 009**. To help us assist you, please note the product model number and serial number before calling. The model number is PFEVEX39831. The serial number can be found on a decal attached to the exercise cycle (see the front cover of this manual).

Before reading further, please familiarize yourself with the parts that are labeled in the drawing below.

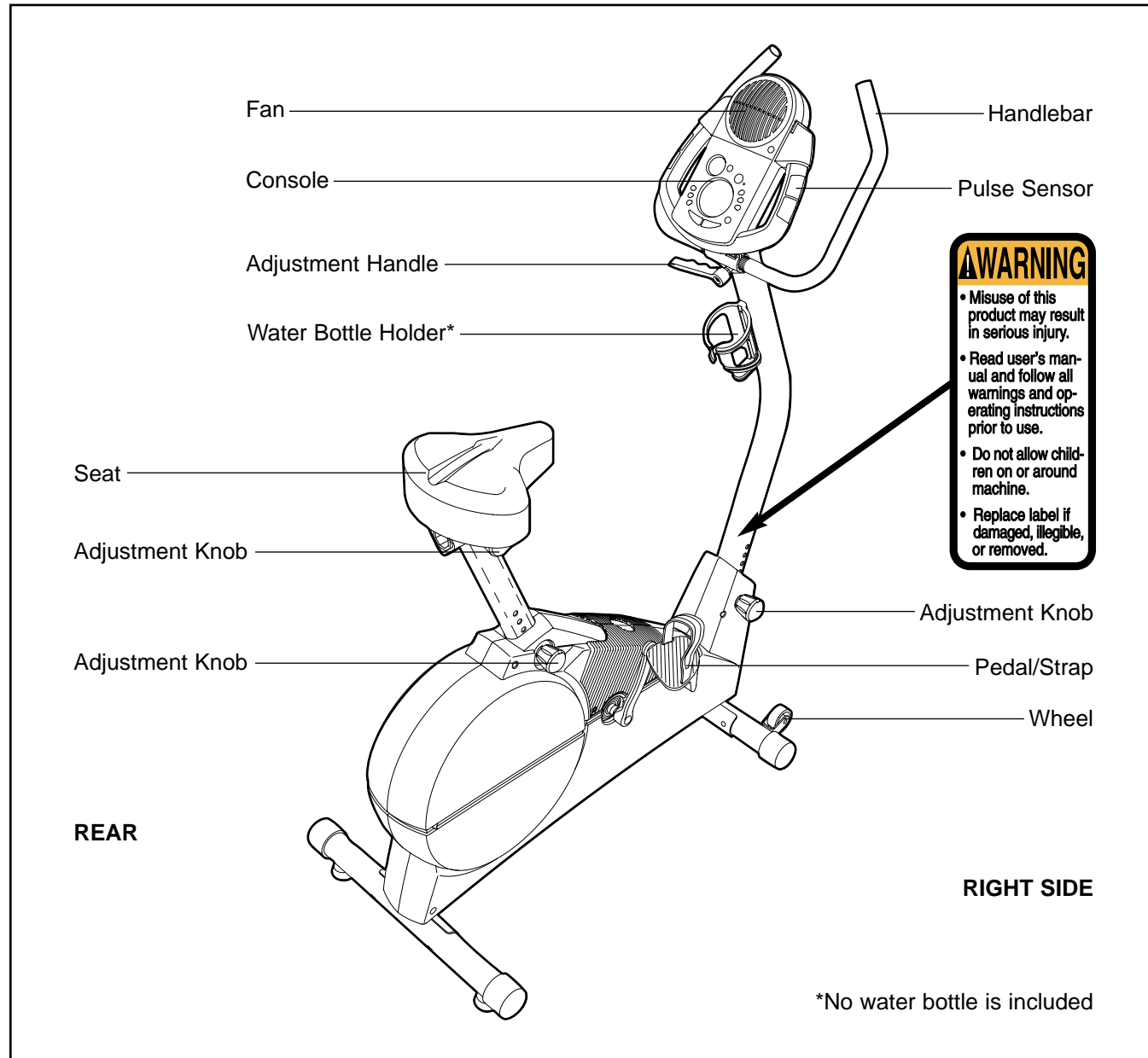

SUGGESTED STRETCHES

The correct form for several basic stretches is shown at the right. Move slowly as you stretch—never bounce.

1. Toe Touch Stretch

Stand with your knees bent slightly and slowly bend forward from your hips. Allow your back and shoulders to relax as you reach down toward your toes as far as possible. Hold for 15 counts, then relax. Repeat 3 times. Stretches: Hamstrings, back of knees and back.

2. Hamstring Stretch

Sit with one leg extended. Bring the sole of the opposite foot toward you and rest it against the inner thigh of your extended leg. Reach toward your toes as far as possible. Hold for 15 counts, then relax. Repeat 3 times for each leg. Stretches: Hamstrings, lower back and groin.

3. Calf/Achilles Stretch

With one leg in front of the other, reach forward and place your hands against a wall. Keep your back leg straight and your back foot flat on the floor. Bend your front leg, lean forward and move your hips toward the wall. Hold for 15 counts, then relax. Repeat 3 times for each leg. To cause further stretching of the achilles tendons, bend your back leg as well. Stretches: Calves, achilles tendons and ankles.

4. Quadriceps Stretch

With one hand against a wall for balance, reach back and grasp one foot with your other hand. Bring your heel as close to your buttocks as possible. Hold for 15 counts, then relax. Repeat 3 times for each leg. Stretches: Quadriceps and hip muscles.

5. Inner Thigh Stretch

Sit with the soles of your feet together and your knees outward. Pull your feet toward your groin area as far as possible. Hold for 15 counts, then relax. Repeat 3 times. Stretches: Quadriceps and hip muscles.

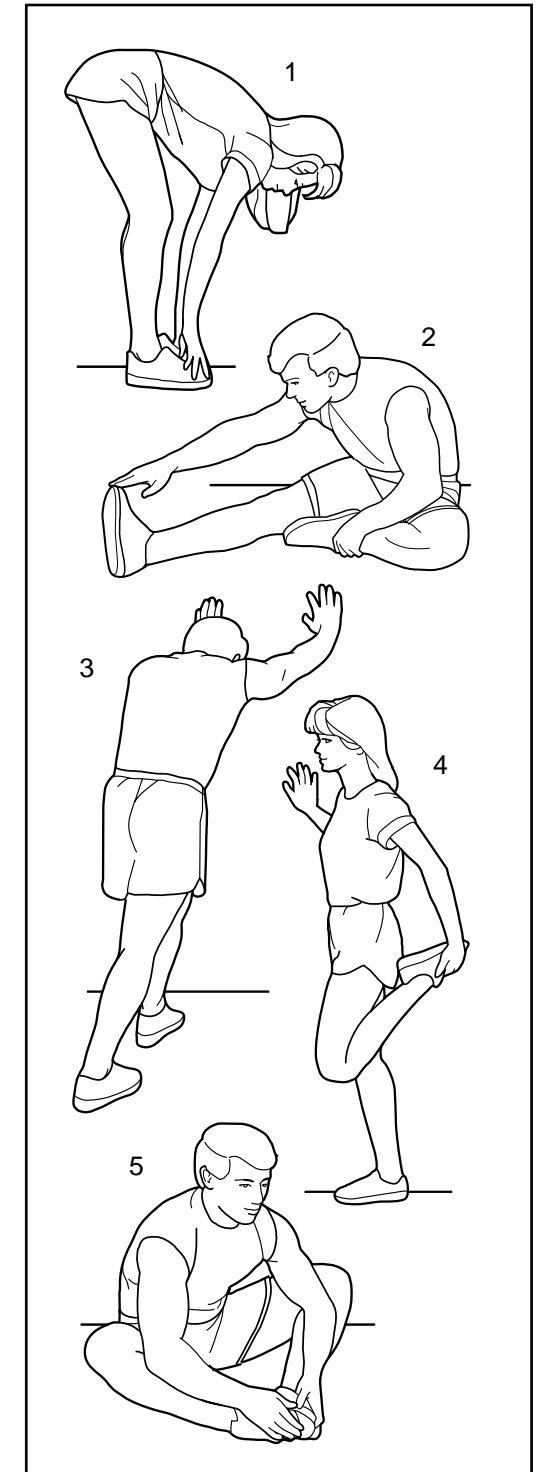

CONDITIONING GUIDELINES

The following guidelines will help you to plan your exercise program. Remember that proper nutrition and adequate rest are essential for successful results.

⚠️ WARNING:

- Before beginning this or any exercise program, consult your physician. This is especially important for persons over the age of 35 or persons with pre-existing health problems.
- The pulse sensor is not a medical device. Various factors may affect the accuracy of heart rate readings. The pulse sensor is intended only as an exercise aid in determining heart rate trends in general.

EXERCISE INTENSITY

Whether your goal is to burn fat or to strengthen your cardiovascular system, the key to achieving the desired results is to exercise with the proper intensity. The proper intensity level can be found by using your heart rate as a guide. The chart below shows recommended heart rates for fat burning, maximum fat burning, and cardiovascular (aerobic) exercise.

165	155	145	140	130	125	115	♥
145	138	130	125	118	110	103	♥
125	120	115	110	105	95	90	♥
20	30	40	50	60	70	80	

To find the proper heart rate for you, first find your age at the bottom of the chart (ages are rounded off to the nearest ten years). Next, find the three numbers above your age. The three numbers are your "training zone." The lowest number is the recommended heart rate for fat burning; the middle number is the recommended heart rate for maximum fat burning; the highest number is the recommended heart rate for aerobic exercise.

Fat Burning

To burn fat effectively, you must exercise at a relatively low intensity level for a sustained period of time.

During the first few minutes of exercise, your body uses easily accessible *carbohydrate* calories for energy. Only after the first few minutes of exercise does your body begin to use stored *fat* calories for energy. If your goal is to burn fat, adjust the intensity of your exercise until your heart rate is near the lowest number in your training zone as you exercise. For maximum fat burning, adjust the intensity of your exercise until your heart rate is near the middle number in your training zone as you exercise.

Aerobic Exercise

If your goal is to strengthen your cardiovascular system, your exercise must be "aerobic." Aerobic exercise is activity that requires large amounts of oxygen for prolonged periods of time. This increases the demand on the heart to pump blood to the muscles, and on the lungs to oxygenate the blood. For aerobic exercise, adjust the intensity of your exercise until your heart rate is near the highest number in your training zone.

WORKOUT GUIDELINES

Each workout should include the following three parts:

A warm-up, consisting of 5 to 10 minutes of stretching and light exercise. A proper warm-up increases your body temperature, heart rate, and circulation in preparation for exercise.

Training zone exercise, consisting of 20 to 30 minutes of exercising with your heart rate in your training zone. Note: During the first few weeks of your exercise program, do not keep your heart rate in your training zone for longer than 20 minutes.

A cool-down, with 5 to 10 minutes of stretching. This will increase the flexibility of your muscles and will help to prevent post-exercise problems.

EXERCISE FREQUENCY

To maintain or improve your condition, plan three workouts each week, with at least one day of rest between workouts. After a few months of regular exercise, you may complete up to five workouts each week, if desired. Remember, the key to success is make exercise a regular and enjoyable part of your everyday life.

ASSEMBLY

Assembly requires two persons. Place all parts of the exercise cycle in a cleared area and remove the packing materials. Do not dispose of the packing materials until assembly is completed.

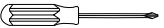
Assembly requires the included tools and your own adjustable spanner  **and Phillips screwdriver** .

Use the part drawings below to identify the small parts used in assembly. The number in parenthesis below each drawing refers to the key number of the part, from the PART LIST on page 22. The second number refers to the quantity needed for assembly. **Note: Some small parts may have been pre-attached for shipping. If a part is not in the parts bag, check to see if it has been pre-attached.**

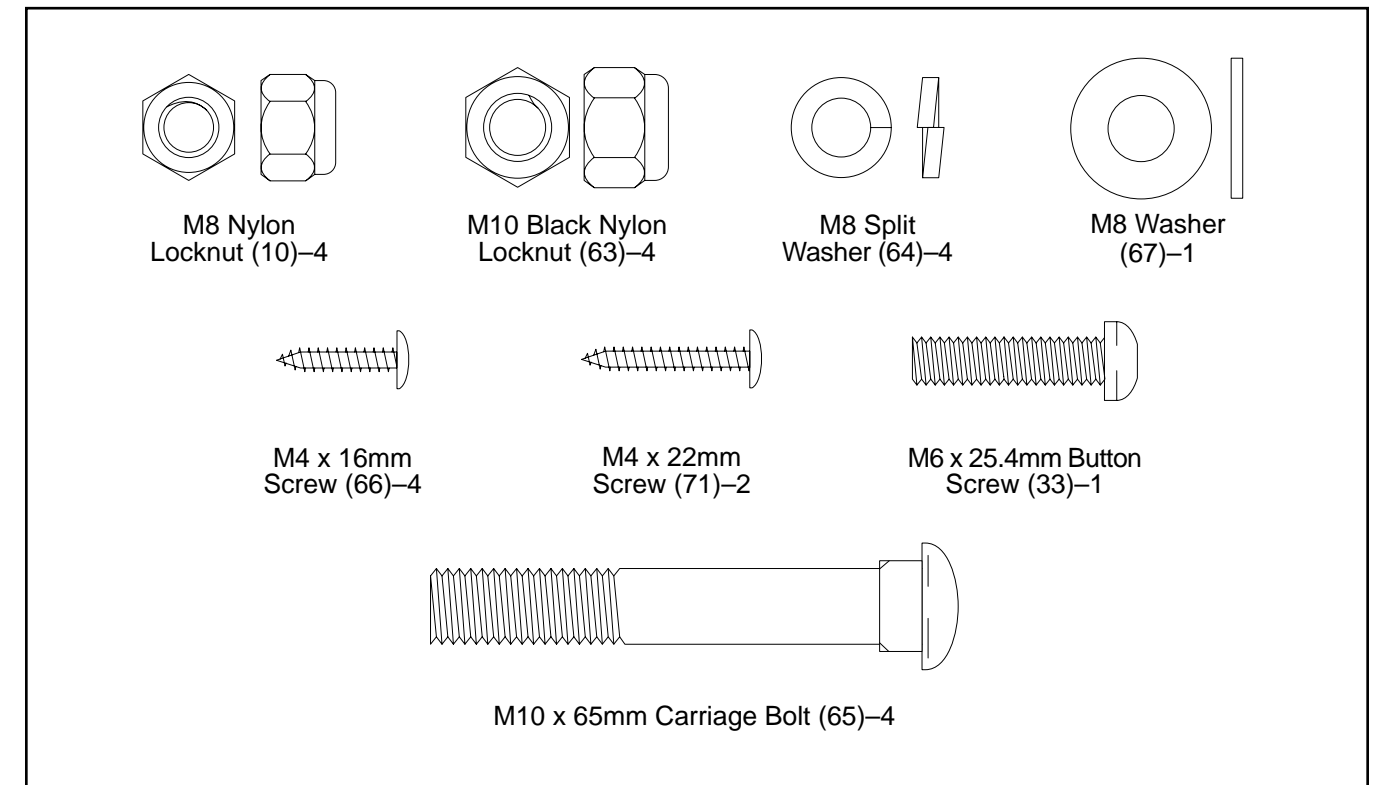

1. Identify the Front Stabiliser (2). While another person lifts the front of the Frame (1) slightly, attach the Front Stabilizer to the Frame with two M10 x 65mm Carriage Bolts (65) and two M10 Black Nylon Locknuts (63). **Make sure that the Front Stabiliser is turned so the Wheels (50) are not touching the floor.**

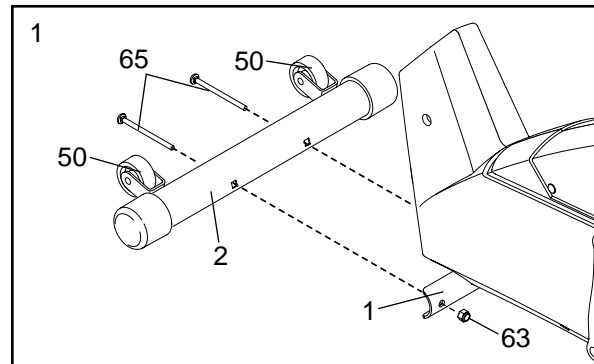

2. While another person lifts the back of the Frame (1) slightly, attach the Rear Stabilizer (9) to the Frame with two M10 x 65mm Carriage Bolts (65) and two M10 Black Nylon Locknuts (63).

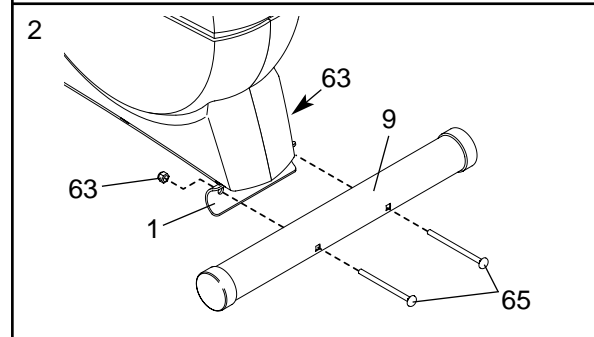

3. While another person holds the Upright (13) in the position shown, connect the Upper Wire Harness (36) to the Lower Wire Harness (73).

Turn the indicated Adjustment Knob (28) counterclockwise two or three turns to loosen it. Next, pull the Knob, insert the Upright (13) into the Frame (1), and then release the Knob. **Be careful to avoid pinching the Wire Harnesses (36, 73). Move the Upright up and down slightly until the pin on the Knob snaps into one of the holes in the Upright.** Then, turn the Knob clockwise until it is tight.

Tighten the M6 x 25.4mm Button Screw (33) into the Frame (1) and into the slot in the side of the Upright (13).

Attach the Water Bottle Holder (70) to the Upright (13) with two M4 x 22mm Screws (71).

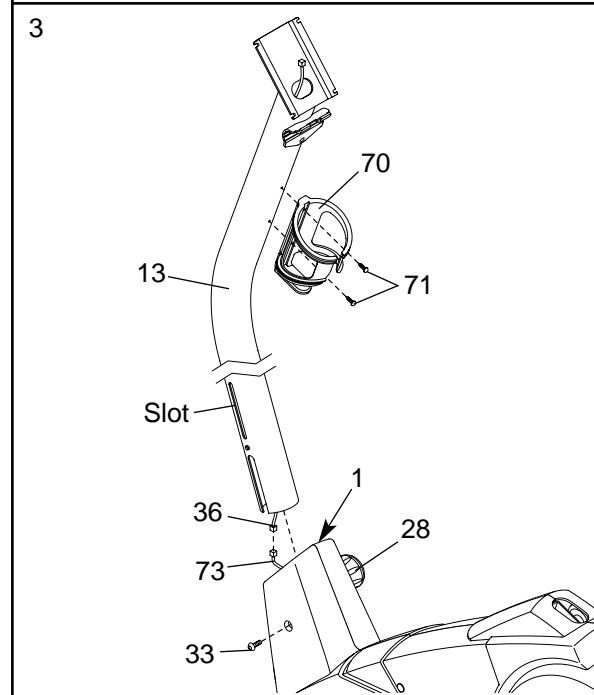

4. The Console (16) requires four "D" batteries (not included); alkaline batteries are recommended. Remove the screw from the battery drawer. Pull the battery drawer open and insert four batteries. **Make sure that the batteries are oriented as shown by the markings inside the battery drawer.** Close the battery drawer and reattach the screw. Note: When the batteries are installed correctly, the fan will turn on for a moment.

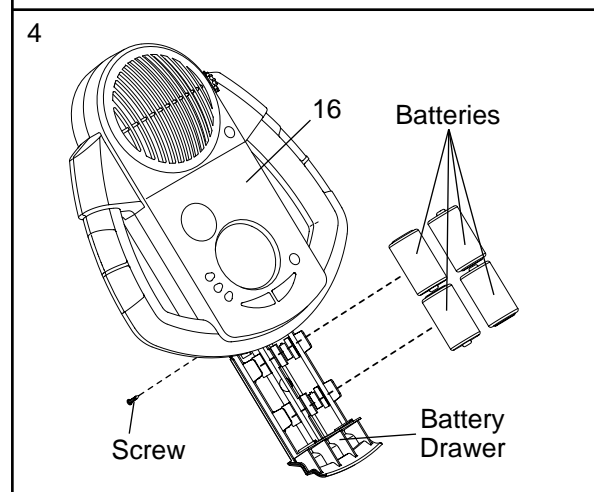

MAINTENANCE AND TROUBLESHOOTING

Inspect and tighten all parts of the exercise cycle regularly. Replace any worn parts immediately.

To clean the exercise cycle, use a damp cloth and a small amount of mild detergent. **Important: To avoid damage to the console, keep liquids away from the console and keep the console out of direct sunlight.**

HANDGRIP PULSE SENSOR TROUBLESHOOTING

- Avoid moving your hands or holding the metal contacts too tightly whilst using the handgrip pulse sensor. Excessive movement or pressure may interfere with heart rate readings.
- For the most accurate heart rate reading, hold the metal contacts for about 15 seconds.
- Keep the metal contacts clean. The contacts can be cleaned with a soft cloth—never use alcohol, abrasives, or chemicals.

HOW TO ADJUST THE REED SWITCH

If the console does not display correct feedback, the reed switch should be adjusted. In order to adjust the reed switch, the Left Side Shield (17) must be removed. Remove the seven Screws (52) from the Right Side Shield (18). Next, remove the Screw (59) from the right side of the Side Shield Cover (19).

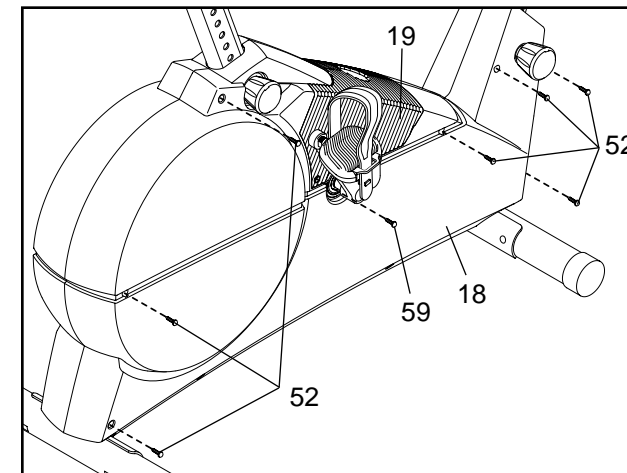

Using an adjustable wrench, turn the Left Pedal (24) clockwise and remove it. Next, remove the two Screws (66) from the Left Side Shield (17). Remove the Screw (59) from the left side of the Side Shield Cover (19) and lift it off. Gently remove the Left Side Shield.

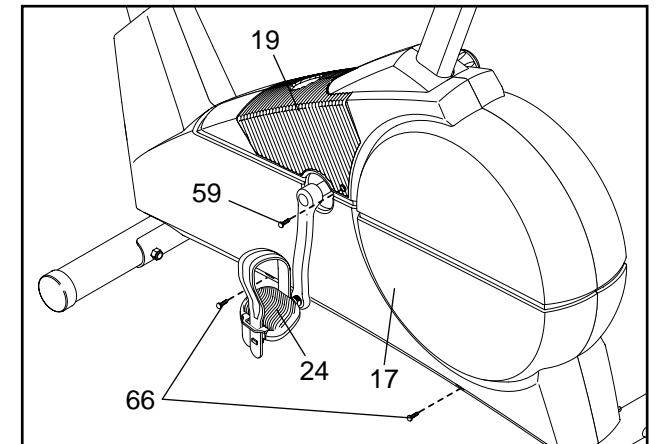

Next, locate the Reed Switch (43). Turn the Left Crank Arm (42) until the Magnet (38) is aligned with the Reed Switch. Loosen but do not remove the Screw (66). Slide the Reed Switch slightly closer to or away from the Magnet. Retighten the Screw. Turn the Crank for a moment. Repeat until the console displays correct feedback. When the Reed Switch is correctly adjusted, reattach the left side shield, side shield cover and the pedal.

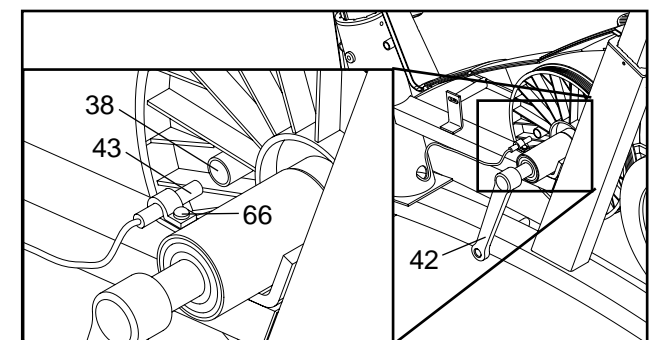

BATTERY REPLACEMENT

If the console display becomes dim, the batteries should be replaced; most console problems are the result of low batteries. See assembly step 4 on page 6 for replacement instructions.

HOW TO USE PROGRAMS DIRECTLY FROM OUR WEB SITE

Our Web site at www.iFIT.com allows you to play iFIT.com programs directly from the internet. To use programs from our Web site, the exercise cycle must be connected to your home computer. See HOW TO CONNECT YOUR COMPUTER on page 15. In addition, you must have an internet connection and an internet service provider. A list of specific system requirements will be found on our Web site.

Follow the steps below to use a program from our Web site.

1 Turn on the console.

See step 1 on page 11.

2 Select the iFIT.com mode.

Each time the console is turned on, the manual mode will be selected. To select the iFIT.com mode, press the iFIT.com button. The indicator near the button will light and the letters IF will appear in the small display.

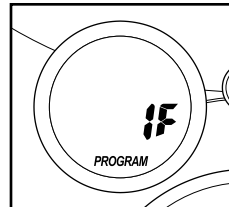

3 Go to your computer and start an internet connection.

4 Start your Web browser, if necessary, and go to our Web site at www.iFIT.com.

5 Follow the desired links on our Web site to select a program.

6 Follow the on-line instructions to start the program.

When you start the program, an on-screen count-down will begin.

7 Return to the exercise cycle and begin pedaling.

When the on-screen countdown ends, the program will begin. The program will function in almost the same way as a Smart program (see step 3 on page 13). However, an electronic "chirping" sound will alert you when the resistance level and/or the target pace is about to change.

8 Follow your progress with the large display.

See step 4 on page 11.

9 Measure your heart rate if desired.

See step 5 on page 12.

10 When you are finished exercising, the console will automatically turn off.

See step 7 on page 12.

- Slide the two slots in the Handlebar Clamp (49) onto the two indicated tabs on the Upright (13). Lift the bottom of the Handlebar Clamp away from the Upright, and insert the Handlebar (15) between the Handlebar Clamp and the Upright. Centre the Handlebar and rotate it to the desired position.

Slide an M8 Washer (67) onto the Adjustment Handle (53). Insert the Adjustment Handle into the Handlebar Clamp (49) and tighten the Adjustment Handle into the Upright (13). Note: The Adjustment Handle works like a spanner. Turn the Handle clockwise, pull it away from the Upright, turn it counterclockwise, push it toward the upright, and then turn it clockwise again.

- Hold the Console (16) near the Upright (13). Connect the console wire to the Upper Wire Harness (36). Insert the excess wire into the Upright.

Attach the Console (16) to the Upright (13) with four M4 x 16mm Screws (66). **Be careful to avoid pinching the wires.**

- Turn the indicated Adjustment Knob (28) counterclockwise two or three turns to loosen it. Next, pull the Knob, insert the Seat Post (5) into the Frame (1), and then release the Knob. **Move the Seat Post up and down slightly until the pin on the Knob snaps into one of the holes in the Seat Post.** Then, turn the Knob clockwise until it is tight.

- Attach the Seat (12) to the Seat Bracket (6) with four M8 Nylon Locknuts (10) and four M8 Split Washers (64). Note: The Nylon Locknuts and the Split Washers may be pre-attached to the underside of the Seat.

Turn the Adjustment Knob (28) counterclockwise two or three turns to loosen it. Next, pull the Knob, slide the Seat Bracket (6) into the top of the Seat Post (5), and then release the Knob. **Move the Seat Bracket forward and backward slightly until the pin on the Knob snaps into one of the holes in the Seat Bracket.** Then, turn the Knob clockwise until it is tight. Note: If desired, you can attach your own seat to the exercise cycle using the Adapter Bracket (not shown) in place of the Seat (12) and the Seat Bracket.

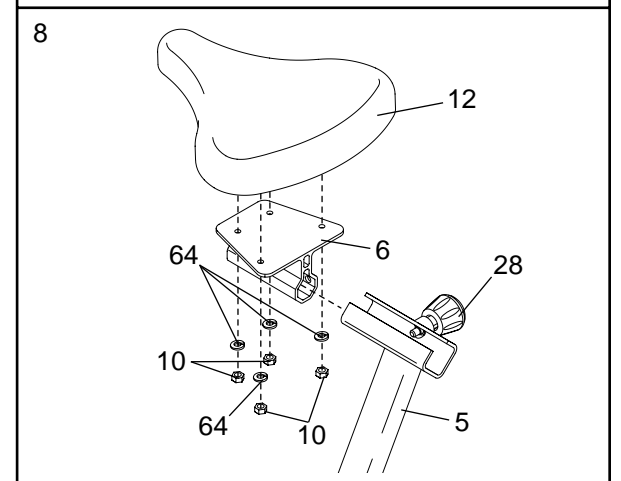
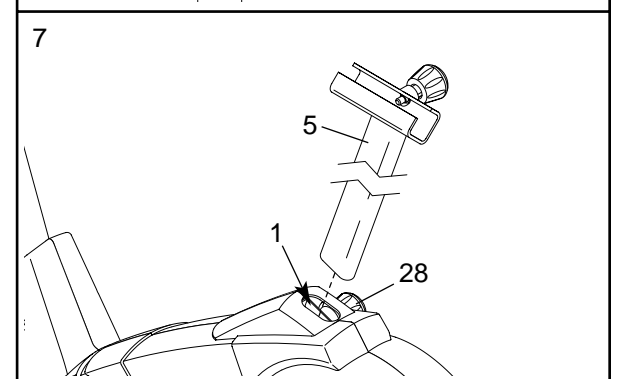
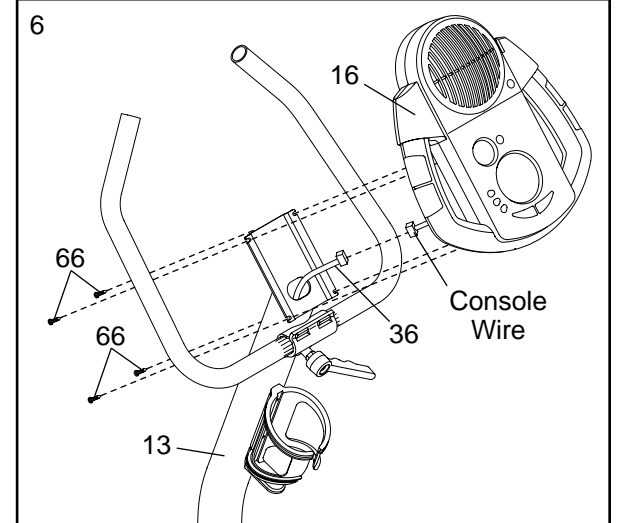
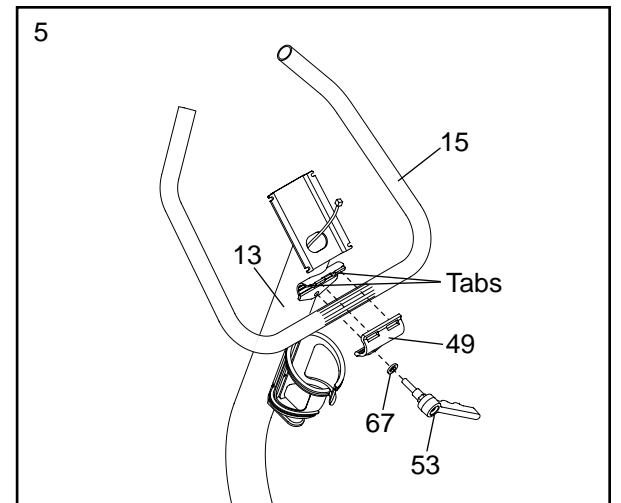

9. Identify the Left Pedal (24), which is marked with an "L." Using an adjustable wrench, **firmly tighten** the Left Pedal *counterclockwise* into the Left Crank Arm (42). Tighten the Right Pedal (not shown) *clockwise* into the Right Crank Arm. **Important: Tighten both Pedals as firmly as possible. After using the exercise cycle for one week, retighten the Pedals. For best performance, the Pedals must be kept tightened.**

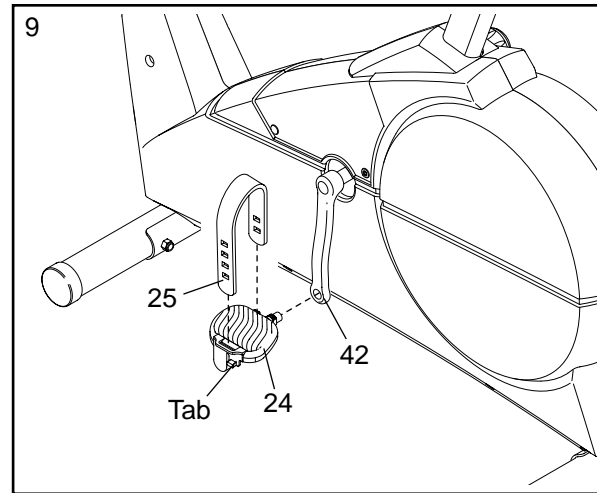

Adjust the Left Pedal Strap (25) to the desired position, and press the end of the Pedal Strap onto the tab on the Left Pedal (24). Adjust the Right Pedal Strap (not shown) in the same way.

10. **Make sure that all parts are properly tightened before you use the exercise cycle.** Note: After assembly is completed, some extra parts may be left over. Place a mat beneath the exercise cycle to protect the floor.

HOW TO OPERATE THE EXERCISE CYCLE

HOW TO ADJUST THE SEAT POST

For effective exercise, the seat should be at the proper height. As you pedal, there should be a slight bend in your knees when the pedals are in the lowest position. To adjust the height of the seat, first turn the indicated knob

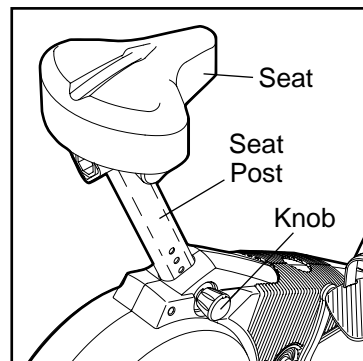

counterclockwise two or three turns to loosen it (if the knob is not loosened enough, it may scratch the seat post). Next, pull the knob, slide the seat post to the desired height, and then release the knob. **Move the seat post up and down slightly until the pin on the knob snaps into one of the holes in the seat post.** Then, turn the knob clockwise until it is tight.

HOW TO ADJUST THE SEAT

The seat can be adjusted to the position that is the most comfortable for you. **Before adjusting the seat, dismount the exercise cycle; do not adjust the seat while you are sitting on it.** To adjust the seat, first turn the indicated knob counterclockwise two or three turns to loosen it (if the knob is not loosened enough, it may scratch the seat bracket). Next, pull the knob, slide the seat to the desired position, and then release the knob. **Move the seat bracket forward and backward slightly until the pin on the knob snaps into one of the holes in the seat bracket.** Then, turn the knob clockwise until it is tight.

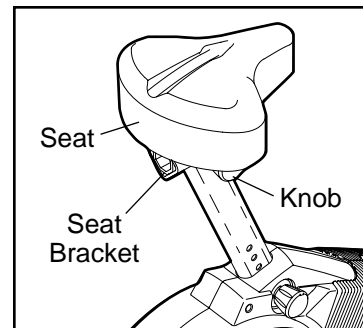

HOW TO USE iFIT.COM CD AND VIDEO PROGRAMS

To use iFIT.com CDs or videocassettes, the exercise cycle must be connected to your portable CD player, portable stereo, home stereo, computer with CD player, or VCR. See HOW TO CONNECT YOUR CD PLAYER, VCR, OR COMPUTER on page 14. **To purchase iFIT.com CDs and videocassettes, visit our Web site at www.iFIT.com.**

Follow the steps below to use an iFIT.com CD or video program.

- 1 Turn on the console.**
See step 1 on page 11.

- 2 Select the iFIT.com mode.**

Each time the console is turned on, the manual mode will be selected. To select the iFIT.com mode, press the iFIT.com button. The indicator near the button will light and the letters IF will appear in the small display.

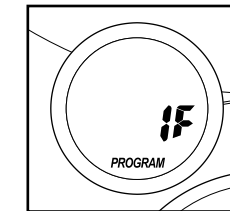

- 3 Insert the iFIT.com CD or videocassette.**

If you are using an iFIT.com CD, insert the CD into your CD player. If you are using an iFIT.com videocassette, insert the videocassette into your VCR.

- 4 Press the play button on your CD player or VCR.**

A moment after the play button is pressed, your personal trainer will begin guiding you through your workout. Simply follow your personal trainer's instructions.

The program will function in almost the same way as a Smart program (see step 3 on page 13). However, an electronic "chirping" sound will alert you when the resistance level and/or the target pace is about to change.

Note: If the resistance of the pedals and/or the target pace does not change when a "chirp" is heard:

- **Make sure that the indicator near the iFIT.com button is lit.**
- **Adjust the volume of your CD player or VCR. If the volume is too high or too low, the console may not detect the program signals.**
- **Make sure that the audio cable is properly connected and that it is fully plugged in.**

- 5 Follow your progress with the large display.**

See step 4 on page 11.

- 6 Measure your heart rate if desired.**

See step 5 on page 12.

- 7 Turn on the fan if desired.**

See step 6 on page 12.

- 8 When you are finished exercising, the console will automatically turn off.**

See step 7 on page 12.

HOW TO CONNECT YOUR VCR

Note: If your VCR has an unused AUDIO OUT jack, see instruction A below. If the AUDIO OUT jack is being used, see instruction B. If you have a TV with a built-in VCR, see instruction B. If your VCR is connected to your home stereo, see HOW TO CONNECT YOUR HOME STEREO on page 15.

A. Plug one end of the audio cable into the jack beneath the console. Plug the other end of the audio cable into the adapter. Plug the adapter into the AUDIO OUT jack on your VCR.

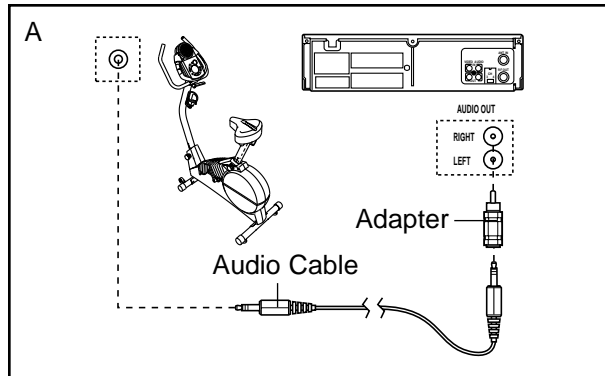

B. Plug one end of the audio cable into the jack beneath the console. Plug the other end of the audio cable into the adapter. Plug the adapter into an RCA Y-adaptor (available at electronics stores). Next, remove the wire that is currently plugged into the AUDIO OUT jack on your VCR and plug the wire into the unused side of the Y-adaptor. Plug the Y-adaptor into the AUDIO OUT jack on your VCR.

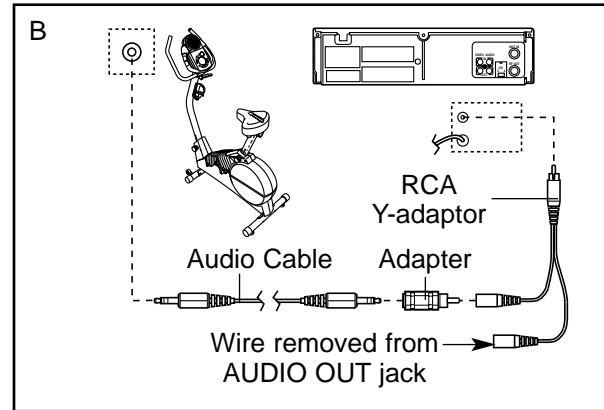

HOW TO ADJUST THE UPRIGHT

The upright can be adjusted to the height that is the most comfortable for you. To adjust the upright, first turn the indicated knob counterclockwise two or three turns to loosen it (if the knob is not loosened enough, it may scratch the upright). Next, pull the knob, slide the upright to the desired height, and then release the knob. **Move the upright up and down slightly until the pin on the knob snaps into one of the holes in the upright.** Then, turn the knob clockwise until it is tight.

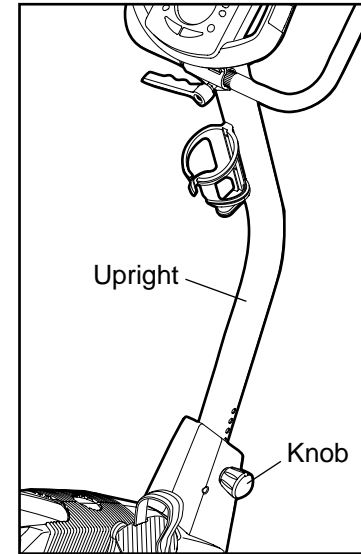

HOW TO ADJUST THE PEDAL STRAPS

See assembly step 9 on page 8 to adjust the pedal straps.

HOW TO ADJUST THE HANDLEBAR

The handlebar can be adjusted to the position that is the most comfortable for you. To adjust the handlebar, first turn the indicated handle counterclockwise to loosen it. Note: The adjustment handle works like a spanner. Turn the handle counterclockwise, pull it away from the handlebar, turn it clockwise, push it toward the handlebar, and then turn it counterclockwise again. Repeat this procedure until the handlebar is loose. Move the handlebar up or down to the desired position, and then turn the handle clockwise until it is tight.

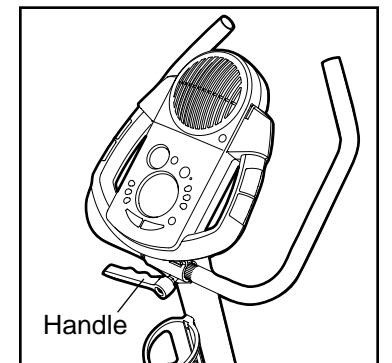

HOW TO LEVEL THE EXERCISE CYCLE

If the exercise cycle does not sit flat on the floor, turn one or both of the leveling pads until the exercise cycle is level.

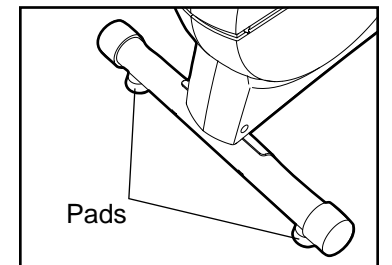

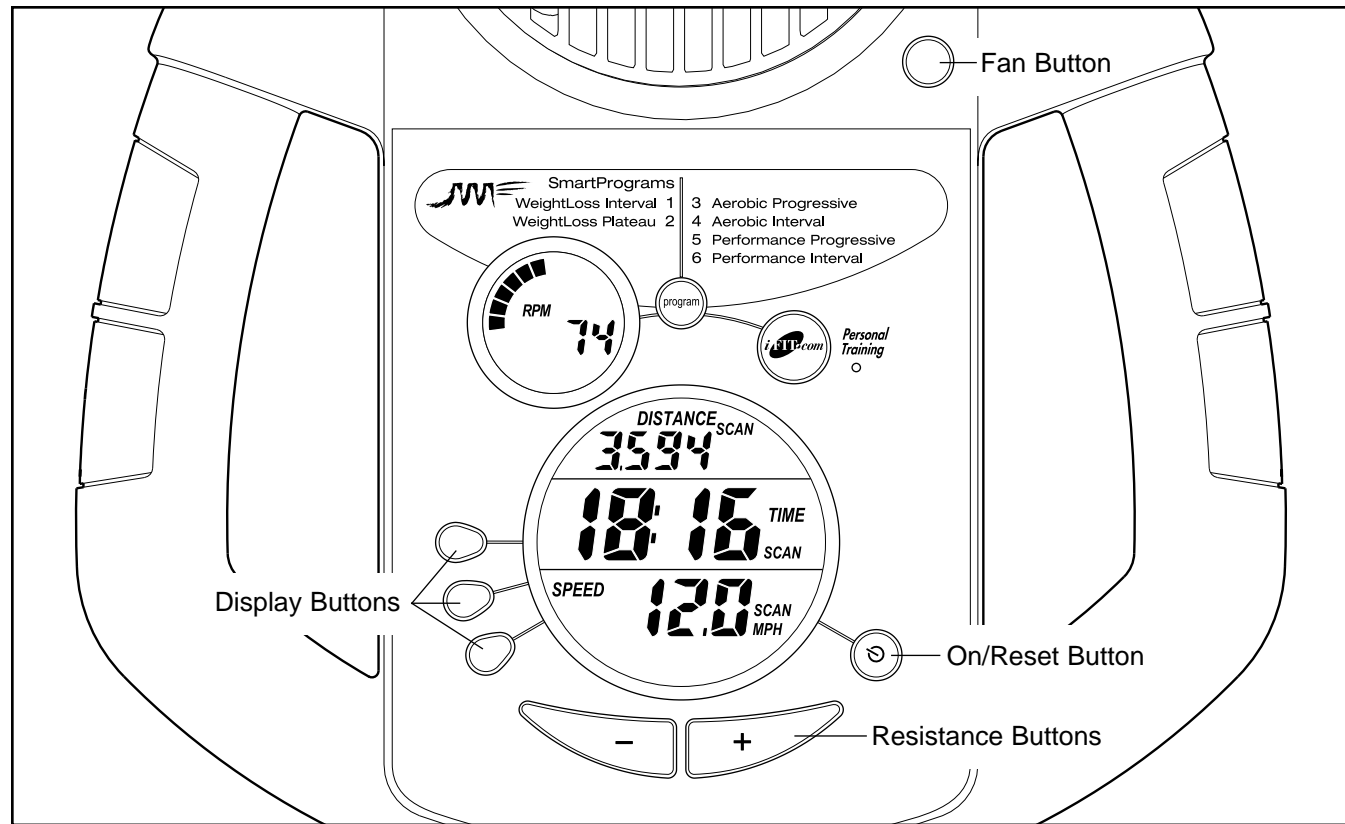

FEATURES OF THE CONSOLE

The advanced console offers a selection of features designed to make your workouts more enjoyable and effective. When the manual mode of the console is selected, the resistance of the pedals can be changed with the touch of a button. As you pedal, the console will provide continuous exercise feedback. You can even measure your heart rate using the built-in hand-grip pulse sensor.

In addition, the console offers six Smart programs. Each program automatically changes the resistance of the pedals and prompts you to increase or decrease your pace as it guides you through an effective workout.

The console also features iFIT.com interactive technology. Having iFIT.com interactive technology is like having a personal trainer in your home. Using the included audio cable, you can connect the exercise cycle to your home stereo, portable stereo, computer, or VCR and

play special iFIT.com CD and video programs (iFIT.com CDs and videocassettes are available separately). iFIT.com CD and video programs automatically control the resistance of the pedals and prompt you to vary your pace as a personal trainer coaches you through every step of your workout. High-energy music provides added motivation. **To purchase iFIT.com CDs and videocassettes, visit our Web site at www.iFIT.com.**

With the exercise cycle connected to your computer, you can also go to our Web site at www.iFIT.com and access programs directly from the internet. **Explore www.iFIT.com for more information.**

To use the manual mode of the console, see page 11. **To use a Smart program,** see page 13. **To use an iFIT.com CD or videocassette,** see page 17. **To use a program directly from our Web site,** see page 18.

HOW TO CONNECT YOUR HOME STEREO

Note: If your stereo has an unused **LINE OUT** jack, see instruction A below. If the **LINE OUT** jack is being used, see instruction B.

- A. Plug one end of the audio cable into the jack beneath the console. Plug the other end of the audio cable into the adapter. Plug the adapter into the **LINE OUT** jack on your stereo.

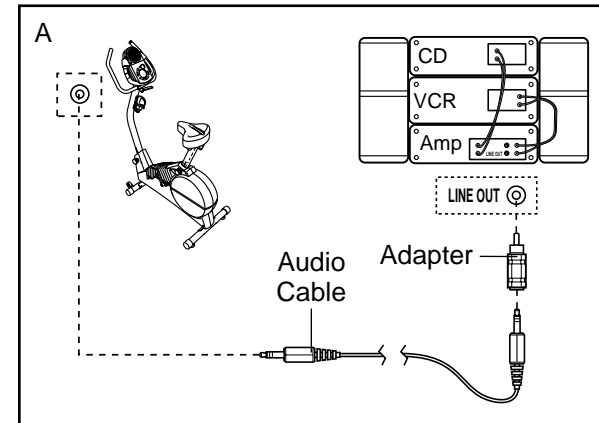

- B. Plug one end of the audio cable into the jack beneath the console. Plug the other end of the audio cable into the adapter. Plug the adapter into an **RCA Y-adaptor** (available at electronics stores). Next, remove the wire that is currently plugged into the **LINE OUT** jack on your stereo and plug the wire into the unused side of the Y-adaptor. Plug the Y-adaptor into the **LINE OUT** jack on your stereo.

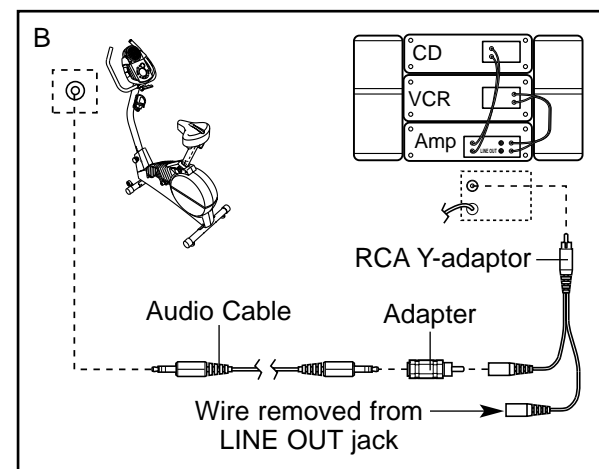

HOW TO CONNECT YOUR COMPUTER

Note: If your computer has a 3.5mm **LINE OUT** jack, see instruction A. If your computer has only a **PHONES** jack, see instruction B.

- A. Plug one end of the audio cable into the jack beneath the console. Plug the other end of the audio cable into the adapter. Plug the adapter into the **LINE OUT** jack on your computer.

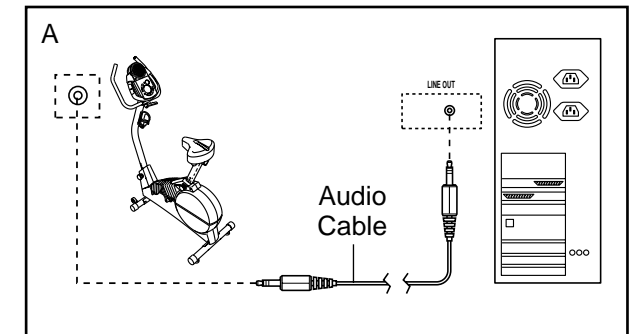

- B. Plug one end of the audio cable into the jack beneath the console. Plug the other end of the audio cable into the splitter. Plug the splitter into the **PHONES** jack on your computer. Plug your headphones or speakers into the other side of the splitter.

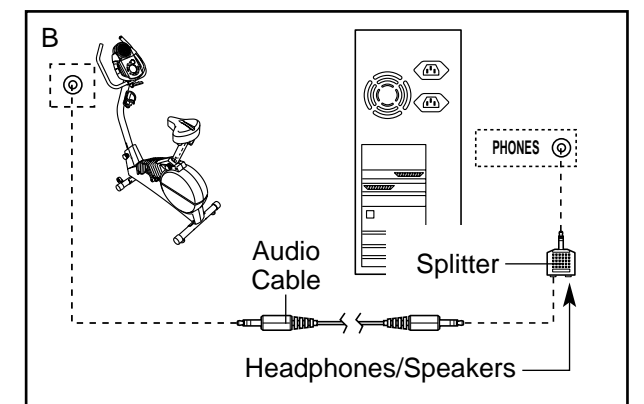

HOW TO CONNECT YOUR CD PLAYER, VCR, OR COMPUTER

To use iFIT.com CDs, the exercise cycle must be connected to your portable CD player, portable stereo, home stereo, or computer with CD player. See pages 14 and 15 for connecting instructions. To use iFIT.com video-cassettes, the exercise cycle must be connected to your VCR. See page 16 for connecting instructions. To use iFIT.com programs directly from our Web site, the exercise cycle must be connected to your computer. See page 15.

HOW TO CONNECT YOUR PORTABLE CD PLAYER

Note: If your CD player has separate LINE OUT and PHONES jacks, see instruction A below. If your CD player has only one jack, see instruction B.

A. Plug one end of the audio cable into the jack beneath the console. Plug the other end of the audio cable into the LINE OUT jack on your CD player. Plug your headphones into the PHONES jack.

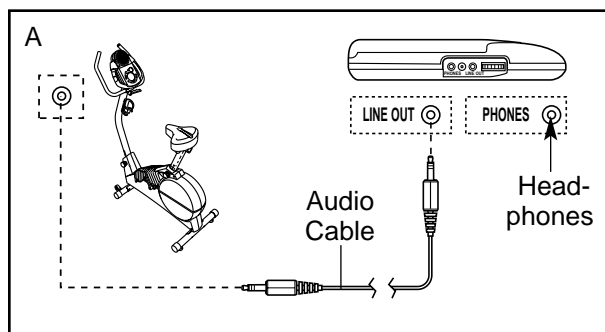

B. Plug one end of the audio cable into the jack beneath the console. Plug the other end of the audio cable into the splitter. Plug the splitter into the PHONES jack on your CD player. Plug your headphones into the other side of the splitter.

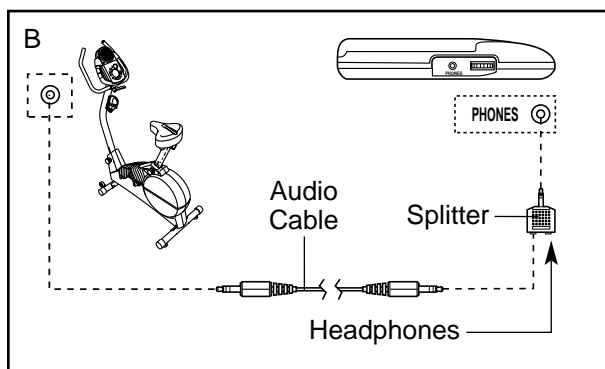

HOW TO CONNECT YOUR PORTABLE STEREO

Note: If your stereo has an RCA-type AUDIO OUT jack, see instruction A below. If your stereo has a 3.5mm LINE OUT jack, see instruction B. If your stereo has only a PHONES jack, see instruction C.

A. Plug one end of the audio cable into the jack beneath the console. Plug the other end of the audio cable into the adapter. Plug the adapter into an AUDIO OUT jack on your stereo.

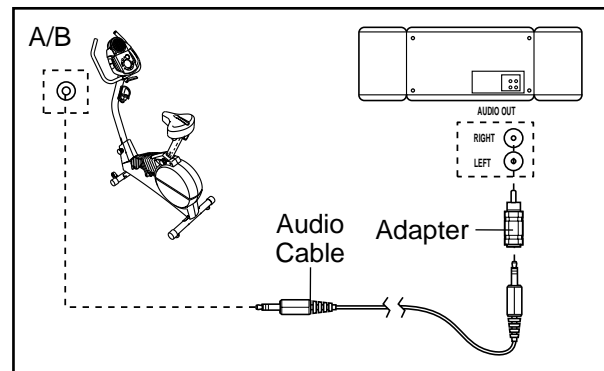

B. See the drawing above. Plug one end of the audio cable into the jack beneath the console. Plug the other end of the audio cable into the LINE OUT jack on your stereo. Do not use the adaptor.

C. Plug one end of the audio cable into the jack beneath the console. Plug the other end of the audio cable into the splitter. Plug the splitter into the PHONES jack on your stereo. Plug your headphones into the other side of the splitter.

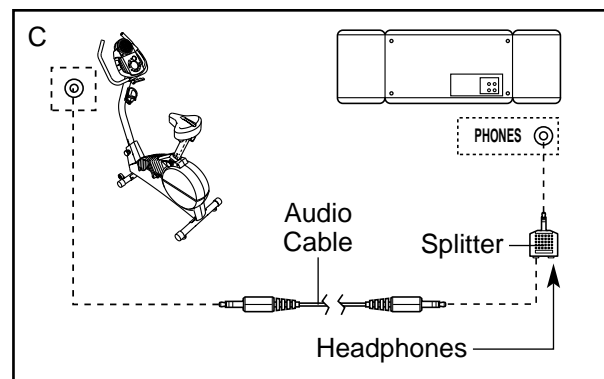

HOW TO USE THE MANUAL MODE

1 Turn on the console.

Note: The console requires four 1.5V "D" batteries (see assembly step 4 on page 6).

To turn on the console, press the On/Reset button or begin pedaling. (See the drawing on page 10 to identify the On/Reset button.)

2 Select the manual mode.

Each time the console is turned on, the manual mode will be selected. If a program has been selected, select the manual mode by pressing the Program button repeatedly until the letters RPM appear in the small display.

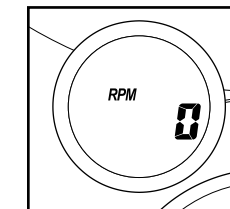

3 Begin pedaling and change the resistance of the pedals as desired.

As you pedal, change the resistance of the pedals by pressing the + and - buttons below the large display. There are ten resistance levels—level 10 is the most challenging. Note: After the buttons are pressed, it will take a few seconds for the resistance to reach the selected setting.

4 Follow your progress with the small display and the large display.

The small display will show your pedaling pace, in revolutions per minute (RPM). The indicator bar in the small display will increase or decrease in length as you increase or decrease your pedaling pace.

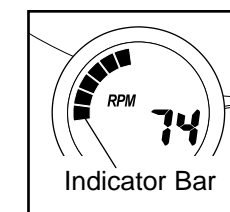

The upper section of the large display will show the distance you have pedaled

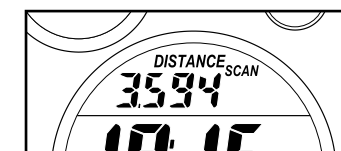

and the numbers of calories and fat calories you have burned (see FAT BURNING on page 20 for an explanation of fat calories). The display will change from one number to the next every few

seconds. If you use the handgrip pulse sensor, the display will also show your heart rate (see step 5 on page 12).

To view only the distance you have pedaled or the number of calories or fat calories you have burned, press the upper button on the left side of the large display until only the word DISTANCE, CALORIES, or FAT CALORIES appears in the upper section of the large display; make sure that the word SCAN does not appear. To again view the distance you have pedaled and the numbers of calories and fat calories you have burned, press the upper button until the word SCAN reappears.

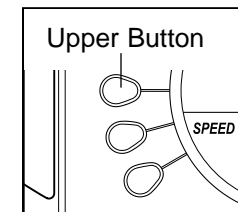

The centre of the large display will show the elapsed time and your current pace (pace is shown in minutes per mile in this section of the large display). The display will change from one number to the other every few seconds. Note: When a program is selected, the display will show the time remaining in the program instead of the elapsed time.



To view only the elapsed time or your pace, press the centre button on the left side of the large display until only the word TIME or PACE appears; make sure that the word SCAN does not appear. To again view both the elapsed time and your pace, press the centre button until the word SCAN reappears.

The lower section of the large display will show your pedaling speed and the resistance level.



The display will change from one number to the other every few seconds.

To view only your pedaling speed or the resistance level, press the lower button on the left side of the large display until only the word SPEED or RESISTANCE appears; make sure that the word SCAN does not appear. To again view both your pedaling speed and the resistance level, press the lower button until the word SCAN reappears.

To reset the displays, press the On/Reset button.

Note: The console can show speed and distance in either miles or kilometers. The letters MPH or KM/H will appear in the lower section of the large display to show which system of measurement is selected. To change the system of measurement, hold down the On/Reset button for about six seconds. Note: When the button is held down, the fan will turn on for a moment. When the batteries are replaced, it may be necessary to reselect the desired system of measurement.

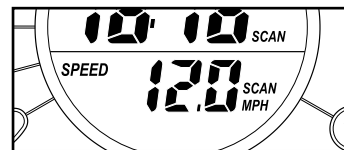

5 Measure your heart rate if desired.

If there are thin sheets of plastic on the metal contacts on the handgrips, peel off the plastic. To use the handgrip pulse sensor, hold the handgrips with your palms resting against the metal contacts. **Avoid moving your hands.** When your pulse is detected, the heart-shaped indicator in the large display will flash each time your heart beats. After a moment, two dashes (--) will appear and then your heart rate will be shown.

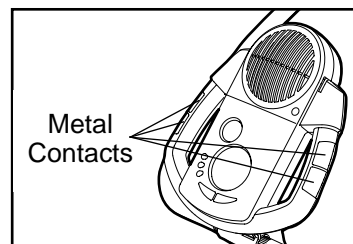

For the most accurate heart rate reading, continue to hold the handgrips for about 30 seconds. Note: When you first hold the handgrips, the large display will show your heart rate continuously for 30 seconds. The display will then show your heart rate along with other feedback modes.

6 Turn on the fan if desired.

To turn on the fan at low speed, press the fan button. To turn on the fan at high speed, press the fan button a second time. To turn off the fan, press the fan button a third time. Note: If the fan is turned on and the pedals are not moved for about half a minute, the fan will turn off to conserve the batteries.

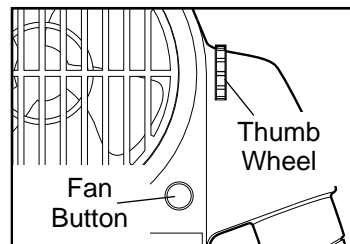

Rotate the thumb wheel on the right side of the console to pivot the fan to the desired angle.

7 When you are finished exercising, the console will automatically turn off.

If the pedals are not moved for a few seconds, the displays will pause and the time will flash in the large display.

If the pedals are not moved and the console buttons are not pressed for a few minutes, the console will turn off to conserve the batteries.

HOW TO USE A SMART PROGRAM

Each Smart program will automatically change the resistance of the pedals and prompt you to increase or decrease your pace as it guides you through an effective workout. Programs 1 and 2 are weight loss programs, programs 3 and 4 are aerobic programs, and programs 5 and 6 are high-performance programs.

Follow the steps below to use a Smart program.

1 Turn on the console.

See step 1 on page 11.

2 Select one of the Smart programs.

Each time the console is turned on, the manual mode will be selected. To select a Smart program, press the Program button repeatedly until the number 1, 2, 3, 4, 5, or 6 appears in the small display.

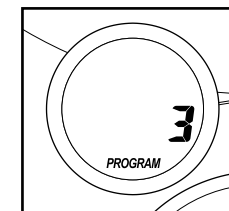

3 Begin pedaling to start the program.

To start the program, simply begin pedaling. Each Smart program consists of 20 or 30 one-minute periods. One resistance level and one target pace are programmed for each period. (The same resistance level and/or target pace may be programmed for two or more consecutive periods.)

At the end of each period of the program, the resistance of the pedals will automatically change if a different resistance level is programmed for the next period. Note: If the resistance level is too high or too low, you can change it by pressing the + and - buttons below the large display. However, when the current period is completed, the resistance of the pedals will automatically change if a different resistance level is programmed for the next period.

The target pace for the current period will be shown by the arrows in the small display. To pedal at the target pace, simply increase or decrease your pace until one segment of the indicator bar appears at the tip of each arrow (see the drawing above). At the end of each period, the number of arrows will change if a different target pace is programmed for the next period. When the number of arrows changes, change your pace until there is again one segment of the indicator bar at the tip of each arrow. **Important: The target pace is intended only to provide a goal. Your actual pace may be slower than the target pace, especially during the first few months of your exercise program. Make sure to pedal at a pace that is comfortable for you.**

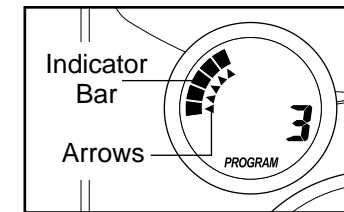

During the program, the centre of the large display will show the time remaining in the program. If you stop pedaling for a few seconds, the displays will pause and the time will flash. If you continue pedaling after the program is completed, the displays will continue to show exercise feedback.

4 Follow your progress with the large display.

See step 4 on page 11.

5 Measure your heart rate if desired.

See step 5 on page 12.

6 Turn on the fan if desired.

See step 6 on page 12.

7 When you are finished exercising, the console will automatically turn off.

See step 7 on page 12.