

Secondary Distribution Switchgear

# Fluokit M24+

Air insulated switchgear

Instructions  
Civil Engineering Structures





<b>1</b>	<b>Schneider Electric at your service</b>	<b>1</b>
1.1	Particular instructions for operations and interventions	1
1.2	Protection equipments	1
1.3	Symbols of information	1
1.4	Symbols and important safety informations	1
1.5	Contacts	1
<b>2</b>	<b>With regards to this User Manual</b>	<b>2</b>
2.1	Use of this User Manual	2
2.2	Definition of the substations	2
2.3	Access to the substation	2
2.4	Other technical notices to be consulted	2
<b>3</b>	<b>Dimensions of the Functional Units</b>	<b>3</b>
3.1	Dimensions and approximate weight of the Functional Units	3
3.2	Dimensions of an IS - PF - PFA or TM Functional Unit	4
3.3	Dimensions of a PGB or PGC Functional Unit	4
<b>4</b>	<b>General rules for the installation of Functional Units</b>	<b>5</b>
4.1	Reminder concerning normal installation and service conditions (in accordance with IEC 62271-1)	5
	* Permissible ambient temperature	5
	* Installation altitude	5
	* Atmospheric pollution	5
	* Permissible atmospheric humidity level	5
4.2	Substation installation requirements	5
4.3	Installation of the switchboard	5
4.4	Precautions for the installation of a Fluokit M24+ switchboard	5
<b>5</b>	<b>Installing Functional Units</b>	<b>6</b>
5.1	Example of a free installation switchboard, without internal arc withstand	6
5.2	Switchboard back-to-back against a wall or not, with internal arc withstand	7
5.3	Examples of the installation of Functional Units with internal arc deflectors	8
5.4	Reserve opening for connecting the earthing cable	10
5.5	Installing the Functional Units to the floor	10
5.6	Geometry of the cable trough	13
5.7	Altitude of the connecting points in relation to the cable flanges (other than mounting base)	14
<b>6</b>	<b>The civil engineering structure</b>	<b>15</b>
6.1	Geometry	15
6.2	Special cases	15
<b>7</b>	<b>Civil Engineering without a metal section</b>	<b>16</b>
7.1	Example of the installation of a switchboard in a conventional building	16
7.2	Work on the Civil Engineering structure	16
7.3	Advice that is appropriate for the various types of cable troughs	16
7.4	Layout on a type 2 cable trough, with width of more than 50cm	16
<b>8</b>	<b>Civil Engineering structure with open metal sections</b>	<b>17</b>
8.1	Mounting on metal sections called 'irons'	17
8.2	Work on the Civil Engineering structure	17
	Preparation of the sections	17
	Levelling the profile sections	17
	Reserve opening at the extremity of each rail	18
	Pouring the cement top coat	18
	Case of a type 2 cable trough	18
<b>9</b>	<b>Civil Engineering structure with metal sections on a slab</b>	<b>19</b>
9.1	Mounting of metal profile sections on slabs	19
9.2	Preparation of the frame in profile sections	19
9.3	Installation of the frame	19
9.4	Pouring the cement top coat	20
9.5	Installation of the switchboard at height, on a frame	20
<b>10</b>	<b>Connecting the switchboard to earth</b>	<b>21</b>
10.1	Reserve opening for connecting the earthing circuit	21

---

<b>11</b>	<b>Last checks before installation of the Functional Units</b>	<b>22</b>
11.1	Reading of the surface evenness .....	22
11.2	Layout of the Functional Units .....	22
<b>12</b>	<b>Notes .....</b>	<b>23</b>

# 1 Schneider Electric at your service

© - Schneider Electric - 2011. Schneider Electric, the Schneider Electric logo and their figurative forms are Schneider Electric registered trademarks. The other brand names mentioned within this document, whether they be copyright or not, belong to their respective holders.

Schneider Electric request the carefully reading of the following instructions in order to familiarize yourself with the product in this document before trying to install, operation, put into service or conduct the maintenance on it.

Our products are fully quality controlled and tested at the factory in accordance with the standards and regulations currently in force.

The correct functioning and lifespan of the product depend on respecting the installation, commissioning and exploitation instructions found in this manual. Not respecting these instructions is likely to invalidate any guarantee.

Local safety requirements which are in accordance with these instructions, especially those regarding the safety of product operators and other site workers, must be observed.

Schneider Electric declines any responsibility for the following points:

- the non respect of the recommendations in this manual which make reference to the international regulations in force.
- the non respect of the instructions by the suppliers of cables and connection accessories during installation and fitting operations,
- possible aggressive climatic conditions (humidity, pollution, etc.) acting in the immediate environment of the materials that are neither suitably adapted nor protected for these effects.

## 1.1 Particular instructions for operations and interventions

This user manual does not list the locking-out procedures that must be applied. The interventions described are carried out on de-energized equipment (in the course of being installed) or locked out (non operational).

Whilst commissioning and operating the product all general safety instructions for electrical applications (protective gloves, insulating stool, etc.) must be respected, this in addition to the standard operating instructions.

All operations must be completed once started.

The durations (for completing the operations mentioned) given in the maintenance tables are purely an indication and depend on on-site conditions.

## 1.2 Protection equipments

Only qualified and accredited people can operate on our products. They must be equipped with all the correct protective equipment required for the task being performed.

A qualified person is one who has the skills and knowledge related to the construction, installation and operation of electrical equipment and has received safety training to recognize and avoid the hazards involved.

Except when it is imposed, the wearing of the gloves has been voluntarily limited in this manual so as to have clear visuals of the hands and operations described.

## 1.3 Symbols of information

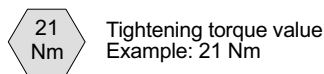
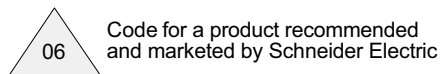

## 1.4 Symbols and important safety informations

The following special messages may appear throughout this bulletin or on the equipment to warn of potential hazards or to call attention to information that clarifies or simplifies a procedure.



**DANGER** indicates an imminently hazardous situation which, if not avoided, **will result in** death or serious injury.



**WARNING** indicates a potentially hazardous situation which, if not avoided, **can result in** death or serious injury.



**CAUTION** indicates a potentially hazardous situation which, if not avoided, **can result in** minor or moderate injury.



**NOTICE** is used to address practices not related to physical injury. The safety alert symbol shall not be used with this signal word.

## 1.5 Contacts

Group Schneider Electric service centers are there for:

- Engineering and technical assistance
- Commissioning
- Training
- Preventive and corrective maintenance
- Spare parts
- Adaptation work

**Schneider Electric Energy France**

35 rue Joseph Monier - CS 30323

F-92506 Rueil-Malmaison Cedex

[www.schneider-electric.com](http://www.schneider-electric.com)

### 2.1 Use of this User Manual

This User Manual describes the works or arrangements necessary for the installation of a HVA switchboard of the Fluokit M24+ type.

In the cases of replacement of the Fluokit M24 switchboard or substation renovation, a specific design study must be carried out.

### 2.2 Definition of the substations

Amongst substations that are prefabricated or built outdoors, walk-in substations can reach, or even exceed 2.5 m in height. They allow operating personnel to penetrate into the substation and work in them sheltered from bad weather.

The indoor substations with "prefabricated metal-clad bays" are installed in areas that the User reserves in one of the buildings in the factory, or in a building specially built for this purpose in the case of transformer substations for HVA distribution networks.

### 2.3 Access to the substation

Substation access must remain free at all times and under any circumstances. It is therefore generally installed on the side of the road.

Passages must be designed to permit easy maintenance for all of the substation's elements (circuit breaker, transformer, etc.)

### 2.4 Other technical notices to be consulted

- AMTNoT090-02 Fluokit M24+ Installation - Commissioning - Operation - Maintenance

### 3 Dimensions of the Functional Units

#### 3.1 Dimensions and approximate weight of the Functional Units

Functional Units	IS - PFA		TM		PGB - PGC				PBB or PGC 1,250A
Width (mm)	375	500	375	500	750	875	1125	1250	1000
Overall Depth (mm)	1072	1072	1072	1072	1110*	1110*	1110*	1110*	1110
Height (mm) <small>standard with deflector or LV box on the roof</small>	1610	1610	1610	1610	1610	1610	1610	1610	1610
	1950	1950	1950	1950	1950	1950	1950	1950	1950
Manoeuvring space at the front (mm)	800	800	800	800	1000	1000	1000	1000	1000
Approximate weight (kg)	115	125	195	210	410	460	510	610	600

\* Withdrawable Functional Unit in size 1,120 mm



### 3.2 Dimensions of an IS - PF - PFA or TM Functional Unit

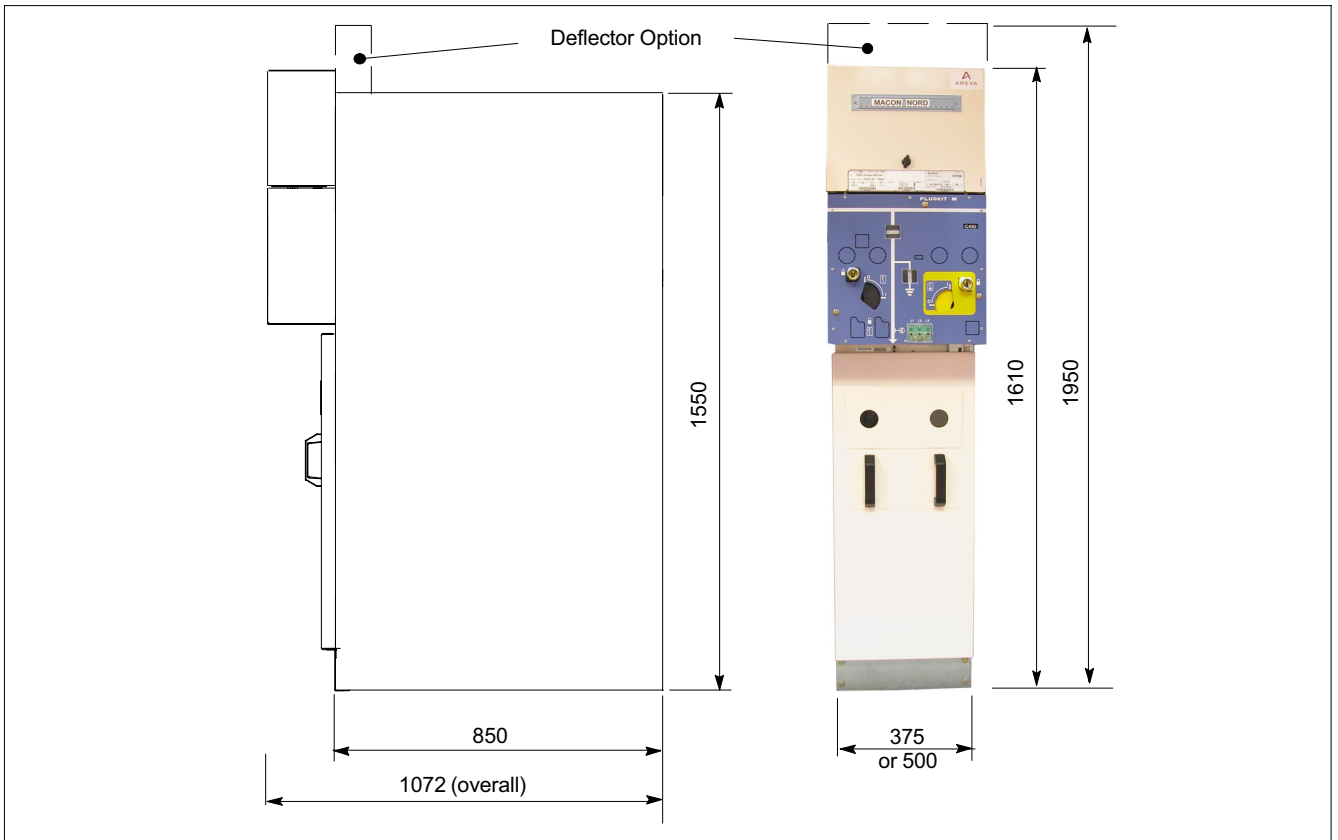

### 3.3 Dimensions of a PGB or PGC Functional Unit

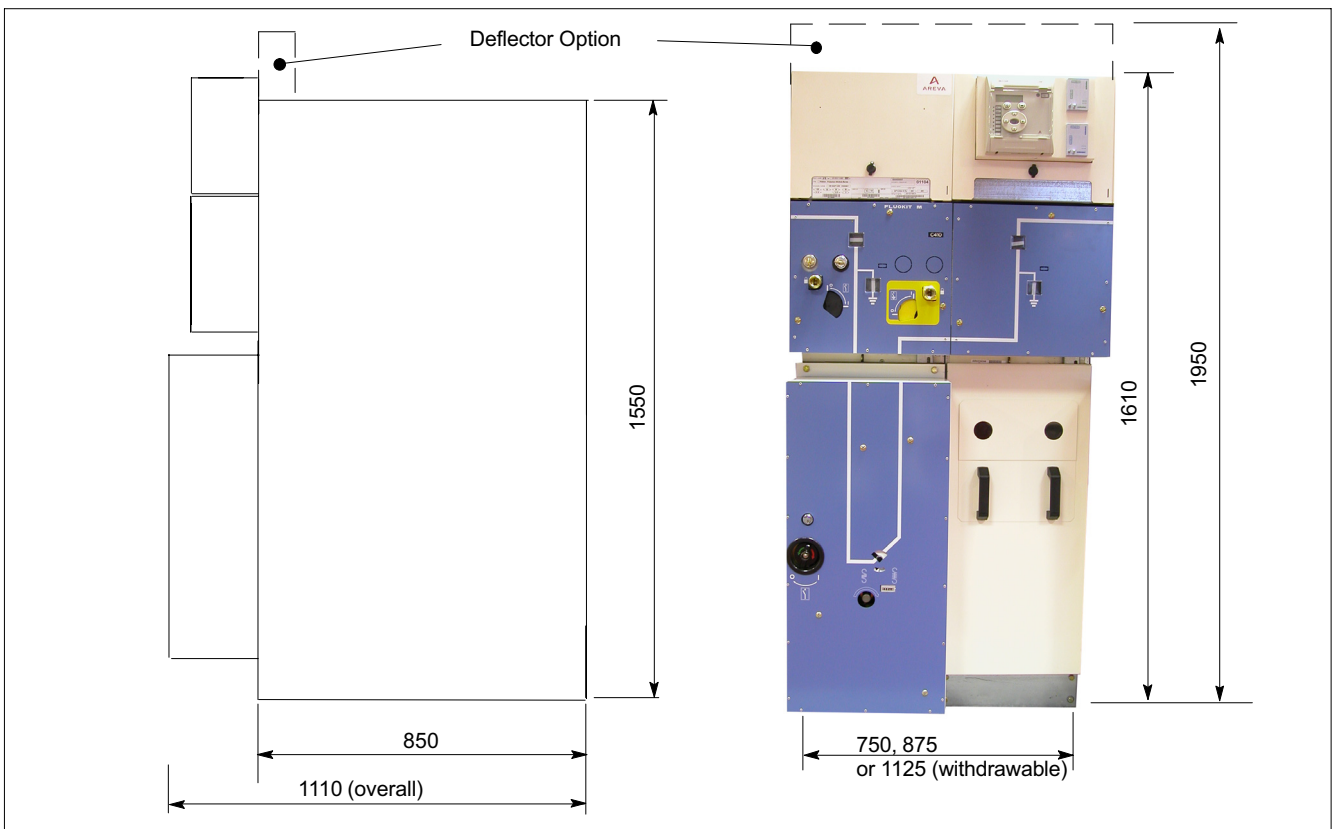



## 4.1 Reminder concerning normal installation and service conditions (in accordance with IEC 62271-1)

### \* Permissible ambient temperature

The ambient air temperature should be comprised between - 5°C and + 40° C.

The mean measured value for a 24 hour period must not exceed 35° C.

### \* Installation altitude

Items of HV equipment are defined in accordance with European Standards and can be used up to an altitude of 1,000 m.

Beyond this, account must be taken of the decrease in dielectric withstand.

For these specific cases, contact the Schneider Electric Sales Department.

### \* Atmospheric pollution

The ambient air must not contain any dust particles, fumes or smoke, corrosive or flammable gases, vapours or salts.

### \* Permissible atmospheric humidity level

The average atmospheric relative humidity level measured over a 24-hour period must not exceed 95%.

The average water vapour pressure over a period of 24 hours must not exceed 22 mbar.

The average atmospheric relative humidity value measured over a period of one month must not exceed 90 %.

The average water vapour pressure over a period of one month must not exceed 18 mbar.

Condensation may appear in case of any sharp variation in temperature, due to excessive ventilation, a high atmospheric humidity level or the presence of hot air. This condensation can be avoided by an appropriate lay-out of the room or of the building (suitably adapted ventilation, air driers, heating etc.).

Whenever the humidity level is higher than 90 %, we recommend that you take appropriate corrective measures. For any assistance or advice, contact the Schneider Electric After-Sales department.

## 4.2 Substation installation requirements

The substation must be sheltered from flooding and any infiltrations. No ducts of any kind must pass through the substation's immediate environment without special protection (sheaths or ducts).

Water, snow, or animal salts must not be able to penetrate.

Also prevent any penetration by small animals such as rodents, snakes, lizards, etc. especially in tropical areas.

The room must be equipped with standardised high level and low level ventilation.

## 4.3 Installation of the switchboard

The positioning of the Functional Units is primordial for:

- minimum spaces at the front (walk-in corridor for manoeuvring), at the rear and on each side of the switchboard. Certain passages must be sufficient for free movement and execution of operation and maintenance manoeuvres,
- leave the room's access door free,
- take all measures to prevent all incidence of climatic conditions (humidity, pollution, etc.).

The delimitation of the civil engineering layout depends on the type and quantity of materials to be installed refer to the following chapters).

## 4.4 Precautions for the installation of a Fluokit M24+ switchboard

This equipment is designed to be installed back-to-back against a wall. Nevertheless, if the room's architecture does not permit this type of installation, other options exist in order to meet the requirements of Standard IEC62271-200 FLR (rear access, internal arcing etc.)

Respect the imposed distances (see chapter 5).

Ensure that the envisaged layout does not disturb access to the room. It must be possible to enter or withdraw items of equipment without any handling difficulty.

Do not place Functional Units below any ventilation grilles, air vents, or air conditioning grilles or in the immediate proximity of glass tile panels in direct contact with the outside.

The switchboard must not be exposed to any solar radiation. A direct exposure can lead to excessive overheating of the low voltage racks.

Cable troughs and ducts must be blocked up to avoid:

- any draughts of air below the Functional Units,
- any rise in humidity or pollution coming from below ground.

## 5.1 Example of a free installation switchboard, without internal arc withstand

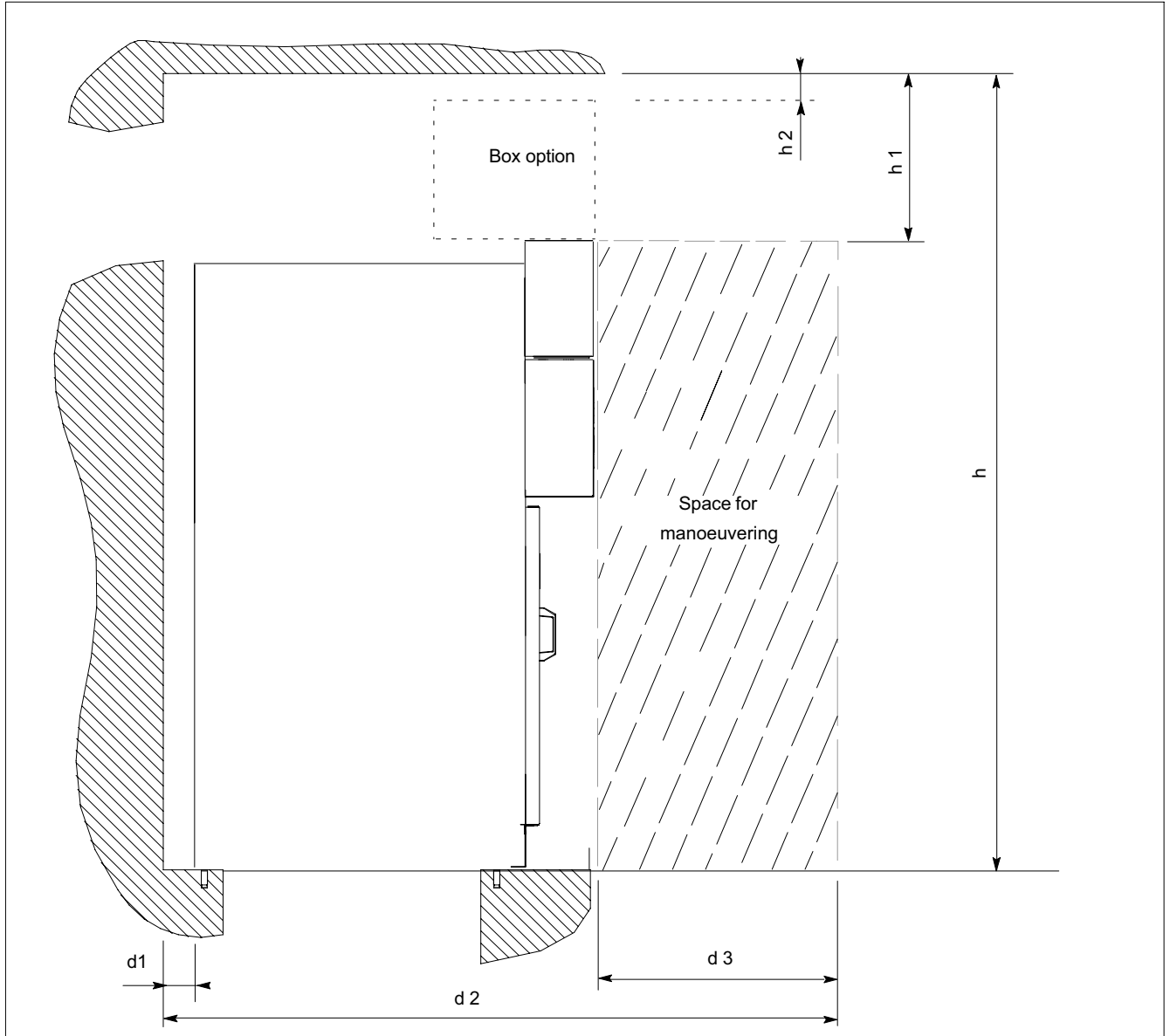

Distance	d1 (mm)	d 2 (mm)		d 3 (mm)		h (mm)	h1 (mm)	h2 (mm)
		IS-PFA-TM	PGB - PGC	IS-PFA-TM	PGB - PGC			
Normal	100	1972	2122	800	1000	2100	490	150
Recommended	250	2360		1000		2150	590	260

5.2 Switchboard back-to-back against a wall or not, with internal arc withstand

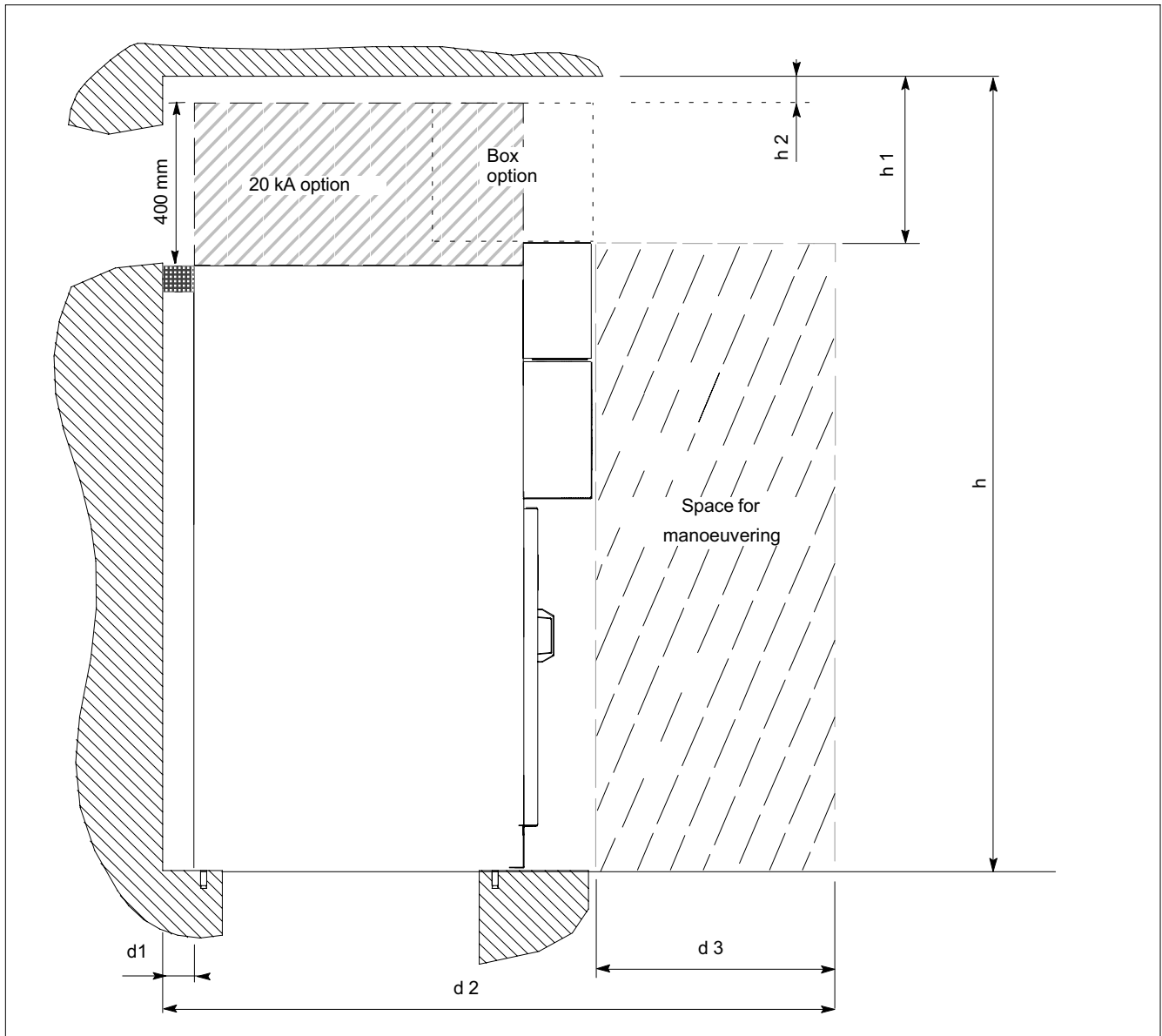

Distances	d1 (mm)	d 2 (mm)		d 3 (mm)		h (mm)	h1 (mm)	h2 (mm)
		IS-PFA-TM	PGB - PGC	IS-PFA-TM	PGB - PGC			
12.5 kA AF (0.7 s) (HN64S41)	100	1972	2210	800	1000	Min. 2100	490	150
16 kA AF or AFL (1 s)	100	1972	2210	800	1000	Min. 2150	540	200
20 kA AF or AFL (1 s)	250	2122	2360	800	1000	Min. 2150	540	200
12.5 kA or 16 kA AFLR (1 s)	Free	Free	Free	800	1000	Min. 2150	540	200
20 kA AFLR (1 s)	Free	Free	Free	800	1000	Min. 2150	540	200
25 kA AF (1 s)	250	2372	2610	800	1000	Min. 2150	540	200

### 5.3 Examples of the installation of Functional Units with internal arc deflectors

For all other cases, consult the Schneider ElectricSales Department.

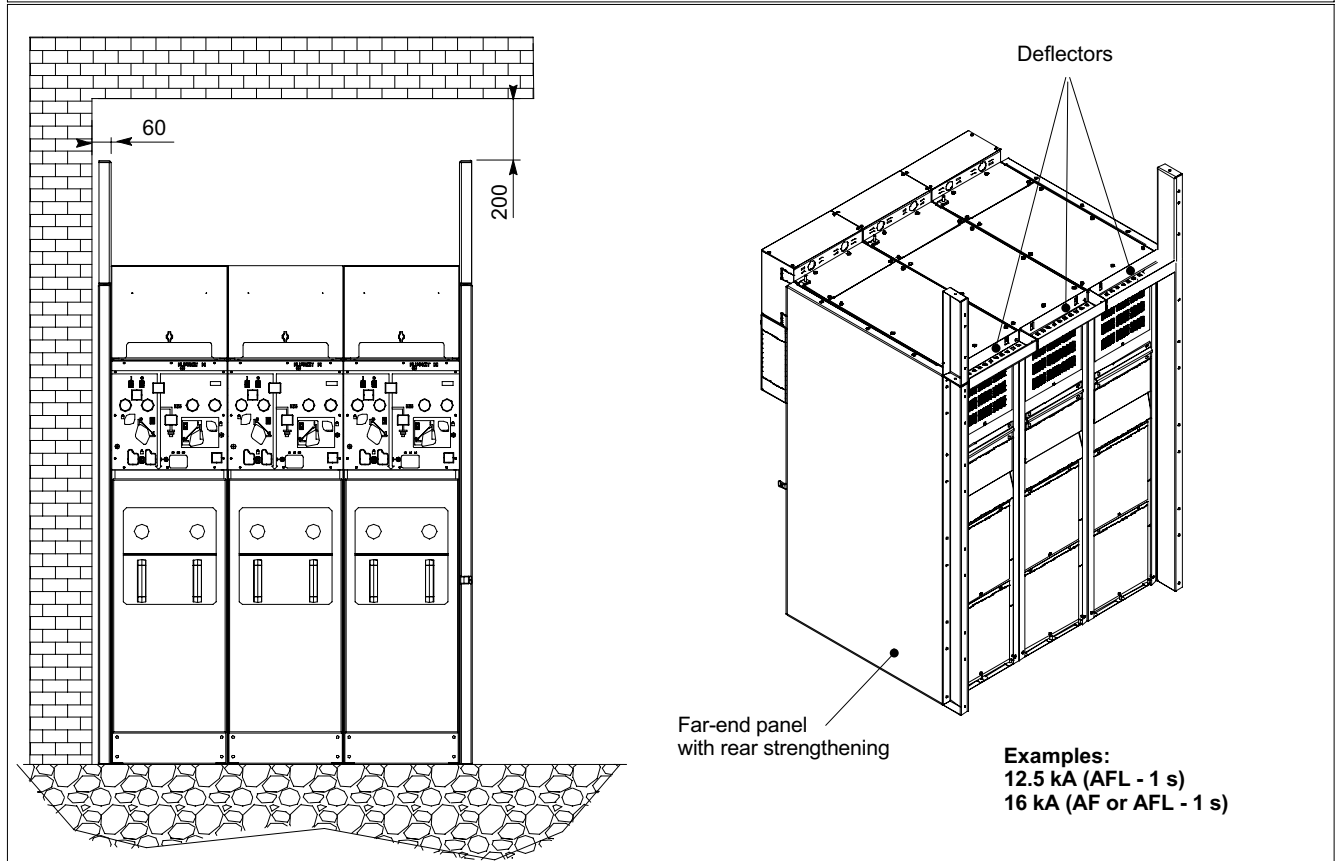
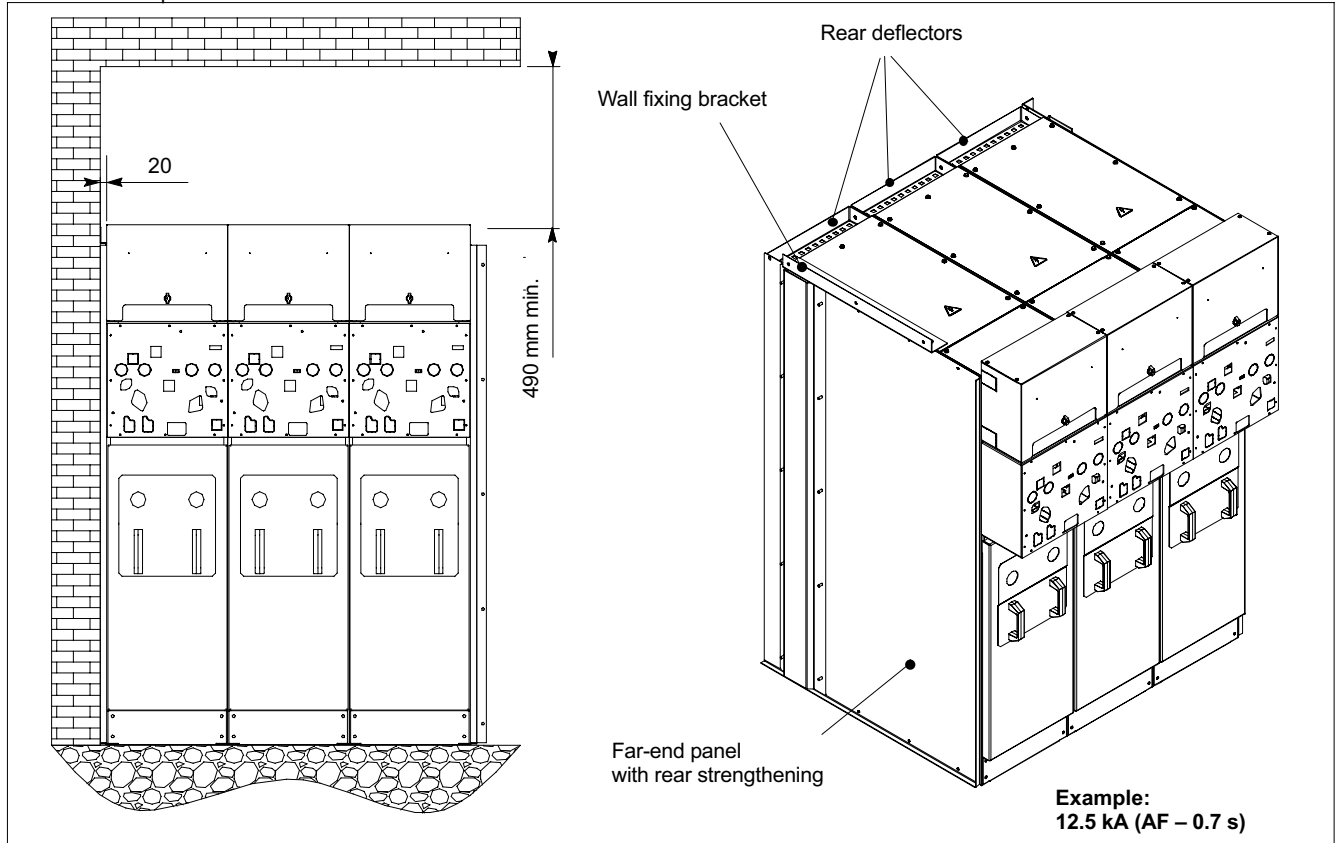

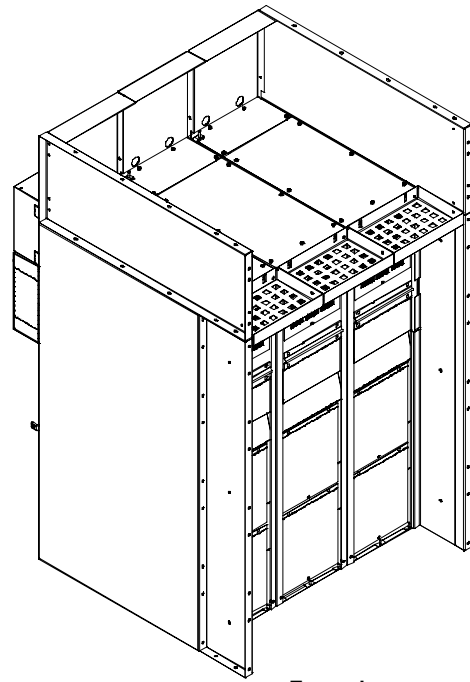
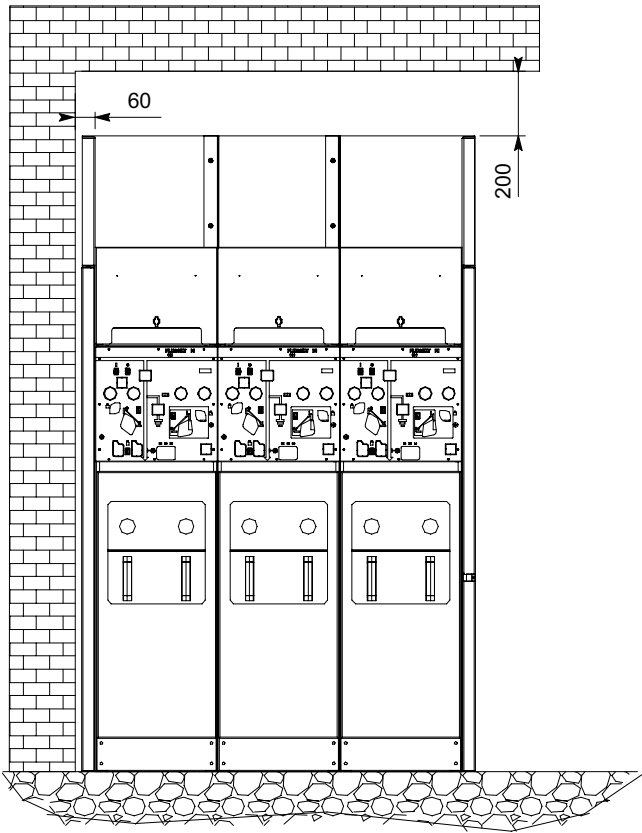

Example:  
20 kA (AF or AFL - 1 s)

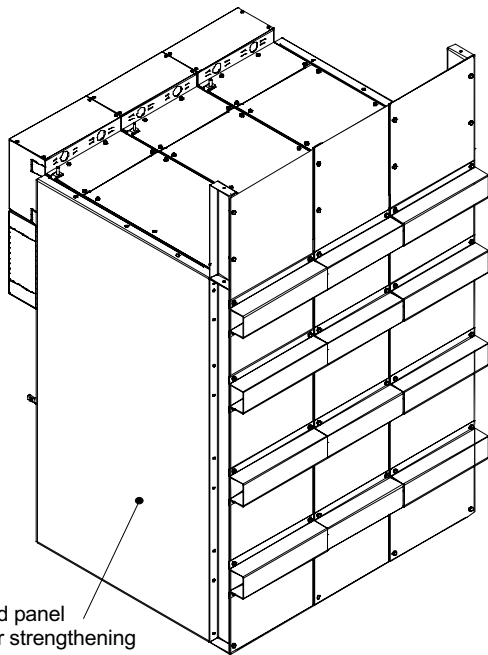

Far - end panel  
with rear strengthening

Example:  
12.5 and 16 kA (AFLR - 1 s)

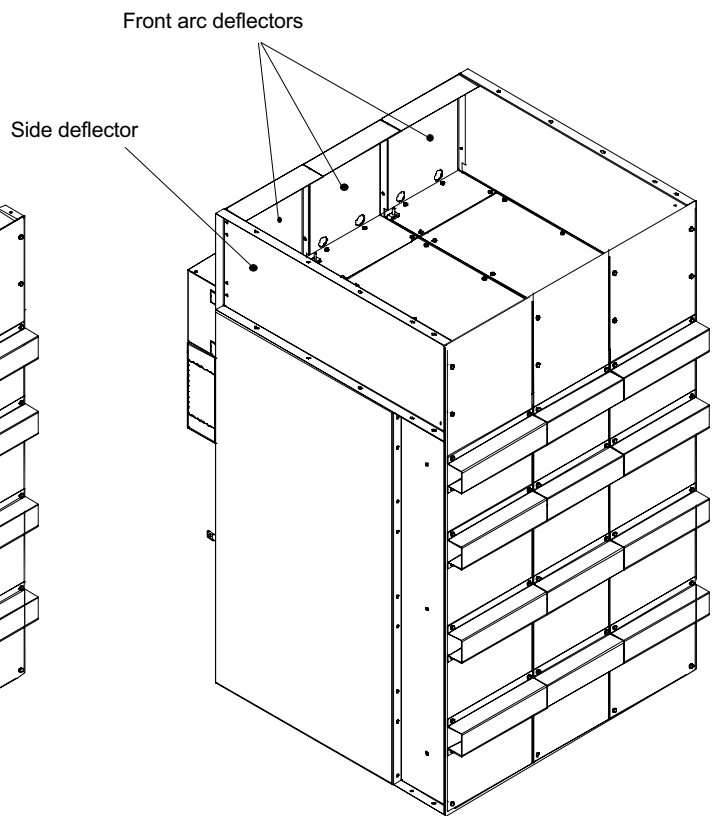

Example:  
20 kA (AFLR - 1 s)

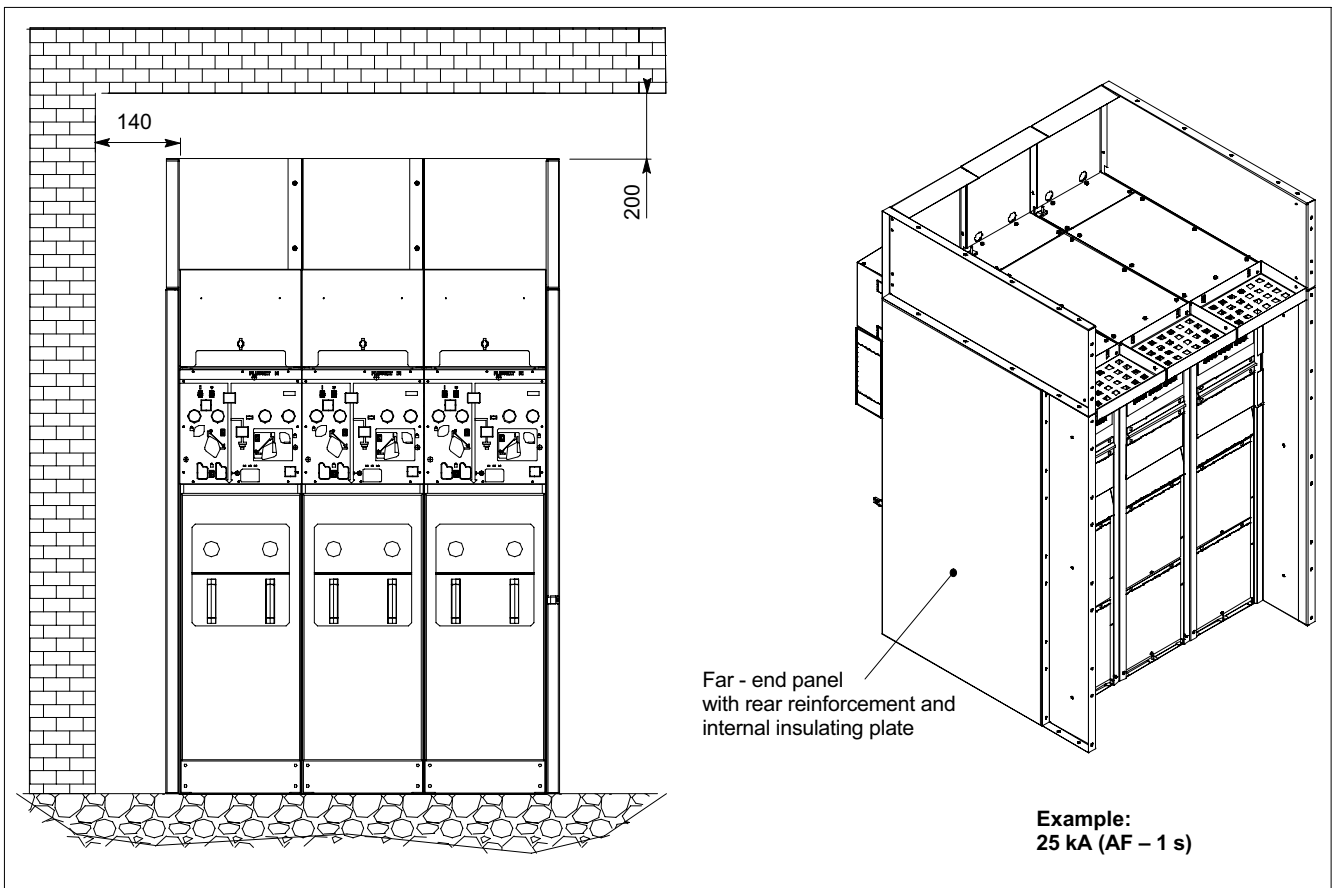

### 5.4 Reserve opening for connecting the earthing cable

See chapter 10.

### 5.5 Installing the Functional Units to the floor

The routes, seen from above, represent the perimeter of the Functional Unit bearing on the floor.

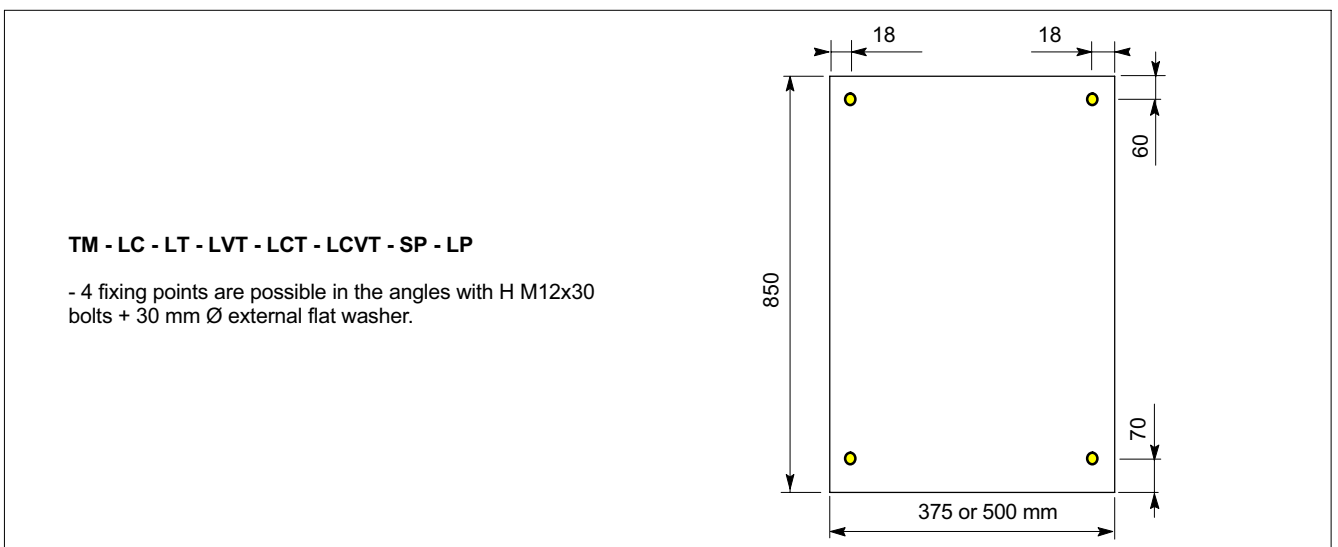

**IS - PF - PFA - LST - LD**

- 4 fixing points are possible in the angles with H M12x30 bolts + 30 mm Ø external flat washer.
- width of the cable trough variable depending on the depth of the Functional Unit

C (mm)	375	500
C1 (mm)	117.5	180

N.B.: 640 mm if installation using PGC

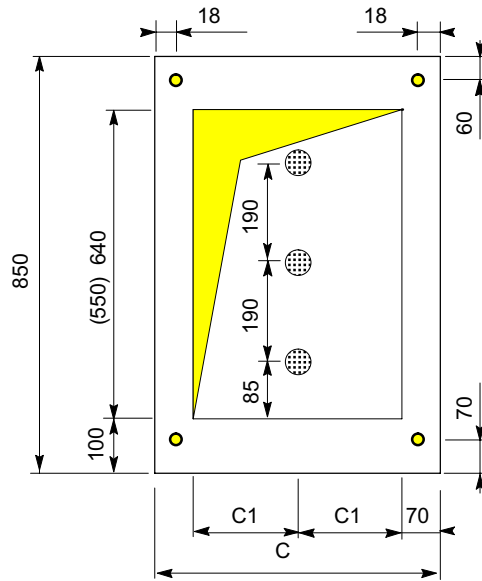

**IS with assembly of 3 current transformers**

C2 (mm)	195.5
C3 (mm)	164.5

N.B.: 640 mm if installation using PGC

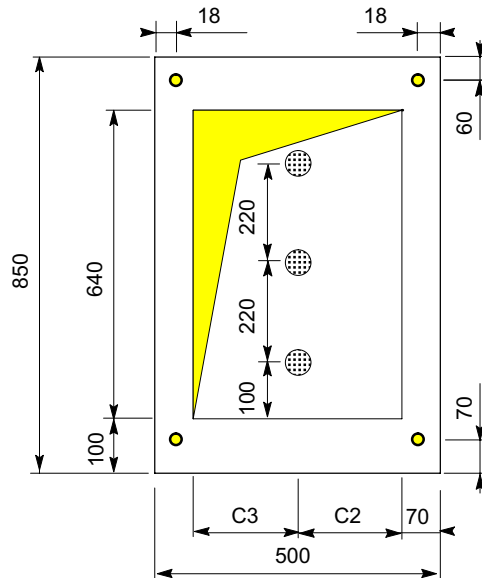

**PGB - PGc + LR**

C (mm)	750	875	1125
C2 (mm)	339	464	339

**PBB**

C (mm)	1000
C2 (mm)	464

- 4 fixing points possible in the right hand part, spaced out depending on the width of the Functional Unit.
- Fixing by H M12x30 bolts + 30 mm Ø external flat washer.
- The circuit breaker's axes are represented by dotted lines.

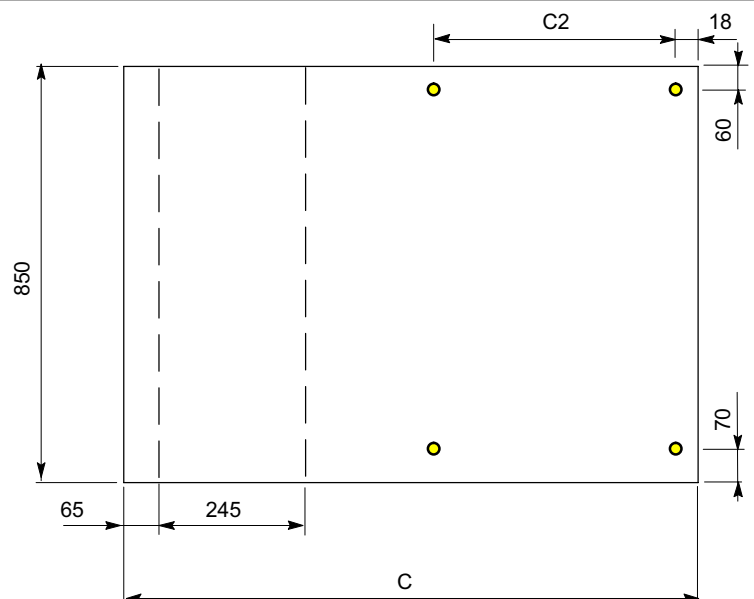

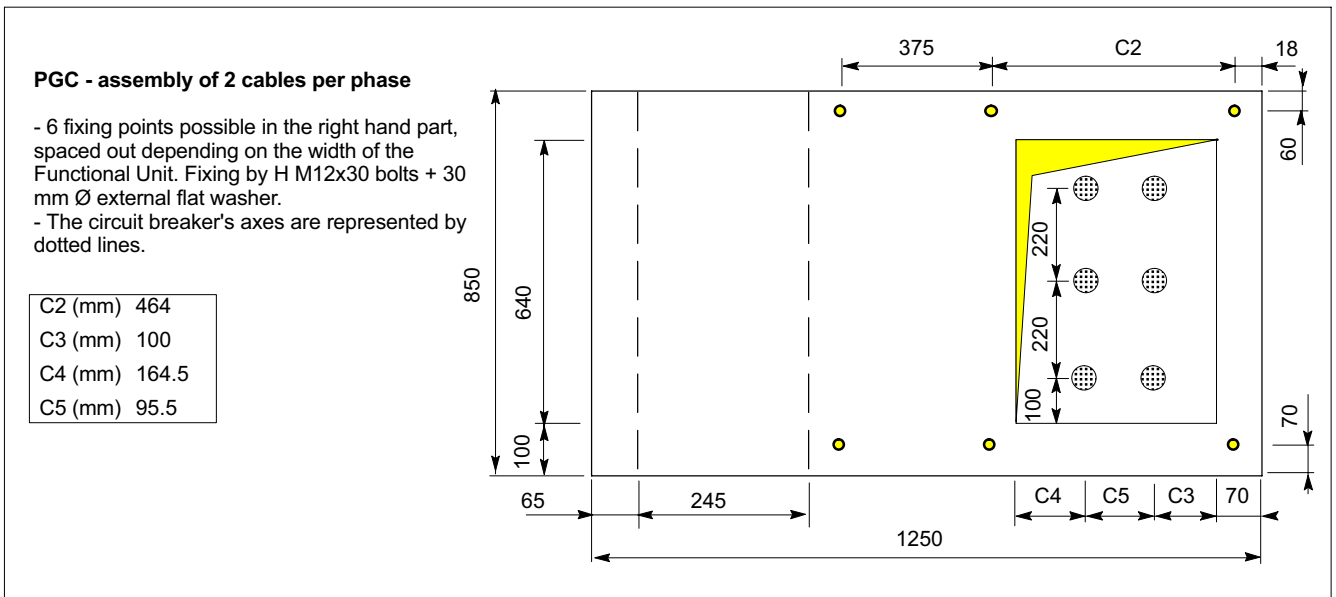
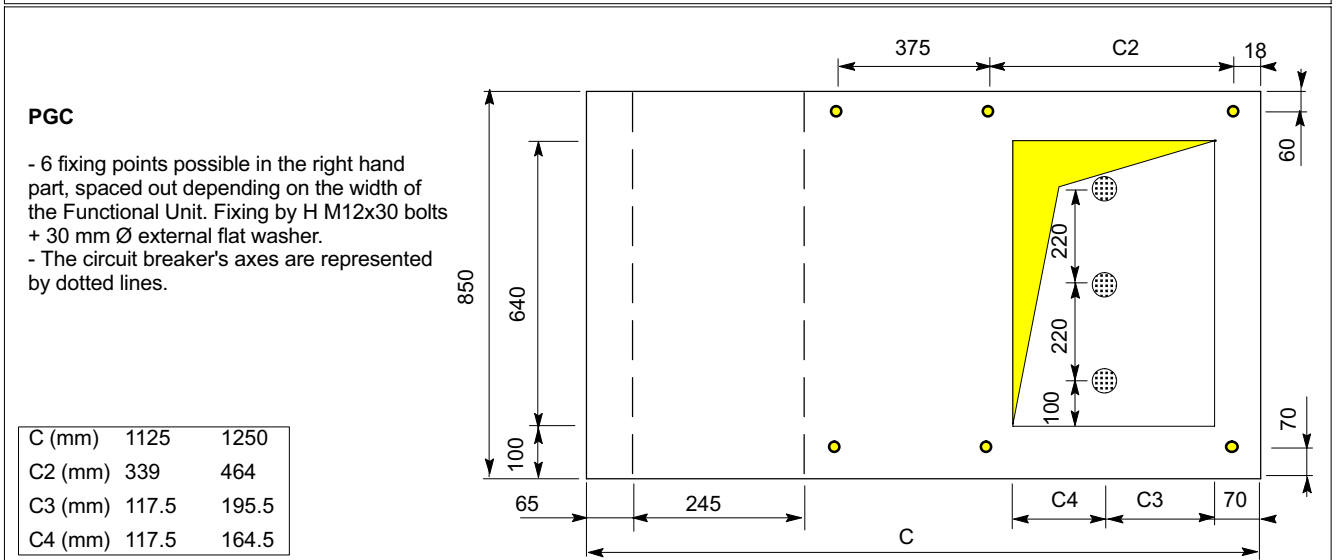
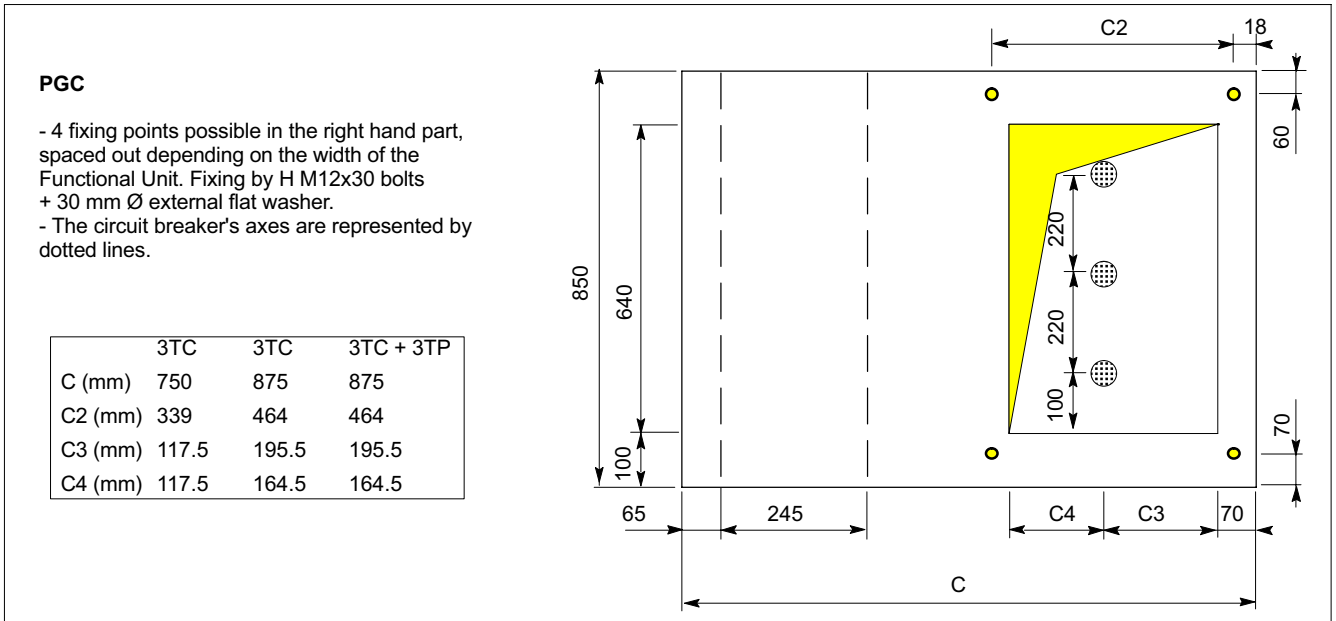



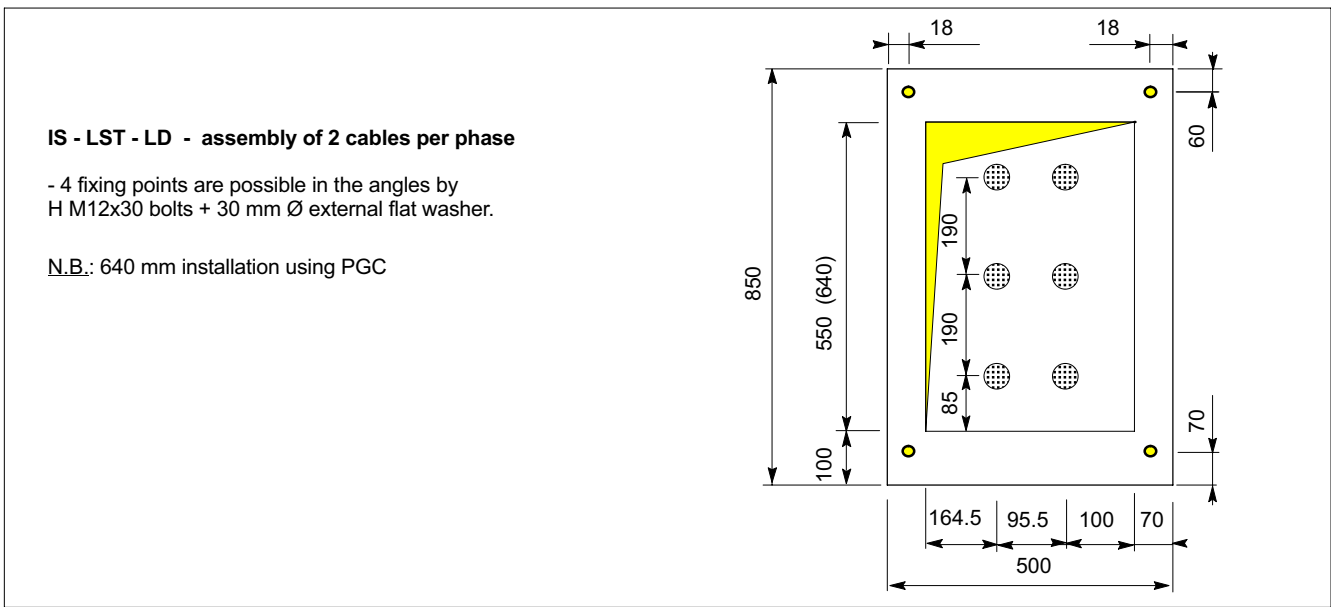

## 5.6 Geometry of the cable trough

The depth of the cable trough depends on the cross-section of the HV cables. Generally this depth [P] is equal to (generally higher) than the bend radius of the cables [R].

The length of the cable is calculated as a function of the altitude [A] of the connecting point.

**NOTICE**

Refer to the cable manufacturer's recommendations (ambient temperature, etc.).

Cable sections (mm <sup>2</sup> )	Depth for a single pole cable* P (mm)	Depth for a three-pole cable* P (mm)
50	450	600
95	450	700
150	600	800
240	600	900
300	600	-
400	600	-

\* depth except assembly of tank. In the case of assembly of tank, Depth = P + tank height.

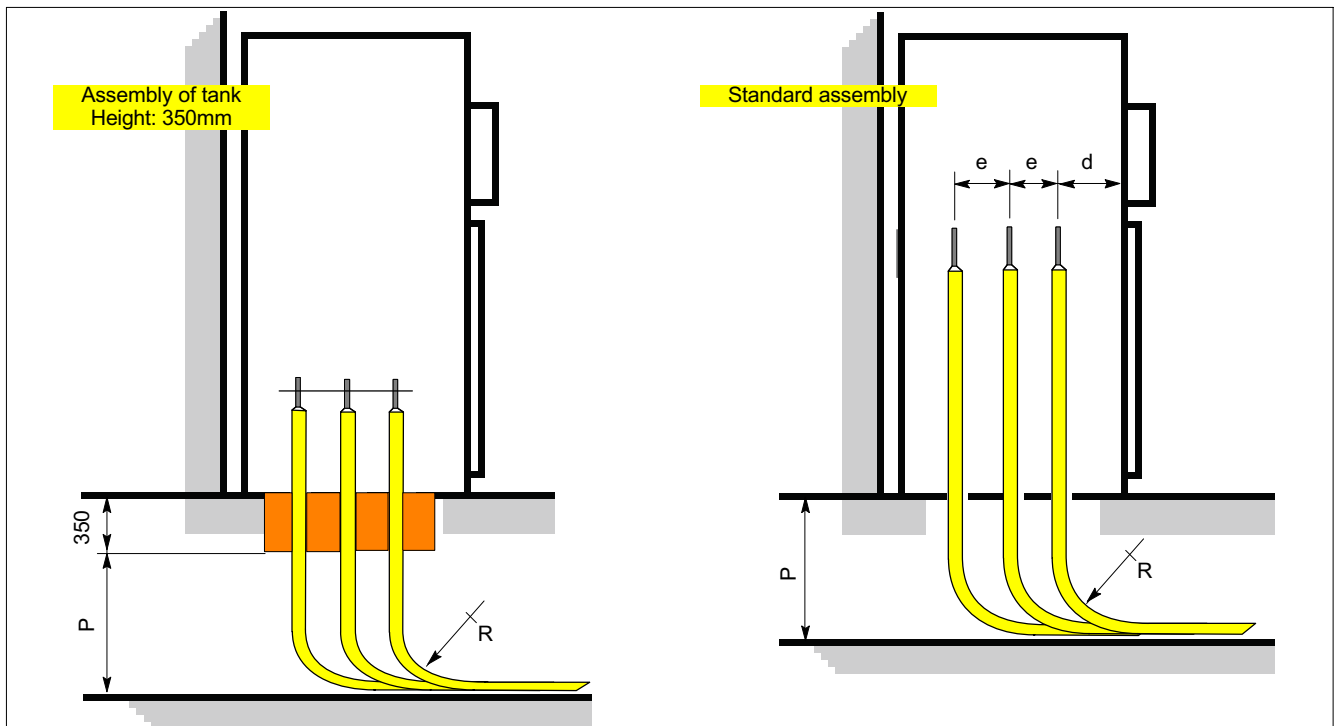

Functional Unit	Distance from the edge [d] (mm)	Distance between phases [e] (mm)
IS - LST	185	190
PF-PFA	185	190
PGC	200	220

**5.7 Altitude of the connecting points in relation to the cable flanges (other than mounting base)**

Functional Unit	A (mm)	A1 (mm)
IS - LST	646.5	908
PF-PFA	370	-
PGC	340	-

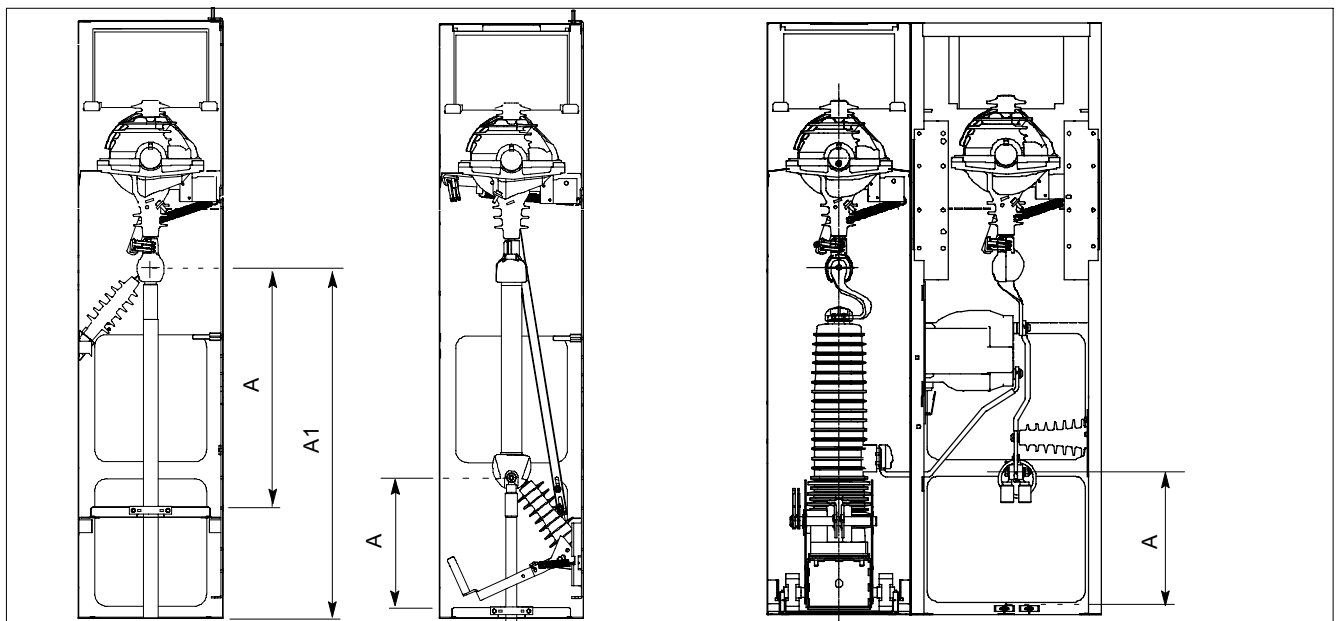

## 6.1 Geometry

Generally, HV cables penetrate into the room underground. They are routed along a cable trough or trench or through floor openings. These openings are to be calculated and carried out at the same time as the installation of the equipment to the floor.

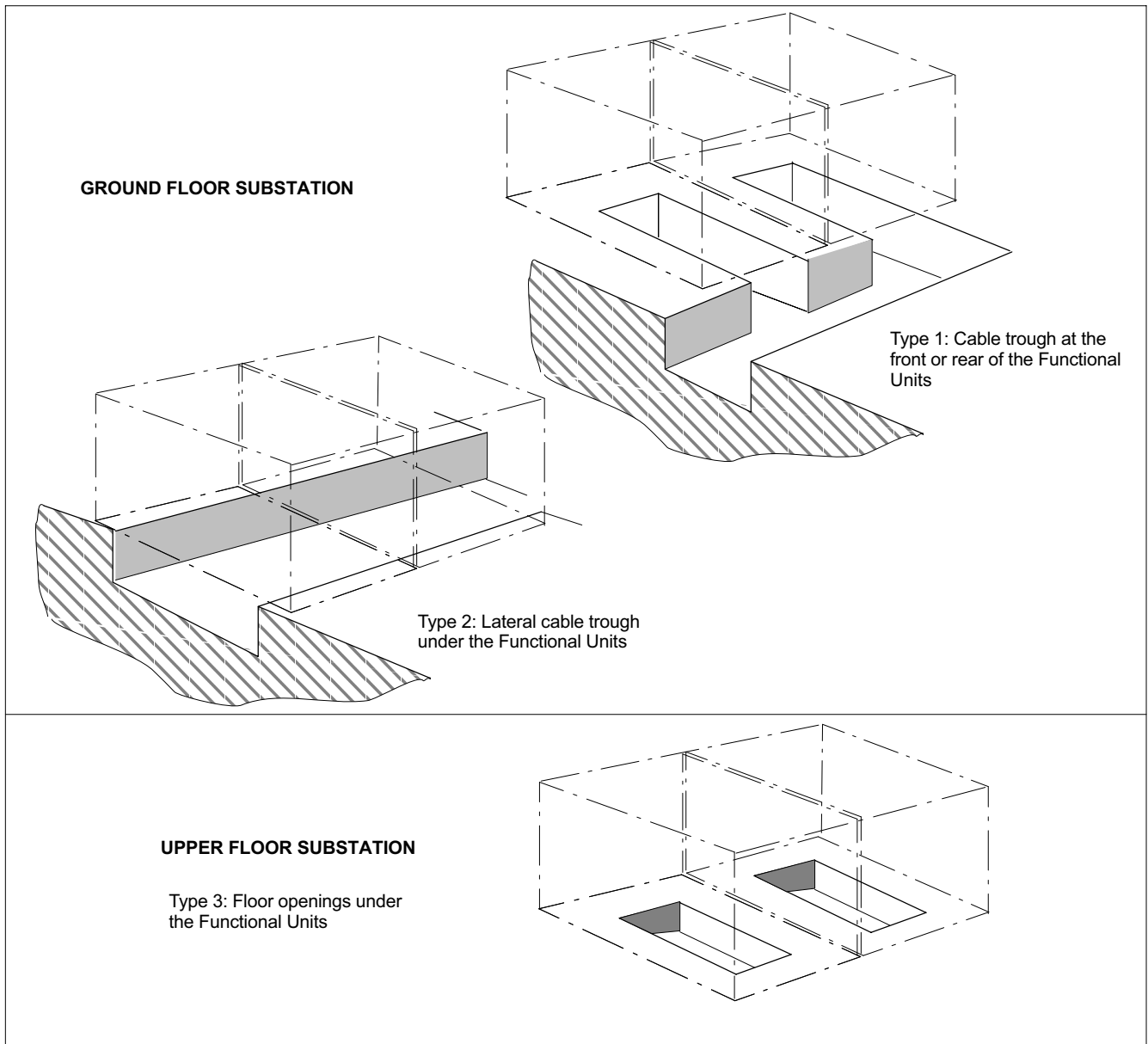

## 6.2 Special cases

Within the scope of renovation work, if the nature of the floor does not allow for works to be carried out or if the incoming of the cables is overhead, then the Functional Units can be raised.

In this case a mounting base is added to the lower part of each Functional Unit in order to facilitate the penetration of the cable and respect the bend radius necessary for its connection.

# 7 Civil Engineering without a metal section

## 7.1 Example of the installation of a switchboard in a conventional building

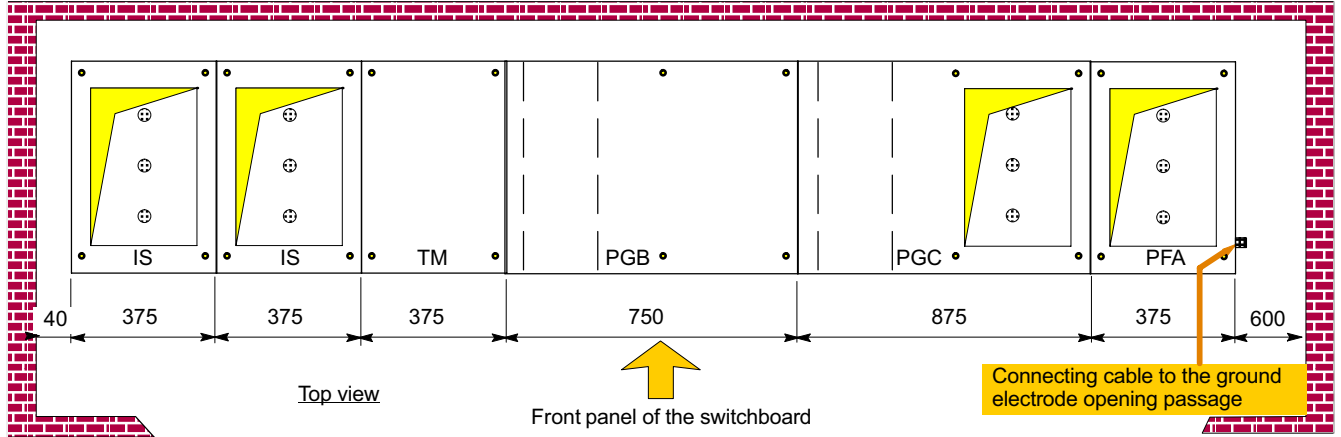

## 7.2 Work on the Civil Engineering structure

**NOTICE**  
This operation is not carried out by Schneider Electric.

The dressing of a top coat of cement using a rule should eliminate any surface irregularities greater than 2 mm per metre.

The overall flatness of the support surface should not show up any deflection greater than 6 mm throughout the length of the switchboard.

## 7.3 Advice that is appropriate for the various types of cable troughs

Types (See § 6.1)	Instructions
1	* Scrupulously respect: - the installation of the Functional Units on the floor, - the clearances and openings imposed depending on the type of Functional Unit, - the minimum distances in relation to the room and the service operations, - the state of finish of the floor slab.
2	* Scrupulously respect: - the clearances imposed depending on the type of Functional Unit, - the state of finish of the floor slab. * If the width of the cable trough exceeds 50 cm, follow the instructions in § 7.4.
3	* Scrupulously respect: - the clearances imposed depending on the type of Functional Unit, - the state of finish of the floor slab.

## 7.4 Layout on a type 2 cable trough, with width of more than 50cm

Whenever the width of the cable trough exceeds 50 cm, it is necessary to fit the longitudinal support irons to support the left and right-hand uprights for each Functional Unit.

Also fit the same longitudinal support irons under each of the rolling rails on Functional Units equipped with a circuit breaker.

**NOTICE**  
The support irons to be used are of 100mm min. IPN type.

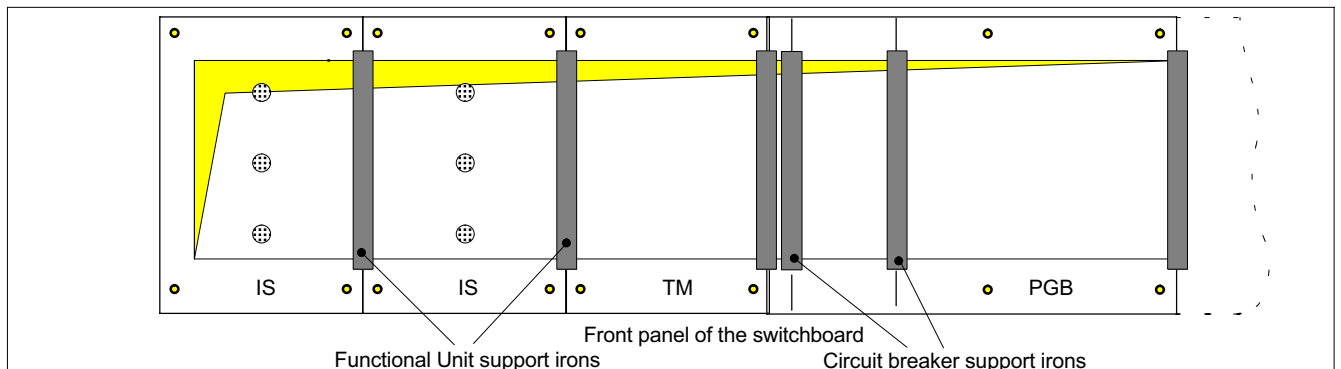

# 8 Civil Engineering structure with open metal sections

## 8.1 Mounting on metal sections called 'irons'

The mounting on irons facilitates alignment of the equipment and avoids shimming for the Functional Units.

The irons also serve in levelling the cement topcoat.

**NOTICE**

Sections and fixing bolts are not part of Schneider Electric's supply.

**Example of the open metal section**

1. HALFEN 40x22 section
  - hot rolled (L = 6 m)
  - load of 4,000 kg/metre
  - weight of 2.20 kg/metre
2. M12x30 hook bolt

## 8.2 Work on the Civil Engineering structure

**NOTICE**

This operation is not carried out by Schneider Electric.

### Preparation of the sections

Two profile sections must be laid out, one at the rear and one at the front, in the lengthwise direction of the switchboard.

Position these irons at the level of the holes for fixing the Functional Units to the floor.

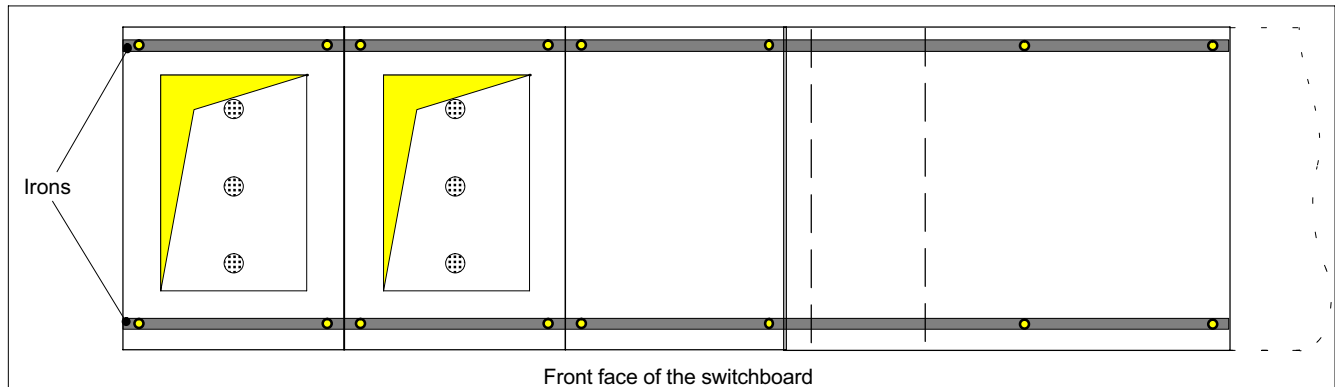

### Levelling the profile sections

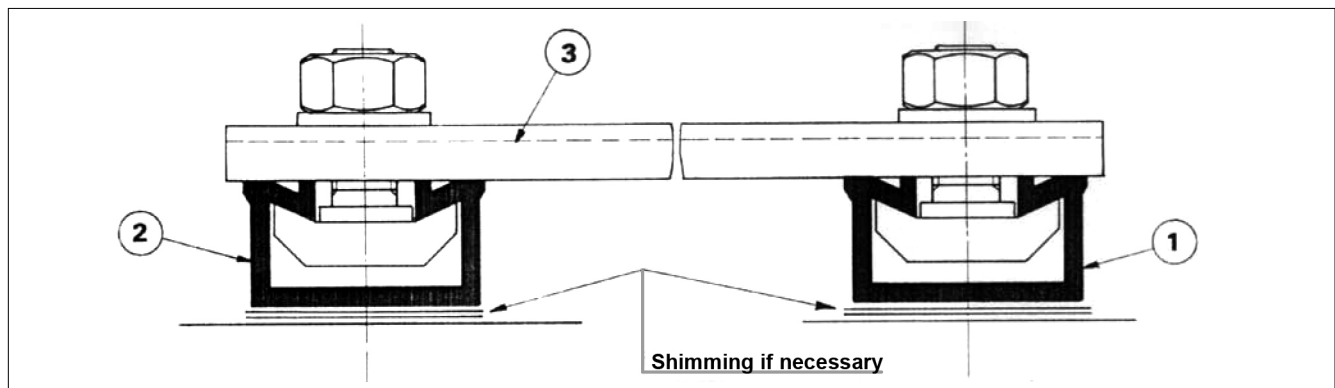

Connect the sections (1) and (2) by U shaped bars (3) about two metres apart (see below).

Fit shims below the sections (1) and (2) to set their level. They must be in the same horizontal plane.

Tolerance :  
Evenness fault  $\leq 2\text{mm/metre}$

**Reserve opening at the extremity of each rail**

At the extremity of each rail, provide for a formwork of 100x100x60 mm to insert the fixing bolts.

**NOTICE**

This space must be blocked off following assembly of the switchboard.

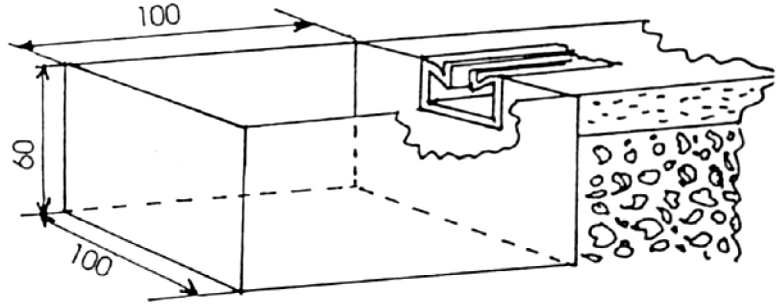

**Pouring the cement top coat**

Block off the irons to avoid penetration of cement into the rail.

On the un-surfaced exposed concrete, pour a top coat of smooth finish, without ballast.

Its thickness must be about 40mm of cement dosed at 500kg of CPA.

Using a trowel, pack the cement under the rails

**CAUTION**

The height of the top coat must arrive between 0 and 2mm below the height of the irons.

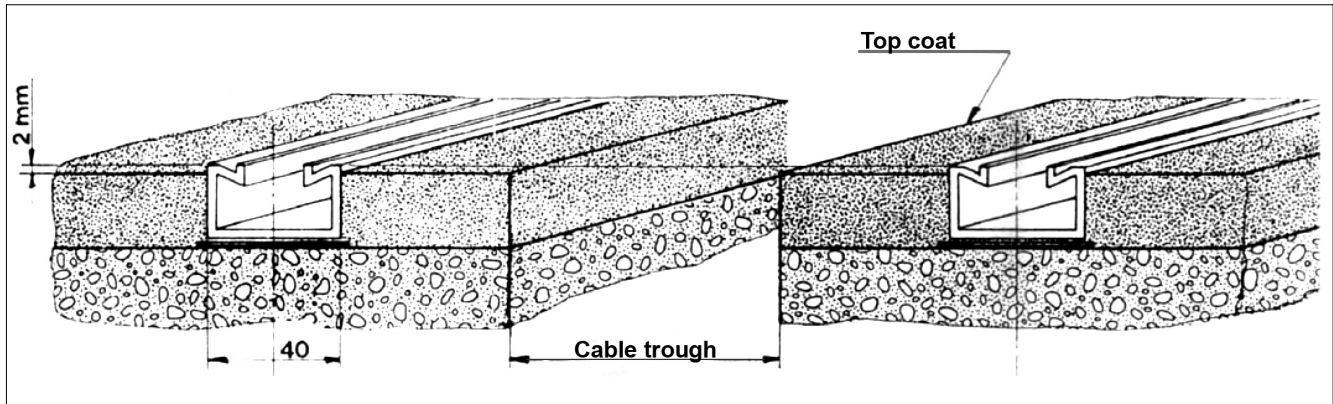

**Case of a type 2 cable trough**

In this case, fit the cross members in accordance with the instructions § 8.2.

# 9 Civil Engineering structure with metal sections on a slab

## 9.1 Mounting of metal profile sections on slabs

The mounting of irons on slabs also facilitates, as in § 9, the alignment of the equipment and avoids the shimming of the Functional Units.

**NOTICE**

Sections and fixing bolts are not part of Schneider Electric's supply.

**Example of a metal profile section on slabs**

- 1. U section 32x20x2
- 2. Support: Painted sheet steel (2 mm thick.).
- 3. HM8 bolts + M8 washers + HM8 nut

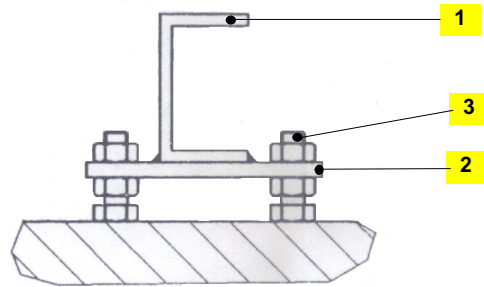

## 9.2 Preparation of the frame in profile sections

**NOTICE**

This operation is not carried out by Schneider Electric.

Each profile section comprises, every 750mm, a fixing plate welded and drilled with 2 holes of 10.2mm Ø. It is necessary for anchoring the profile sections to the floor.

Complete this assembly by the lateral irons. They will support the lateral uprights for the Functional Units and the rolling tracks for each circuit breaker (see § 7.2).

Make up a frame composed of two profile sections, laid out, one at the rear and one at the front, in the lengthwise direction of the switchboard.

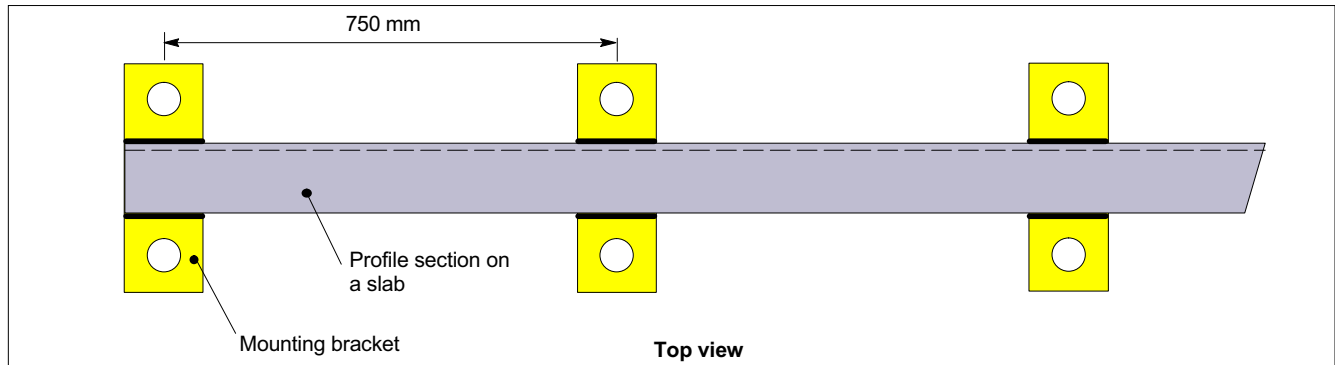

## 9.3 Installation of the frame

Determine the point zero for the main construction work. It will be the reference point for levelling the irons.

Realign the irons on the external face of each Functional Unit.

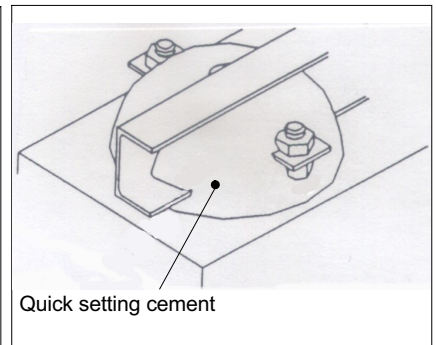
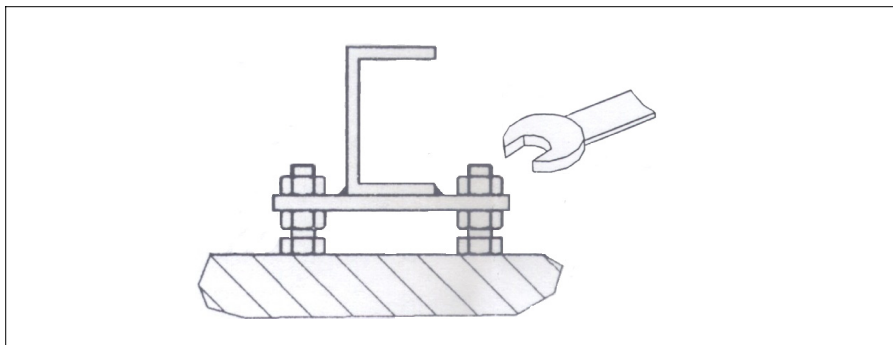
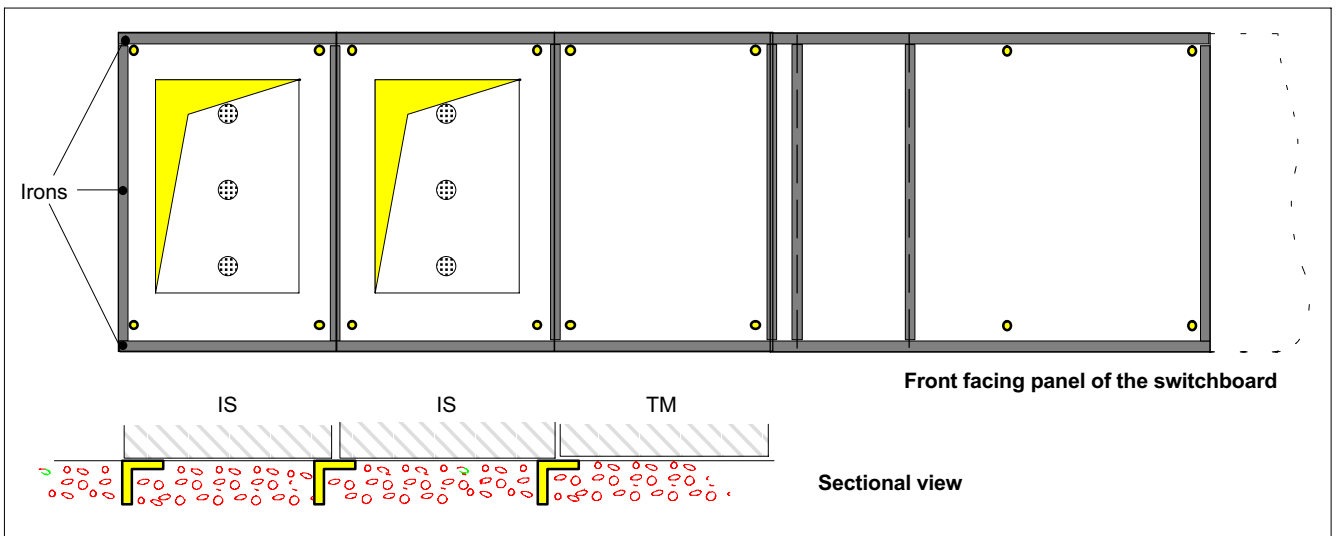

- Equip the support rails.
- Position and adjust the rails in height by acting on the adjusting nuts.

- Seal the rail supports with quick setting cement.

### 9.4 Pouring the cement top coat

On the un-surfaced exposed concrete, pour a top coat of smooth finish, without ballast. Its thickness must be about 70mm of cement dosed at 500kg of CPA. Using a trowel, pack the cement under the rails



The height of the top coat must arrive between 0 and 2mm below the height of the irons.

The drying time is to be determined by the person forming the top coat.

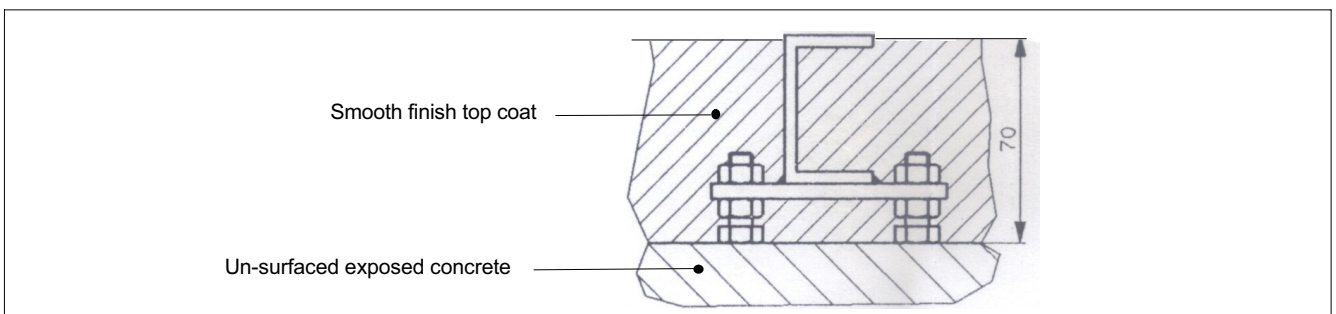

### 9.5 Installation of the switchboard at height, on a frame

The layout on the frame is equivalent to a layout on a mounting base supplied by Schneider Electric.

For this assembly, apply the same assembly instructions for the frame as for those detailed in chapter 9.2.



# 10 Connecting the switchboard to earth

## 10.1 Reserve opening for connecting the earthing circuit

The connection of the general earthing circuit is carried out on the switchboard's right-hand extremity, on the last Functional Unit.

This opening must have a section of about 40x40mm to allow for the passage of the 25mm<sup>2</sup> cable.

Its positioning is carried out in accordance with the sketch below.

Realign the passage on the front inner edge of the cable trough.

When the cable has passed and been connected, block up the opening with expanded polyurethane foam.

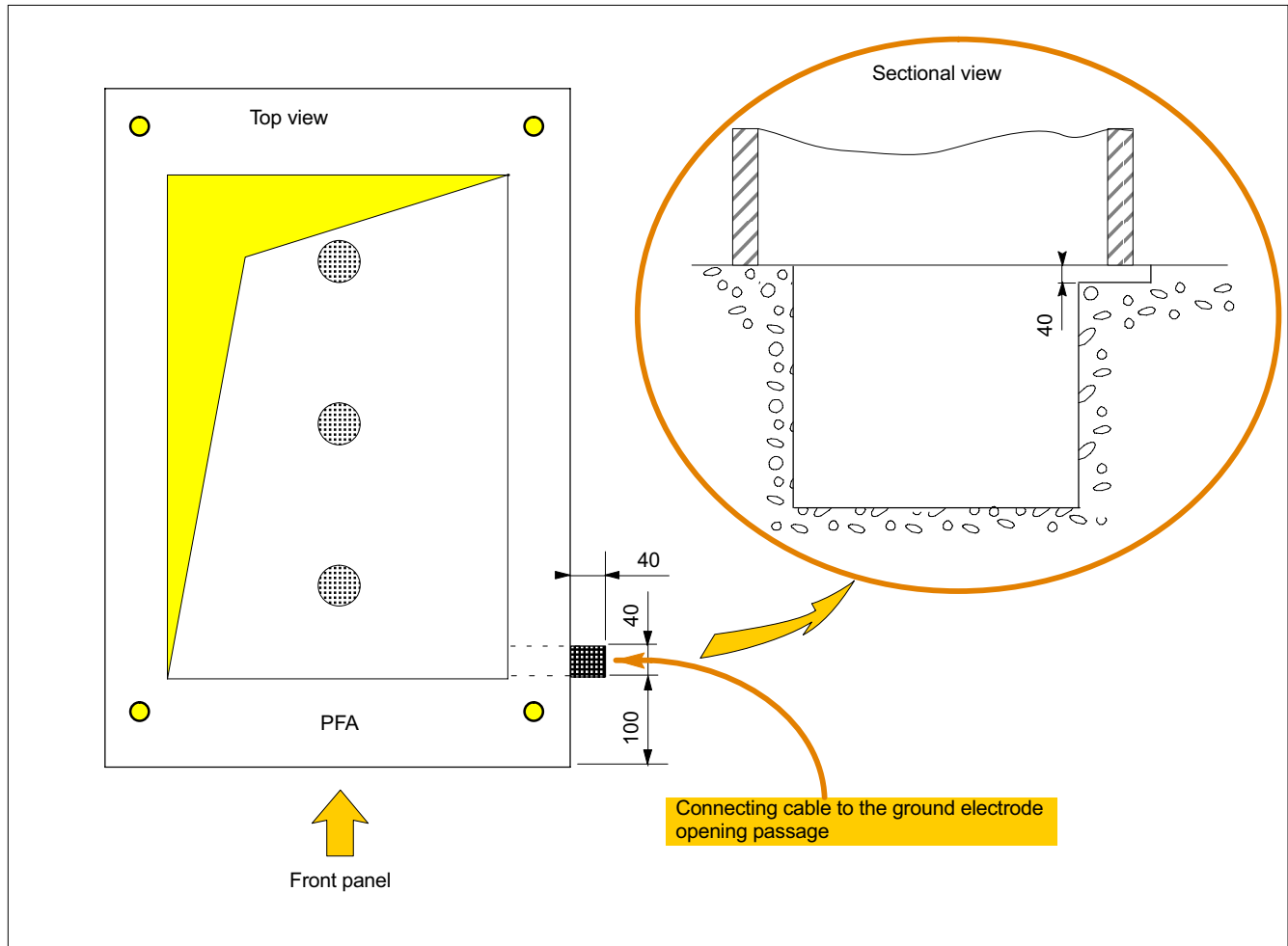

# 1 1 Last checks before installation of the Functional Units

## 11.1 Reading of the surface evenness

Before installation of the switchboard, proceed with measuring the evenness of top coat finishing.

On a rectangle whose largest dimension is the length of the switchboard + 100mm, and on a width of 2,000 mm, the gap must not be greater than 6 mm.

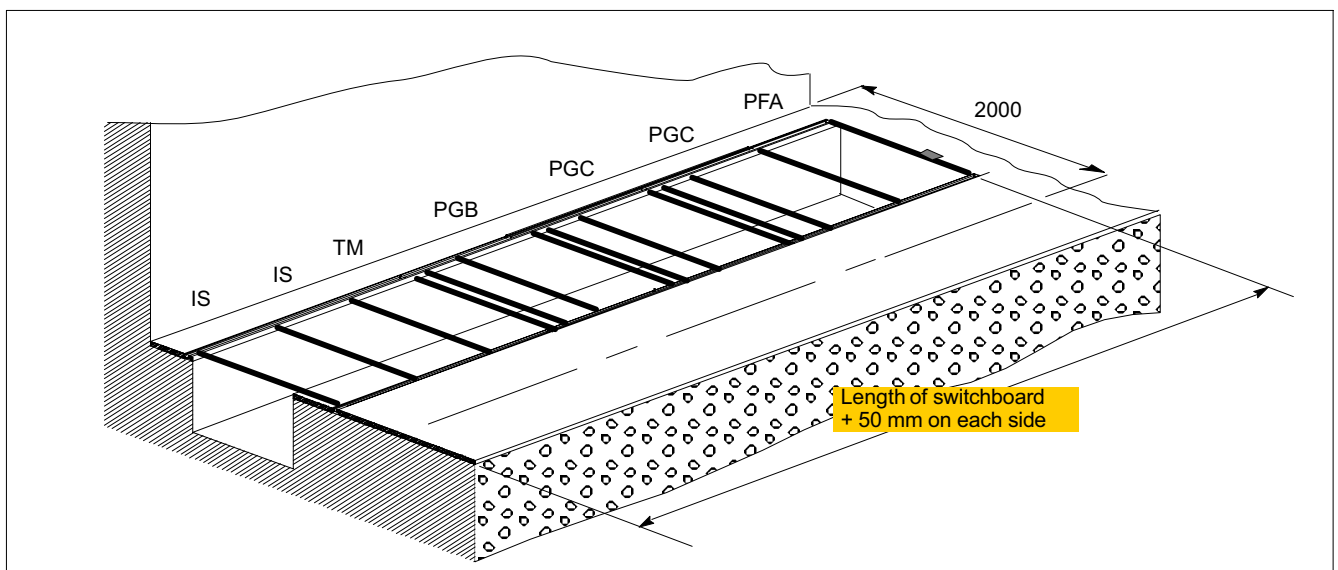

## 11.2 Layout of the Functional Units

On the floor, trace the position of the Functional Units.

Refer to the circuit breaker's technical manual (see § 2.4).

---

If you have any comments on the use of this document or on the use of the equipment and services that are described in it, please send us your remarks, suggestions and wishes to:

**Schneider Electric** Technical Department BP 84019 F-71040 Mâcon Cedex 9 - FRANCE

Fax: 33 (0)3 85 29 36 36

---

**Schneider Electric Energy France**  
35, rue Joseph Monier  
CS 30323  
F - 92506 Rueil-Malmaison Cedex

RCS Nanterre 511 746 356  
Capital social 6 909 620 €  
[www.schneider-electric.com](http://www.schneider-electric.com)

Due to possible changes in standards and equipment, the characteristics and images shown in this document can only be confirmed by contacting our departments.

Publication: Schneider Electric  
Design: Schneider Electric