

FPD-7024



EN | Operation and Installation Guide
Fire Alarm Control
Panel



BOSCH

FCC Compliance Notice

This equipment was tested and found to comply with the limits for a Class A digital device, pursuant to Part 15 of the FCC Rules. These limits are designed to provide reasonable protection against harmful interference in a residential installation. This equipment generates, uses, and can radiate radio frequency energy, and if not installed and used in accordance with the instructions, might cause harmful interference to radio communications. There is no guarantee that interference will not occur in a particular installation. If this equipment does cause harmful interference to radio or television reception, that can be determined by turning the equipment off and on, the user is encouraged to try to correct the interference by one or more of the following measures:

Re-orient or relocate the receiving antenna.

Increase the separation between the equipment and the receiver.

Connect the equipment into an outlet on a circuit different from that to which the receiver is connected.

Consult the dealer or an experienced radio or TV technician for help.

FCC Phone Connection to Users

This control panel complies with Part 68 of the FCC rules.

On the inside of the enclosure is a label that contains, among other information, the ringer equivalence number (REN) for this equipment. You must, upon request, provide this information to your local telephone company.

The REN is useful to determine the quantity of devices that can be connected to your telephone line and still have all of those devices ring when your telephone number is called. In most, but not all areas, the sum of the RENs of all devices connected to one line should not exceed five. To ascertain the number of devices that you can connect to your line, contact your local telephone company to determine the maximum REN for your local calling area.

This equipment can not be used on coin service provided by the telephone company. Do not connect this control panel to party lines. If this equipment causes harm to the telephone network, the telephone company might discontinue your service temporarily. If possible, they will notify you in advance. But if advance notice isn't practical, you will be notified as soon as possible.

You will be informed of your right to file a complaint with the FCC. The telephone company might make changes in its facilities, equipment, operations, or procedures that could affect the proper functioning of your equipment. If they do, you will be notified in advance to give you an opportunity to maintain uninterrupted telephone service.

If you experience trouble with this equipment, contact the manufacturer for information on obtaining service or repairs.

The telephone company might ask that you disconnect this equipment from the network until the problem is corrected or until you are sure that the equipment is not malfunctioning. The manufacturer, not the user, must make the repairs to this equipment.

To guard against accidental disconnection, there is ample room to mount the telco jack inside of the control panel cabinet.

The operation of this control panel might also be affected if events such as accidents or acts of God cause an interruption in telephone service.

Industry Canada Notice

The Industry Canada label identifies certified equipment. This certification means that the equipment meets certain telecommunications network protective, operational, and safety requirements. Industry Canada does not guarantee the equipment will operate to the user's satisfaction.

Before installing this equipment, users should ensure that it is permissible to be connected to the facilities of the local telecommunications company. The equipment must also be installed using an acceptable method of connection. The customer should be aware that compliance with the above conditions might not prevent degradation of service in some situations.

Repairs to certified equipment should be made by an authorized Canadian maintenance facility designated by the supplier. Any repairs or alterations made by the user to this equipment, or equipment malfunctions, might give the telecommunications company cause to request the user to disconnect the equipment.

Users should ensure for their own protection that the electrical ground connections of the power utility, telephone lines, and internal metallic water pipe system, if present, are connected together. Users should not attempt to make such connections themselves, but should contact the appropriate electric inspection authority, or electrician.

Trademarks

Microsoft[®], Windows[®], Windows NT[®] are either registered trademarks or trademarks of Microsoft Corporation in the United States and/or other countries.

CYCOLOY[®] is a registered trademark of General Electric Company.

POLYLAC[®] is a registered trademark of CHI MEI Industrial Corporation, LTD.

Chamber Check[®] is a registered trademark of Bosch Security Systems, Inc. in the United States.

CleanMe[™] is a trademark of GE Interlogix, Inc. in the United States and/or other countries.

Contents

1.0 Overview.....	7	3.3.2 FMR-7033 Keypad	26
1.1 System Overview.....	7	3.4 Testing.....	26
1.2 Components.....	8	3.4.1 Walk Test.....	26
1.2.1 On-board Conventional Points	8	3.4.2 Communicator Test.....	26
1.2.2 Off-board Addressable Points (with D7039 Multiplex Expansion Module).....	8	3.4.3 Call for Remote Programming	27
1.2.3 Enclosure Housing	8	3.4.4 Test Battery/NAC Circuits	27
1.2.4 Remote LCD Keypads.....	8	3.4.5 Answer for Remote Programming.....	27
1.2.5 Remote LED Annunciators	8	3.4.6 Manually Activate Outputs	27
1.2.6 D7032 with the D7030X Use	8	3.4.7 Read Zone Input Levels	27
1.2.7 Communicator.....	9	3.4.8 Addressable Point Test (MUX Test)	27
1.2.8 Users	10	3.4.9 Sensitivity Test.....	28
1.2.9 Lightning Protection	10	3.5 Point/Zone Mapping	28
1.2.10 Backup Battery Calculation.....	11	3.6 Personal Identification Numbers	30
1.2.11 Standby Existing Load.....	12	3.7 Communicator Operation	31
1.2.12 Compatible Devices	14	4.0 Programming.....	31
1.3 Parts List.....	16	4.1 Programming Features	32
1.4 Installing the Enclosure	16	4.2 Point Programming.....	33
1.5 Installing the FPD-7024.....	16	4.3 Alpha Programming	34
1.6 Installing Optional Equipment.....	17	4.4 Format Programming.....	35
2.0 Control Panel Terminal Connections.....	18	4.4.1 4/2	35
2.1 Power Supply Connections.....	19	4.4.2 BFSK	35
2.2 Option Bus Wiring Requirements.....	19	4.4.3 SIA	35
3.0 System Operation.....	21	4.4.4 Contact ID.....	35
3.1 Modes of Operation.....	21	4.4.5 3/1	35
3.1.1 Alarm	21	4.4.6 Modem IIIa ²	35
3.1.2 Supervisory.....	21	4.5 Program Menu Tree	36
3.1.3 Trouble	21	4.6 Shortcuts.....	38
3.1.4 Acknowledge.....	21	4.7 Remote Programming.....	39
3.1.5 Fire Silence/Reset.....	22	5.0 Control Panel Programming.....	40
3.1.6 Off-Normal Displays.....	22	5.1 PROG TIME	40
3.1.7 Normal.....	22	5.1.1 Program Time	40
3.2 Basic System Use	22	5.1.2 Automatic Test	40
3.2.1 Function Keys	22	5.1.3 Daylight Saving Time	41
3.2.2 Selecting Menu Items	22	5.2 SECURITY.....	41
3.2.3 After a Main Menu Item is Selected.....	23	5.2.1 Personal Identification Numbers (PIN).....	41
3.2.4 Returning to an Earlier Screen.....	23	5.2.2 Authority	42
3.2.5 Entering Data	23	5.3 PROG SYSTEM.....	43
3.2.6 Drill.....	23	5.3.1 Program Timers	43
3.2.7 Disable	23	5.3.2 AC Line Synch	45
3.2.8 History	23	5.3.3 Option Bus.....	45
3.3 Keypads.....	25	5.3.4 PIN REQUIRED.....	46
3.3.1 Built-in Keypad.....	25	5.3.5 Remote Programming.....	47
		5.4 PROG INPUTS	47
		5.4.1 Point Number	47
		5.4.2 Point Function	50

5.4.3	Point Copy	52	Appendix D: Programming.....	93
5.5	PROG OUTPUTS.....	53	Defaults List.....	93
5.5.1	Programming NACs.....	53	Appendix E: Phone Monitor Troubleshooting	97
5.5.2	Programming Relays	55	Specifications	98
5.6	PROG ACCOUNTS	58	Index	99
5.6.1	Phone Numbers/IP Addresses.....	58		
5.6.2	Phone Control.....	64		
5.6.3	Report Steering.....	65		
5.6.4	Ring Count.....	66		
5.6.5	Communication Tries.....	66		
5.6.6	Machine Bypass	66		
5.6.7	ALT. Comm	67		
5.7	PROG FORMATS	67		
5.7.1	4/2 Zone Report.....	67		
5.7.2	4/2 Report Codes	68		
5.7.3	BFSK Report Codes.....	69		
5.8	HISTORY DEFAULTS.....	70		
5.8.1	Clear History.....	70		
5.8.2	Default EE.....	70		
5.8.3	Alternate 4/2 Codes	71		
5.9	Program MUX	71		
5.9.1	MUX Edit.....	71		
5.9.2	MUX Program	72		
5.9.3	MUX Bus Type.....	73		
5.9.4	Auto Program.....	74		
5.9.5	Removing MUX Devices	77		
6.0	Installation Guide for UL Listed Systems	79		
6.1	FPD-7024 UL Listings.....	79		
6.2	Installation Considerations.....	79		
6.3	Programming the FPD-7024.....	79		
6.3.1	Commercial Fire Alarm (Central Station [DACT] and Local).....	79		
6.3.2	UL Listed Accessory Devices	79		
	D185 Reverse Polarity Module.....	81		
7.0	Fire Safety	82		
7.1	Smoke Detector Layout.....	82		
7.1.1	General Considerations.....	82		
7.1.2	Installing Family Residences	82		
7.2	Having and Practicing an Escape Plan.....	83		
	Appendix A: Abbreviations on Control Panel Display	84		
	Appendix B: Control Panel Display Descriptions	85		
	Appendix C: Reporting Summary for Fire Communicator	86		

Figures

Figure 1:	FPD-7024 Control Board.....	7
Figure 2:	Supplemental Reporting.....	10
Figure 3:	Enclosure Installation.....	16
Figure 4:	Standoff and Support Post Installation..	17
Figure 5:	FPD-7024 Control Panel Terminal Connections	18
Figure 6:	Connecting the Transformer to the FPD-7024 Circuit Board	19
Figure 7:	Option Bus Cable Length vs Current Draw	21
Figure 8:	Built in Keypad.....	25
Figure 9:	FMR-7033 Keypad.....	26
Figure 10:	Mapping, Inputs, Zones, and Outputs ...	29
Figure 11:	Essential Keys for Alpha Programming	35
Figure 12:	Example of a Programming Shortcut	38
Figure 13:	D7039 Mounting Location	74
Figure 14:	Wiring the D132B-Smoke Power Reversing Module	80
Figure 15:	Wiring the D185.....	81
Figure 16:	Smoke Detector locations in Residential Setting	82

Tables

Table 1:	Two-Wire Circuits	8
Table 2:	LED Assignments for LED Annunciators 4 and 8.....	9
Table 3:	LED Display for Zone 49 to 64	9
Table 4:	Standby Battery Capacity Calculations.	11
Table 5:	Required Battery Size Calculation	12
Table 6:	Standby Load Battery Size (Ah).....	12
Table 7:	Alarm Load Battery Size (Ah).....	13
Table 8:	Compatible Devices	14
Table 9:	Address Restrictions for the D7042, D7052, and D7053	15
Table 10:	Option Bus Wiring Guidelines	20
Table 11:	Off-Normal Displays.....	22
Table 12:	History Event Abbreviations.....	24
Table 13:	Pre-Assigned Zones	29
Table 14:	PIN Authority Levels	30
Table 15:	Programming Features for UL864.....	32
Table 16:	Point Function Characteristics	33
Table 17:	Programming the Points Using the Alphanumeric	34
Table 18:	PIN Authority Levels.	42
Table 19:	Pre-Assigned Zone Quick Reference....	54

Table 20:	Pre-Assigned Zone Quick Reference....	56
Table 21:	Pre-Assigned Zone Quick Reference....	57
Table 22:	Phone Number Control Characters	59
Table 23:	Phone Number Assistance Keys	59
Table 24:	IP Address Digit or Bit Location.....	60
Table 25:	Phone Reporting.....	61
Table 26:	Auto Programming Error Messages	76
Table 27:	Abbreviations on Control Panel Display	84
Table 28:	Control Panel Display Descriptions	85
Table 29:	Reporting Summary for Fire Communicator.....	86
Table 30:	Modem IIIa ² Reporting.....	88
Table 31:	History Log	92
Table 32:	Specifications.....	98

1.0 Overview

1.1 System Overview

 This guide applies to control panels equipped with version V1.00 or later software.

The FPD-7024 Fire Alarm Control Panel is a fully integrated hard-wire fire alarm system. It can support four input points (expandable to 255 using D7039 Multiplex Expansion Module and the FPC-7034 Four-Point Expander) and 16 individual users (expandable to 100 with the D7039). The control panel has a built-in LCD keypad. Up to four additional keypads can be used to provide user interface with the system and programming access for the installer. The FPD-7024 also includes the following features:

- Built-in dual-line communicator

- Menu driven keypad programming
- Freely programmable alphanumeric/alphabetical display
- 99 event history buffer
- 16 user codes
- UL Listed, CSFM, MEA Approved

When the D7039 Multiplex Expansion Module is installed, these additional features are available:

- 247 additional addressable input points (255 total points)
- 499 Non-volatile event history buffer
- 100 user codes

Refer to *Figure 1* for the location of the major items on the FPD-7024 Control Board.

Figure 1: FPD-7024 Control Board

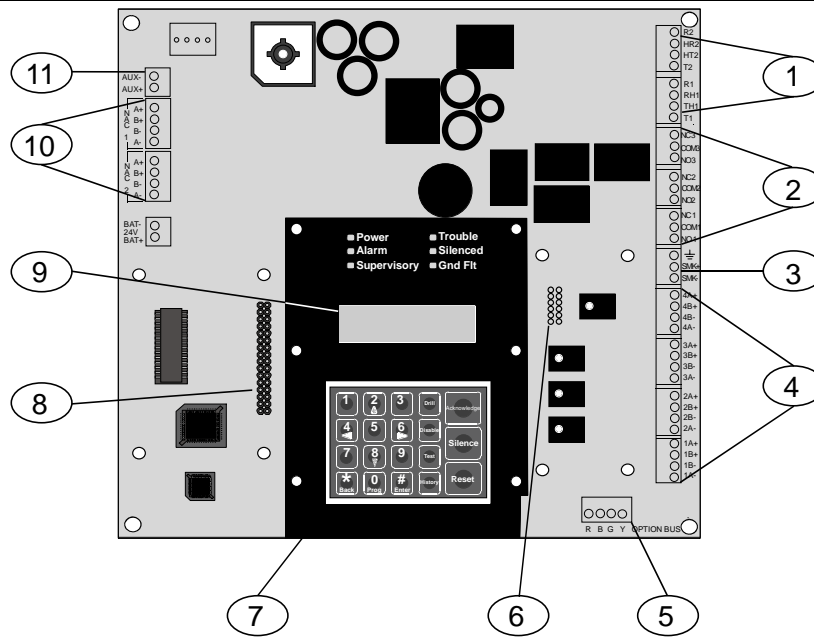

- | | |
|--|---|
| 1 - Telco Terminal Strip | 7 - Keypad |
| 2 - Relay Terminal Strip | 8 - D7039 MUX Expansion Module Connector Pins |
| 3 - Smoke Power Terminal Strip | 9 - LCD Display |
| 4 - Zone Input Terminal Strip | 10 - NAC Terminal Strip |
| 5 - Option Bus Terminal Strip | 11 - Auxiliary Power Terminal Strip |
| 6 - FPC-7034 Point Expander Connector Pins | |

1.2 Components

1.2.1 On-board Conventional Points

All on-board points and points implemented with the FPC-7034 work with two- or four-wire detectors. The system has an optional alarm verification feature.

Table 1: Two-Wire Circuits	
Number of two-wire circuits	Four circuits, expandable to eight using an FPC-7034 Expander
Type of Circuit	Class B, Style B and Class A, Style D as needed)
EOL Resistor	2.21 kΩ (P/N: 25899 or F01U034504), UL listed
Supervisory Existing	8 to 20 mA
Required Existing for Alarm	25 mA
Maximum Short Circuit Existing	45 mA
Maximum Line Resistance	150Ω
Circuit Voltage Range	20.4 to 28.2 VDC
Maximum Detectors per Point	20 detectors (two-wire)
Total Detector Standby Existing	3 mA maximum
Response Time*	Either fast (500 ms) or programmable (from 1 to 89 seconds)
Dirty Detector Monitoring	Implements Bosch Security Systems, Inc. Chamber Check® and GE Interlogix, Inc. CleanMe™ protocol to monitor conventional loops for dirty detectors.

* Refer to Section 6.4 on page 81.

All on-board points, and points activated with the FPC-7034 Four Point Expander, are continuously monitored for detectors signaling a dirty condition using the Bosch Security Systems, Inc. Chamber Check and GE Interlogix, Inc. CleanMe protocols. To prevent nuisance reports, a two-minute delay occurs before a dirty detector is annunciated. A six-minute delay occurs after the detector restores from the dirty condition before the control panel restores the condition.

1.2.2 Off-board Addressable Points (with D7039 Multiplex Expansion Module)

The D7039 Multiplex Expansion Module adds:

- Two Class B, Style 4 or one Class A, Style 6 Signaling Line Circuits (SLCs)
- Each point is individually supervised for proper connection to the common bus (when over ten points are troubled, up to ten troubles are shown per bus and the balance of the troubles is indicated by a common bus failure message).
- Response time can be set to fast, or programmed from 1 to 89 seconds.
- Input points on the SLCs are implemented with a D7042 Eight Input Remote Module.

1.2.3 Enclosure Housing

The standard enclosure is 18 ga., cold-rolled steel, and measures 20.75 in. x 15 in. x 4.25 in. (52.7 cm x 38.1 cm x 10.8 cm). A keyed lock is included, and the LEDs and LCD display are visible through the door.

1.2.4 Remote LCD Keypads

Maximum number of keypads: Four FMR-7033 LCD Fire Keypads.

Wiring Requirements: Refer to Section 2.2 Option Bus Wiring Requirements on page 19.

1.2.5 Remote LED Annunciators

Maximum number of annunciators: Eight D7030 eight-zone LED Annunciators.

Wiring Requirements: Refer to Section 2.2 Option Bus Wiring Requirements on page 19.

1.2.6 D7032 with the D7030X Use

When a D7032 Eight-Zone LED Annunciator Expander is connected to the D7030X, eight additional LED zones appear. This allows the D7030X/D7032 combination to show 16 LED zones. Up to eight D7030X/D7032 combinations can be connected to the FPD-7024 Fire Alarm Control Panel. Refer to Table 2 on page 9 for zones shown by each D7030X/D7032 combination.



Each D7030X processes 16 zones of information. If no D7032 is attached, only the lower eight zones are shown.



The column labeled Shown on D7030X” In Table 2 on page 9 applies regardless if an attachment of a D7032 to any D7030X is made.

D7030X	Zones Covered	Shown on 7030X	Shown on D7032 (if attached)	COMMENTS
1	1 to 16	1 to 8	9 to 16	Combination with lowest option bus address (such as Address 1)
2	17 to 32	17 to 24	25 to 32	Combination with second lowest option bus address (such as Address 2)
3	33 to 48	33 to 40	41 to 48	Combination with third lowest option bus address (such as Address 3)
4	49 to 64	49 to 56	57 to 64	Combination with fourth lowest option bus address (such as Address 4)
5	1 to 16	1 to 8	9 to 16	Fifth combination repeats first combination
6	17 to 32	17 to 24	25 to 32	Sixth combination repeats second combination
7	33 to 48	33 to 40	41 to 48	Seventh combination repeats third combination
8	49 to 64	49 to 56	57 to 64	Eighth combination repeats fourth combination

Refer to *Table 3* for the LED display for Zones 49 to 64.

LED	Zone	Description
1	49	User defined
2	50	User defined
3	(reserved)	
4	52	General fire alarm monitor waterflow (non-silencable)
5	53	General fire alarm monitor (silencable)
6	(reserved)	
7	55	General Supervisory (silencable)
8	56	General Waterflow (silencable)
9	(reserved)	
10	58	General supervisory alarm (non-silencable)
11	(reserved)	
12	(reserved)	
13	61	General waterflow alarm (non-silencable)
14	(reserved)	
15	63	General alarm monitor waterflow (non-silencable)
16	(reserved)	

1.2.7 Communicator

The communicator can report to two phone numbers or IP addresses with full single, double, and back-up reporting. Communicates in SIA, Modem IIIa2, Contact ID, BFSK, and 3/1 and 4/2 Tone burst formats.



The communicator must be enabled and configured to operate. The communicator and phone line monitors are disabled in the default factory configuration.

Phone Line and Phone Number/IP Selection: To ensure the delivery of critical reports, the fire panel has two phone lines and two phone numbers or IP addresses that can be used for reporting. Reports can be directed to one or both of two phone numbers or IP addresses using the Report Steering feature (refer to *Section 5.6.3 Report Steering* on page 65) in the control panel programming. Note that Account Number 1 is used with Phone Number/IP 1, and Account Number 2 is used with Phone Number/IP 2. Except for test reports, the control panel automatically selects the phone line or IP address to use. If the report is not successful after two attempts on Line 1, the control panel automatically switches and uses Phone Line 2. One exception is when test reports (manual or automatic) are sent. Test reports are sent every 4 hours to 28 days. Each time a Test report is sent, the control panel alternates phone lines. This happens even if the monitor says the line is bad. If the user sends two manual test reports both phone lines can be tested. The first report uses one line and the second uses the other line. During normal operation, the automatic test uses a different line each day.

Because the control panel automatically selects which line to use, both phone lines must use the same dialing sequences for sending reports. For example, a line that requires a 9 to be dialed for an outside line cannot be paired with a line that does not require a 9.

 PBX lines and ground start phone lines do not comply with NFPA requirements for digital communication.

While the control panel is idle, the FACP monitors the primary and alternate telephone lines by monitoring the line for trouble. The FACP monitors each line every 12 seconds. When a trouble still exists after three samples (36 seconds), the FACP sends a trouble report and activates the yellow trouble LED and trouble relay.

 If the central station receives the automatic test report only every other day, this indicates that one phone line at the protected premises is inoperative. Correct this condition immediately, because other critical reports can be delayed when the communicator is trying to send the test signal through the inoperative phone line (once each 48 hours).

Supplemental Reporting: While two independent phone lines are required for UL864 Central Station service, the FACP can be configured with one phone line if the control panel is used only for supplemental reporting on a local, remote station or auxiliary system.

Connect a jumper from T1 to T2 and R1 to R2 if the control panel is installed with only one phone line. Refer to *Figure 2*.

 Control panel reports can be delayed if the dialer outputs are not connected together on an installation where the control panel has only one phone line

Figure 2: Supplemental Reporting



- 1 - Jumper from R1 to R2
- 2 - Jumper from T1 to T2
- 3 - House phone
- 4 - Telco Line

1.2.8 Users

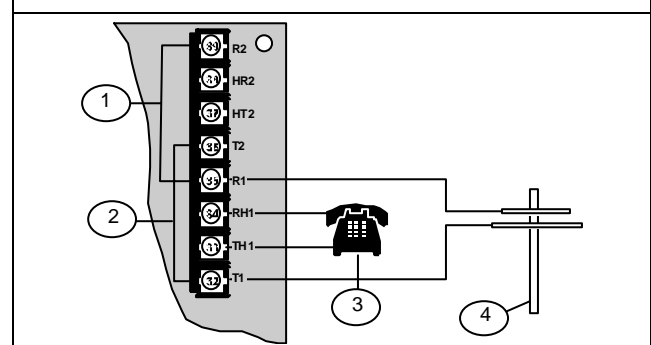
The system allows up to 16 individual users, or up to 100 users when the D7039 is installed. A personal identification number (PIN) the four-digit code entered at the keypads, and an authority level to determine which functions can be performed (refer to *Section 5.2.1 Personal Identification Numbers* on page 41) can be assigned to each user.

1.2.9 Lightning Protection

 This system is intended for installation entirely within one building.

Metal-oxide varistors (MOV) and spark gaps provide protection from lightning surges and static discharges.

1.2.10 Backup Battery Calculation

Use *Table 4* to calculate the standby battery capacity required by NFPA when using the FPD-7024.

Table 4: Standby Battery Capacity Calculations					
Device	Quantity	Standby Existing/Device	Total Standby	Alarm Existing/Device	Total Alarm
FPD-7024 Control panel	1	200 mA	200 mA	380 mA	380 mA
FPC-7034 Four-Point Expander		44 mA		156 mA	
D7035/B Octal Relay ¹		8 Ma + 30 mA ²		8 Ma + 30 mA ²	
D7048/B Octal Driver Module		10 mA		10 mA	
FMR-7036 Annunciator Keypad		80 mA		100 mA	
D7030X Eight-Point LED Annunciator ¹		27 mA		132 mA	
D7030X-S2 Eight-Point LED Annunciator		35 mA		175 mA	
D7030X-S8 Eight-Point LED Annunciator		35 mA		175 mA	
D7032 Eight-Point LED Annunciator Expander		1 mA		90 mA	
FMR-7033 Keypad ¹		80 mA		100 mA	
D7039 MUX Expansion Module		150 mA		150 mA	
D7042/B Addressable Eight Point Input		18 mA		18 mA	
D7050 MUX Photoelectric Smoke Detector		0.50 mA		0.56 mA	
D7050TH MUX Photoelectric Smoke Detector		0.50 mA		0.56 mA	
FMM-7045 Mux Pull Station		0.55 mA		0.55 mA	
D7044 Mux Single Input Fire		0.55 mA		0.55 mA	
D7044M Mux Mini Contact Module		0.55 mA		0.55 mA	
D7052 Mux Dual Input Fire		0.55 mA		0.55 mA	
D7053 Mux I/O Module Fire		0.70 mA		0.70 mA	
Smoke Detectors					
Bells, Horns, and so on					
Other Sensors					
Other					
		Grand Total Standby Existing		Grand Total Alarm Existing	

¹ The 24 VDC existing requirements for the D7030X, FMR-7033 and D7035 are shown at 75% of the 12 VDC level shown on the specification sheets for these models. The FPD-7024 regulates 24 VDC power from the battery to 12 VDC for these accessories.

²Add 30 mA for each relay activated

The units shown in *Table 5* are Amp hours (Ah), and the figures include a 20% derating factor.

Table 5: Required Battery Size Calculation		
Grand Total Standby Existing (in amps)	CS	
Total Hours of Standby Required (usually 24 or 60):	HS	
Total Standby Capacity (multiply CS X HS)	TS= CS X HS	
Grand Total Alarm Existing (in amps)	CA	
Total Hours of Alarm Time Required (usually 0.083 or 0.25):	HA	
Total Standby Capacity (multiply CA X HA)	TA= CA X HA	
Total Capacity Required (add TA + TS):	TC = TA + TS	
Required Capacity with 20% Derating (TC X 1.2)	C = TC X 1.2	



The required battery size to support the system can be calculated using *Table 6* and *Table 7* on page 13.

1.2.11 Standby Existing Load

Use *Table 6* to estimate the size of the battery required to support the standby load, then use *Table 7* on page 13 to estimate the size of the battery required to support the alarm load. Add the results together for the total battery size. Select the next larger standard battery for the system. If the results show a requirement for a battery over 40 Ah, reduce the existing or add an external regulated fire protective signaling power supply.

Table 6: Standby Load Battery Size (Ah)			
Standby Load Battery Size Chart	Capacity Required for 24 Hours	Capacity Required for 48 Hours	Capacity Required for 60 Hours
Grand Total Standby Existing			
100 to 200 mA	5.8	11.5	14.4
201 to 300 mA	8.6	17.3	21.6
301 to 400 mA	11.5	23.0	28.8
401 to 500 mA	14.4	28.8	36.0
501 to 600 mA	17.3	34.6	X
601 to 700 mA	20.2	X	X
701 to 800 mA	23.0	X	X
801 to 900 mA	25.9	X	X
901 to 1000 mA	28.8	X	X
1001 to 1100 mA	31.7	X	X

Table 7: Alarm Load Battery Size (Ah)

Alarm Load Battery Size Chart	Capacity Required for 5 Minutes	Capacity Required for 10 Minutes	Capacity Required for 15 Minutes	Capacity Required for 30 Minutes	Capacity Required for 45 Minutes
Grand Total Standby Existing					
250 to 500 mA	0.1	0.1	0.2	0.3	0.5
501 to 999 mA	0.1	0.2	0.3	0.6	0.9
1.0 to 1.5 A	0.2	0.3	0.5	0.9	1.4
1.6 to 2.0 A	0.2	0.4	0.6	1.2	1.8
2.1 to 2.5 A	0.3	0.5	0.8	1.5	2.3
2.6 to 3.0 A	0.3	0.6	0.9	1.8	2.7
3.1 to 3.5 A	0.4	0.7	1.1	2.1	3.2
3.6 to 4.0 A	0.4	0.8	1.2	2.4	3.6

1.2.12 Compatible Devices

Table 8: Compatible Devices	
Device	Function
D7030 Eight Point LED Annunciator	Identifies the location of a fire alarm for up to eight zones allowed per system.
D7030X Eight Point LED Annunciator	Identifies the location of a fire alarm for up to eight zones allowed per system.
D7030X-S2 Eight Point LED Annunciator	An eight-zone LED annunciator, of which two zones are reserved for supervisory functions. It has Power and Trouble LEDs plus eight-zone LEDs that can be labeled individually.
D7030X-S8 Eight Point LED Annunciator	An eight-zone LED annunciator, of which all eight zones are reserved for supervisory functions. It has Power and Trouble LEDs plus eight-zone LEDs that can be labeled individually.
D7032 Eight Point LED Annunciator Expander	Attaches to a D7030X and identifies the location of a fire alarm for eight additional zones.
FMR-7033 Alphanumeric LCD Keypad	Connects up to four-keypads per system.
FPC-7034 Four Point Expander	Allows the FPD-7024 Control Panel to support four additional points. The FPC-7034 plugs into the control panel and provides four Class B, Style 4 loops that are identical in characteristics to the loops on the control panel. One FPC-7034 is allowed per system.
D7035/B Octal Relay Module	Provides eight Form C relay outputs for addition to the system. The outputs are programmable and can be activated by system events. Each output operates independently of the other seven outputs for complete flexibility. The D7035 connects to the option bus; up to two are allowed per system. Refer to the <i>D7035 Installation Guide</i> (P/N: 37280) for required enclosure modification. The D7035B comes installed on a mounting skirt.
FMR-7036 Fire Annunciator Keypad	Establishes the location of a fire alarm.
FPP-RNAC-8A-4C Remote NAC Power Supply	Adds four NFPA 72 Class B, Style Y Notification Appliance Circuits through the option bus and is supervised by the control panel. The FPP-RNAC-8A-4C connects to the option bus of the FPD-7024 control panel and up to four are allowed per system.
D7039 Multiplex Expansion Module	Provides either 2 two-wire (Class B, Style 4) multiplex buses or 1 four-wire (Class A, Style 6) multiplex bus. In Class A mode, up to 120 addressable points can be added. In Class B Mode, up to 247 addressable points can be added. The D7039 connects directly to the control panel. One is allowed per system.
D7042/B Eight-Input Remote Module	Provides eight Class B, Style 4 input points. Connect up to 15 modules to MUX Bus A, and 15 on MUX Bus B. The D7042 is powered by 12 VDC supplied by the option bus power terminals, in addition to the two-wire data connection. The D7042 can not be used on a signal line circuit (SLC) configured for Class A, Style 6 operation.
D7048/B Octal Driver Module	Provides eight open collector transistor outputs for addition to the FPD-7024 Fire Alarm Control panels. It connects to the control panels through the option bus.
FMM-7045 Mux Pull Station	UL Listed fire alarm initiating device.
D7044 Mux Single Input Fire	Connects a contact device to the multiplex bus of the FPD-7024 with a supervised local loop. The D7044 draws operating power from the FPD-7024.
D7044M Mux Mini Contact Module	Connects a contact device to the multiplex bus of the FPD-7024 with a supervised input loop. The D7044 draws operating power from the FPD-7024.

Table 8: Compatible Devices (continued)

D7052 Mux Dual Input Fire	Connects to the multiplex bus of the FPD-7024 and provides two supervised input zones for connecting conventional normally-open inputs. The D7052 draws operating power from the FPD-7024.
D7053 Mux I&O Module Fire	Connects to the multiplex bus of the FPD-7024 and implements a supervised local loop, and a Form C relay output. Up to 20 modules can be connected to each MUX bus. The D7053 draws operating power from the FPD-7024.
D7050/TH Mux Smoke Detector	The D7050/TH is a photo-electric smoke detector with a heat option. It connects to the multiplex bus of the FPD-7024. The D7050 draws operating power from the FPD-7024.

Table 9: Address Restrictions for the D7042, D7052, and D7053

Install D7042 modules only at addresses:							
9	17	25	33	41	49	57	65
73	81	89	97	105	113	121	129
137	145	153	161	169	177	185	193
201	209	217	225	233	241		
Do not install D7052 and D7053 modules at these addresses							
16	24	32	40	48	56	64	72
80	88	96	104	112	120	128	136
144	152	160	168	176	184	192	200
208	216	224	232	240	248	255	

1.3 Parts List

- One FPD-7024 Control/Communicator in static-resistant bag
- One enclosure with transformer
- One hardware pack
- One enclosure lock, washer, and keys
- Six end-of-line (EOL) resistors

The hardware necessary for installing the control panel in the enclosure is located in the hardware pack.

1.4 Installing the Enclosure

1. Using the enclosure as a template, mark the top mounting holes on the mounting surface (*Figure 3*).
2. Start the mounting screws (not supplied) for these two holes.
3. Slide the enclosure onto these screws so that the screws rest on the thinner section of the holes.
4. Tighten the screws.
5. Install and tighten the remaining two screws in the bottom mounting holes.
6. Knock out the desired wire entrances on the enclosure.

Figure 3: Enclosure Installation

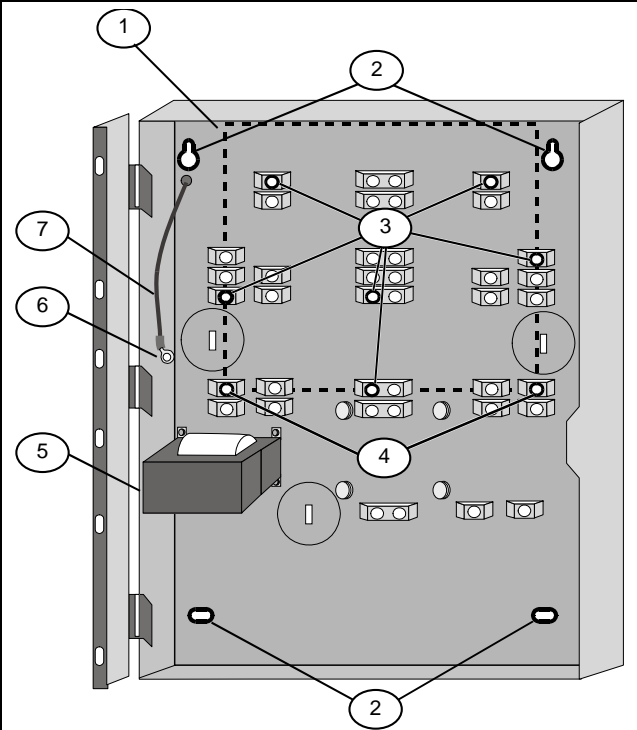

- 1 - Control panel location
- 2 - Mounting holes
- 3 - Retainer holes for standoffs
- 4 - Retainer holes for support posts
- 5 - Transformer
- 6 - Stud
- 7 - Ground wire



If using the knockouts located at the bottom of the enclosure install batteries in a separate enclosure.

1.5 Installing the FPD-7024



The control circuit board in the FPD-7024 is static sensitive. Touch ground before handling the control board. This discharges any static electricity in your body. For example, run the ground wire to the enclosure before handling the control circuit board. Continue touching the enclosure while installing the control board.

1. Insert the three support posts in the enclosure's retainer holes. Refer to *Figure 3* above and *Figure 4* on page 17.
2. Press the 1/8 in. nylon standoffs (P/N: F01U034705) into the retainer holes.

3. Slide the top of the control panel onto the retainer tabs (the slots under the top of the frame). When the control panel is in the retainer tabs, it rests on the posts.
4. Secure the bottom of the circuit board by inserting and tightening the screws at the two bottom corners through the support posts and the retainer holes *Figure 4*.

 Connect the supplied ground wire between the door and the enclosure using the supplied nuts before the circuit board is installed.

A second ground wire is provided for connecting the AC power ground. Both grounds connect to the stud in the enclosure to the left of the circuit board. Refer to *Figure 3* on page 16.

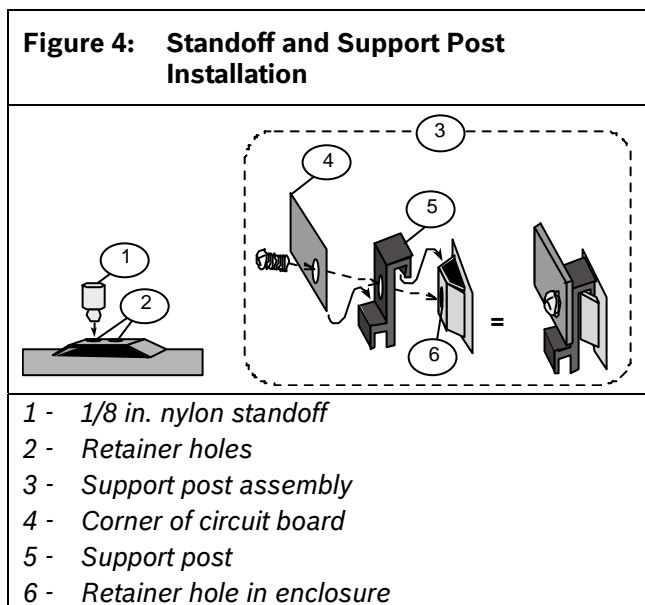

1.6 Installing Optional Equipment

Two expansion options connect directly to the control panel, and are automatically detected and supervised when the control panel is powered:

- FPD-7034 Four Point Expander
- D7039 Multiplex Expansion Module

When the control panel is powered after installing one of these options, the control panel displays one of the following windows:

4Z EXP DETECTED
PRESS ENTER KEY
MUX DETECTED
PRESS ENTER KEY

Press the [#/Enter] key to confirm the installation of the device and automatically set it up for supervision.

If the [#/Enter] key is not pressed during the power-up time-out period, the control panel resumes operation using the last confirmed status of the affected expander and displays an installation error condition.

 Expansion devices such as point expanders and multiplex expanders are disabled if they are removed from the control panel configuration after installation. You cannot disable supervision of these devices when they are installed.

Refer to the installation instructions for these expanders for additional information.

 When the D7039 Multiplex Expansion Module is first installed, the system displays an EEPROM fault. Execute the default procedure to synchronize the EEPROM on the expansion module to the EEPROM in the control panel. Remove power to the control panel, then reapply power and re-install option bus devices after the default procedure.

 Replacing a D7039 Multiplex Expansion Module causes the loss of programming of expansion points and PINs. Reprogram all multiplex point and PINs if you replace the D7039.

When the D7039 is first installed, or anytime the control panel is powered with a D7039 that has no points programmed, the system automatically starts the multiplex auto-programming process:

AUTO PROGRAM?
:YES(1)/NO(0)

Pressing the [1] key starts auto-programming, and pressing [0/Prog] allows the control panel to continue normal startup. The menu automatically closes with NO selected if no key is pressed after several minutes. Refer to *Section 5.9.4 Auto Program* on page 74 for detailed instructions on the auto-programming mode.

2.0 Control Panel Terminal Connections

Figure 5: FPD-7024 Control Panel Terminal Connections



Incorrect connections may result in damage to the unit and personal injury.



Before servicing this equipment, remove all power including the transformer, battery and phone lines.



Shared cable is not recommended for option bus, telephone or NAC wiring.

For connection to listed power limited Class 2 or Class 3 sources only.

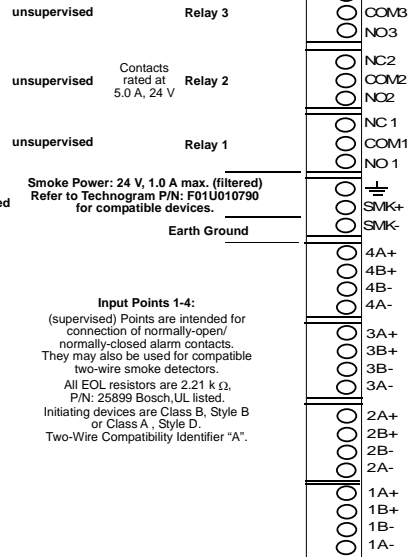

Typical Fire Wiring

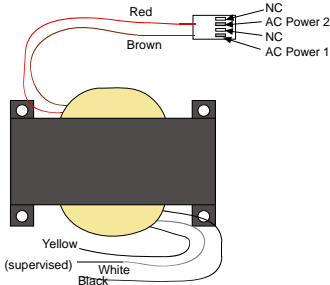
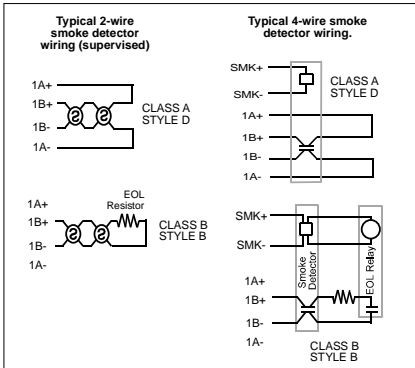

All wiring except battery terminal and primary AC power is power-limited. Primary AC and battery wires must be separated from other wires by at least 1/4 in. (6.4 mm) and tied to prevent movement.

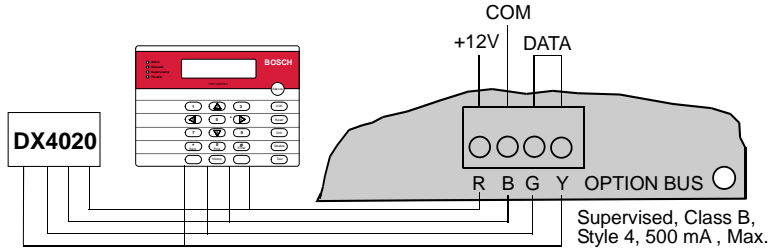
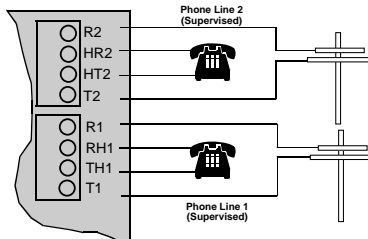

Supervised, Class B, Style 4, 500 mA, Max.

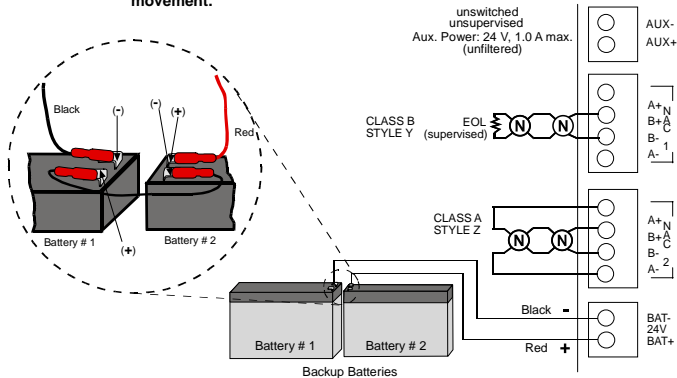

NOTIFICATION APPLIANCE CIRCUIT:	
NAC 1+	+24 V while in alarm; ground while in standby.
NAC 1-	Ground while in alarm; supervisory voltage while in standby.
NOTIFICATION APPLIANCE CIRCUIT:	
NAC 2+	+24 V while in alarm; ground while in standby.
NAC 2-	Ground while in alarm; supervisory voltage while in standby.
BATTERIES:	
BAT -	Requires two 12 V batteries, in series, for a combined voltage of 24 V. Charge current = 1.1 A, max.
BAT +	

Use only indicating devices as listed on Technogram P/N: F01U010791.



Do not short terminals - explosion and burn hazard.

2.1 Power Supply Connections

Use wire nuts to connect the primary side of the transformer (black and white wires) to the unswitched 120 V, 60 Hz or (yellow and white wires) to unswitched 240 V, 50 Hz circuit. Connect the earth ground to the threaded ground stud on the left side of the enclosure.



Place a wire nut over the unused black or yellow wire.

Figure 6: Connecting the Transformer to the FPD-7024 Circuit Board

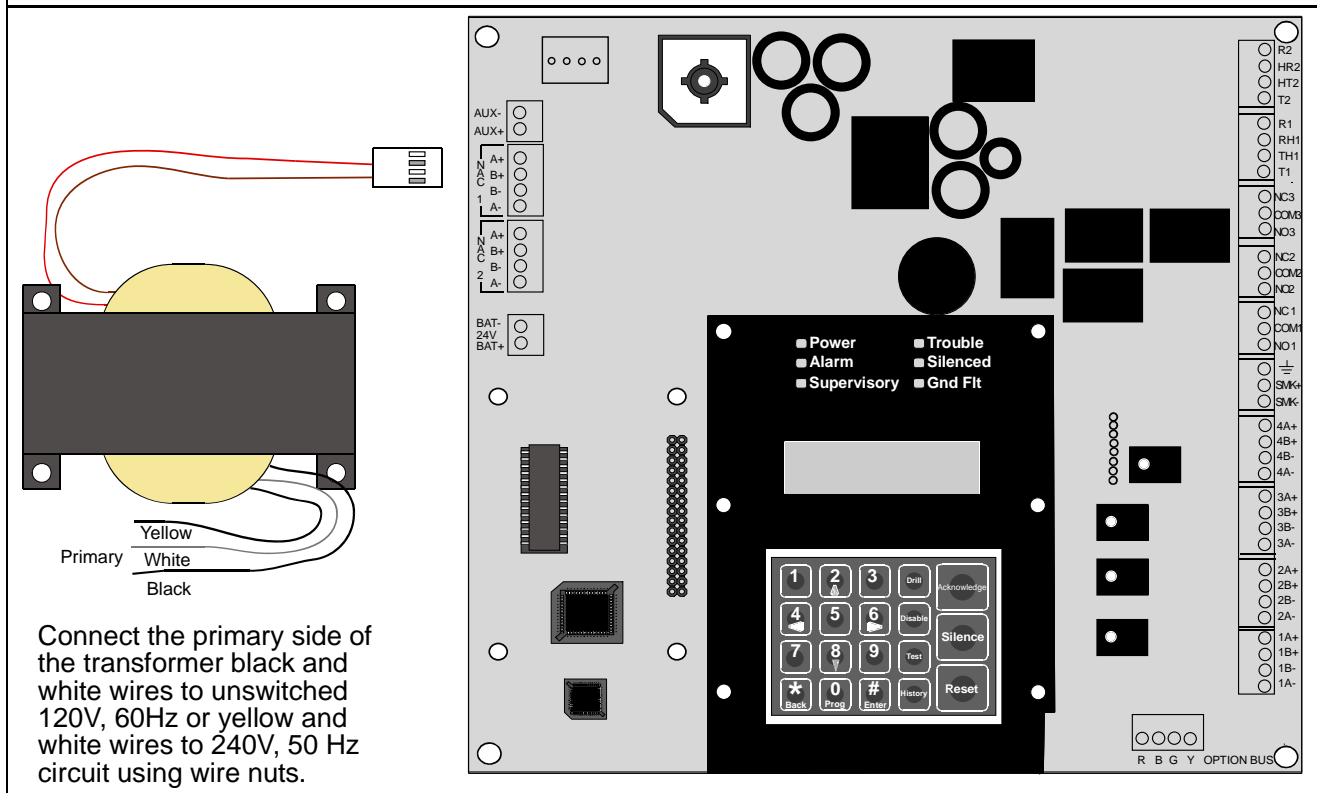

2.2 Option Bus Wiring Requirements

Use 18 AWG (1.2 mm) or larger wire to connect option bus devices to the FACP. The total length of wire connected to the option bus terminals must not exceed 4,000 ft (1,219 m), regardless of the wire gauge wire used.



Shared cable is not recommended for option bus, addressable points bus, telephone, or NAC wiring.



To comply with UL, do not share supplementary devices with primary device on the option bus.

Avoid shielded or twisted pair-wire except for special applications where a reduced length of wiring (approximately 50%) is acceptable for tolerating a harsh electrical environment.

The length of wire allowed between the control panel and the last device on a wiring run depends on the existing drawn on that wiring run. Reducing the number of devices on a wiring run allows the individual runs to be longer. Use the guidelines in *Table 10* on page 20 where devices are all of the same type on a given wire run.

Table 10: Option Bus Wiring Guidelines

Device Model Number	Wiring Run Number	Maximum Allowed Cable Length to Last Device (#18 Wire)	Current Draw (for reference)
D7030 LED Annunciator	1	1000 ft (304 m)	175 mA
D7030X LED Annunciator	2	500 ft (152 m)	175 mA x 2 = 350 mA
D7030 LED Annunciator	4	250 ft (76 m)	175 mA x 4 = 700 mA
FMR-7033 Remote Keypad	1	2000 ft (608 m)	100 mA
FMR-7033 Remote Keypad	2	1000 ft (304 m)	100 mA x 2 = 200 mA
FMR-7033 Remote Keypad	4	500 ft (152 m)	100 mA x 4 = 400 mA
D7048/B Octal Driver Module	1	500 ft (152 m)	330 mA
D7035/B Octal Remote Relay	2	250 ft (76 m)	330 mA x 2 = 660 mA
FPP-RNAC-8A-4C	2	4000 ft (1219 m)	< 50 mA each
DX4020 Network Interface Module	1	750 ft (229 m)	280 mA

Where more than one type of device is installed on a given wiring run, add together the alarm existing drawn by all the devices on the wiring run to determine the maximum allowed distance between the option bus terminals on the control panel and the last device on the wire run (the device farthest from the control panel).

Add up the total alarm load for option bus devices on the wire run, and use *Figure 7* to determine the maximum allowed length for the run. For example, if the total load of option bus devices on a particular run is 400 mA, the maximum length of the run can be up to 500 ft (152 m). No more than 4,000 ft (1,219 m) of wire can be connected to the option bus terminals, even if the individual lengths of the runs are all within limit.

Figure 7 shows allowed lengths for 18 AWG (1.2 mm). For 16 AWG (1.5 mm) wire, cable lengths can be 1.5 times longer. For 14 AWG (1.8 mm) wire, cable lengths can be 2.5 times longer. The 4,000 ft (1,219 m) maximum length of connected wire still applies.

Figure 7: Option Bus Cable Length vs Current Draw

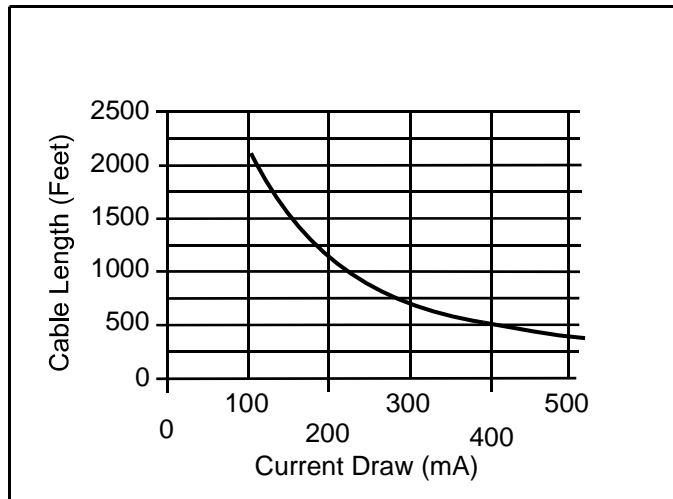

3.0 System Operation

3.1 Modes of Operation

There are four modes of system operation for the FPD-7024: Alarm, Supervisory, Trouble, and Normal.

3.1.1 Alarm

When an alarm occurs, the top line of the display shows ALARM (XXX), where XXX indicates the number of alarms. This display overrides any other system display. The second line of the display gives more instructions. When the group is entered by pushing the [6/▶] key, more details of the event appear. The top line shows the number of alarms and the point that is in alarm. The bottom line alternates between the instructions and the programmed description for the affected point. The built-in sounder turns on with a steady tone, and outputs programmed to activate with the existing alarm condition(s) activate.

When the control panel is not scanning the inputs, as during smoke power reset, alarm verification delay, or on-site programming, the trouble LED flashes to indicate this condition.

3.1.2 Supervisory

When a Supervisory condition occurs, Supervisory (XXX), XXX indicates the number of supervisory conditions. The second line of the display gives more instructions. When the group is entered by pushing the [6/▶] key, more details of the event appear. The bottom line alternates between the instructions and the programmed description for the affected point. The built-in sounder beeps. Outputs programmed to activate with the existing condition(s) then activate.

3.1.3 Trouble

When a trouble condition occurs (such as cut wiring for a point or AC power fails), the sounder beeps every 10 seconds. The Trouble LED lights and the LCD shows TROUBLE (XXX). When the [6/▶] key is pressed the group is entered and more detail appears. The system can diagnose and show a variety of trouble conditions, including those affecting the input points, NAC circuits, power, battery, system grounding, and internal operations of the fire control panel. Notify your installing company immediately if the system trouble message appears.

Press the [Silence] key to silence the system trouble beep.

3.1.4 Acknowledge

When the control panel is off-normal, the control panel's piezo (buzzer) can be silenced without silencing the NACs or resetting the control panel. Press the [ACK] button on the local or remote keypad to silence only the piezo.

3.1.5 Fire Silence/Reset



During a fire alarm, exit from the premises immediately. Do not enter the premises unless accompanied by the appropriate emergency services' personnel, or until they have given the OK to enter.

When it is determined that there is no fire, you can silence the horns or bells to allow more investigation of the devices that initiated the alarm, or you can reset the system to return it to normal operation.



Before using the [Reset] key, determine which smoke detector sounded the alarm so that the monitoring company can check that the system is operating correctly. If the control panel is being used as an addressable control panel, use the [History] key to determine which address is in alarm.

If the system is configured to allow alarm silencing, the [Silence] key turns off the horns or bells, but does not reset the alarm status and does not return the activated input to normal service. Detectors that were activated stay in alarm and can be checked (usually by observing an LED on the device) to see which detector caused the alarm. When the detectors causing the alarm are identified, reset the system to return it to normal service.

The [Reset] key clears the system alarm status, and briefly turns off power to the detectors to reset them. This command is required after any fire alarm affecting a point programmed for latching operation (which is the normal configuration). This operation is also required to reset a Class A, Style 6 multiplex (SLC) wiring fault troubles.

The software uses a system supervisor function that automatically supervises the system software for proper operation. If the system fails, a CPU FAULT message appears, and the nature of the failure can be optionally recorded in the history buffer. To enable history buffer recording for CPU faults, program Output Zone D of onboard Relay 2 to Zone 51 (unused). The history buffer message, if enabled, shows CPUFLTxxx, where xxx is an error code. If the display shows CPU FAULT, contact Bosch Security Systems, Inc. Technical Support and report the history buffer code along with a description of the operations that caused the fault. Unusual conditions during programming and debugging operations can result in a CPUFLT message in the history buffer. If, this occurs when the control panel is in service, report it to Technical Service.

3.1.6 Off-Normal Displays

Control panel alarms and problems are indicated by one of the messages shown in *Table 11* on the top line of the display. Contact your installing company if problems persist.

Table 11: Off-Normal Displays

Off-Normal Display	Description
FIRE ALARM (XXX)	One or more fire or waterflow points are in alarm.
SUPERVISORY (XXX)	One or more supervisory conditions exist.
TROUBLE (XXX)	A trouble condition exists (AC power failure, phone line trouble, and so on.).

3.1.7 Normal

When the system operates normally, it shows SYSTEM NORMAL on the top line of the display, the Power LED lights steadily, and no other LEDs are lit. The bottom line indicates the existing date MM/DD/YY and time HH:MM. If the system is programmed to require a PIN, the second line of the LCD screen shows ENTER PIN.

3.2 Basic System Use

3.2.1 Function Keys

A keypad that does not require a PIN number shows (under normal conditions) SYSTEM NORMAL on the top line, and existing date and time on the bottom line. On a keypad that does require a PIN number, enter the PIN number first. This enables the function keys.

3.2.2 Selecting Menu Items

Depending on which level in the system, (menu, sub-menu, sub-sub-menu), you can select an item three different ways:

1. In the main menu, TEST, HISTORY, DISABLE, and DRILL each have an exclusive key on the keypad. To select one of these menu items,

- press the corresponding key. For example, to select TEST, press the [TEST] button.
- 2. The [PROG] and [ENTER] keys are not exclusive, but shared with other characters. The character sharing the corresponding key appears in the second line following a forward slash (/). To select one of these items, press the corresponding key. For example, the [PROG] key is also 0.
- 3. The key corresponding to a sub-menu item might appear in the second line preceding a dash. Press the corresponding key to select that item. For example, press [1] to select PROG TIMES.

While a menu is active, you do not need to wait for the desired menu item to appear before making your selection. You can select any item on the existing menu rotation at any time.

3.2.3 After a Main Menu Item is Selected

When a main menu item is selected, the keypad might prompt you to enter your PIN. If so, enter the number (factory default is 9876) and press the [#/Enter] key (or press the key labeled with the desired command directly). The display automatically retrieves the sub-menu display.

3.2.4 Returning to an Earlier Screen

To return to a previous screen at any time, press the [*/Back] key. To return to the SYSTEM NORMAL display, press the [*/Back] repeatedly until you reach SYSTEM NORMAL. When you reach SYSTEM NORMAL, you cannot go any farther.

3.2.5 Entering Data

When a sub-menu item asks you to enter data, enter the data and press the [#/Enter] key. If data already exists at a particular location, you can either accept that data or enter new data.

When you press the [#/Enter] key to enter the data, the display returns you to the previous sub-menu display.

3.2.6 Drill

The drill command activates all NACs and no relays. It creates a history log entry and as an option can be reported to the central station.

3.2.7 Disable

Use the disable command to disable input points, outputs, or the dialer. When any device is disabled, the system shows this condition on the LCD and on the system trouble LED. The Disable All Inputs operation takes several seconds to perform, during which time the system display remains fixed.

3.2.8 History



If a system without a D7039 Multiplex Expansion Module loses all power (AC and standby battery), all history events are cleared.

The HISTORY option is a chronological list of system events that occurred. Press the [History] key to HISTORY select from the Main Menu (SYSTEM NORMAL display).

On an FPD-7024 FACP with a D7039 Multiplex Expansion Module, up to 499 History events are supported.

On an FPD-7024 FACP without a D7039 Multiplex Expansion Module, up to 99 History events are supported.

After you press the [History] key, the most recent system event appears on the top line of the LCD with the time and date below it.

Example: (Assume you pressed the [History] key at the Main Menu):

While the first event shows, the bottom line toggles every four seconds between the time and date that the event occurred.

To return to a previous screen in the history buffer, press [2/▲]. To scroll to the next event record, press [8/▼]. The abbreviations shown in *Table 12* on page 8 are used in history events.

Table 12: History Event Abbreviations

Abbreviation	Meaning	Abbreviation	Meaning
ALRM	Alarm	OFFNORM	Off Normal at Test
ARST	Alarm Restore	PH1	Phone Line 1
AUTOTST	Auto Test	PH2	Phone Line 2
BATT:LOW	Battery Low	RSTR	Restore
BAT:RSTR	Battery Restore	S	Supervisory
CPUFLT	Internal Error	SMK:FLT	Smoke Power Fault
DBL	Disable	SYSRESET	System Reset
DRILL:BEG	Drill Begin	YSRST	System Restore
DRILL:OVR	Drill Over	SYSTRB	System Trouble
DRST	Dirty Restore	SYS:WDOG	Automatic CPU Reset (Watchdog)
DRTY	Dirty	TRBL	Trouble
DSBL	Disable	TRST	Trouble Restore
EE2	EEPROM	TST:BEG	Test Begin
ENBL	Enable	TST:OVR	Test Over
F	Fire	W	Waterflow
MANULTST	Manual Test		

Refer to *Appendix C* on page 86 for additional history log ID information.

3.3 Keypads

3.3.1 Built-in Keypad

The keypad built into the control/communicator is an alphanumeric LCD keypad. It has a two-line by 16-character display to provide information on various control panel functions. Usually, the first line shows the off-normal condition, while the second line describes specific details that might be relevant to the existing system status. A built-in sounder annunciates keystroke entries and acts as a warning device.

Figure 8: Built in Keypad

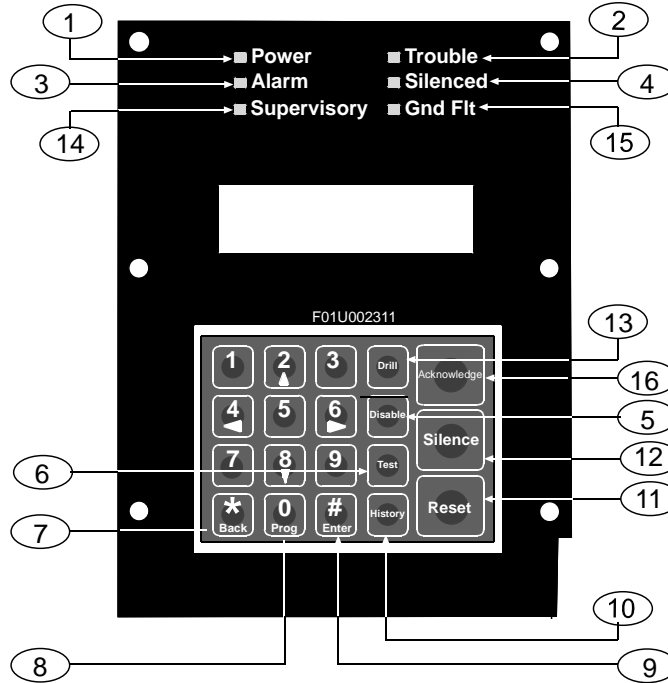

- | | |
|---|--|
| <ol style="list-style-type: none"> 1. Green Power LED - is on when the AC power is present, and flashes when the unit is operating from battery power. 2. Yellow Trouble LED - lights when the system detects a problem with wiring or internal circuitry. The Trouble LED flashes while programming mode is active and whenever inputs are not active, such as during smoke power reset or alarm verification. 3. Red Alarm LED - lights when the system registers an alarm and was not reset. 4. Yellow Silenced LED - lights when the user manually silences an alarm or trouble condition, turns off when the condition that was silenced is corrected. 5. [Disable] key - used to disable or re-enable inputs, NACs or relays (outputs), and the dialer. 6. [Test] key - used to select one of seven special test modes (refer to Section 3.4 Testing on page 26). 7. [*Back] key - used during programming to exit from menus or to exit from the programming mode entirely. | <ol style="list-style-type: none"> 8. [0/Prog] key - for selecting the programming mode. 9. [#Enter] key - to accept data when in the programming mode. 10. [History] key - to view system events. 11. [Reset] key - briefly (programmable from 1 to 16 seconds) turns off power to the detectors to reset them and clears any off-normal conditions. 12. [Silence] key - quiets the bell or sirens for an alarm or trouble condition, if the system is so configured. 13. [Drill] key - used to activate the NACs manually. It creates a history log entry and as an option reports to the central station. 14. Yellow Supervisory LED - lights whenever the system registers a supervisory condition. 15. Yellow GND Fault LED - lights whenever the system detects a ground fault condition. 16. [Acknowledge] key to silence local keypad sounders and to view off-normal conditions. |
|---|--|

For abbreviations on the keypad and control panel, refer to Appendix A on page 84.

3.3.2 FMR-7033 Keypad

The FMR-7033 Keypad is an alphanumeric LCD keypad. Up to four of these keypads can be mounted apart from the main control panel to provide additional locations for system status and control. The LCD display and keys operate identically to those of the built-in keypad on the control panel (refer to *Appendix A* on page 84).

Figure 9: FMR-7033 Keypad

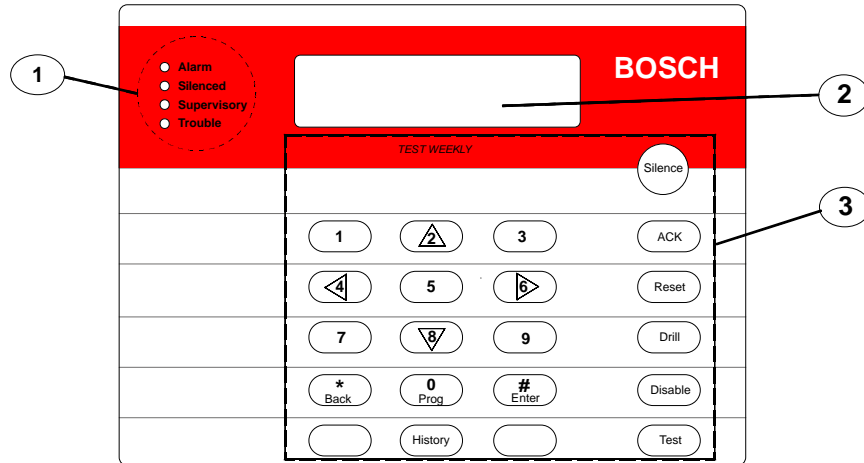

- 1 -LEDs
- 2 -Keypad Display
- 3 -Keys

3.4 Testing

Select any of seven special test modes using the [Test] key on the built-in and FMR-7033 keypads.

3.4.1 Walk Test

The Walk Test allows a technician to alarm each point manually to ensure that detectors connected to a point send an Alarm report to the control panel. While in this mode, the LCD shows the system test status and the trouble sounder sounds every 10 sec. Outputs programmed for general alarm or fire alarm output, or outputs mapped to points using zones activate during this test as points are alarmed and restored:

When selecting this mode, three options are given for activation of outputs:

- SHORT ACTIVE: 1 second activation
- LONG ACTIVE: 5 second activation
- NO ACTIVE: outputs do not activate

As each point is alarmed, the outputs activate once (if selected) and power is reset. As each point is activated, alarms and restorals are logged in the control panel’s history log. When the point returns to standby, the outputs activate twice. The control panel attempts to reset points ten times to restore them. Points remaining alarmed when exiting from the walk test mode cause an immediate alarm.

3.4.2 Communicator Test

The communicator sends a test report. While communication is in progress, the Power LED flashes. When the communication succeeds, a long keypad beep sounds, the Power LED returns to normal, and the display returns to normal.



This test is available only if your system sends alarms and system information to a monitoring service, and was programmed by the security installing company to permit communicator tests.



Terminating the communicator test function (with the [*]/Back] key) resets the communicator and discards all unsent reports. When an off-normal condition occurs during a Communicator test, the test automatically resets, clearing all reports, so the off-normal conditions are sent normally.

3.4.3 Call for Remote Programming

Phone Numbers 1 and 3 must be programmed, along with Account Code 1. The control panel calls Phone Number 3 and attempts to connect for downloading. If the control panel is already using the phone line, it sounds the three-beep error tone. This function requires an access code with programming authority (Level 1).

3.4.4 Test Battery/NAC Circuits

If a power failure occurs, your control panel has a built-in battery that continues to power the system for several hours. The control panel automatically recharges the battery when power is restored. In this test mode, the system operates the local NAC circuits and tests the battery for two seconds. The test results are shown at the end of the test, and are not reported to the central station. Pressing the [*]/Back] key or the [#]/Enter] key returns the display to standby mode, or the unit times out after three minutes.

3.4.5 Answer for Remote Programming

The control panel immediately seizes the phone line to answer a remote programming call. While programming is underway, the Trouble LED flashes. This also allows on-site PC downloading. If the control panel already uses the phone line for a report communication, it sounds the three-beep error tone. This function requires an access code with programming authority (Level 1).

3.4.6 Manually Activate Outputs

This test turns a selected output on and off manually.

3.4.7 Read Zone Input Levels

This test shows the status of a selected on-board point. The loop existing through the point is shown.

Normal loops show 11 to 15 mA. Loops in alarm show over 25 mA, and loops in trouble show less than 6 mA.

3.4.8 Addressable Point Test (MUX Test)

This test allows activation of the special test mode for addressable (multiplex) devices. This applies only if the optional D7039 Addressable Point Bus Expander module is installed.

When this test mode is selected, the system asks which bus to test, 1 or 2. Select 1 to test points 9 to 128 and select 2 to test points 129 to 255. The system presents 5 options:

- **List Devices:** Shows the point numbers of all devices on the selected bus. Some devices (such as a dual point module) can use two or more points
- **Show Holes:** Lists locations on the bus that have no assigned device. This can help to find programming errors or identify an available address for a new device.
- **Show Extras:** The system scans the bus to identify devices that are present on the bus, but are not programmed into the system. Scanning the bus takes about 60 sec to scan the bus. Restoring the bus after scanning also takes about 60 sec. The system cannot identify devices above Address 128 on Bus 1, or below Address 129 on Bus 2. If you know that a device is connected to the system but cannot find it, ensure that it is connected to the correct bus: 9 to 128 for Bus 1, 129 to 255 for Bus 2.
- **Show Missing:** Lists devices programmed into the system but not present on the bus are listed. Unless a device was programmed into the system (such as using MUX EDIT), it is not considered missing.
- **Show Status:** After you select a device and press [#]/Enter], this test shows detailed status information for the selected device. Eight conditions (not all status conditions apply to or are supported by all devices) are shown. See the display shown below (which updates automatically every five seconds). For this option, you can view the status of any MUX device regardless of which bus you selected to test when test mode was entered.

XxLxRx DxMxTx FxAx

x is either 0 or 1 depending on whether the condition is false or true (0=false and 1=true). The letters indicate the condition:

- X: Reserved for future use.
- L: Commanded relay state - this is how the output relay should be set.
- R: Actual relay state - this is how the output relay is actually set.
- D: Detector dirty - the detector is excessively sensitive.

- M: Missing device - the device cannot be found on the loop. Unless a device was programmed into the system (such as using MUX EDIT), it is not considered missing.
- T: Tamper – the detector’s case was opened.
- F: Loop fault - the loop from a contact input device is open, or the device is faulted.
- A: Loop alarm - the point is in alarm.

Pressing [*/Back] ends the display for any of these modes.

Examples: X0L0R0D0M0T0F0A0 (relay off, not dirty, not missing, no tamper, no fault and no alarm).

3.4.9 Sensitivity Test

Tests the mux smoke detectors to determine if they are within their normal range of sensitivity. Press [Test] then [9].

3.5 Point/Zone Mapping

The control panel supports a flexible system to map input points to output points. The system defaults so that all NAC outputs are activated by a fire alarm. By programming output zones, you can create almost any output activation scheme, such as “floor above and floor below” activation or conditional elevator recall.

Input points: Smoke detectors, pull stations, and so on.

Zone: A group of input points (Zones 1 to 50 are configurable, 52 to 63 are activated automatically).

Output points: NACs (notification appliance circuits) such as bells, strobes, and relays.

Inputs activate zones, and zones activate outputs.

Zones 1 to 50 are available for the installer to program. Each input can activate one zone; however, any number of inputs can be mapped to the same zone.

Zones above 50 are automatically activated by inputs. For example, any input that is configured as a waterflow type activates Zone 61 when it is alarmed. Any output driven by Zone 61 activates when any waterflow type point is alarmed.

Refer to *Figure 10* to show how inputs control zones and zones control outputs.

Figure 10: Mapping, Inputs, Zones, and Outputs

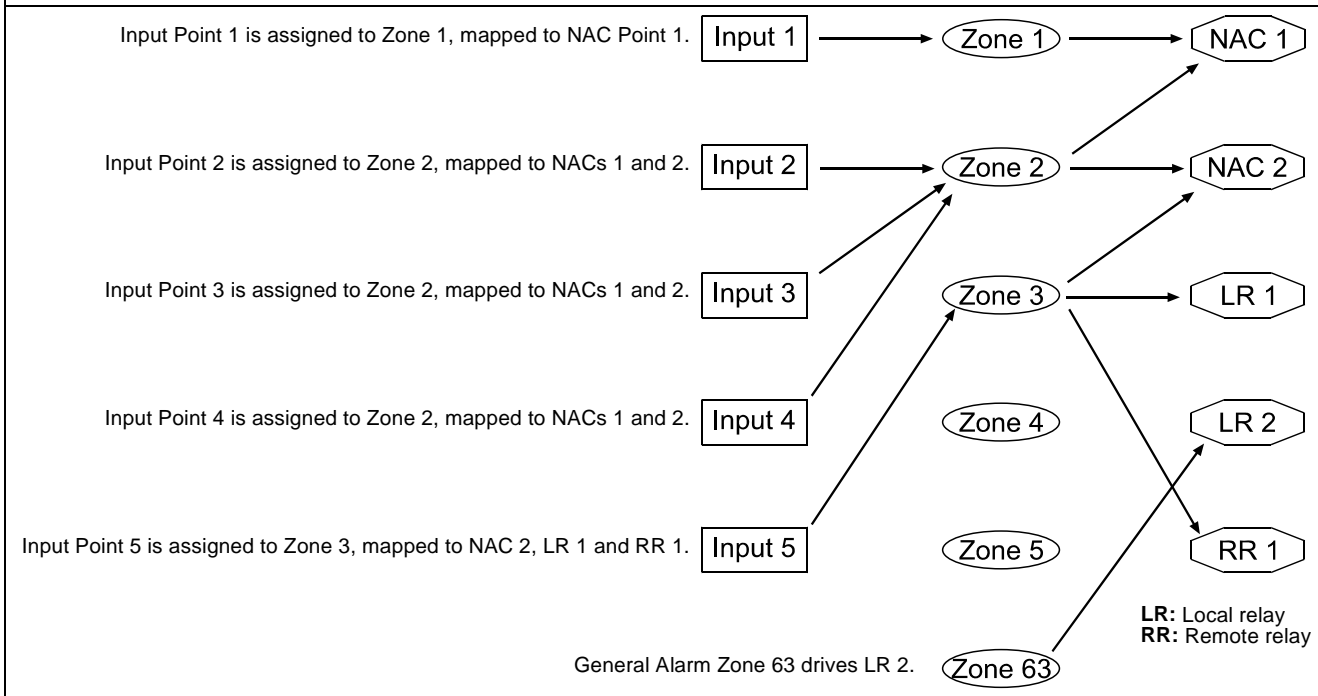

Up to 64 zones can be assigned. The installer can assign Zones 1 to 50. Zones 51 to 63 are hard-coded to pre-assigned conditions. Refer to *Table 13*.

Table 13: Pre-Assigned Zones

Zone	Pre-Assigned Condition
51	Reserved for future use.
52	General Fire Alarm, Waterflow (non-silenceable). Same as Zone 53, but remains active even while system is silenced.
53	General Fire Alarm (silenceable). Active when a fire alarm condition is present; does not activate for waterflow.
54	Activates for approximately 7 sec before dialing, to initiate dial tone on a ground start phone system.
55	General Supervisory (silenceable)
56	General Waterflow (silenceable)
57	Communication Trouble. Active when the dialer fails to communicate; remains active until communication through the digital communicator is restored.
58	General Supervisory Alarm (non-silenceable). Active when any supervisory alarm condition is present.
59	Alarm Verification. Active while alarm verification is in progress. This starts with the first detection of an alarm to be verified and clears in two minutes, or when system is reset.
60	No AC. Active when AC power fails.
61	General Waterflow (Non-silenceable). Active when any waterflow alarm is present.
62	General Trouble. Active while any system trouble is present, not active in test and programming modes.
63	General Alarm, Waterflow (non-silenceable). Active while any alarm, including supervisory, is present. Remains active even while system is silenced.

3.6 Personal Identification Numbers

The personal identification number (PIN) is the four digit code users enter at the keypad to gain access to the system. A PIN can be assigned to each User Number. The User Number identifies each person using the system. There are 16 possible User Numbers (00 to 15). User codes 00 to 99 are available with the installation of a D7039 Multiple Expansion Module. The Authority Level assigned to each User Number determines which functions each user can perform.

Your system can have up to 100 different PINs, each four digits long. There is one PIN for each User Number. Attempting to assign the same PIN to multiple User Numbers results in the three-beep error tone, and the change is not made.

User Number 00 is designated as a Programmer's Code. It can be used to silence alarms, reset, disable, and program the unit.



User Number 00 is shipped from the factory with the sequence of 9876. Change this code to one of your personal preference. It is automatically assigned the highest authority. Never program PINs with common sequences such as 1111, 1234, or 2468 because they are easily violated.

Authority levels are assigned to PINs to determine which functions each user can perform. *Table 14* describes the four authority levels.

Table 14: PIN Authority Levels	
PIN Authority Level	Allowed Operations
Maximum (1)	All control panel operations, including programming, and disable
Medium (2)	System test modes, fire drill, reset, silence, view history
Minimum (3)	Silence, view history
None (0)	None

3.7 Communicator Operation

The FPD-7024 contains an integrated communicator that can be optionally enabled to send reports to a monitoring station. When enabled, operation of the communicator is fully automatic.

-  You must enable and configure the communicator before it works. The communicator and phone line monitors are disabled in the default factory configuration.
-  To disable a phone number, set the FORMAT to 0=disable. To completely disable the communicator, set FORMAT to 0=disable for both phone numbers, and set MONITOR to 0=NO for both phone lines.
-  Do not install this control panel on a phone line that might be required for other emergency use.

When events occur, the communicator sends them to the monitoring station in priority order according to NFPA requirements. Fire and waterflow alarms are sent first, followed by supervisory alarms and trouble reports and then all other reports. Priority reporting can send a Restoral report after several alarm reports in a situation where a point sends multiple alarms, implying that a point is restored when it has returned to alarm. The following sequence, (alarm, restore, alarm) is sent as (alarm, alarm, restore) when priority sorting is applied.

 Priority sorting on events sent to a monitoring station can cause the message sequence to imply that a point is restored when it is not.

The communicator can store 32 events while waiting for the monitoring station to accept the events. If more than 32 reportable events occur before the monitoring station accepts events, some event information is lost and a Data Lost report is sent to the central station.

The FPD-7024's communicator is equipped with a line seizure relay to prevent interference with outgoing event reports. In a system where the fire communicator shares the phone line with other equipment on the premises, the phone line might be unavailable to the other equipment for up to 15 min has a fault with the central station acceptance of the event data. Phone lines for fire control panels must not be shared with other equipment.

4.0 Programming

 After any programming change, and especially after remote programming changes, completely check the operation of the control panel. Hazards to life and property can result if the system is not tested to detect possible improper programming.

 When programming the system, enter only valid types of information within the ranges specified in the programming table. Incorrect programming results in improper system operation. When using built-in programming, invalid input values might not be rejected in every case. Ensure that you enter only the intended values while programming to prevent improper system operation

4.1 Programming Features

Table 15: Programming Features for UL864

Program Feature or Option	Permitted in UL864 (Yes/No)	Possible Settings	Settings Permitted in UL864
Auto Test Frequency	Yes	1) 4 HOURS 2) 12 HOURS 3) 24 HOURS 4) 7 DAYS 5) 28 DAYS 6) Disabled	1) 4 HOURS 2) 12 HOURS 3) 24 HOURS
Program Relay	Yes	1) Release on Trouble 2) Activate on Ground Start	1) Release on Trouble
AC Fail Delay	Yes	1) Wait for DC 2) Wait Delay Time 0-24 HRS	2) Wait Delay Time 1-3 HRS
Phone Line Monitor for Each Line	Yes	0) No 1) Yes	1) Yes
Remote Programming (offsite)	Yes	1) PHONE #1 2) PHONE #2 3) COMPTR PHONE	1) Phone #1 2) Phone #2
Response Time	Yes	1) Fast (.5 sec) 2) Programmed	2) 1 sec
NAC Config	Yes	1) Steady 2) Pulsing 3) California March 4) Temporal 5) Wheelock 6) Gentex 7) System Sensor	1) Steady 2) Pulsed 3) California March 4) Temporal 5) Wheelock 7) System Sensor
Alarm/Trouble Open Status	Yes	1) Alarm 2) Trouble	2) Trouble
Latching	Yes	1) Yes 2) No	1) Yes for Alarms
Heartbeat Interval	Yes	001 - 255	001 - 090
Ring Count	Yes	00 - 15	00
PIN Required on Remote Keypad	Yes	0) No 1) Yes	1) Yes

4.2 Point Programming

Each of the points in the system can be programmed with its own characteristics. Point functions simplify the programming of points by allowing you to define a common set of characteristics for similar points, and assigning those characteristics to selected points as a point function. There are 16 point functions, each of which has programmable features for configuration (fire, waterflow, and so on), local only operation, silencing, and loop response. Each point is assigned to use the characteristics of one point function (*Table 16*), and then is individually programmed for additional characteristics: response to an open circuit, enabled status, output zone, verification, latching and point description.

Before programming the control panel, determine the types of functions that are needed, and then map the various input points to the functions.

For example, you might determine that you have the following functions:

Refer to *Table 16* for the characteristics that correlate with each function.

- 1 = Pull Station
- 2 = Smoke Detector
- 3 = Reset Keyswitch
- 4 = Silence Keyswitch
- 5 = Supervisory Input
- 6 = Local Test
- 7 = Waterflow Sensor



Refer to *Appendix D* on page 93 for default point function information.

Table 16: Point Function Characteristics

Function	Configuration	Local Only?	Silenceable?	Loop Response
1. Pull Station	Fire	No	No	Fast
2. Smoke Detector	Fire	No	No	Fast
3. Reset Keyswitch	Reset	Yes	No	Fast
4. Silence Keyswitch	Silence	Yes	No	Fast
5. Supervisory Input	Supervisory	No	Yes	Fast
6. Local Test	Fire	Yes	Yes	Fast
7. Waterflow Sensor	Waterflow	No	No	Programmed

4.3 Alpha Programming

When programming the point descriptions, the numeric keys are used to enter alphanumeric information similar to the way telephone keys are used to process information over the phone lines each key represents four or more letters or symbols. Refer to *Table 17*.



A different character is entered each time a numeric key is pressed. For example, pressing [2/▲] repeatedly enters A, B, C, 2, A, B, and so on.

Table 17: Programming the Points Using the Alphanumeric

Key	Values								
	SPACE	1	,	'	&	/	#	!	⁻¹
	A		B		C		2 ²		
	D		E		F		3 ²		
	G		H		I		4 ²		
	J		K		L		5 ²		
	M		N		O		6 ²		
	P		R		S		7 ²		
	T		U		V		8 ²		
	W		X		Y		9 ²		
	Q		Z		0				
	Enters the description and returns to the programming menu.								
	Returns to the programming menu without entering changes.								
	Moves the cursor one space to the right.								
	Moves the cursor one space to the left.								

¹ Press [1] nine times to reach this value.

² Press the listed key four times to reach this value.

Figure 11: Essential Keys for Alpha Programming

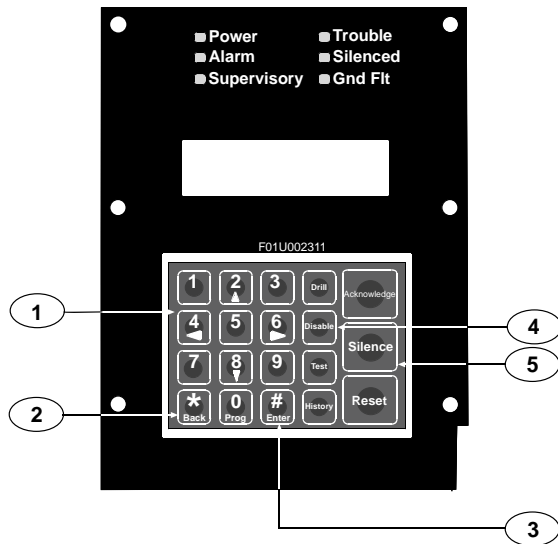

- 1 - Number keys (including 0) - used to enter alphanumeric values.
- 2 - [* / Back] key - used to exit alpha programming, or exit the programming mode entirely.
- 3 - [# / Enter] key - used to accept data when in programming mode.
- 4 - [Disable] key - moves the cursor one space to the left.
- 5 - [Silence] key - moves the cursor one space to the right.

4.4 Format Programming

4.4.1 4/2

When 4/2 Format is used, reports generated by points consist of an event type (first digit) and a point number (second digit). Digits can be programmed for the following events: fire alarm, fire restoral, waterflow alarm, supervisory alarm, point trouble, trouble restore, point disable, disable restoral, and monitor alarm. The same event type (first digit) is sent for any point. The point number is the second digit. Each point can be programmed to a different digit. This programming is done under 7- PROG FORMATS, 1- 4/2 POINT RPT.

Additionally, 18 system events can each be programmed with a unique two-digit code. Events that can be programmed this way include, for example: System Silence, Fire Drill, Phone 1 Trouble, and Phone 2 Restoral. This programming is done under

7- PROG FORMATS, 2- 4/2 RPT CODS.

The 4/2 (and 3/1) format cannot report full point data for each point. Points 1 to 10 have unique reporting codes. The codes repeat every ten points. For example, Point 31 has the same point report as Points 11 and 21.

4.4.2 BFSK

Similar to the programming of system events for 4/2 Formats, five system events can be programmed for two unique digits each when the BFSK format is used. This programming is done under 7- PROG FORMATS, 3- BFSK RPT CODS.

The BFSK format supports only a three-digit account number. The control panel sends the first three digits that are programmed. The BFSK (and tone burst) format requires that an A (hex character) be entered at the control panel to cause the receiver to display 0. The BFSK format can report only eight points, so points 8 to 255 are all reported as point "8".

4.4.3 SIA

The report sent by the SIA format when the control panel is silenced can be programmed. By default, the control panel sends KB when it is silenced. You can program letters to be sent for this condition by entering the hexadecimal ASCII code. All other SIA reports are fixed, and do not require programming.

4.4.4 Contact ID

The Contact ID reports are fixed and do not require programming.

4.4.5 3/1

The 3/1 reporting codes are determined by the programming of the 4/2 codes. Send only Digit 1 (left digit of the two-digit code) and the first three digits of the account number.

4.4.6 Modem IIIa²

The Modem IIIa² reports are fixed and do not require programming.

4.5 Program Menu Tree

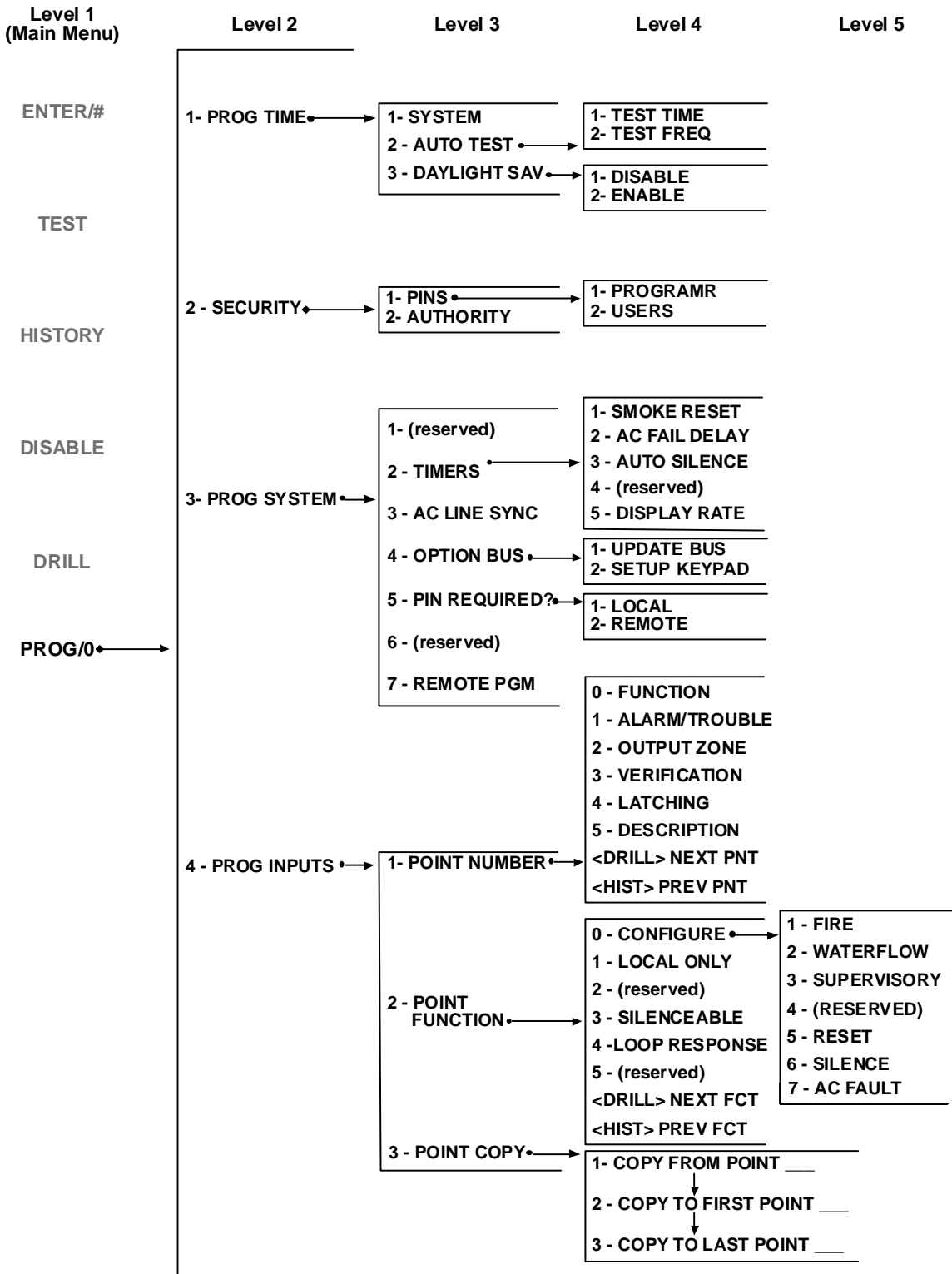

NOTE: Refer to *Appendix D* starting on page 93 for factory defaults.

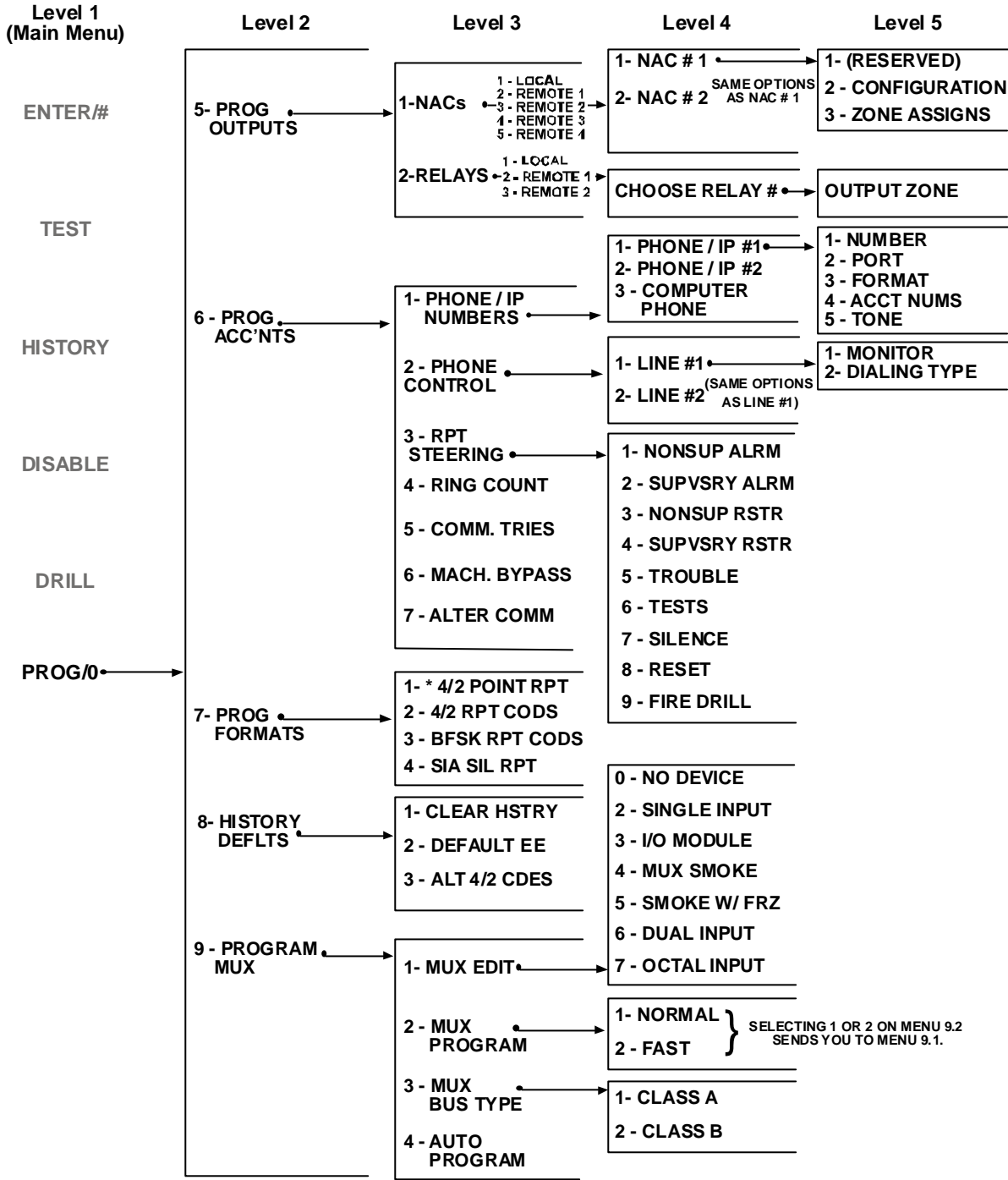

NOTE: Refer to *Appendix D* starting on page 93 for factory defaults.

4.6 Shortcuts

You can use shortcuts to reduce repetition and provide speedy instructions for programming the control panel.

The first level in the system is the Main Menu. For all system programming, <PROG/0> is your Main Menu choice. Therefore, the first number in the shortcut is “0”.

The second level in your system provides eight options: PROG TIME, SECURITY, PROG SYSTEM, PROG INPUTS, PROG OUTPUTS, PROG ACCOUNTS, PROG FORMATS, and HISTORY DEFAULTS. When the D7039 MUX Expander is installed, a ninth option appears: PROGRAM MUX. The second number in the shortcut enters the Level 2 option and allows access to Level 3.

Level 3 provides the third set of options that branch from Level 2 (*Figure 12*). The third number in the shortcut represents the option chosen in Level 3.

Figure 12 is an example of the shortcut to TEST FREQ and TEST TIME. The sample of the Program Menu Tree shows that to get to TEST TIME and TEST FREQ, you must go to PROG/0 in Level 1, PROG TIME in Level 2, and AUTO TEST in Level 3. The shortcut is simply a list of the keys you press to get to the fourth level option. Once you enter the shortcut, follow the procedural description that appears on the screen of the specific function you are programming.

Figure 12: Example of a Programming Shortcut

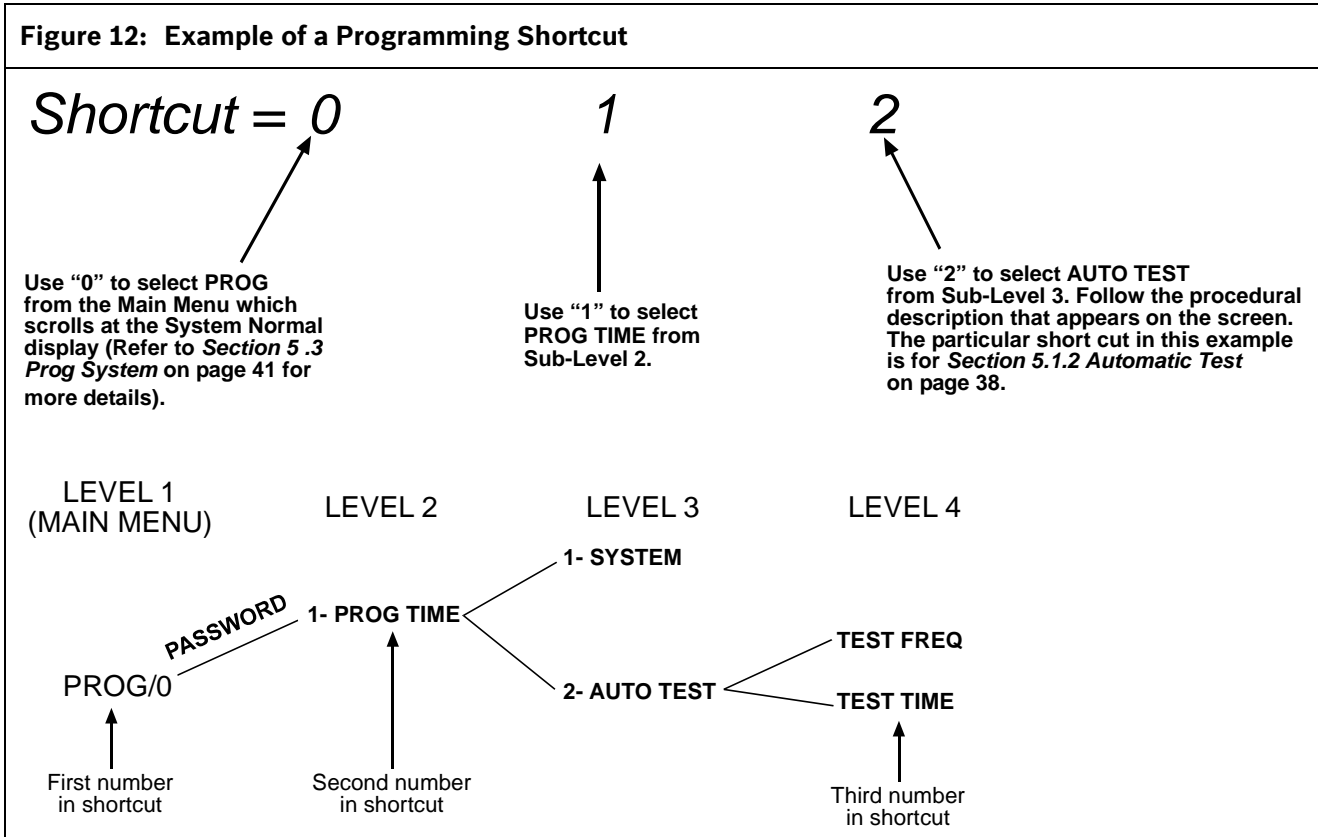

4.7 Remote Programming

The system operates during remote programming so that new alarms end the remote programming session and report normally. Using the keypads to perform other functions during remote programming (such as tests and disables) can cause remote programming to disconnect or other unexpected operations. Avoid downloading programming changes that cause alarms, because the session disconnects as soon as the alarm occurs, before the session completes. To indicate that the system is in a special operating mode with user input inhibited (but alarm monitoring continuing), the system indicates SYSTEM TROUBLE, RMT PRG ACTIVE during remote programming. Sounders do not activate during this mode, but other outputs programmed for Zone 62, general system trouble, do activate.

Trouble conditions that occur during a remote programming session are not annunciated at the control panel until the remote programming session ends. These conditions are available in the remote programmer diagnostic displays during the session. Alarm conditions terminate remote programming and are shown immediately.

When remote programming is disabled, you can still connect to the control panel for diagnostics and view the existing programming (except PIN numbers). To actually change programming, enable remote programming.

To enable remote programming, refer to the following programming items:

- 0-3-7 Remote Programming (*Section 5.3.5 Remote Programming* on page 47)
- 0-6-1 Computer Phone (*Section 5.6.1 Phone Numbers/IP Addresses* on page 58)
- 0-6-1 Account Number 1 (*Account Numbers* on page 62)
- 0-6-2 Dialing Type (*Dialing Type* on page 64)
- 0-6-4 Ring Count (*Section 5.6.4 Ring Count* on page 66).
- 0-6-6 Machine Bypass (*Section 5.6.6 Machine Bypass* on page 66)

An access code with maximum authority (1) is needed to begin remote programming from the panel.

5.0 Control Panel Programming

Main Menu:

```
SYSTEM NORMAL
SELECT: PROG/0
SELECT: ENTER/#
SELECT: TEST
SELECT: HISTORY
SELECT: DISABLE
SELECT: DRILL
```

Programming Menu:

```
PROG/0
```

```
1- PROG TIME
2- SECURITY
3- PROG SYSTEM
4- PROG INPUTS
5- PROG OUTPUTS
6- PROG ACC'NTS
7- PROG FORMATS
8- HISTORY DEFLTS
9- PROGRAM MUX
```

5.1 PROG TIME

```
PROG TIME
```

```
1- SYSTEM
2- AUTO TEST
3- DAYLIGHT SAV
```

5.1.1 Program Time



Shortcut: 0-PROG, 1-PROG TIME, 1-SYSTEM

The following window appears:

```
ENTER DATE
MMDDYY:_____
```

Enter the date followed by the [# / Enter] key. The following window appears:

```
ENTER TIME
HHMM:_____
```

Enter the time followed by the [# / Enter] key.

5.1.2 Automatic Test

Test Time



Shortcut: 0-PROG, 1-PROG TIME, 2-AUTO TEST

Use this feature to program the time of day at which automatic tests occur. This feature uses a 24-hour clock (for example, 11:00 p.m. = 2300).

The following window appears:

```
AUTOMATIC TEST
1- TEST TIME
2- TEST FREQNCY
```

Press [1] to select Test Time. The following window appears:

```
AUTO TEST TIME
HHMM:_____
```

Enter the time followed by the [# / Enter] key.

Test Frequency



Shortcut: 0-PROG, 1-PROG TIME, 2-AUTO TEST

This feature allows you to program how often the automatic test reports are sent. The first test is sent when the programmed test time matches the system time. Subsequent reports are sent according to the selected interval.

The following window appears:

```
AUTOMATIC TEST
1- TEST TIME
2- TEST FREQNCY
```

Press [2/▲] to select Test Frequency. The following window appears:

```
AUTO FRQNCY (__)
1- 4 HOURS
2- 12 HOURS
3- 24 HOURS
4- 7 DAYS*
5- 28 DAYS*
```

* Refer to *Table 15* on page 32.

Press the number key that corresponds to your selection. The existing setting is displayed in parentheses on the first line. After you have programmed the test frequency, the previous window appears.

5.1.3 Daylight Saving Time



Shortcut: 0-PROG, 1-PROG TIME, 3-DAYLIGHT SAV

This feature enables automatic adjustment of system time for Daylight Saving Time. The dates for the adjustment are pre-programmed in the system.

The following window appears:

```
DAYLIGHT SAV
1- DISABLE
2- ENABLE
```

Press [1] to select DISABLE or to select [2/▲] to ENABLE. After you have programmed this feature, the previous window appears.

5.2 SECURITY

```
SECURITY
1- PINS
2- AUTHORITY
```

5.2.1 Personal Identification Numbers (PIN)

Programmer PIN



Shortcut: 0-PROG, 2-SECURITY, 1-PINS

The Programmer PIN is the code used by the installer to configure and operate the panel. Factory default code is **9876** and may be changed at any time.

The following window appears:

```
PROGRAM PINS
1- PROGRAMR PIN
2- USER PINS
```

Press [1] for programmer PIN. The following window appears:

```
USER 0
ENTER PIN:_____
```

Enter the PIN and press [#]/Enter]. After you have programmed the programmer PIN, the previous window appears.

Program User PINs



Shortcut: 0-PROG, 2-SECURITY, 1-PINS

Up to 15 additional user codes (or up to 99 additional users when the D7039 is installed) can be programmed to protect the system from unauthorized operation and allow a record to be kept of actions by individual system users.

The following window appears:

```
PROGRAM PINS
1 - PROGRAMR PIN
2 - USER PINS
```

Press [2/▲] for user PINs. The following window appears:

```
OTHER PINS
USER (01-15)
```

Enter the user for whom you want to program a PIN and press [#]/Enter]. Example: For User 5, press [5]. The following window appears:

```
USER 5
ENTER PIN: _____
```

Enter the PIN and press [#]/Enter]. After you have programmed the user PIN, the previous window appears.

5.2.2 Authority



Shortcut: 0-PROG, 2-SECURITY, 2-AUTHORITY

This feature determines which system actions a user can perform. Refer to *Table 18*.

Table 18: PIN Authority Levels.	
PIN Authority Level	Allowed Operations
Maximum (1)	All control panel operations, including programming and disable.
Medium (2)	System test modes, fire drill, reset, silence, view history.
Minimum (3)	Silence, view history.
None (0)	None.

The following window appears:

```
AUTHORITY
USER (01 - 15)
```

Enter the user for whom you want to program the authority level and press [#]/Enter]. The following window appears and scrolls through the following choices:

```

USER 1 ATHRY ( )
0- NONE
1- MAXIMUM
2- MEDIUM
3- MINIMUM
    
```

Press the number key that corresponds to your selection. The existing setting is shown in parentheses on the first line. After you have programmed the user authority, the previous window appears.

5.3 PROG SYSTEM

```

PROG SYSTEM
1 - (reserved)
2 - TIMERS
3 - AC LINE SYNC
4 - OPTION BUS
5 - PIN REQUIRED?
6 - (reserved)
7 - REMOTE PGM
    
```

5.3.1 Program Timers



Shortcut: 0-PROG, 3-PROG SYSTEM, 2-TIMERS

The following window appears:

```

TIMERS
1- SMOKE RESET
2- AC FAIL DLY
3- AUTO SILENCE
4- (reserved)
5- DISPLAY RATE
    
```

Smoke Reset



Shortcut: 0-PROG, 3-PROG SYSTEM, 2-TIMERS

This feature determines how long the smoke detector power is off after reset. No alarms are registered by the system for 5 seconds after power is returned.

The display scrolls through the TIMERS options. Press [1] for Smoke Reset. The following window appears:

```

SMOKE RESET (__)
(1-16 SECS): __
    
```

Enter the time and press [#]/Enter]. The existing setting is shown in parentheses on the first line. After you have programmed the smoke reset, the previous window appears.

AC Fail Delay



Shortcut: 0-PROG, 3-PROG SYSTEM, 2-TIMERS

This feature sets the number of hours the control panel waits after an AC failure before sending an AC Failure report. A setting of DC causes the system to send a report when 25% of the battery capacity is used.

The display scrolls through the TIMERS options. Press [2] for AC FAIL DELAY. The following window appears:

```

AC FAIL DELAY
1- WAIT FOR DC
2- ENTER TIME
    
```

The wait for DC function causes the AC fail report to be sent when the battery is 25% depleted, based on the measured voltage of the battery. If you want to WAIT FOR DC (25 percent of capacity), press [1]. The existing setting is displayed in parentheses on the first line, either “DC”, or the number of hours selected. After you program the AC Fail Delay, the previous window appears.

To ENTER TIME press [2]. The following window appears:

```

AC FAIL DLY (__)
(00-24 HRS): ____*
    
```

* Refer to *Table 15* on page 32.

Enter the time and press [#]/Enter]. The existing setting is shown in parentheses on the first line. After you program the AC Fail Delay, the previous window appears.



When Wait For DC is the existing selection, the Enter Time menu displays DC as the time in hours.

Auto Silence



Shortcut: 0-PROG, 3-PROG SYSTEM, 2-TIMERS

This feature silences the sounding of an alarm condition on selected NACs after a certain amount of time. When you use Auto Silence, pressing [0/Prog] disables the feature and the only way to turn off an alarm is to manually silence it. Entering between 5 and 99 minutes means that the alarm sounds for that much time before automatically silencing.



If the condition is not corrected after an alarm is silenced (automatically or manually), the alarm sounds again after 24 hours.



The system must eventually be reset after silencing to allow the alarmed zones to restore and detect new alarms.

The display scrolls through the TIMERS options. Press [3] for AUTO SILENCE. The following window appears:

```

AUTO SILENCE (__)
(0, 5-99 min): ____
    
```

Enter desired length of time (or press [0/Prog] to disable) and press [#]/Enter]. The existing setting is shown in parentheses on the first line. After you program the auto silence, the previous window appears.

Display Rate



Shortcut: 0-PROG, 3-PROG SYSTEM, 2-TIMERS

Set the speed at which menus are displayed on the LCD (in units of 0.25 sec).

The display scrolls through the TIMERS options. Press [5] for DISPLAY RATE. The following window appears:

```
DSPLY RATE ( )
.25 X (1-16): ___
```

Enter desired value and press [#/Enter]. The existing setting is shown in parentheses on the first line. After you program the display rate, the previous window appears.

5.3.2 AC Line Synch



Shortcut: 0-PROG, 3-PROG SYSTEM, 3-AC LINE SYNC

When AC power is available, the control panel uses the line frequency to stabilize the real-time clock. This setting must match the frequency of the local AC power (60 Hz in the US).

The following window appears:

```
AC LINE SYN ( )
1- 50 Hz
2- 60 Hz
```

Press the number key that corresponds to your selection and press [#/Enter]. The existing setting is shown in parentheses on the first line. After you program AC Line Synch, the previous window appears.

5.3.3 Option Bus

Update Bus



Shortcut: 0-PROG, 3-PROG SYSTEM, 4-OPTION BUS

When devices are added or removed from the option buses, this feature queries both option buses and updates the list of connected devices. This enables the new devices and removes supervision for devices no longer present.



Be sure the count of devices displayed when this operation completes matches the number of devices installed on both buses. Devices not detected during the update bus operation will not operate and will not be supervised.



These menu items are allowed only at the local keypad.

The following window appears:

```
OPTION BUS (M/M)
1- UPDATE BUS
2- SETUP KEYPDS
```

Press [1] to program the system to update the bus. After you program Update Bus, the following window appears:

```
UPDATE COMPLETE
TOT BUS DEVS: X
```

Then the previous window appears.

Keypad Setup



Shortcut: 0-PROG, 3-PROG SYSTEM, 4-OPTION BUS

This feature tells the system how many keypads to supervise. It automatically performs an update bus operation as it completes.

```
OPTION BUS
1- UPDATE BUS
2- SETUP KEYPDS
```

Press [2] to set up keypads. The following window appears:

```
# OF KEYPADS (__)
(0-4): ____
```

Enter the desired value and press [#/Enter]. The existing setting is shown in parentheses on the first line. After you set up the keypads, the update bus operation proceeds, then the previous window appears.

5.3.4 PIN REQUIRED

Local



Shortcut: 0-PROG, 3-PROG SYSTEM, 5-PIN REQUIRED?

A PIN can be required before performing operations. Enter the PIN at the local or built-in keypad.

The following window appears:

```
PIN REQUIRED?
1- LOCAL
2- REMOTE
```

Press [1] to require a PIN at the local keypad. The following window appears:

```
LOCAL KEYPD PIN?
___:YES(1)NO(0)
```

Press the number key that corresponds to your selection. The existing setting is shown in front of the colon on the second line. After making your selection, the previous window appears.

Remote



Shortcut: 0-PROG, 3-PROG SYSTEM, 5-PIN REQUIRED?

The following window appears:

```
PIN REQUIRED?
1- LOCAL
2- REMOTE
```

Press [2] to select remote PIN. The following window appears:

```
REMOTE KYPD PIN?
___: YES (1) NO (0)
```

Press the number key that corresponds to your selection and press [#/Enter]. Refer to *Table 15* on page 32. The existing setting is shown in front of the colon on the second line. After you select the PIN requirement, the previous window appears.



A PIN can be required before operations can be performed using the remote keypads on the option bus. If the remote keypads are not otherwise secured, this option must be set to YES to comply with NFPA and Local requirements.

5.3.5 Remote Programming



Shortcut: **0-PROG, 3-PROG SYSTEM, 7-REMOTE PGM**

Remote programming allows the panel to be called from a remote site by phone to reconfigure any of the programmable options. When remote programming is disabled, you can still connect to the control panel for diagnostics and to view the existing program. PIN numbers are suppressed while remote programming is disabled.

REMOTE PGM
0- DISABLE
1- ENABLE

Press [0/Prog] to select DISABLE or [1] to select ENABLE, and the previous window appears.



After any programming change, and especially after remote program changes, completely check operation of the control units. Hazards to life and property can result if the system is not tested for incorrect programming.

5.4 PROG INPUTS

PROG INPUTS
1- POINT NUMBER
2- POINT FUNCT
3- POINT COPY



Point functions allow quick programming of similarly functioning points (for example, pull stations, smoke detectors) with common settings. Refer to *Section 5.4.2 Point Function* on page 50, for more information.

5.4.1 Point Number



Shortcut: **0-PROG, 4-PROG INPUTS, 1-POINT NUMBER**

POINT NUMBER (1-255): __

Enter the point number you wish to program and press [#/Enter]. Once you have entered the point number, the display scrolls through the following PROG INPUT options:

PROG POINT
0- FUNCTION
1- ALARM/TROUBL
2- OUTPUT ZONE
3- VERIFICATION
4- LATCHING
5- DESCRIPTION
<DRILL> NEXT PNT
<HIST> PREV PNT

Press the number key that corresponds to your selection.

Pressing [Drill] retrieves the next point. For instance, if you are programming Point 2 and you press [Drill], you retrieve the setting for Point 3.

Pressing [History] retrieves the previous point. For instance, if you are programming Point 2 and you press [History], you return to the setting for Point 1.

Assigning Point Functions



Shortcut: 0-PROG, 4-PROG INPUTS, 1-POINT NUMBER

This feature assigns each point to one point function. A point function is a set of characteristics that you can assign to selected points. There are 16 point functions to choose from. Refer to *Section 4.2 Point Programming* on page 33 for more information.



Refer to *Loop Response* on page 51 for the limitations when assigning points to point functions that were programmed with a response time other than Fast.

Enter the point number you wish to program and press [#]/Enter]. The display scrolls through the PROG INPUT options.

Press [0/Prog] to select FUNCTION. The following window appears:

```
POINT FUNC. ( )
(01 - 16): ___
```

Enter the function number you wish to assign to the point and press [#]/Enter]. The existing setting is shown in parentheses on the first line. After you assign a point function, the previous window appears.

Alarm/Trouble Status



Shortcut: 0-PROG, 4-PROG INPUTS, 1-POINT NUMBER

This feature allows you to program the system response to an open loop condition. A shorted loop always causes an alarm condition. Refer to *Table 15* on page 32.

ALARM: A point in an open circuit state causes an alarm.

TROUBLE: If a point is in an open circuit state, the system responds with a trouble condition.

Enter the point number you wish to program and press [#]/Enter]. The display scrolls through the PROG INPUT options.

Press [1] to select ALARM/TROUBLE. The following window appears:

```
OPEN STATUS ( )
1- ALARM
2- TROUBLE
```

Press [1] to select ALARM on open loop and ALARM on shorted loop or [2] to select TROUBLE on open loop and ALARM on shorted loop. The previous window appears. The existing setting is shown in parentheses on the first line.

Output Zones



Shortcut: 0-PROG, 4-PROG INPUTS, 1-POINT NUMBER

Enter the point number you wish to program and press [#]/Enter]. The display scrolls through the PROG INPUT options.

Press [2] to select OUTPUT ZONE. The following window appears:

```
OUTPUT ZONE ZZZ
(01 - 50): ___
```

Press the number key that corresponds to your selection. **ZZZ** indicates the point being programmed. The existing setting is shown on the second line. After you set up the output zone, the previous window appears.

Verification



Shortcut: 0-PROG, 4-PROG INPUTS, 1-POINT NUMBER

This feature resets the detector once to determine if the alarm recurs before annunciating or sending a signal. The total delay introduced by this feature is equal to the smoke power reset time plus five seconds. Alarm verification cannot be selected for points that are configured as WATERFLOW or SUPERVISORY types.

Enter the point number you wish to verify and press [#]/Enter]. The display scrolls through the PROG INPUT options.

Press [3] to select VERIFICATION. The following window appears:

```
ALARM VERIF (ZZZ)
_____:YES(1)NO(0)
```

ZZZ indicates the point being programmed. The existing setting is shown on the second line.

Press either [1] to verify or [0]/Prog] to not verify. The previous window appears.

Latching



Shortcut: 0-PROG, 4-PROG INPUTS, 1-POINT NUMBER

If a zone is non-latching, the system resets the alarm status automatically (but does not reset smoke power) when the input restores to the standby condition. Otherwise, the system must be manually reset. Refer to Table 15 on page 32.

Enter the point number you wish to program and press [#]/Enter]. The display scrolls through the PROG INPUT options.

Press [4]/] to select LATCHING. The following window appears:

```
LATCHING? ZZZ
_____:YES(1)NO(0)
```

ZZZ indicates the point being programmed. The existing setting is shown on the second line.

Press the number key that corresponds to your selection. Select YES for alarm.

The previous window appears.

Point Description



Shortcut: 0-PROG, 4-PROG INPUTS, 1-POINT NUMBER

For this feature, use the numeric keys to enter alphanumeric information to identify each input (such as initiating circuit). The system allows one 16-character description per input.

Enter the point number you wish to program and press [#]/Enter]. The display scrolls through the PROG INPUT options.

Press [5] to select DESCRIPTION. The following window appears:

```
PNT DSCRPTN ZZZ:
_____
```

Enter the description using the numeric, [Silence] and [History] keys, then press [#]/Enter] to save the description.

5.4.2 Point Function



Shortcut: 0-PROG, 4-PROG INPUTS, 2-POINT FUNCTION

There are 16 point functions, each of which has programmable features for: configuration (fire, waterflow, and so on), local only operation, silencing, and loop response.

The following window appears:

```
POINT FUNC. ( )
(01 - 16): ___
```

Enter the function number you wish to program and press [#]/Enter]. The following window appears:

```
PROG FUNCT
0- CONFIGURE
1- LOCAL ONLY
2- (reserved)
3- SILENCABLE
4- LOOP RESPONS
5- (reserved)
<DRILL> NXT FCT
<HIST> PREV FCT
```

Enter the function you wish to program.

Configure



Shortcut: 0-PROG, 4-PROG INPUTS, 2-POINT FUNCTION

1. **Fire:** When activated, the point shows FIRE ALARM on control panel and keypads, activates selected output devices, and sends a Fire Alarm report (if programmed). Fire points are defaulted to a latch when first configured.
2. **Waterflow:** When activated, the point shows WATERFLOW ALARM on control panel and keypads, activates selected output devices, and sends a Waterflow Alarm report (if programmed). Waterflow points are defaulted to a non-verify characteristic when first configured.
3. **Supervisory:** When activated, the point shows SUPERVISORY ALARM on control panel and keypads, and sends a Supervisory Alarm report (if programmed). Supervisory points are defaulted to a non-verify characteristic when first configured.
4. **Reset:** When activated, the point initiates a control panel-reset operation to clear alarms and reset smoke detectors. Only points 1 to 8 can be configured as reset points.
5. **Silence:** When activated, the point initiates a control panel silence operation to turn off sounders if the control panel is configured to allow silencing. Only points 1 to 8 can be configured as silence points.
6. **AC Fault:** When activating, the control panel waits for the AC Delay Timer to expire before indicating or sending a trouble condition. When the timer expires, it shows an AC Fault on the control panel and the trouble LED turns on.

Enter the point number you wish to program and press [#]/Enter]. The display scrolls through the PROG FUNCTION options.

Press [0/Prog] to select CONFIGURE. The following window appears:

ACTVTN TYPE ()
1- FIRE
2- WATERFLOW
3- SUPERVISORY
4- (reserved)
5- RESET
6- SILENCE
7- AC FAULT

Press the number key that corresponds to your selection. (The existing setting is shown in parentheses on the first line.) The previous window appears.

Local Only



Shortcut: 0-PROG, 4-PROG INPUTS, 2-POINT FUNCTION

Enabling this feature provides the input point for local annunciation only, with no communicator report.

Enter the point number you wish to program and press [#/Enter]. The display scrolls through the PROG FUNCTION options.

Press [1] to select LOCAL ONLY. The following window appears:

LOCAL ONLY
____: YES (1)NO(0)

Press either [1] to enable or [0/Prog] to disable. The previous window appears.

Silencing



Shortcut: 0-PROG, 4-PROG INPUTS, 2-POINT FUNCTION

This feature determines if a user may silence the system or not.



When an output is controlled by at least one zone activated by a Non-silencing point or a Non-silencing zone (for example, zone 53), it becomes a Non-silencing output even if other silencing zones activate it.

Enter the point number you wish to program and press [#/Enter]. The display scrolls through the PROG FUNCTION options.

Press [3] to select SILENCEABLE. The following window appears:

SILENCABLE? (FF)
____: YES (1)NO(0)

Press either [1] to enable or [0/Prog] to disable. The previous window appears.

FF indicates the function being programmed.

Loop Response



Shortcut: 0-PROG, 4-PROG INPUTS, 2-POINT FUNCTION

This feature allows you to configure points to activate with standard response time (setting 1) or one system-wide programmed response time (setting 2).

Enter the point number you wish to program and press [#/Enter]. The display scrolls through the PROG FUNCTION options.

Press [4/1] to select LOOP RESPONSE. The following window appears:

RESPNS TIME (__)
1- FAST (.5 sec)
2- PRGRMMD*

* Refer to Table 15 on page 32.

Press the number key that corresponds to your selection (the existing setting is displayed in parentheses on the first line). The previous window appears.

When you select a programmed response time, the system asks you to enter a response time from 1 to 89 sec that applies to all functions. All functions share a single programmable response time setting. If this time is set for multiple functions, the last time set is used.

When set for fast response operation, multiplex points typically have a response time. Response time is (the maximum time an input must be held to guarantee an alarm) of approximately 1 sec. Response time increases as points on the bus remain off-normal (in alarm or with a loop or detector trouble), to a maximum of 20 sec in the extreme case of all points on the bus being in trouble and one point in alarm. On a fully loaded system with only a few points in alarm or trouble, fast response time remains at approximately 1 sec. For programmed response, the response time tolerance is + or - 3 sec when only a few points are off-normal, and increases by up to 20 sec when all points are off-normal.

On-board points have a response time tolerance of + or - 1 sec for programmed response time, and +0.5 or - 0.25 sec for fast response time.



Up to 20 points can be assigned to point functions that were programmed with a response time other than Fast. If more than 20 points are assigned to functions programmed with a response time other than Fast, an error message appears: MAX PROGRAMD POINTS EXCEEDED. Switching a point function from Fast to Programmed can cause this error, depending on how many points reference the point function.

<DRILL> NEXT FCT: Pressing [Drill] retrieves the next function. For instance, if you are programming Point Function 2 and you press [Drill], you retrieve the setting for Point Function 3.

<HIST> PREV FCT: Pressing [History] returns you to the previous function. For instance, if you are programming Point Function 2 and you press [History], you return to the setting for Point Function 1.

5.4.3 Point Copy



Shortcut: 0-PROG, 4-PROG INPUTS, 3-POINT COPY

Point copy allows you to copy the settings you entered for one point to one or more other points.

The following window appears:

COPY FROM POINT: ____

Enter the point you wish to copy from and press [#]/Enter].

COPY TO FIRST POINT: ____

Enter the first point you wish to copy to and press [#]/Enter].

COPY TO LAST POINT: ____

Enter the last point you wish to copy to and press [#]/Enter]. The PROG INPUTS menu appears.

This feature does not copy the description. Point copy is intended for use only on input points. Do not copy from an output point (future use), or copy over a programmed output point. The copy operation automatically stops, with an error message, if outputs are encountered. While copying to a large number of points, the remote keypads might briefly show system fault, because the keypads are not updated during the copy operation.

5.5 PROG OUTPUTS

PROG OUTPUTS
1- NACs
2- RELAYS

5.5.1 Programming NACs



Shortcut: 0-PROG, 5-PROG OUTPUTS, 1-NACs

The main control panel includes two local NACs (NAC 1 and NAC 2). The FPD-7024 can also support up to four FPP-RNAC-8A-4C Remote NAC Power Supplies, which offers a total of 16 remote NACs (four NACs per RNAC).

The following window appears:

NAC OUTPUTS
1- LOCAL
2- REMOTE 1
3- REMOTE 2
4- REMOTE 3
5- REMOTE 4

Press the number key that corresponds to your selection.

Local NACs



Shortcut: 0-PROG, 5-PROG OUTPUTS, 1-NACs

The display scrolls through the NAC options. Press [1] for LOCAL.

The following window appears:

ONBOARD NAC
1- NAC #1
2- NAC #2

Press the number key that corresponds to your selection.

The display scrolls through the following selection:

PROG NAC
1- (reserved)
2- CONFIGURATION
3- ZONE ASSIGNS

Press the number key that corresponds to your selection.

If you select [2] from the PROG NACs menu, the following selections scroll:

NAC CONFIG ()
1- STEADY
2- PULSING
3- CALIFORNIA MARCH
4- TEMPORAL
5- WHEELLOCK
6- GENTEX
7- SYSTEM SENSOR

For more **NAC CONFIG** parameter information, refer to *Table 15* on page 32.

These selections control the pattern (code) for the selected NAC. Press the number key that corresponds with the desired pattern:

- **Steady:** Output turns on and stays on while the NAC is active.
- **Pulsing:** Output turns on for 0.5 sec and off for 0.5 sec.
- **California March:** Output turns on for 0.25 sec and off for 0.25 sec.

- **Temporal:** Output turns on and off to implement the ANSI standard evacuation pattern (Temporal code 3).
- **Wheelock:** Output is configured to support Wheelock devices with synchronization capability, including the ability to silence the horn of a combination horn strobe. The Wheelock configuration is not supported by remote NACs implemented using a Remote NAC power supply.
- **Gentex:** Output is configured to support Gentex devices with synchronization capability, including the ability to silence the horn of a horn strobe combination.



The **Gentex** option does not synchronize to the UL864 9th Edition standard.

- **System Sensor:** Output is configured to support System Sensor devices with synchronization capability, including the ability to silence the horn of a horn strobe combination.

After you program the desired pattern configuration, the previous window appears.

If you select 3 from the PROG NACs menu, you are asked to enter four zones to activate this output.

OUTPUT ZONE A (XX)
(00-63):



“XX” indicates the existing setting for each of the four output zone settings.

Enter the desired zone to activate this output and press [#]/Enter]. You are asked to enter up to four zones (A, B, C, D). Enter 00 (or leave it set at “00”) for any unused zones to prevent unintentional output activation. After all four zones are programmed, the previous window appears.

Table 19: Pre-Assigned Zone Quick Reference

Zone	Pre-Assigned Condition
52	General Fire Alarm (non-silencing)
53	General Fire Alarm, (silencing)
54	Ground Start
55	General Supervisory, (silencing)
56	General Waterflow, (silencing)
57	Communication Trouble
58	General Supervisory Alarm (non-silencing)
59	Alarm Verification
60	AC Failed
61	General Waterflow Alarm (non-silencing)
62	General Trouble
63	General Alarm, Waterflow Supervisory (non-silencing)

Remote NACs



Shortcut: 0-PROG, 5-PROG OUTPUTS, 1-NACs

Use only with the FPP-RNAC-8A-4C. The display scrolls through the NAC options. Press [2] for REMOTE 1, [3] for REMOTE 2, [4/] for REMOTE 3, or [5] for REMOTE 4. One of the following windows appears:

REM EXP NAC #1 1 - NAC #1 2 - NAC #2 3 - NAC #3 4 - NAC #4	or	REM EXP NAC #2 1 - NAC #1 2 - NAC #2 3 - NAC #3 4 - NAC #4	or	REM EXP NAC #3 1 - NAC #1 2 - NAC #2 3 - NAC #3 4 - NAC #4	or	REM EXP NAC #4 1 - NAC #1 2 - NAC #2 3 - NAC #3 4 - NAC #4
--	----	--	----	--	----	--

Press the number key that corresponds with the NAC you want to program. The display scrolls through the following selections:

PROG NACs 1- (reserved) 2- CONFIGURATION 3- ZONE ASSIGNS

The options for remote NACs are the same as for local NACs.

Output Configuration:

- **Steady:** Programmed to turn on steadily for a fire alarm.
- **Pulsing:** Programmed to pulse for a fire alarm at 0.5 sec on and 0.5 sec off.
- **Temporal:** Programmed to pulse for a fire alarm in Temporal 3.
- **Zone Assignment:** Assign each output up to four zones. ZONE A, B, C, or D (00 = disabled) (1 to 63).

Press the number key that corresponds to your selection. After you program the local NACs, the previous window appears.

5.5.2 Programming Relays



Shortcut: 0-PROG, 5-PROG OUTPUTS, 2-RELAYS

The main control panel includes three on-board relays (Relay 1, Relay 2, and Relay 3). The FPD-7024 can also support up to two D7035 Octal Relay Modules (Remote Relay 1 and Remote Relay 2), that offer a total of 16 remote relays (eight relays per module).

The following window appears:

RELAY OUTPUTS 1- LOCAL 2- REMOTE 1 3- REMOTE 2 4- MULTIPLEX

Press the number key that corresponds to your selection.



The option for multiplex relay programming is visible only if the D7039 Multiplex Expander is installed.

Local Relays



Shortcut: 0-PROG, 5-PROG OUTPUTS, 2-RELAYS

The display scrolls through the Relay options.

Press [1] for LOCAL. The following window appears:

ONBOARD RELAY
(1-3):

Enter the number corresponding to the relay to be programmed and press [#]/Enter]. The display asks you to enter four zones to activate this output:

OUTPUT ZONE A: ___
(00 - 63): ___

Enter the first zone (00 to 63) you want to assign to this output and press [#]/Enter]. A similar display for Zones B, C and D will appear to allow up to four zones to be assigned to this output. When all four zones are assigned, the previous window appears.

Table 20: Pre-Assigned Zone Quick Reference

Zone	Pre-Assigned Condition
52	General Fire Alarm (non-silencing)
53	General Fire Alarm, (silencing)
54	Ground Start
55	General Supervisory, (silencing)
56	General Waterflow, (silencing)
57	Communication Trouble
58	General Supervisory Alarm (non-silencing)
59	Alarm Verification
60	AC Failed
61	General Waterflow Alarm (non-silencing)
62	General Trouble
63	General Alarm, Waterflow Supervisory (non-silencing)

An output point cannot be assigned to more than four zones. Each output does not need to be assigned to four zones. Each zone can have any number of outputs assigned to it.

Remote Relays



Shortcut: 0-PROG, 5-PROG OUTPUTS, 2-RELAYS

The display scrolls through the Relay options. Press [2] for REMOTE 1 or [3] for REMOTE 2. The following window appears:

REMOTE RELAY @ x
(1 - 8):



The @ x shows the address of the relay module in the system. The lower number address is Relay 1; the higher one is Relay 2.

When you address a MUX Module, you assign an address. If you have a dual point, it would have two consecutive addresses.

Enter the relay you wish to assign and press [#]/Enter]. The display shows:

OUTPUT ZONE A: ___
(00-63): ___

Enter the output number (00 to 63) you want to assign to Zone A and press [#]/Enter]. A similar display for Zone B appears. When all four zones are assigned, the previous window appears.

Table 21: Pre-Assigned Zone Quick Reference

Zone	Pre-Assigned Condition
52	General Fire Alarm (non-silencing)
53	General Fire Alarm, (silencing)
54	Ground Start
55	General Supervisory, (silencing)
56	General Waterflow, (silencing)
57	Communication Trouble
58	General Supervisory Alarm (non-silencing)
59	Alarm Verification
60	AC Failed
61	General Waterflow Alarm (non-silencing)
62	General Trouble
63	General Alarm, Waterflow Supervisory (non-silencing)

An output point cannot be assigned to more than four zones. Each output does not need to be assigned to four zones. Each zone can have any number of outputs assigned to it.

Multiplex Relays



Shortcut: 0-PROG, 5-PROG OUTPUTS, 2-RELAYS



Do not use this menu to program addresses configured as inputs.

The display scrolls through the Relay options. Press [4/] for MULTIPLEX. The following window appears:

MUX OUTPUT
(009 - 255):

Enter the number corresponding with the output to be programmed and press [#]/Enter]. The output number of a multiplex relay is the second point of an I/O module. Adding 1 to the address of the I/O module gives the address of the relay in the module. When the relay is selected, the display asks you to enter four zones to activate this output:

OUTPUT ZONE A:
(00 - 63):

Enter the first zone (00 to 63) you want to assign to this output and press [#]/Enter]. A similar display for Zone B, C and D appears, allowing up to four zones be assigned to this input. When all four zones are assigned, the previous window appears.

An output point cannot be assigned to more than four zones. Each output does not need to be assigned to four zones. Each zone can have any number of outputs assigned to it.

5.6 PROG ACCOUNTS

PROG ACC'NTS
1- PHONE / IP NUMS
2- PHON CONTROL
3- RPT STEERING
4- RING COUNT
5- COMM. TRIES
6- MACH. BYPASS
7- ALT.COMM
SERIAL/NETWORK

5.6.1 Phone Numbers/IP Addresses



Shortcut: 0-PROG, 6-PROG ACC'NTS, 1-PHONE/IP NUMS

The system can be programmed with two reporting phone numbers or IP addresses. Phone/IP #1 is used with Account Number 1; Phone/IP #2 is used with Account Number 2. Remote programming occurs on Line 1 using Phone/IP #3.

PHONE/IP #1: Phone Number 1 or IP address 1

PHONE/IP #2: Phone Number 2 or IP address 2

COMPTR PHONE: Sets the Phone Number or IP Address to call for remote programming.

Refer to *Table 15* on page 32.

The following window appears:

PHONE /IP NUMBER
1- PHONE /IP #1
2- PHONE /IP #2
3- COMPTR PH/IP

Press the number key that corresponds with the phone number you wish to configure (example is Phone #1).

The following window appears:

PHONE /IP NUMBER #1
1- NUMBER
2- PORT NUMBER
3- FORMAT
4- ACCT NUMS
5- TONE

Press the number key that corresponds with your selection. Refer to the next four sub-sections (Number, Format, Account Numbers and Tone) for explanations of the phone number options.

Number

The display scrolls through the Phone /IP Number options. Press [1] for NUMBER. The following window appears:

PHONE /IP NMBR 1: >????
????????????????

Press [1]. Press [TEST][4] to add the wait for dial tone, and then enter the phone number and press [#]/Enter]. The previous menu appears. You can include several other special control characters in the phone number by pressing [Test] followed by a digit (*Table 22*).

Table 22: Phone Number Control Characters

Press	See	Action
[TEST] 1	*	Touch Tone “*”
[TEST] 2	#	Touch Tone “#”
[TEST] 3	/	Three-second delay
[TEST] 4	>	Wait for dial tone

Several keys assist when you enter phone or IP numbers (refer to *Table 23* on page 59).

Table 23: Phone Number Assistance Keys

Press	Action
[SILENCE]	Advance to next position
[DISABLE]	Go back one position
[RESET]	Clear position



If the wait for dial tone is not specified, the control panel waits 7 sec after going off-hook, and then dials whether or not the dial tone is present.



For a phone number, you must enter **1** as a prefix before the special character **>**. Except for unusual situations, all phone numbers should have the wait for dial tone character as the second digit. This ensures that reports are delivered as quickly as possible, even if an incoming phone call must be disconnected. For example, you would program **1>18002890096** for the phone number 1-800-289-0096.

To enter a central station IP address in either phone number 1 or 2 in the control panel, replace all three phone numbers with an IP address. To distinguish an IP address from a phone number, enter 0 as the first digit, followed by the 12 digit IP address.



The IP address must be 12 digits long.

For example, if the IP address is 172.30.1.101, the phone number is programmed as 0 172 030 001 101. Do not add the spaces. They are included for readability.

Table 24: IP Address Digit or Bit Location							
Digit 1	Digit 2	Digit 3	Digit 4	Digit 5	Digit 6	Digit 7	Digit 8
0 = Alt. Comm. On	IP1	IP2	IP3	IP4	IP5	IP6	IP7
Digit 9	Digit 10	Digit 11	Digit 12	Digit 13	Digit 14	Digit 15	Digit 16
IP8	IP9	IP10	IP11	IP12	Ack wait N2	Ack Wait N1	Ack Wait N0
Digit 17	Digit 18	Digit 19	Digit 20	Digit 21	Digit 22	Digit 23	Digit 24
HB interval N2	HB interval N1	HB interval N0	1 = Anti-Replay On	0 (unused)	0 (unused)	0 (unused)	0 (unused)

Acknowledge Wait Time (ACK) – Digits 14 to 16, Default: 013

The alternate communication event, transmission acknowledge wait time, is stored in the phone number location as digits 14, 15 and 16. The wait time is a number from 1 to 255 seconds where the most significant or first digit is D14.

For example, if the necessary wait time is 30 sec, digits 14 through 16 should be 0, 3, 0 respectively

In larger installation sites using alternate communications as a destination, set the wait time to a higher value to compensate for network congestion delays. This wait time is also used for the heartbeat acknowledge wait time. This is calculated using the following formula: Value = (D14 X 100 + D15 X 10 + D16), where DXX is a digit number from *Table 24*. If the programmed value exceeds 255, it is read as 255.

A time-out on an alternate communication path is treated the same way as a negative acknowledgement and results in the same event routing default scheme used with phone reporting (refer to *Table 25* on page 61) to the central station. This allows alternate communications to be the primary or secondary reporting paths to an actual phone number for a single reporting destination.

Attempt	Primary Phone Line (Phone 1)	Secondary Phone Line (Phone 2)
1	1 st phone number	
2	2 nd phone number	
3		1 st phone number
4		2 nd phone number
5	2 nd phone number	
6	1 st phone number	
7		1 st phone number
8		2 nd phone number
9	2 nd phone number	
10	1 st phone number	

Heartbeat Interval (HB) – Digits 17 to 19, Default: 075

This interval is a value between 1 and 255 that indicates the number of seconds between heartbeat events sent from the control panel. The heartbeat event is sent only when the communication path is idle for at least the programmed heartbeat interval period of time. The value is stored in phone number digits 17 through 19 with 17 being the most significant or first digit. A value of zero in these locations disables the heartbeat feature. These digits are always zero in the remote programmer phone number. Use the following formula to calculate this value: Value = (D17 x 100 + D18 x 10 + D19), where DXX is a digit number from *Table 24* on page 60. If the value programmed exceeds 255, it is read as 255.

The heartbeat feature is an acknowledged test event sent to the central station receiver over a network connection. This event does not appear at the central station, and it is not logged in the control panel as an actual event. The heartbeat event is used as a periodic test of the virtual circuit between the control panel and the networked receiver. The heartbeat event is transmitted as a null-modem IIIa² event that uses only the first four digits of the account code for Area 1. The event format always remains the same regardless of the communication protocol formats available in the control panel.

Refer to *Table 15* on page 32.

Anti-Replay – Digit 20, Default: 1

Digit 20 of the phone number enables the Anti-Replay Feature for central station communications. A zero in this location disables this feature. This digit is always zero in the remote programmer phone number.

The purpose of Anti-Replay is to prevent malicious or accidental repetition of event packets to the central station network receiver. A communication packet can be recorded on a network and replayed in its entirety as if it came from the control panel. If for some reason the packets become out of sequence, the communication path generates a communications failure event and must be manually resynchronized.

Port Numbers



Shortcut: 0-PROG, 6-PROG ACC'NTS, 1-PHONE/IP NUMS

The port numbers identify the control panel when it sends reports to the Netcom module. (For normal installation, set this to 07700).

The display scrolls through the Phone or IP Number options. Press [2] for PORT NUMS. The following window appears:

PORT #1:	00000
NEW NUMBER:	00000

The existing number is shown on the top line. Enter the new number on the second line and press [#]/Enter]. The previous window appears. Enter hexadecimal digits A through F by pressing [Test] followed by [1] for A, [2] for B, [3] for C, [4] for D, [5] for E and [6] for F.



Refer to the *DX4020 Installation Guide (P/N: F01U045288)* for more information about using Netcom communications.

Format



Shortcut: **0-PROG**, **6-PROG ACC'NTS**, **1-PHONE/IP NUMS**

Use this feature to select which communication format to use or to disable communication for the phone or IP number. To disable the dialer, set the format for Phone Lines 1 and 2 to disabled and turn off the monitoring feature of both lines.

The display scrolls through the Phone or IP Number options. Press [3] for FORMAT. The following window appears:

PHONE/IP FORMAT (_)	
0-	DISABLE
1-	3/1 REPORT
2-	4/2 REPORT
3-	BSFK REPORT
4-	SIA, 110 RPRT
5-	CONTACT ID
6-	SIA, 300 RPRT
7-	MDM 3A2

Press the number key that corresponds to your selection. The previous window appears.



If using the DX4020 for reporting events only two formats are possible:

- Modem III² – BSFK, SIA 110/300, modem III A²
- Contact ID – 3/1, 4/2, contact ID.

Account Numbers



Shortcut: **0-PROG**, **6-PROG ACC'NTS**, **1-PHONE/IP NUMS**

The account numbers identify the control panel when it sends reports to the central station.

The display scrolls through the Phone or IP Number options. Press [4] for ACCOUNT NUMS. The following window appears:

ACCOUNT #1:	0000
NEW NUMBER:	0000

The existing number is shown on the top line. Enter the new number on the second line and press [#]/Enter]. The previous window appears. Enter hexadecimal digits A through F by pressing [Test] followed by [1] for A, [2] for B, [3] for C, [4] for D, [5] for E and [6] for F.

Tone



Shortcut: **0-PROG**, **6-PROG ACC'NTS**, **1-PHONE/IP NUMS**

The **FREQ ()** programming items (refer to window below) modify the reporting format when 3/1 or 4/2 tone burst reporting is selected for the format. Select three parameters with one setting: data tone frequency, acknowledge tone frequency, and data rate. The frequency that the control panel uses to send data pulses can be set for 1900 Hz (19D) or 1800 Hz (18D). The frequency of the acknowledge tone from the receiver to which control panel responds can be set to 1400 Hz (14A) or 2300 Hz (23A). The rate at which the data pulses are sent can be set to 10, 20, or 40 pulses per second (10PS, 20PS or 40PS).

The display scrolls through the Phone/IP Number options (refer to *Section 5.6.1 Phone Numbers/IP Addresses* on page 58). Press [5] for TONE. The following window appears:

FREQ ()	
1-	19D, 14A, 10PS
2-	18D, 23A, 10PS
3-	19D, 14A, 20PS
4-	18D, 23A, 20PS
5-	19D, 14A, 40PS
6-	18D, 23A, 40PS

Press the number key that corresponds to your selection. The previous window appears.

5.6.2 Phone Control



Shortcut: 0-PROG, 6-PROG ACC'NTS, 2-PHONE/IP CONTROL

In addition to features associated with each phone and IP number, each phone line has associated features.

PHONE CONTROL
1- LINE #1 2- LINE #2

Press the number key that corresponds with your selection. Line 1 and Line 2 have the same options. The following window appears:

PHONE CONTROL #1
1- MONITOR LINE 2- DIALING TYPE

Refer to Monitor Line and Dialing Type in the following sections for explanations about the phone control options.

Monitor Line



Shortcut: 0-PROG, 6-PROG ACC'NTS, 2-PHONE/IP CONTROL

The phone line monitor feature, that supervises the connection of the phone line to the control panel, can be disabled for each phone line. If an IP address is entered for the Phone/IP number, set the monitor to No. If this is not programmed to No, a trouble is generated.

Choose Line 1 or Line 2 (refer to the window above). The display scrolls through the Phone Control options. Press [1] for MONITOR LINE. The following window appears:

MONITOR LINE #1 _____: YES (1) NO (0)*

* Refer to *Table 15* on page 32.

Press [1] for YES or [0/Prog] for NO. The previous window appears.

Dialing Type



Shortcut: 0-PROG, 6-PROG ACC'NTS, 2-PHONE/IP CONTROL

This feature determines the format the control panel uses for dialing on each phone line. The TONE/PULSE setting first tries tone dialing. If that fails, it switches to pulse dialing. If an IP address is entered in for the Phone/IP number, the control panel ignores this setting.

Choose Line 1 or Line 2 (refer to the window below). The display scrolls through the Phone Control options. Press [2] for DIALING TYPE. The following window appears:

PHONE CONTROL ()
1- PULSE ONLY 2- TONE/PULSE 3- TONE ONLY

Press the number key that corresponds to your selection. The previous window appears.

5.6.3 Report Steering



Shortcut: 0-PROG, 6-PROG ACC'NTS, 3-RPT STEERING

Different classes of reports can be directed to different phone numbers. Non-supervisory alarms include fire alarms and waterflow alarms. Supervisory alarms come from points configured as a supervisory type. Non-supervisory restorals include fire and waterflow restorals. Supervisory restorals come only from points configured as a supervisory type. Trouble reports include all point and system troubles and restorals. Tests include Auto Tests, Manual Tests and Off-normal at Test Reports. The control panel allows the special reports Silence, Reset, and Drill to be individually directed.



If any reports are directed to Phone/IP Number 2 (including the default, PHONE 2 BACKUP), a phone number and account number must be programmed for Phone/IP Number 2. The control panel indicates a COMM FAULT if it sends a report (using Phone Number 1 parameters) which references unprogrammed Phone/IP Number 2 parameters.

The display scrolls through the following items:

- | |
|-----------------|
| REPORT STEERING |
| 1- NONSUP ALRM |
| 2- SUPVSY ALRM |
| 3- NONSUP RSTR |
| 4- SUPVSY RSTR |
| 5- TROUBLE |
| 6- TESTS |
| 7- SILENCE |
| 8- RESET |
| 9- DRILL |

Press the number key that corresponds to your selection. Selecting, for example NON-SUPERVISORY ALARM produces the following window:

- | |
|--------------------|
| NONSUP ALRM (__) |
| 1- PHONE/IP 1 ONLY |
| 2- PHONE/IP 2 ONLY |
| 3- PHON/IP 1 AND 2 |
| 4- PHN/IP 2 BACKUP |
| 5- NO REPORT |

PHONE/IP 1 ONLY: Report sent to Phone/IP 1 only.

PHONE/IP 2 ONLY: Report sent to Phone/IP 2 only.

PHONE/IP 1 AND 2: Report sent to Phone/IP Numbers 1 and 2.

PHONE/IP 2 BACKUP: Report sent to Phone/IP 1, then to Phone/IP 2 if 1 fails.

NO REPORT: No report sent.

Press the number key that corresponds with your selection. The previous window appears.

5.6.4 Ring Count



Shortcut: 0-PROG, 6-PROG ACC'NTS, 4-RING COUNT



Set to 0 the number of phone rings before the control panel seizes the line to attempt remote programming.

The number of phone rings before the panel seizes the line to attempt remote programming must remain at 0 for UL 864 local, auxiliary or remote station installations. If an IP address is entered in for the Phone/IP number, the panel will ignore this setting.

When the ring count is set to 0, remote programming must be answered on site. Once answered, the panel will prompt for a password.

The following window appears:

```
RING COUNT
(01-15, 00=DIS) ____
```

Enter the information and press [#]/Enter]. The previous window appears. An entry of [0/Prog] [0/Prog] disables ring detection.

Refer to *Table 15* on page 32.

5.6.5 Communication Tries



Shortcut: 0-PROG, 6-PROG ACC'NTS, 5-COMM. TRIES

The system always tries ten times to communicate an event. This parameter determines after which attempt the system indicates a failure condition. (After reporting a failure, the system continues to communicate until it reaches ten times). Do not select 1 or a failure is indicated whenever a report is sent.

The following window appears:

```
COMM ATTMPTS (__)
(01-10): __
```

Enter the information and press [#]/Enter]. The previous window appears.

5.6.6 Machine Bypass



Shortcut: 0-PROG, 6-PROG ACC'NTS, 6-MACH BYPASS

The downloading computer must redial the control panel if an answering machine answered the phone before the control panel. When this option is selected, if the control panel detects the phone line ringing within one minute of when the last ringing cycle stopped, it answers on the first ring and seizes the phone line. If an IP address is entered in for the Phone/IP number, the control panel ignores this setting.

The following window appears:

```
MACHINE BYPASS
____: YES (1) NO (0)
```

Enter the information and press [#]/Enter]. The previous window appears.

5.6.7 ALT. Comm



Shortcut: **0-PROG**, **6-PROG ACC'NTS**, **7-ALTER COMM**

This prompt is used with the DX4020 or DX4010.

If using the DX4020 select 0 network and if using the DX4010 select 1-serial.

The following window appears:

```
ALTER COMM ( )
0 - NETWORK
1 - SERIAL
```

5.7 PROG FORMATS

```
PROG FORMATS
1 - 4/2 ZONE REPT
2 - 4/2 RPT CODS
3 - BFSK RPT CDS
```



This feature offers the use of hexadecimal digits (0 through F). Because the specific keys A through F are not available on the keypad, use the equivalent keys listed below.

- History: A
- Test: B
- Disable: C
- Drill: D
- Silence: E
- Reset: F

5.7.1 4/2 Zone Report



Shortcut: **0-PROG**, **7-PROG FORMATS**, **1-4/2 ZONE RPTS**

4/2 Zone reports consist of an event type (first digit) and a point number (second digit). These reports apply only to points, and only when a 3/1 or 4/2 format is selected.

The following window appears:

```
4/2 ZONE RPT
0- FIRE ALRM D1
1- FIRE RSTR D1
2- WATERFLOW D1
3- SUPERVISE D1
4- TROUBLE D1
5- TRBL RSTR D1
6- DISABLE D1
7- DSBL RSTR D1
8- (RESERVED)
9- MORE
```

Press the number key that corresponds with your selection of event type (D1 stands for digit 1). Press [#]/Enter].

Pressing [9] retrieves the second digit options (point numbers). The following window appears:

```

4/2 ZONE RPT
1- POINT 1 D2
2- POINT 2 D2
3- POINT 3 D2
4- POINT 4 D2
5- POINT 5 D2
6- POINT 6 D2
7- POINT 7 D2
8- POINT 8 D2
9- MORE
    
```

Press the number key that corresponds with your selection of event type (D2 stands for digit 2). Press [# / Enter].

Pressing [9] retrieves additional second digit options (point numbers). The following window appears:

```

4/2 ZONE RPT
1- POINT 9 D2
2- POINT 10 D2
3- RETURN TO D1
    
```

Press the number key that corresponds to your selection. A window based on your previous selection allowing entry of hex digits appears:

```

FIRE ALARM D1 ( )
0 THRU 9
<HISTORY>:  A
<TEST>:     B
<DISABLE>:  C
<DRILL>:    D
<SILENCE>:  E
<RESET>:   F
    
```

Enter the digit that corresponds to the selected condition by pressing a number key or one of the special keys if a hex character is needed. Press [# / Enter] and the previous display appears.

5.7.2 4/2 Report Codes

4/2 Report Codes apply to system conditions but only when 3/1 or 4/2 format is selected. Two digits can be programmed to be sent for each condition. The conditions that can be programmed are:

- System in test, system in test restore: sent for walk test operations
- Silence: sent when the silence key is pressed
- Fire drill, fire drill restore: sent for fire drill operations
- Open reset report: sent when the reset key is pressed
- Low battery, low battery restore, AC failure, AC failure restore: sent for power problems
- Test report: sent for manual or automatic communicator tests
- Off normal at test: sent if the panel is off-normal at the automatic test time
- Phone trouble, restore: sent for phone line problems
- System trouble, restore: sent for general system problems

4/2 RPT CODS	
0-	SYSTM IN TST
1-	SYS TEST RST
2-	SILENCE
3-	FIRE DRILL
4-	FIRE DRL RST
5-	OPEN RST RPT
6-	LOW BATTERY
7-	LOW BATT RST
8-	AC FAILURE
9-	MORE

Pressing [9] allows programming additional reports:

4/2 RPT CODS	
0-	AC FAIL RST
1-	TEST REPORT
2-	OFF NORM TEST
3-	PHONE 1 TRBL
4-	PN 1 TRB RST
5-	PHONE 2 TRBL
6-	PN 2 TRB RST
7-	SYSTEM TROUB
8-	SYS TRB RST

Pressing [9] returns you to the previous group of reporting codes.

Press the number key that corresponds to your code selection. A window based on your previous selection allowing entry of two hex digits appears:

SYSTM IN TST ()	
0 THRU 9	
<HISTORY>:	A
<TEST>:	B
<DISABLE>:	C
<DRILL>:	D
<SILENCE>:	E
<RESET>:	F

Enter digits that correspond to the selected condition by pressing a number key, or one of the special keys if a hex character is needed. Press [# / Enter] and the previous display appears.

5.7.3 BFSK Report Codes

When BFSK reporting is used, most reporting codes are fixed and do not need programming. There are five reports that the control panel can send that are not standard BFSK codes:

- Off normal at test: Sent if the panel is off-normal at the automatic test time.
- Open reset report: Sent when the reset key is pressed.
- Silence: Sent when the silence key is pressed.
- Fire drill, fire drill restore: Sent for fire drill operations.

BFSK RPT CDS
1- OFF NORM TEST
2- OPEN/RESET
3- SILENCE
4- FIRE DRILL
5- FR DRIL RSTR

Press the number key that corresponds to your report code selection. A window allowing entry of two hex digits appears.

5.8 HISTORY DEFAULTS



Shortcut: **0-PROG, 8-HSTRY DEFLT**

The following window appears:

PROG DEFAULTS
1- CLEAR HSTRY
2- DEFAULT EE
3- ALT 4/2 CDES
4- (reserved)

5.8.1 Clear History



Shortcut: **0-PROG, 8-HSTRY DEFLT, 1- CLEAR HISTORY**

You can use this option to clear some or all of the history records in the system.

The following window appears:

HIST ITEMS= _____
DEL OLDEST 000

Enter the number of history records you wish to delete, and press [#/Enter]. The previous menu appears.

5.8.2 Default EE



This option is only available from the local keypad.



Shortcut: **0-PROG, 8-HSTRY DEFLT, 2- DEFAULT EE**

You can set the control panel back to the original factory-programming configuration with this option. You are asked to press [#/Enter] to complete the operation. Press [* /Back] to cancel the operation.



All programming, including zone configurations and option installations, are lost when this operation is performed. You must turn control panel power off and on after resetting the default, to reinstall the four zone expanders and the MUX expander. You must update the option bus and set up keypads (PROG SYSTEM MENU) to reinstall option bus devices.

The following window appears:

SETTING EEPROM TO DEFAULT...

When the operation is complete, the previous menu appears. This operation takes several minutes when the D7039 Multiplex Expander is installed.

5.8.3 Alternate 4/2 Codes



Shortcut: 0-PROG, 8-HSTRY DEFLTS, 3- ALT 4/2 DEVICES

You can set all of the programming for 4/2 codes to an alternative set of default reports, as described in Appendix D on page 93. To cause a complete control panel default, use the default EE option.

The following window appears:

```
SETTING EEPROM
TO DEFAULT...
```

When the operation is complete, the previous menu appears.

5.9 Program MUX



Shortcut: 0-PROG, 9-PROGRAM MUX



1. Unprogrammed devices on the bus will not operate or be supervised
2. This menu is accessible only when the D7039 Multiplex expander is installed.
3. Do not install more than one device programmed to the same address on the bus. Doing so can inhibit alarm reporting from both devices.



Intermittent trouble reports from a particular MUX point address can indicate that more than one device was programmed to that address.

The following window appears:

```
PROGRAM MUX
1- MUX EDIT
2- MUX PROGRAM
3- BUS TYPE
4- AUTO PROGRAM
```

5.9.1 MUX Edit



Shortcut: 0-PROG, 9-PROGRAM MUX 1- MUX EDIT

To add MUX devices to the system, use the MUX Edit option. Each device must have a unique address programmed using the address switches.

The following window appears:

```
DEVICE TYPE ( )
0- NO DEVICE
2- SINGLE INPUT
3- I/O MODULE
4- MUX SMOKE
5- SMOKE W/FRZ
6- DUAL INPUT
7- OCTAL INPUT
```

Description.....	Model
0- NO DEVICE	
2- SINGLE INPUT	D7044/M, D7045, FMM-7045, D7052(Class A)
3- I/O MODULE	D7053
4- MUX SMOKE	D7050, D7050TH, D343
5- SMOKE W/FRZ	Not Used
6- DUAL INPUT	D7052(Class B)
7- OCTAL INPUT.....	D7042

Press the number that corresponds with the device you are adding or press [0/Prog] if you are removing a device. When the device type is selected, the following window appears:

POINT NUMBER
(009 - 255) 009

Enter the address of the point being added, and press [# / Enter]. The device type window appears again allowing additional devices to be added. Eight points are added at once when the D7042 is added to the control panel.

5.9.2 MUX Program



Shortcut: 0-PROG, 9-PROGRAM MUX, 2-MUX PROGRAM

To add MUX devices to the system simultaneously while programming an address into the device itself, use the MUX Program option. This programs a specified address into the device, and also sets the control panel to use the device.



The D7042 is programmed using switches and cannot be added using the MUX Program feature. Use MUX Edit instead.



All devices must be removed from MUX bus A before programming by removing power from the system, disconnecting the wires to the field devices, and re-powering the system. Failure to disconnect devices results in all devices on loop A being programmed to the new address.

All programming is performed on Bus A, including addresses 129 to 255 that can only be installed on Bus B for operation. Be sure to connect devices with addresses 129 to 255 to Bus B, not to Bus A.

If no devices are connected on Bus A, the following window appears. Otherwise an error message appears.

PROGRAM MUX
1- NORMAL
2- FAST

Select normal programming to add one or two devices. Select fast programming to program larger quantities of identical devices to sequential addresses.

Normal Programming

If normal programming is selected, the following menu appears allowing selection of the device type being programmed:

DEVICE TYPE ()
0- NO DEVICE
2- SINGLE INPUT
3- I/O MODULE
4- MUX SMOKE
5- SMOKE W/FRZ
6- DUAL INPUT
7- OCTAL INPUT

Description.....	Model
0- NO DEVICE	
2- SINGLE INPUT	D7044/M, D7045, FMM-7045, D7052(Class A)
3- I/O MODULE	D7053
4- MUX SMOKE	D7050, D7050TH, D343
5- SMOKE W/FRZ	Not Used
6- DUAL INPUT	D7052(Class B)
7- OCTAL INPUT.....	D7042

Enter the number that corresponds with the device you are adding, or select 0 if you are removing a device. When the device type is selected, the following window appears:

POINT NUMBER
(009 - 255) 009

Enter the address of the point being added, and press [# / Enter]. The display asks you to attach the device being programmed to the terminals for MUX bus A (see the following window). You can simply hold the

device wires on the terminals for the few seconds it takes to program. The programming operation retries up to three times if the device does not connect right away.

POINT NUMBER 009
ATTACH DEVICE

Then, the display automatically shows:

POINT NUMBER 009
PROGRAMMING

If the device added is an I/O module, you are asked to enter the four zones to control the relay output, just as for other relay devices:

OUTPUT ZONE A: __
(00 - 63): __

Enter the first zone (00 to 63) you want to assign to this output and press [#]/Enter]. A similar display for Zone B, C and D appears allowing up to four zones to control this output. When all four zones are assigned, the previous window appears. It confirms the programming operation and returns to the previous menu.

POINT NUMBER 009
PROGRAMMED

If a device is defective or not connected properly, the control panel shows:

ERROR -
DEVICE FAILED

Fast Programming

Fast programming proceeds the same as normal programming, except that when the device is programmed you are asked to remove the device:

POINT NUMBER 009
REMOVE DEVICE

Then, you are asked to attach the next device at the next address:

POINT NUMBER 010
ATTACH DEVICE

This process continues until you press [*]/Back]. All devices to be programmed must be of the same type.

5.9.3 MUX Bus Type



Shortcut: 0-PROG, 9-PROGRAM MUX 3- BUS TYPE

This option configures the system for two independent Class B, Style 4 buses allowing addresses up to 255.



Class A operation is not supported by the D7042 Eight Input Module; do not select Class A operation.

The following window appears:

MUX BUS TYPE (__)
1- CLASS A
2- CLASS B

Press [2] to select Class B operation if the setting was changed from the default setting. Refer to *D7042/D7042B Multiplex Eight Input Remote Modules Installation Instructions* (P/N: 42638) for wiring details for a Class B configuration.

Refer to the *D7039 Multiplex Expansion Module's Installation Guide* (P/N: 38685) for more information regarding Class A and Class B wiring instructions.

Refer to *Figure 13* on page 74 for mounting locations inside the FPD-7024's enclosure for the D7039 and its I/O module.

Figure 13: D7039 Mounting Location

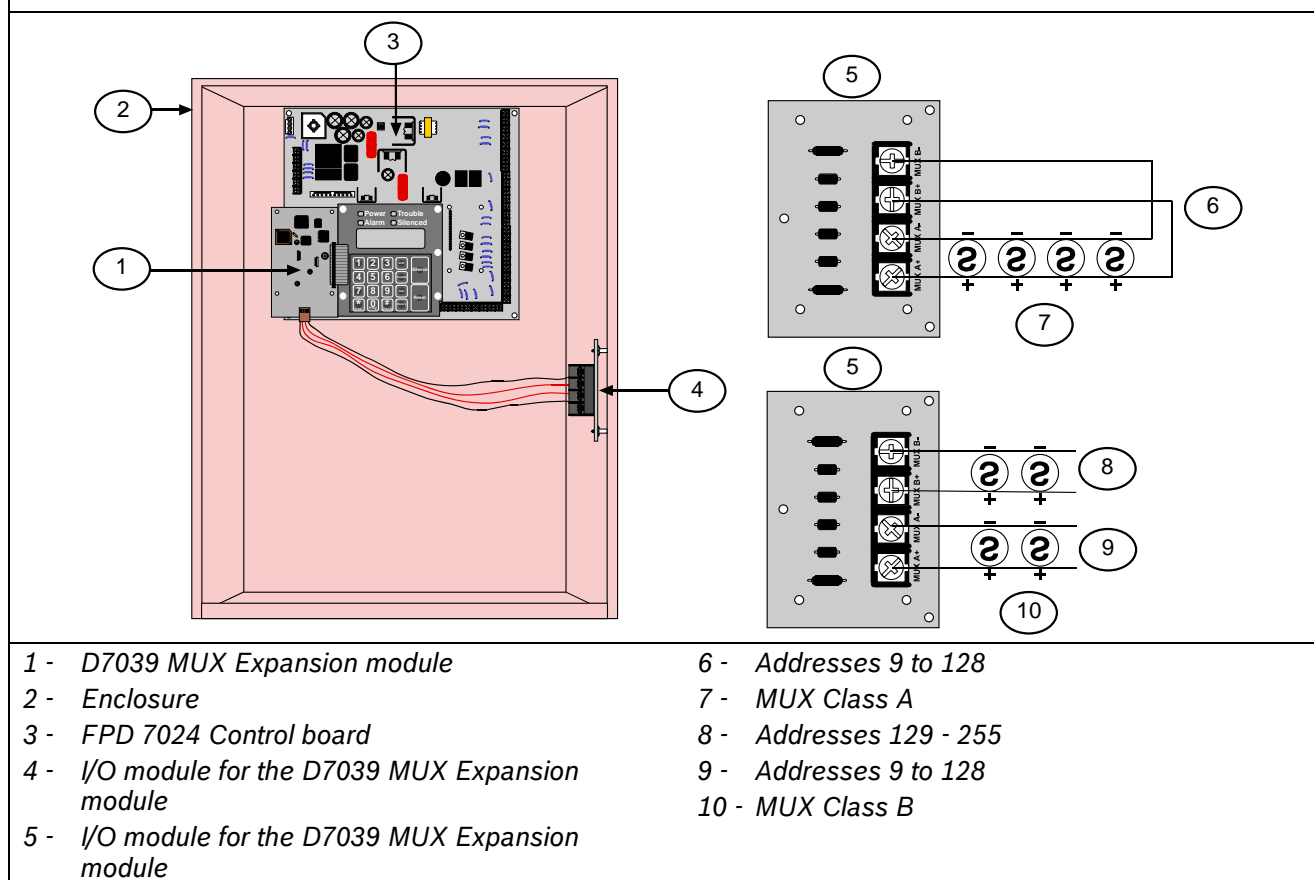

5.9.4 Auto Program



Shortcut: 0-PROG, 9-PROGRAM MUX 4- AUTO PROGRAM

This option provides a convenient way for the installer to configure the FPD-7024 to operate with the existing devices on the multiplex buses by scanning the buses for missing or new multiplex devices.

The following display appears:

```
AUTO PROGRAM?
_____:YES(1)/NO(0)
```

Press [1] to continue with auto programming or [0/Prog] to cancel. When you press [1], the FPD-7024 checks for existing programming errors in which devices are programmed incorrectly in the space required for a lower-addressed multi-point device (such as a dual point module). If a point is found to be programmed under another device, the following error message appears for five seconds, and the auto programming process aborts:

```
ADDRESS ERROR 1
AT ADDRESS xxx
```

If no errors are found, the FPD-7024 starts a scanning process that takes approximately one minute to complete, while showing the following display:

```
AUTO PROGRAM
SCANNING
PLEASE WAIT...
```

When the scanning is completed, the FPD-7024 checks for missing devices. Missing devices are addresses with no devices on the multiplex buses, but are programmed into the FPD-7024's site-specific memory area. If missing devices are detected, the FPD-7024 shows the following menu (where xxx is the address of the first point of the missing device):

```
MISSING PT @ xxx
0- DELETE POINT
1- KEEP POINT
2- DEL REMAIN
3- KEEP REMAIN
```

DELETE POINT: If selected, the missing point and any addresses it implemented (up to eight for an octal input module) are permanently deleted from the site specific memory area. If the deleted device is an I/O module, the output zones that were programmed for the relay are reset to 0. If additional devices are found to be missing, the above display is repeated for each missing device.

KEEP POINT: If selected, the FPD-7024 retains the programming for the existing point and continues scanning for additional missing points.

DEL REMAIN: If selected, the following prompt # KEY TO CONFIRM appears at the FPD-7024. If the [# / Enter] key is pressed, all the missing points are deleted from the site-specific memory area and the auto program process continues with the DEVICES FOUND menu. If any other key is pressed, the existing point is kept and the control panel continues scanning for additional missing devices.

KEEP REMAIN: If selected, no additional points are deleted and the auto program process continues with the DEVICES FOUND menu. Points individually deleted with the DELETE POINT command before selecting the KEEP REMAIN command stay deleted when KEEP REMAIN is selected.



Use the DEL REMAINING feature with caution. Any devices missing from the multiplex buses during the DEL REMAINING operation, even momentarily, are permanently deleted. These points do not operate, and do not generate trouble conditions even if they are returned to the bus.

When the delete point operation is finished, the FPD-7024 shows for five seconds the total number of points that were deleted from the control panel (xxx indicates the number of points that were removed from the control panel's site specific configuration).

```
AUTO PROGRAM
xxx POINTS DELETED
```

Confirm that only the expected number of points was removed from the system. Points that are removed from the control panel's site-specific configuration do not operate and are not supervised even if they are returned to the bus.

When the point delete process completes, the auto programming process automatically checks for new devices on the buses. New devices are found when a device is present on one of the multiplex buses, but its address is not programmed into the control panel's site-specific memory. If new devices are detected, the FPD-7024 shows the following menu (where xxx is the address of the first new device found):

```
NEW DEVICE @ xxx
2 - SINGLE INPUT
3 - I/O MODULE
4 - MUX SMOKE
5 - SMOKE W/FRZ
6 - DUAL INPUT
7 - OCTAL INPUT
0 - NO DEVICE
```

Use this menu to define the device type. Press the number key that corresponds with the device type installed at the address. If a detected device should not be installed and should be left inactive, press [0/Prog] to bypass the new device.



Ensure that the correct device type is selected for each point. Incorrectly specified device types can cause multiplex devices to malfunction or fail to operate.

All inputs are configured to use Point Function 10 as they are added. Points added during auto programming are configured for the following operation:

Point Function 10 (Fire Alarm, Fast Response, Non-silenceable, Not Local-only)

Open Status = Trouble

Output Zone 9

Alarm Verify = NO

Latching = YES

The programming of input points can be changed when auto programming completes using the input-programming menu.

When I/O modules are added during auto programming, the relay (second point) is configured to activate on any alarm, non-silenceable (Zone 63). This can be changed when auto programming completes by using the output-programming menu.

The FPD-7024 performs some basic error checks when new devices are added. The following errors can be shown during the process of adding a device:

```
ADDRESS ERROR #
AT ADDRESS xxx
```

In the previous message, # is replaced by a code number and xxx is replaced by the affected address that indicates the type of error. Refer to *Table 26* for code numbers and corresponding error message descriptions.

Table 26: Auto Programming Error Messages

Code	Error	Description
1	New point is under an existing point	The new point is in the space required for an existing multi-address device. This is checked when auto programming first starts.
2	Point overlaps existing point	There are already devices configured at one of the addresses required for the new multi-point device.
3	Point is at an illegal address	The addresses at which multi-address devices can be installed are restricted. Refer to <i>Table 9</i> on page 15 or the specific device's installation instructions for details.
4	Too many multiplex relays	Only 20 input output devices can be supported on a given bus.

When the point adding operation completes, the FPD-7024 shows for five seconds the total number of points that were added to the control panel. Confirm that the number of devices added matches the expected number.

```
AUTO PROGRAM
xxx POINTS ADDED
```



If a new device is not detected on the bus during the point adding operation, the device does not operate and does not generate trouble conditions even if it remains connected to the bus.

When the point adding operation completes, the display shows the total number of points on the system (xxx is the total number of points, not devices).

```
AUTO PROGRAM
xxx MUX POINT
```

Confirm that the system shows the exact number of points expected. Points that are not included in the total count do not operate and do not generate trouble conditions.

After the count of total points appears for approximately 10 sec, the FPD-7024 restores the multiplex system to normal operation. This process takes approximately 50 sec and the following message appears during the restoral process:

```
AUTO PROGRAM
RESTORING
PLEASE WAIT...
```



As with any programming change to a system, test the system for proper operation before returning it to service. At least test each added multiplex point after auto programming completes. Test according to NFPA 72.

5.9.5 Removing MUX Devices



Shortcut: 0-PROG, 9-PROGRAM MUX 1- MUX EDIT

To remove a previously programmed multiplex device, use the MUX Edit feature.

```
PROGRAM MUX
1- MUX EDIT
2- MUX PROGRAM
3- BUS TYPE
4- AUTO PROGRAM
```

From the Program MUX menu, press [1] to select MUX Edit.

The following window appears:

```
DEVICE TYPE (__)
0- NO DEVICE
2- SINGLE INPUT
3- I/O MODULE
4- MUX SMOKE
5- SMOKE W/FRZ
6- DUAL INPUT
7- OCTAL INPUT
```

```
Description..... Model
0- NO DEVICE
2- SINGLE INPUT ..... D7044/M, D7045, FMM-7045,
                        D7052(Class A)
3- I/O MODULE ..... D7053
4- MUX SMOKE ..... D7050, D7050TH, D343
5- SMOKE W/FRZ ..... Not Used
6- DUAL INPUT ..... D7052(Class B)
7- OCTAL INPUT..... D7042
```

Press [0/Prog] for No Device. Then enter the address for the point you wish to delete.

After the device is successfully deleted, you return to the Device Type (MUX Edit) sub-menu. An unsuccessful deletion results in an error message (see below) followed by the Device Type (MUX Edit) sub-menu.

ERROR –
DEVICE FAILED



If you remove one point of a dual point address (for example, a D7042 Eight Point Input Module), the second point (and subsequent points) at this address are also removed. For example, if the first point of a D7042 is removed, the remaining seven points are also removed.

6.0 Installation Guide for UL Listed Systems

6.1 FPD-7024 UL Listings

The FPD-7024 is UL Listed for the following:

- Commercial Fire Alarm (Type Service; Auxiliary, Local, Central Station, and Remote Station; Type Initiating: Automatic, Manual, Sprinkler Supervisory, and Waterflow), UL Standard UL864.

Install the control panel according to NFPA 72 for Commercial Fire installations.

6.2 Installation Considerations

Failure to install and program the control panel according to the requirements in this section voids the listing mark of Underwriters Laboratories, Inc.

- The standby battery capacity is 40 Ah @ 24 VDC.
- The total nominal existing must not exceed 1.25 A in standby or 4 A when in alarm.
- The control panel must be mounted indoors and within the protected area.
- Grounding must be according to article 250 of the NEC (NFPA 70).
- Points must be connected to UL Listed, compatible devices.
- The ground wire provided with the enclosure must be connected between the door and the enclosure using the supplied nuts.
- Do not program the ground start feature.
- Select Phone Monitoring if the digital alarm communicator transmitter (DACT) feature is used.

6.3 Programming the FPD-7024



The system must be tested after installation and after any re-programming, including programming performed by downloading.

When used in UL Listed installations, the control panel must conform to certain programming requirements. Section 6.3.1 and 6.3.2 contain a list of the required program entries and required accessories for specific UL Listed installations.

6.3.1 Commercial Fire Alarm (Central Station [DACT] and Local)

Required Accessories

At least one Bosch Security Systems, Inc. Model D285 Smoke Detector with a D287, D288, D292, or D293 Series Base; or another UL Listed compatible smoke detector.

At least one D432A Horn Strobe or D443 Bell (provides 85 dB for UL985 and NFPA 72 requirements; other UL Listed compatible devices with a voltage range of 20 to 31 VDC can be used) is required for this application and must be installed inside the protected area.

Four-wire detectors must be used with UL Listed power supervision devices. A compatible UL Listed four-wire detector is the Bosch Security Systems, Inc. D285 in a D292 or D293 Series Base. A compatible Listed relay is the Bosch Security Systems, Inc. D275.

All points must be used with the resistor provided.

Report Programming

Program non-supervisory and supervisory reports for those points used.

Program trouble reports.

Set AC Failure Report Delay for 25% of estimated standby time, or set to send a report at 25% depletion of battery capacity.

Set automatic test report frequency to occur at least every 24 hours.

Timer Programming

Program Auto Silence Time for not less than five minutes, or to "0" to disable auto-silence operation.

Point Programming

For fire points: open = trouble, latching.

Alarm Output Programming

Program notification appliance circuits to activate from the appropriate input points.

Communications Programming (if Used for Central Station Service)

Select a communication format compatible with the central station.

Enable monitoring of both phone lines.

6.3.2 UL Listed Accessory Devices

D132B Multi-use Reversing Relay Module

The D132B is a multi-purpose, fully configurable, smoke power-reversing module for activating detectors with local annunciation. The D132B operates both two-wire and four-wire circuits and

also works with Class A or Class B initiating circuits. An alarm latch connection is provided to allow an initiating loop to be held in alarm after the detector loop power is reversed to activate any sounders. The D132B does not affect compatibility between the FACP and detectors, or the FACP and

Notification Appliance Circuits (NACs). Refer to the *D132B Installation Guide* (P/N: 40895) for detailed installation instructions for the D132B module. One of the installation options shown in the D132B Installation Guide is also shown in *Figure 14*:

Figure 14: Wiring the D132B-Smoke Power Reversing Module

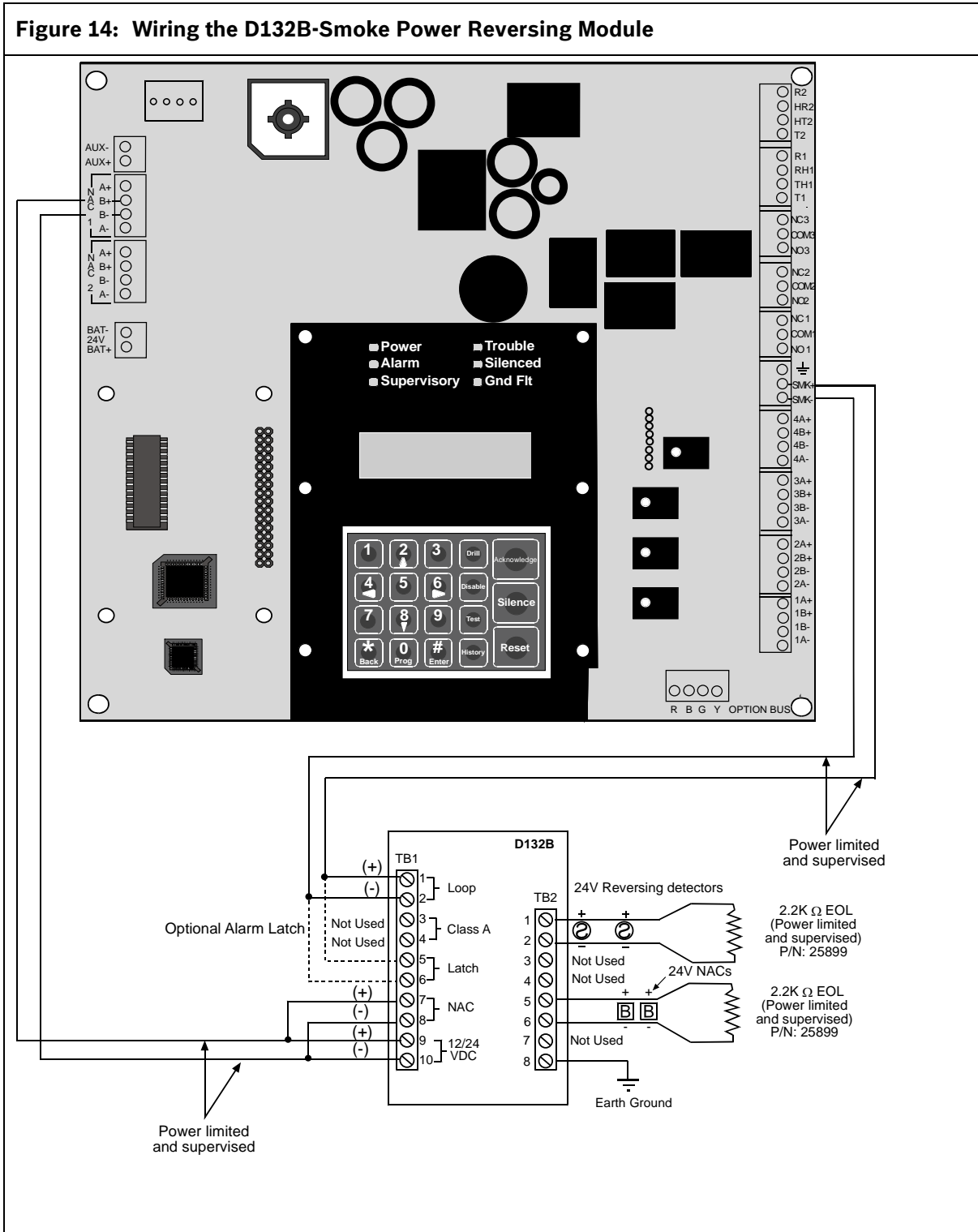

D185 Reverse Polarity Module

The D185 Reverse Polarity Module is a UL Listed module that connects the control panel with either a single set or a pair of leased telephone company (telco) lines in NFPA 72 remote station applications. It relays system alarm status information from the control panel to a monitoring station. The D185 operates with either 12 VDC or 24 VDC supply.

The module can signal alarm, trouble, and supervisory conditions. Refer to the *D185 Installation Manual* (P/N: 32906] for details. shows the module being used to signal alarm and trouble conditions only. With a third relay (available from the eight-relay expansion module) and an additional leased line, supervisory conditions can also be signaled.

In the example in *Figure 15*, Relay 1 must be programmed to operate on Alarm (Zone 63) and Relay 2 must be programmed to operate on Trouble (Zone 62). Program Input 4 to operate as a Supervisory point. Any alarm causes the voltage to the monitoring station to be interrupted. Placing the D185 in test mode causes a SUPERVISORY TROUBLE 4.

Figure 15: Wiring the D185

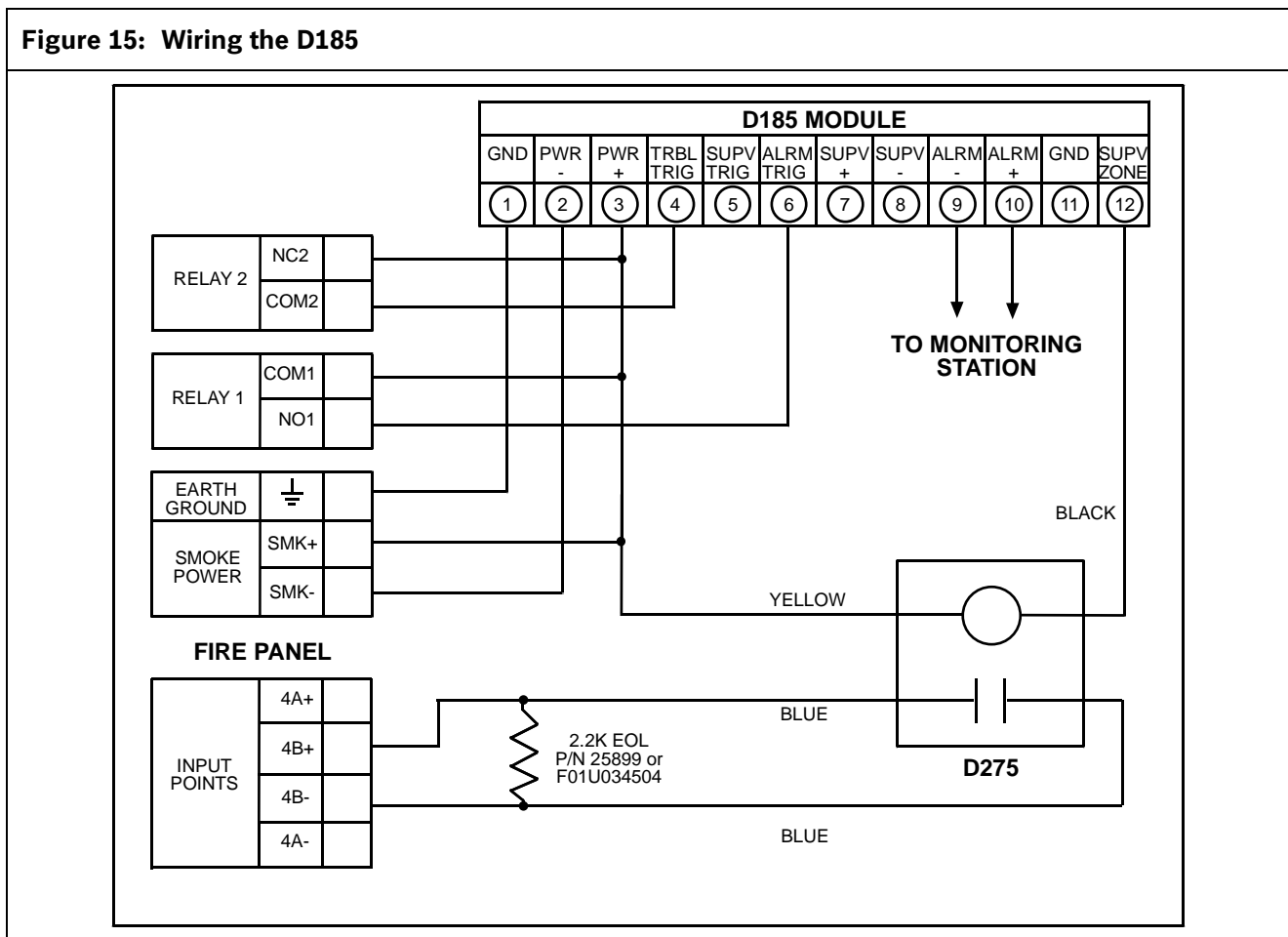

7.0 Fire Safety



No fire detection device or system is 100% foolproof.

This fire alarm system can provide early warning of a developing fire. Such a system, however, does not ensure protection against property damage or loss of life resulting from a fire. Any fire alarm system can fail to warn for any number of reasons (such as smoke not reaching a detector that is behind a closed door).



This system must be regularly tested (when installed, when modified, and at least annually thereafter) to ensure continued performance.

When considering detectors for residential applications, refer to NFPA Standard 72, The National Fire Alarm Code. This standard is available at a nominal cost from: The National Fire Protection Association, Batterymarch Park, Quincy, MA 02269.

7.1 Smoke Detector Layout

7.1.1 General Considerations

Proper location of detection devices is one of the most critical factors in a fire alarm system.

Smoke detectors should not be installed in dead air spaces or close to ventilating or air conditioning outlets because smoke can be circulated away from the detector. Locations near air inlets are favored.

Avoid areas subject to normal smoke concentrations such as kitchens, garages, or near fireplaces.

Do not install smoke detectors where normal area temperatures are above 100°F (38°C) or below 32°F (0°C).

Avoid areas of high humidity and dust concentrations.

Place the edge of ceiling mounted detectors no closer than 4 in. (10 cm) from any wall.

Place the top edge of wall-mounted detectors between 4 and 12 in. (10 and 30 cm) from the ceiling.

For exact mounting information, refer to the instructions provided with the smoke detectors.

7.1.2 Installing Family Residences

Providing a Fire Warning System: Most fire deaths occur in the home, especially during sleeping hours. The minimum level of protection requires smoke detectors to be installed outside of each separate sleeping area and on each additional story of the dwelling. Refer to *Figure 16*.



For added early warning protection, install detectors in all separate areas including the basement, bedrooms, dining room, utility room, furnace room, and hallways.

Figure 16: Smoke Detector locations in Residential Setting

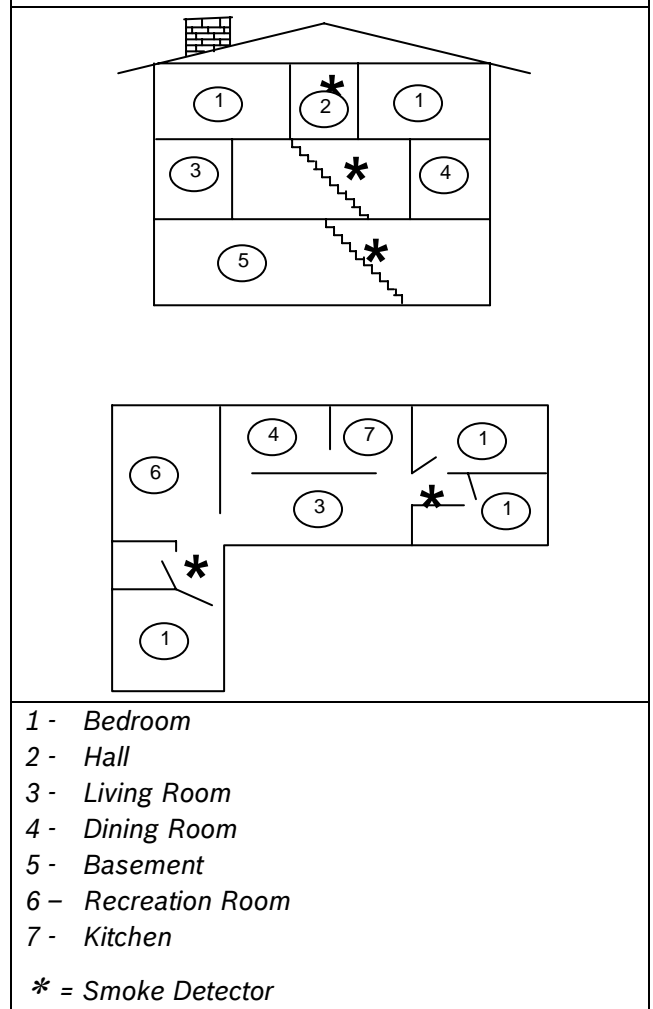

7.2 Having and Practicing an Escape Plan

A fire warning can be wasted unless the personnel planned in advance for a rapid and safe exit from the building.

Draw a floor plan of the entire building showing two exits from each sleeping area and two from the building. Since stairwells and hallways can be blocked during a fire, provide exits from sleeping area windows. Make copies of the plan and practice it with all personnel.

Arrange a meeting place outside and away from the building. Once out of the building, all occupants should immediately go to the pre-selected location to be accounted for.

Provide a barricade between personnel and fire, smoke, and toxic gases (such as closing all sleeping area doors before retiring).

Instruct children on opening their bedroom windows and exiting safely from the building. If exiting is not possible, teach them to stay at the open window and shout for help until it arrives.

If a fire alarm occurs after retiring, wake the children by shouting to them from behind your closed door. Tell them to keep their bedroom doors closed.

If the top of your bedroom door is uncomfortably hot, do not open it. There is most likely fire, intolerable heat, or smoke on the other side. Shout to all family members to keep their bedroom doors closed and to exit the building by alternate routes.

If the top of the door is not uncomfortably hot, brace the bottom of the door with your foot, and the top with one hand, then open the door about one inch. Be prepared to slam the door shut if there is any pressure against the door or if any hot air rushes in.

If there is no evidence of excessive heat or pressure, leave the room and close the door behind you. Shout appropriate instructions to all family members and immediately leave the building by the planned routes. If heavy smoke is present, drop to your hands and knees, or crawl to remain below the smoke level.

Appendix A: Abbreviations on Control Panel Display

Table 27: Abbreviations on Control Panel Display

Abbreviation	Definition	Abbreviation	Definition
3/1	3/1 Tone Burst (reporting format)	KPAD, KYPAD, KYPD	Keypad
4/2	4/2 Tone Burst (reporting format)	LRelay	Local Relay
@	Option Bus Address (1 - 16)	LOC	Local
ACTVTN	Activation	MACH	Answering Machine
A, ALRM	Alarm	M, MONI, MON	Monitor
ALT	Alternate	NAC	Notification Appliance Circuit
ANN, ANUN	Annunciator	NMBR, NUM	Number
BAT, BATT, BATTERY	Battery	NONSUP	Non-Supervisory
BX	Box (e.g. city box)	NORM, NRM	Normal
CATE	Catastrophe	OUT	Output
CDES, CODS, CDS	Codes	OVRC	Overexisting
CMPTR	Computer	PAS	Positive Alarm Sequence
COMM	Communicator	PHN, PHON	Phone
CONFIG	Configure	PROG, PRGMNG	Programming
DESCRIPTION	Description	PRGMMD	Programmed
DIG	Digit	PT, PNT	Point
DLY	Delay	PWR	Power
DRL, DRIL	Drill	REM, REMOT	Remote
D, DSBL, DISABL	Disable	RESPNS	Response
DSPLY	Display	RLY	Relay
EE	EEPROM	RPRT, RPT	Report
ERelay	Expander Relay	RST	Restore
EXP	Expander	SIL	Silence
FAIL	Failure	SMK	Smoke
F, FIR, FR	Fire	S, SUPERVISORY, SUPRVSRY, SUPV, SPV, SUPVSY	Supervisory
FLT	Fault	SHRT	Short
FRQNCY, FREQ, FREQUENCY	Frequency	SYS, SYSTM	System
FUNC	Function	T, TRBL, TRB, TROUB	Trouble
GRND	Ground	TST	Test
HI	High	VER	Version
HSTRY	History	W, WFLW, WTF	Waterflow
INIT	Initialize	ZN, ZON	Zone
IP	Internet Protocol address		

Appendix B: Control Panel Display Descriptions

Table 28: Control Panel Display Descriptions

FPD-7024 Panel Display Message	Panel Display Message Definition
FIRE DIRTY PT XX	A smoke detector with the Chamber Check [®] feature indicates a dirty chamber.
FIRE DSBL PT	Fire point is disabled from the keypad.
FIRE TRBL PT XXX	Trouble condition for specific points on the system. Check control panel wiring and field wiring for shorts or opens. Also check point programming to ensure the control panel knows what points belong on the system.
FIRE TROUBLE	General fire zone trouble message. Refer to the second line of display for more information.
INST FLT 4Z EXP	There is a missing FPD-7034 Four Zone Expander Board, or the expander appeared unexpectedly since the last time the system was powered.
INST FLT MX EXP	There is a missing D7039 MUX Expander Module, or the expander appeared unexpectedly since the last time the system was powered.
MONI DSBL PT	Monitor point is disabled from the keypad.
MONI TRBL PT XXX	Trouble with a monitor point occurred.
MUX BUS A FAILURE MUX BUS B FAILURE MUX CPU FAILURE	A wiring problem on Bus A or Bus B in Class B mode occurred. Check the wiring for shorts or opens. A CPU failure on the D7039 Expander Board occurred. Ensure that the D7039 is correctly installed on the header pins. If the message persists, call for service immediately.
SUPV DSBL PT	Supervisory point is disabled from the keypad.
SUPV TRBL PT XXX	Trouble with a supervisory point occurred.
SYSTEM TROUBLE	General trouble message. Refer to second line of the display for more information.
TRBL OPEN LNAC	A Local NAC circuit is open. Check the field wiring and the EOL resistor.
TRBL OPEN RNAC	A FPD-7038 Remote NAC circuit is open. Check the field wiring and the EOL resistor.
TRBL OPT BUS@XX	A wiring fault on option bus terminals 7 to 14, as well as specific address problems with option bus devices occurred. Check the wiring for the specific device address shown.
TRBL OVRC LNAC TRBL OVRC RNAC	An overexisting condition on one of the NAC circuits occurred. Check the field wiring on the notification appliances for shorts.
TRBL SHRT LNAC	A short on the Local NAC circuit occurred.
TRBL SHRT RNAC	A short on the FPD-7038 Remote NAC circuit occurred.
TROUBLE AC FAIL	AC power failure to the control panel. Check the circuit breaker or fuse for AC power problem.
TROUBLE ANN	Trouble with one or more annunciators connected to the control panel.
TROUBLE COMM FLT	A communicator problem occurred. Check the control panel's phone lines and programming for the communicator problem.
TROUBLE EEPROM	An EEPROM failure occurred. Call for service immediately.
TROUBLE EXP	A FPD-7034 Four Zone Expander board problem occurred. Ensure that the FPD-7034 is properly connected to the FPD-7024 PCB.
TROUBLE GRND FLT	A ground fault problem occurred. Ensure that no control panel wiring is shorted to the earth ground.
TROUBLE KPAD@XX	A specific keypad address failure occurred. Check the keypad's wiring and address settings.
TROUBLE LOW BATT	The control panel's battery charger is not working, or the backup batteries are missing.
TROUBLE MUX CLASS A	A failure on the MUX wiring in Class A mode occurred. Check the wiring for shorts or opens.
TROUBLE PHONE	A problem with the control panel's phone lines occurred. Check the phone wiring and line monitor programming.
TROUBLE RELAY@XX	One of the control panel's auxiliary relays might be shorted.
TROUBLE SMK PWR	A short on the smoke power terminals 24 and 25 occurred.
WFLOW DSBL PT	Waterflow point is disabled from the keypad.
WFLW TRBL PT XXX	Trouble with a waterflow or sprinkler point occurred.

Appendix C: Reporting Summary for Fire Communicator

Table 29: Reporting Summary for Fire Communicator

Report	Index	Default Values		Alternate Default		3/1	BFSK	SIA	Contact ID	Modem IIIa ²
		4/2 digit 1	4/2 digit 2	4/2 digit 1	4/2 digit 2					
POINT FIRE ALARM	0	0	p	0	p	0	z0	FAz	1 110 00 zzz	refer to Table 28
POINT WATERFLOW ALARM	1	0	p	0	p	0	z0	SAz	1 113 00 zzz	refer to Table 28
POINT SUPERVISORY ALARM	2	0	p	0	p	0	z0	SSz	1 200 00 zzz	refer to Table 28
POINT MONITOR ALARM	3	0	p	0	p	0	z0	UAz	1 140 00 zzz	refer to Table 28
POINT FIRE TROUBLE	4	6	p	6	p	6	Fz	FTz	1 373 00 zzz	refer to Table 28
POINT WATERFLOW TROUBLE	5	(see #4)	p	(see #4)	p	(see #4)	Fz	STz	1 373 00 zzz	refer to Table 28
POINT SUPERVISORY TROUBLE	6	(see #4)	p	(see #4)	p	(see #4)	Fz	STz	1 373 00 zzz	refer to Table 28
POINT MONITOR TROUBLE	7	(see #4)	p	(see #4)	p	(see #4)	Fz	UTz	1 373 00 zzz	refer to Table 28
POINT FIRE DIRTY	8	(see #4)	p	(see #4)	p	(see #4)	Fz	FSz	1 385 00 zzz	refer to Table 28
POINT WATERFLOW DIRTY	9	(see #4)	p	(see #4)	p	(see #4)	Fz	FSz	1 385 00 zzz	refer to Table 28
POINT SUPERVISORY DIRTY	10	(see #4)	p	(see #4)	p	(see #4)	Fz	FSz	1 385 00 zzz	refer to Table 28
POINT MONITOR DIRTY	11	(see #4)	p	(see #4)	p	(see #4)	Fz	UTz	1 373 00 zzz	refer to Table 28
POINT FIRE DISABLE	12	B	p	5	p	B	Fz	FBz	1 571 00 zzz	refer to Table 28
POINT WATERFLOW DISABLE	13	(see #12)	p	(see #12)	p	(see #12)	Fz	FBz	1 571 00 zzz	refer to Table 28
POINT SUPERVISORY DISABLE	14	(see #12)	p	(see #12)	p	(see #12)	Fz	FBz	1 571 00 zzz	refer to Table 28
POINT MONITOR DISABLE	15	(see #12)	p	(see #12)	p	(see #12)	Fz	FBz	1 571 00 zzz	refer to Table 28
POINT FIRE ALARM RESTORE	16	3	p	2	p	3	Ez	FRz	3 110 00 zzz	refer to Table 28
POINT WATERFLOW RESTORE	17	(see #16)	p	(see #16)	p	(see #16)	Ez	SHz	3 113 00 zzz	refer to Table 28
POINT SUPERVISORY RESTORE	18	(see #16)	p	(see #16)	p	(see #16)	Ez	SRz	3 200 00 zzz	refer to Table 28
POINT MONITOR RESTORE	19	(see #16)	p	(see #16)	p	(see #16)	Ez	URz	3 140 00 zzz	refer to Table 28
POINT FIRE TROUBLE RESTORE	20	3	p	7	p	3	Ez	FJz	3 373 00 zzz	refer to Table 28
POINT WATERFLOW TROUBLE RESTORE	21	(see #20)	p	(see #20)	p	(see #20)	Ez	SJz	3 373 00 zzz	refer to Table 28
POINT SUPERVISORY TROUBLE RESTORE	22	(see #20)	p	(see #20)	p	(see #20)	Ez	SJz	3 373 00 zzz	refer to Table 28
POINT MONITOR TROUBLE RESTORE	23	(see #20)	p	(see #20)	p	(see #20)	Ez	UJz	3 373 00 zzz	refer to Table 28
POINT FIRE DIRTY RESTORE	24	(see #20)	p	(see #20)	p	(see #20)	Ez	FJz	3 385 00 zzz	refer to Table 28
POINT WATERFLOW DIRTY RESTORE	25	(see #20)	p	(see #20)	p	(see #20)	Ez	FJz	3 385 00 zzz	refer to Table 28
POINT SUPERVISORY DIRTY RESTORE	26	(see #20)	p	(see #20)	p	(see #20)	Ez	FJz	3 385 00 zzz	refer to Table 28
POINT MONITOR DIRTY RESTORE	27	(see #20)	p	(see #20)	p	(see #20)	Ez	UJz	3 373 00 zzz	refer to Table 28
POINT FIRE DISABLE RESTORE	28	3	p	2	p	A	Ez	FHz	3 571 00 zzz	refer to Table 28
POINT WATERFLOW DISABLE RESTORE	29	(see #28)	p	(see #28)	p	(see #28)	Ez	FHz	3 571 00 zzz	refer to Table 28
POINT SUPERVISORY DISABLE RESTORE	30	(see #28)	p	(see #28)	p	(see #28)	Ez	FHz	3 571 00 zzz	refer to Table 28
POINT MONITOR DISABLE RESTORE	31	(see #28)	p	(see #28)	p	(see #28)	Ez	FHz	3 571 00 zzz	refer to Table 28
SYSTEM IN TEST	40	F	1	3	3	F	FD	TS0	1 607 00 000	refer to Table 28
SYSTEM IN TEST RESTORE	41	E	1	3	7	E	ED	TE0	3 607 00 000	refer to Table 28
SILENCE	42	9	F	9	F	9	FD	KBuu	1 400 00 uuu	refer to Table 28

Table 29: Reporting Summary for Fire Communicator

FIRE DRILL	43	F	2	3	3	F	FD	FI0	1 607 00 000	refer to Table 28
FIRE DRILL RESTORE	44	E	2	3	7	E	ED	FK0	3 607 00 000	refer to Table 28
SYSTEM RESET	45	9	F	9	F	9	FD	ORuu	1 305 00 uuu	refer to Table 28
LOW BATTERY	46	F	9	6	9	F	F9	YT0	1 302 00 000	refer to Table 28
LOW BATTERY RESTORE	47	E	9	7	9	E	E9	YR0	3 302 00 000	refer to Table 28
AC FAIL	48	F	A	6	0	F	FA	AT0	1 301 00 000	refer to Table 28
AC FAIL RESTORE	49	E	A	7	0	E	EA	AR0	3 301 00 000	refer to Table 28
AUTO TEST	50	E	E	3	0	E	EE	RP0	1 602 00 000	refer to Table 28
OFF NORMAL AT TEST	51	F	D	3	3	F	FD	YX0	1 608 00 000	refer to Table 28
PHONE 1 TROUBLE	52	F	B	3	1	F	FB	LT1	1 351 00 000	refer to Table 28
PHONE 1 RESTORE	53	E	B	3	5	E	EB	LR1	3 351 00 000	refer to Table 28
PHONE 2 TROUBLE	54	F	C	3	2	F	FC	LT2	1 352 00 000	refer to Table 28
PHONE 2 RESTORE	55	E	C	3	6	E	EC	LR2	3 352 00 000	refer to Table 28
SYSTEM TROUBLE	56	F	D	3	3	F	FD	ET	1 300 00 ccc	refer to Table 28
SYSTEM TROUBLE RESTORE	57	E	D	3	7	E	ED	ER	3 300 00 ccc	refer to Table 28
MANUAL TEST	58	(see #50)	(see #50)	(see #50)	(see #50)	(see #50)	EE	RX0	1 601 00 000	refer to Table 28
DATA LOST	59	(see #56)	(see #56)	(see #56)	(see #56)	(see #56)	FD	RT0	1 354 00 000	refer to Table 28
EEPROM FAILURE	60	(see #56)	(see #56)	(see #56)	(see #56)	(see #56)	FD	UT18	1 307 00 018	refer to Table 28
EEPROM RESTORAL	61	(see #57)	(see #57)	(see #57)	(see #57)	(see #57)	ED	UJ18	3 307 00 018	refer to Table 28
SMOKE POWER FAULT	62	(see #56)	(see #56)	(see #56)	(see #56)	(see #56)	FD	YP0	1 320 00 000	refer to Table 28
SMOKE POWER RESTORE	63	(see #57)	(see #57)	(see #57)	(see #57)	(see #57)	ED	YQ0	3 320 00 000	refer to Table 28
REMOTE PROGRAMMING FAIL	66	F	D	F	D	F	FD	RU0	1 413 00 000	refer to Table 28
REMOTE PROGRAMMING SUCCESS	67	E	D	E	D	E	ED	RS0	1 412 00 000	refer to Table 28

Notes:

- c: system trouble condition code
 - p: programmable digit for each zone
 - u: user ID digit
 - z: zone digit
- Shaded items are not programmable

When the Modem IIIa² reporting format is used with a Bosch Security Systems, Inc. receiver, refer to *Table 30* for information about the receiver output.

Table 30: Modem IIIa² Reporting		
Report	Index	Receiver Output
POINT FIRE ALARM	0	dd/dd tt:tt ql ACCT aaaa FIRE ALARM +++ ACCT aaaa AREA=1 POINT=zzz
POINT WATERFLOW ALARM	1	dd/dd tt:tt ql ACCT aaaa FIRE ALARM +++ ACCT aaaa AREA=1 POINT=zzz
POINT SUPERVISORY ALARM	2	dd/dd tt:tt ql ACCT aaaa FIRE SUPRVISION +++ ACCT aaaa AREA=1 POINT=zzz
POINT MONITOR ALARM	3	dd/dd tt:tt ql ACCT aaaa FIRE ALARM +++ ACCT aaaa AREA=1 POINT=zzz
POINT FIRE TROUBLE	4	dd/dd tt:tt ql ACCT aaaa FIRE TROUBLE +++ ACCT aaaa AREA=1 POINT=zzz
POINT WATERFLOW TROUBLE	5	dd/dd tt:tt ql ACCT aaaa FIRE TROUBLE +++ ACCT aaaa AREA=1 POINT=zzz
POINT SUPERVISORY TROUBLE	6	dd/dd tt:tt ql ACCT aaaa FIRE TROUBLE +++ ACCT aaaa AREA=1 POINT=zzz
POINT MONITOR TROUBLE	7	dd/dd tt:tt ql ACCT aaaa FIRE TROUBLE +++ ACCT aaaa AREA=0 POINT=zzz
POINT FIRE DIRTY	8	dd/dd tt:tt ql ACCT aaaa ANALOG SERVICE +++ ACCT aaaa AREA=0 POINT=zzz
POINT WATERFLOW DIRTY	9	dd/dd tt:tt ql ACCT aaaa ANALOG SERVICE +++ ACCT aaaa AREA=1 POINT=zzz
POINT SUPERVISORY DIRTY	10	dd/dd tt:tt ql ACCT aaaa ANALOG SERVICE +++ ACCT aaaa AREA=1 POINT=zzz
POINT MONITOR DIRTY	11	dd/dd tt:tt ql ACCT aaaa FIRE TROUBLE +++ ACCT aaaa AREA=1 POINT=zzz
POINT FIRE DISABLE	12	dd/dd tt:tt ql ACCT aaaa COMMAND BYPASS +++ ACCT aaaa AREA=1 ID=uuu POINT=zzz
POINT WATERFLOW DISABLE	13	dd/dd tt:tt ql ACCT aaaa COMMAND BYPASS +++ ACCT aaaa AREA=1 ID=uuu POINT=zzz
POINT SUPERVISORY DISABLE	14	dd/dd tt:tt ql ACCT aaaa COMMAND BYPASS +++ ACCT aaaa AREA=1 ID=uuu POINT=zzz
POINT MONITOR DISABLE	15	dd/dd tt:tt ql ACCT aaaa COMMAND BYPASS +++ ACCT aaaa AREA=1 ID=uuu POINT=zzz
POINT FIRE ALARM RESTORE	16	dd/dd tt:tt ql ACCT aaaa FIRE ALM RESTOR +++ ACCT aaaa AREA=1 POINT=zzz
POINT WATERFLOW RESTORE	17	dd/dd tt:tt ql ACCT aaaa FIRE ALM RESTOR +++ ACCT aaaa AREA=1 POINT=zzz

Table 30: Modem IIIa² Reporting (continued)		
Report	Index	Receiver Output
POINT SUPERVISORY RESTORE	18	dd/dd tt:tt ql ACCT aaaa FIRE ALM RESTOR +++ ACCT aaaa AREA=1 POINT=zzz
POINT MONITOR RESTORE	19	dd/dd tt:tt ql ACCT aaaa FIRE ALM RESTOR +++ ACCT aaaa AREA=1 POINT=zzz
POINT FIRE TROUBLE RESTORE	20	dd/dd tt:tt ql ACCT aaaa FIRE TBL RESTOR +++ ACCT aaaa AREA=1 POINT=zzz
POINT WATERFLOW TROUBLE RESTORE	21	dd/dd tt:tt ql ACCT aaaa FIRE TBL RESTOR +++ ACCT aaaa AREA=1 POINT=zzz
POINT SUPERVISORY TROUBLE RESTORE	22	dd/dd tt:tt ql ACCT aaaa FIRE TBL RESTOR +++ ACCT aaaa AREA=1 POINT=zzz
POINT MONITOR TROUBLE RESTORE	23	dd/dd tt:tt ql ACCT aaaa FIRE TBL RESTOR +++ ACCT aaaa AREA=1 POINT=zzz
POINT FIRE DIRTY RESTORE	24	dd/dd tt:tt ql ACCT aaaa ANALOG RESTORE +++ ACCT aaaa AREA=1 POINT=zzz
POINT WATERFLOW DIRTY RESTORE	25	dd/dd tt:tt ql ACCT aaaa ANALOG RESTORE +++ ACCT aaaa AREA=1 POINT=zzz
POINT SUPERVISORY DIRTY RESTORE	26	dd/dd tt:tt ql ACCT aaaa ANALOG RESTORE +++ ACCT aaaa AREA=1 POINT=zzz
POINT MONITOR DIRTY RESTORE	27	dd/dd tt:tt ql ACCT aaaa FIRE TBL RESTOR +++ ACCT aaaa AREA=1 POINT=zzz
POINT FIRE DISABLE RESTORE	28	dd/dd tt:tt ql ACCT aaaa FIRE TBL RESTOR +++ ACCT aaaa AREA=1 POINT=zzz
POINT WATERFLOW DISABLE RESTORE	29	dd/dd tt:tt ql ACCT aaaa FIRE TBL RESTOR +++ ACCT aaaa AREA=1 POINT=zzz
POINT SUPERVISORY DISABLE RESTORE	30	dd/dd tt:tt ql ACCT aaaa FIRE TBL RESTOR +++ ACCT aaaa AREA=1 POINT=zzz
POINT MONITOR DISABLE RESTORE	31	dd/dd tt:tt ql ACCT aaaa FIRE TBL RESTOR +++ ACCT aaaa AREA=1 POINT=zzz
SYSTEM IN TEST	40	dd/dd tt:tt ql ACCT aaaa WALK TEST START +++ ACCT aaaa AREA=1 ID=uuu
SYSTEM IN TEST RESTORE	41	dd/dd tt:tt ql ACCT aaaa WALK TEST END +++ ACCT aaaa AREA=1 ID=uuu
SILENCE	42	dd/dd tt:tt ql ACCT aaaa SENSOR RESET +++ ACCT aaaa AREA=0 ID=uuu RELAY#=0
FIRE DRILL	43	dd/dd tt:tt ql ACCT aaaa FIRE WALK START +++ ACCT aaaa AREA=1 ID=uuu

Table 30: Modem IIIa² Reporting (continued)		
Report	Index	Receiver Output
FIRE DRILL RESTORE	44	dd/dd tt:tt ql ACCT aaaa FIRE WALK END +++ ACCT aaaa AREA=1 ID=uuu
OPEN RESET	45	dd/dd tt:tt ql ACCT aaaa SENSOR RESET +++ ACCT aaaa AREA=1 ID=uuu RELAY#=0
LOW BATTERY	46	dd/dd tt:tt ql ACCT aaaa BATTERY LOW
LOW BATTERY RESTORE	47	dd/dd tt:tt ql ACCT aaaa BATTERY RESTORE
AC FAIL	48	dd/dd tt:tt ql ACCT aaaa AC FAILURE
AC FAIL RESTORE	49	dd/dd tt:tt ql ACCT aaaa AC RESTORAL
AUTO TEST	50	dd/dd tt:tt ql ACCT aaaa TEST REPORT
OFF NORMAL AT TEST	51	dd/dd tt:tt ql ACCT aaaa TEST-OFF NORMAL
PHONE 1 TROUBLE	52	dd/dd tt:tt ql ACCT aaaa PHONE LINE FAIL +++ ACCT aaaa PHONE LINE=1
PHONE 1 RESTORE	53	dd/dd tt:tt ql ACCT aaaa PHONE RESTORAL +++ ACCT aaaa PHONE LINE=1
PHONE 2 TROUBLE	54	dd/dd tt:tt ql ACCT aaaa PHONE LINE FAIL +++ ACCT aaaa PHONE LINE=2
PHONE 2 RESTORE	55	dd/dd tt:tt ql ACCT aaaa PHONE RESTORAL +++ ACCT aaaa PHONE LINE=2
SYSTEM TROUBLE	56	dd/dd tt:tt ql ACCT aaaa EQUIPMENT FAIL +++ ACCT aaaa SDI=001 COND=ccc
SYSTEM TROUBLE RESTORE	57	dd/dd tt:tt ql ACCT aaaa EQUIP RESTORAL +++ ACCT aaaa SDI=001 COND=ccc
MANUAL TEST	58	dd/dd tt:tt ql ACCT aaaa TEST REPORT
DATA LOST	59	dd/dd tt:tt ql ACCT aaaa COMM FAIL +++ ACCT aaaa PHONE#=1
EEPROM FAILURE	60	dd/dd tt:tt ql ACCT aaaa EQUIPMENT FAIL +++ ACCT aaaa SDI=001 COND=18
EEPROM RESTORAL	61	dd/dd tt:tt ql ACCT aaaa EQUIP RESTORAL +++ ACCT aaaa SDI=001 COND=18
SMOKE POWER FAULT	62	dd/dd tt:tt ql ACCT aaaa EQUIPMENT FAIL +++ ACCT aaaa SDI=001 COND=3

Table 30: Modem IIIa² Reporting (continued)

Report	Index	Receiver Output
SMOKE POWER RESTORE	63	dd/dd tt:tt ql ACCT aaaa EQUIP RESTORAL +++ ACCT aaaa SDI=001 COND=3
REMOTE PROGRAMMING FAIL	66	dd/dd tt:tt ql ACCT aaaa RAM ACCESS FAIL
REMOTE PROGRAMMING SUCCESS	67	dd/dd tt:tt ql ACCT aaaa RAM ACCESS OK
Note: dd/dd tt:tt: date and time aaaa: account number uuu: user ID zzz: point ccc: numeric identifier		

When the Modem IIIa², SIA or Contact ID reporting formats are used, an additional numeric identifier is sent with system trouble messages that provide a specific indication of the particular fault. This identifier is also recorded in the history log. *Table 31* lists the numeric identifiers.

Condition	System Event	Condition	System Event
Option bus device at address 1 failed	2	Remote relay module 2 disabled by user	52
Option bus device at address 2 failed	3	Class A, Style 6 wiring failure on MUX bus	53
Option bus device at address 3 failed	4	MUX bus A (9-128) failed	54
Option bus device at address 4 failed	5	MUX bus B (129-255) failed	55
Option bus device at address 5 failed	6	MUX module processor failure	56
Option bus device at address 6 failed	7	Remote NAC module 1, output 1 wiring fault	57
Option bus device at address 7 failed	8	Remote NAC module 1, output 2 wiring fault	58
Option bus device at address 8 failed	9	Remote NAC module 1, output 3 wiring fault	59
Option bus device at address 9 failed	10	Remote NAC module 1, output 4 wiring fault	60
Option bus device at address 10 failed	11	MUX bus A (9-128) hardware failure	61
Option bus device at address 11 failed	12	MUX bus B (129-255) hardware failure	62
Option bus device at address 12 failed	13	NAC 1 disabled by user	63
Option bus device at address 13 failed	14	NAC 2 disabled by user	64
Option bus device at address 14 failed	15	Remote NAC module 2, output 1 wiring fault	65
Option bus device at address 15 failed	16	Remote NAC module 2, output 2 wiring fault	66
DX4020 failed	17	Remote NAC module 2, output 3 wiring fault	67
EEPROM failure	19	Remote NAC module 2, output 4 wiring fault	68
Battery charger failure	20	Remote NAC module 3, output 1 wiring fault	69
Ground fault- wiring short	21	Remote NAC module 3, output 2 wiring fault	70
NAC 1 open wiring	22	Remote NAC module 3, output 3 wiring fault	71
NAC 2 open wiring	23	Remote NAC module 3, output 4 wiring fault	72
Remote NAC module 1 AC failure	24	Remote NAC module 4, output 1 wiring fault	73
Remote NAC module 2 AC failure	25	Remote NAC module 4, output 2 wiring fault	74
Remote NAC module 3 AC failure	26	Remote NAC module 4, output 3 wiring fault	75
Remote NAC module 4 AC failure	27	Remote NAC module 4, output 4 wiring fault	76
NAC 1 shorted wiring	28	Remote NAC module 1, output 1, disabled by user	77
NAC 2 shorted wiring	29	Remote NAC module 1, output 2, disabled by user	78
Remote NAC module 1 ground fault- short	30	Remote NAC module 1, output 3, disabled by user	79
Remote NAC module 2 ground fault- short	31	Remote NAC module 1, output 4, disabled by user	80
Remote NAC module 3 ground fault- short	32	Remote NAC module 2, output 1, disabled by user	81
Remote NAC module 4 ground fault- short	33	Remote NAC module 2, output 2, disabled by user	82
NAC 1 overcurrent	34	Remote NAC module 2, output 3, disabled by user	83
NAC 2 overcurrent	35	Remote NAC module 2, output 4, disabled by user	84
Remote NAC module 1 low battery	36	Remote NAC module 3, output 1 disabled by user	85
Remote NAC module 2 low battery	37	Remote NAC module 3, output 2 disabled by user	86
Remote NAC module 3 low battery	38	Remote NAC module 3, output 3 disabled by user	87
Remote NAC module 4 low battery	39	Remote NAC module 3, output 4 disabled by user	88
Communication path IP #1 fault	40	Remote NAC module 4, output 1 disabled by user	89
Multiplex bus outputs disabled by user	46	Remote NAC module 4, output 2 disabled by user	90
Dialer disabled by user	47	Remote NAC module 4, output 3 disabled by user	91
Relay 1 disabled by user	48	Remote NAC module 4, output 4 disabled by user	92
Relay 2 disabled by user	49	Four zone expander installation fault	93
Relay 3 disabled by user	50	MUX (DS9341) expander installation fault	94
Remote relay module 1 disabled by user	51	Communication path IP #2 fault	95

Appendix D: Programming Defaults List

PROG TIME

SYSTEM: Last date in EE 0000
AUTO TEST
TEST TIME: 0200
TEST FREQ: 1 to 4 hours
DAYLIGHT SAV: 2- enable

SECURITY

PINS

PROGRAMMER: 9876

USERS: User 1 = 1234
 User 2 = 0000

AUTHORITY

USER 1: 2
OTHERS: 0

PROG SYSTEM

TIMERS

SMOKE RESET: 6 seconds
AC FAIL DELAY: 6 hours
AUTO SILENCE: 0 minutes
DISPLAY RATE: 4x.25 = 1 second
AC LINE SYNCH 2 (60- Hz)

OPTION BUS

UPDATE BUS: Queries option buses and updates list of connected devices.

SETUP KEYPAD: 0

PIN REQUIRED:

LOCAL: 0- No
REMOTE: 1- Yes
REMOTE PGM 0- disable

PROG INPUTS

POINT NUMBER (1-4/5-8/9-255)
FUNCTION
 Point Function 1 = 1
 Point Function 2 = 2
 Point Function 3 = 3
 Point Function 4 = 4
 Point Function 5 = 5
 Point Function 6 = 6

Point Function 7 = 7
 Point Function 8 = 8
 Point Function 9 - 255 = 10
ALARM/TROUBLE: Trouble On Open
OUTPUT ZONE
 Point Zone 1 = 1
 Point Zone 2 = 2
 Point Zone 3 = 3
 Point Zone 4 = 4
 Point Zone 5 = 5
 Point Zone 6 = 6
 Point Zone 7 = 7
 Point Zone 8 = 8
 Point Zone 9 - 19 = 9
 Point Zone 20 - 39 = 10
 Point Zone 40 - 59 = 11 etc.

VERIFICATION: No
LATCHING: Yes

POINT FUNCTION (1 - 16)

	1-3, 5-10, 12-16	4	11
CONFIGURE	fire	water	supv
LOCAL ONLY	no	no	no
SILENCEABLE	no	no	no
LOOP REPSONSE	fast	16s	fast

PROG OUTPUTS

NACs

NAC #1:

CONFIGURATION Steady
:

ZONE ASSIGNS:

Zone A: 53
Zone B: 61
Zone C: 0
Zone D: 0

NAC #2:

CONFIGURATION Steady
:

ZONE ASSIGNS:

Zone A: 53
Zone B: 61
Zone C: 0
Zone D: 0

RNAC 1

Outputs 1, 2, 3, 4

Configuration: Steady
Zone Assignment:
Zone A: 53
Zone B: 0
Zone C: 0
Zone D: 0

RNAC 2

Outputs 1, 2, 3, 4

Configuration: Steady
Zone Assignment:
Zone A: 53
Zone B: 0
Zone C: 0
Zone D: 0

RNAC 3

Outputs 1, 2, 3, 4

Configuration: Steady
Zone Assignment:
Zone A: 53
Zone B: 0
Zone C: 0
Zone D: 0

RNAC 4

Outputs 1, 2, 3, 4

Configuration: Steady
Zone Assignment:
Zone A: 53
Zone B: 0
Zone C: 0
Zone D: 0

RELAYS

LOCAL RELAY #1

Zone A: 63
Zone B: 0
Zone C: 0
Zone D: 0

LOCAL RELAY #2

Zone A: 62
Zone B: 0
Zone C: 0
Zone D: 0

LOCAL RELAY #3

Zone A: 58
Zone B: 0
Zone C: 0
Zone D: 0

REMOTE 1 (D7035)

Relay 1/Zone A: 63
Relay 2/Zone A: 62
Relay 3/Zone A: 61
Relay 4/Zone A: 60
Relay 5/Zone A: 58
Relay 6/Zone A: 57
Relay 7/Zone A: 56
Relay 8/Zone A: 53

REMOTE 2

Relay 1 / Zone A: 1
Relay 2 / Zone A: 2
Relay 3 / Zone A: 3
Relay 4 / Zone A: 4
Relay 5 / Zone A: 5
Relay 6 / Zone A: 6
Relay 7 / Zone A: 7
Relay 8 / Zone A: 8

PROG ACCOUNTS

PHONE NUMBERS

PHONE 1, 2

NUMBER/IP: > (wait for dialtone)
FORMAT: 0 - Disable
ACCT NUMS: 0000
PHONE: 1 – 19D, 14A, 10PS

PHONE CONTROL

LINE 1, 2

MONITOR: No
DIALING TYPE: Pulse Only

REPORT STEERING

ALL SUB-MENU ITEMS: Phone 2 Back-up
 RING COUNT: 00
 COMM TRIES: 10
 MACH BYPASS: No
 ALTER COMM 0

PROG FORMATS

4/2 ZONE REPORT

0 - FIRE ALRM D1: 0
 1 - FIRE RSTR D1: 3
 2 - WATERFLOW D1: 0
 3 - SUPERVISE D1: 0
 4 - TROUBLE D1: 6
 5 - TRBL RSTR D1: 3
 6 - DISABLE D1: B
 7 - DSBL RSTR D1: 3
 8 - MORE

1- POINT 1 D2: 1
 2- POINT 2 D2: 2
 3- POINT 3 D2: 3
 4- POINT 4 D2: 4
 5- POINT 5 D2: 5
 6- POINT 6 D2: 6
 7- POINT 7 D2: 7
 8- POINT 8 D2: 8
 1- POINT 9 D2: 9
 2- POINT 10 D2: 0

4/2 RPT CODS

SYSTEM IN TST: F1
 SYS TEST RST: E1
 SILENCE: 9F
 FIRE DRILL: F2
 FIRE DRL RST: E2
 OPEN RST RPT: 9F
 LOW BATTERY: F9
 LOW BATT RST: E9
 AC FAILURE: FA
 AC FAIL RST: EA
 TEST REPORT: EE

OFF NORM TST: FD
 PHONE 1 TRBL: FB
 PN 1 TRB RST: EB
 PHONE 2 TRBL: FC
 PN 2 TRB RST: EC
 SYSTEM TROUB: FD
 SYS TRB RST: ED

BFSK RPT CDS

OFF NRM TST: FD
 OPEN/RESET: FD
 SILENCE: FD
 FIRE DRILL: FD
 FIR DRIL RSTR: ED

SIA SIL RPT

LEFT BYTE: 0x4B "K"
 RIGHT BYTE: 0x42 "B"

HISTORY DEFAULTS

ALT 4/2 CODES

4/2 POINT REPORTS

FIRE ALRM D1: 0
 FIRE RSTR D1: 2
 WATERFLOW D1: 0
 SUPERVISE D1: 0

TROUBLE D1: 6
 TRBL RSTR D1: 7
 DISABLE D1: 5
 DSBL RSTR D1: 2
 MONITOR D1: 0
 POINT 1 D2: 1
 POINT 2 D2: 2
 POINT 3 D2: 3
 POINT 4 D2: 4
 POINT 5 D2: 5
 POINT 6 D2: 6
 POINT 7 D2: 7
 POINT 8 D2: 8
 POINT 9 D2: 9
 POINT 10 D2: 0

4/2 RPT CODS

SYSTEM IN TST: 33
 SYS TEST RST: 37
 SILENCE: 9F

FIRE DRILL:	33
FIRE DRL RST:	37
OPEN RST RPT:	9F
LOW BATTERY:	69
LOW BATT RST:	79
AC FAILURE:	60
AC FAIL RST:	70
TEST REPORT:	30
OFF NORM TST:	33
PHONE 1 TRBL:	31
PN 1 TRB RST:	35
PHONE 2 TRBL	32
PN 2 TRB RST:	36
SYSTEM TROUB:	33
SYS TRB RST:	37

MULTIPLEX

MUX BUS TYPE: 2- CLASS B

Appendix E: Phone Monitor Troubleshooting

COMM FLT/DATA LOST

A common cause of this fault condition is failing to program Phone/IP Number 2 or Account Number 2 while some reports are directed to Phone/IP 2. Backup reports are still made to Phone/IP Number 1. This message warns the installer that Phone/IP Number 2 is not available if it is needed.

Other communications problems that can cause this condition include:

- Events occurring faster than the dialer can send them, which overflows the 32 event buffer,
- Programming errors such as missing phone numbers or account codes, over 100 Trouble reports in 24 hours, or
- Other problems contacting a receiver.

Check dialing type, format selection, phone numbers, account codes, phone line condition and tone programming (if tone burst formats are used). Refer to *Section 3.7 Communicator Operation* on page 31 for more information.

Trouble Phone

Some troubleshooting tips for phone monitor problems are listed below:

1. Use a voltmeter to measure the voltage present across each phone line (Tip to Ring) while the phone line is idle.



The voltage present during ringing for an incoming call can be over 100 VAC.”

This standby telco battery voltage is typically in the range of 30 VDC to 50 VDC, but any voltage above 5 VDC is accepted by the control panel.

The polarity of the voltage does not matter.

2. Check for other devices that might use the phone line, such as fax machines, credit card verifiers or PBX systems.



NFPA 72 requirements mandate a dedicated phone line for fire reporting.

If the devices cannot be removed, ensure they are wired so that the control panel's line seizure relay disconnects them when needed.

Measure the line voltage while these devices are in use. Ensure that it stays above 5 V.

3. Check for intermittent faults in the phone line.

Make a test call and confirm that the line is free of distortion and noise.

Temporarily swap Lines 1 and 2 on the control panel and check if the problem indication moves to the control panel's other phone line channel. If so, the phone line is causing the problem rather than the line monitor.

4. Confirm that the fault message is PHONE FAULT and not COM FAULT.

COM FAULT is often caused by failing to program a phone number or account number for Phone Number 2 while routing reports to Line 1, Backup Line 2.

If only one phone number is available for reporting, set report direction for all events to phone 1 only.

COM FAULT can also happen if one of the phone lines has telco battery voltage, but does not complete a call. Make test calls to the receiver(s) on both phone lines, listening for the receiver ACK tone.

5. Ensure that two phone lines are available.

In accordance with NFPA requirements, the Auto-test report is sent on a different phone line each time it is sent. If only one phone line is connected to the control panel, a COM FAULT is generated on every other test call.

Specifications

Table 32: Specifications.	
Temperature	Storage and Operating Temperature: +32°F to +120°F (0°C to +49°C)
Power	<p>Input Power: 220 V 50 Hz or 120 V, 60 Hz, 2.2 A</p> <p>Notification Appliance Circuit (NAC) Power: Each NAC has 24 VDC nominal, unfiltered power with up to 2.5 A capacity (but limited by overall 4.0 A capacity). Refer to <i>FPD-7024 NAC Compatibility List</i> (P/N: F01U010791) for compatible NAC devices.</p> <p>Auxiliary Power: 24 VDC nominal, unfiltered, 1.0 A</p> <p>Initiating Circuit (Smoke) Power: 24 VDC nominal, filtered, 1.0 A. Refer to <i>FPD-7024 Fire Alarm Control Panels</i> (P/N: F01U010790) for compatible smoke detection devices.</p> <p>Option Bus Power: 12 VDC nominal, 500 mA Optional Standby Batteries: Two 12 V (in series), 7 to 40 Ah</p>
Notification Appliance Circuits (NACs)	<p>Two on-board notification circuits NAC 1 and NAC 2. These are 24 V outputs for notification devices with up to 2.5 A capacity (but limited by overall 4.0 A capacity) on each circuit.</p> <p>Wire for standard Class B, Style Y or Class A, Style Z as needed.</p> <p>Configurable for patterns: steady, pulsing, California March, ANSI code 3, synchronized Wheelock, synchronized Gentex, and synchronized System Sensor.</p>
Relays	<p>Local Relays: The main control panel includes Three Form “C” relays. The relay contacts are rated at 5 A, 28 VDC. No over existing limiting is performed on the contacts of these relays. The default selection for the relays is to indicate general alarm and general system trouble and supervisory. By using point or zone mapping, they can be programmed to activate in a wide variety of conditions.</p> <div style="border: 1px solid black; padding: 5px; margin: 5px 0;">  <p>When a local relay is programmed for trouble it is energized in the normal state. This causes the common and normally-open terminals to be shorted when not in the trouble condition.</p> </div> <p>D7035 Remote Relay Module: The D7035 is an octal relay module that provides eight Form C relay outputs. It connects to the FPD-7024 through the option bus. The outputs are fully programmable, exactly as the local relays are programmed. Each output operates independently of the other seven to provide complete flexibility. Communication with the D7035 is supervised.</p> <p>Contact Rating: 5 A @ 28 VDC</p> <p>Number of Modules: two units maximum</p> <p>Wiring Requirements: Refer to <i>Section 2.2, Option Bus Wiring Requirements</i> on page 19.</p>

Index

A	
AC Fail Delay.....	43
AC Line Synch.....	45
Alarm/Trouble Status.....	48
Alternate 4/2 Codes.....	71
Appendix B	
Panel Display Descriptions.....	85
Appendix C	
Reporting Summary for Fire Communicator.....	86
Appendix D	
Programming Defaults List.....	93
Appendix E	
Phone Monitor Troubleshooting.....	97
Auto Silence.....	44
D	
Daylight Savings.....	41
Default EE.....	70
Display Rate.....	44
F	
Format Programming	
4/2 Report Codes.....	68
4/2 Zone Report.....	67
BFSK Report Codes.....	69
Prog Formats.....	67
H	
History	
Clear History.....	70
History Defaults.....	70
K	
Keypad	
Setup Keypad.....	45
L	
Latching.....	49
Loop Response.....	51
M	
Menu	
Main Menu	40
Programming Menu	40
<i>MUX</i>	
<i>Auto Program</i>	17, 74
Fast Programming.....	73
Multiplex Relays.....	57

MUX Bus Type.....	73
MUX Edit.....	71
MUX Program.....	72
Normal Programming.....	72
Program MUX.....	71
Removing MUX Devices.....	77
N	
Notification Appliance Circuit (NAC)	
Local NACs.....	53
Programming NACs.....	53
Remote NACs.....	55
O	
Option Bus	
Update Bus.....	45
Output Zones.....	48
P	
Panel Programming.....	40
Personal Identification Numbers	
Authority.....	42
Local PIN.....	46
PIN Required?.....	46
Program User PINs.....	42
Programmer PIN.....	41
Remote PIN.....	46
Phone	
Account Numbers.....	61, 62
Communication Tries.....	66
Dialing Type.....	64
Format.....	62
Machine Bypass.....	66
Monitor Line.....	64
Number.....	58
Phone Control.....	64
Phone Numbers.....	58
Report Steering.....	65
Ring Count.....	66
Tone.....	63
Point	
Assigning Point Functions.....	48
Configure.....	50
Local Only.....	51
Point Copy.....	52
Point Description.....	49
Point Function.....	50
Point Number.....	47
Program Accounts.....	58
Program Inputs.....	47
Program Outputs.....	53
Program System.....	43
Program Time.....	40

Program Timers.....43

Smoke Reset43

R

Relays

Local Relays55
 Multiplex Relays.....57
 Programming Relays55
 Remote Relays56

Remote Programming

Computer Phone.....58
 Enable/Disable.....47

S

Security41
 Silenceable.....51

T

Test

Automatic Test40
 Test Frequency.....41
 Test Time40

V

Verification.....49

Notes

Bosch Security Systems, Inc.
130 Perinton Parkway
Fairport, NY 14450-9199
(800) 289-0096

© 2010 Bosch Security Systems, Inc.
F01U008458-03



BOSCH