

# **FLD-2**

## **Failed Lamp Detector**

**USER MANUAL**

*Rail  
Signal  
Products*

---

**MICRO-AIDE**

*EVENT RECORDERS DATA LOGGERS SPEED MONITORS*

*CURRENT SENSORS ISOLATED MODEMS BATTERY MONITORS VOLTAGE MONITORS*

*LIGHT OUT DETECTORS CLOCK SYNCHRONIZERS WHISTLE DETECTORS LOCAL CONTROL PANELS*





## FLD-2 FAILED LAMP DETECTOR

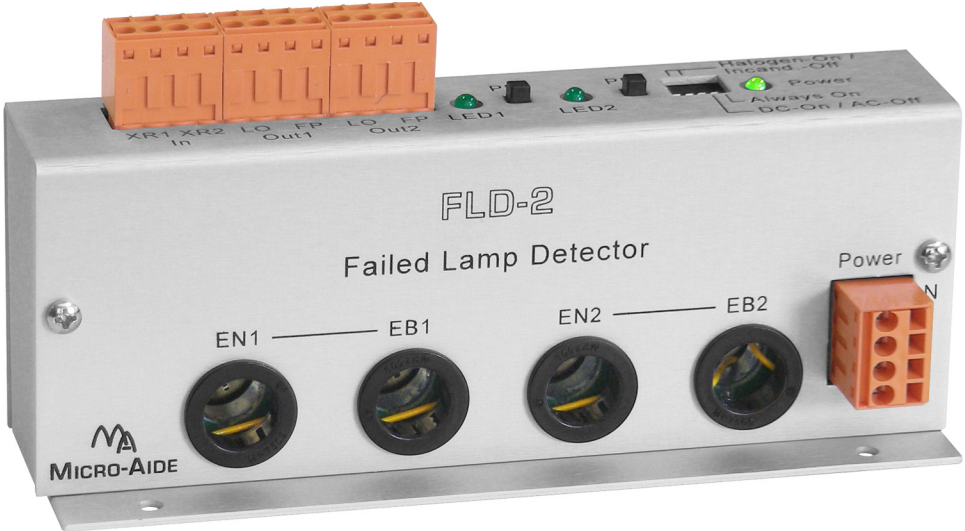

Revised: January 15, 2010

Copyright © 2009 by MICRO-AIDE Corporation

All rights reserved. No part of this document may be reproduced or transmitted in any form or by any means without the written permission of MICRO-AIDE Corporation.

The information in this document is subject to change without notice. MICRO-AIDE believes the information contained in this document to be accurate. However, MICRO-AIDE assumes no responsibility for any errors or omissions.

# TABLE OF CONTENTS

<b>CHAPTER 1</b>	<b>GENERAL DESCRIPTION</b>	
	Introduction . . . . .	1
	Key Features . . . . .	1
	Comparing FLD-2 Versions . . . . .	2
	About this Manual . . . . .	2
<b>CHAPTER 2</b>	<b>INSTALLATION AND SETUP</b>	
	Introduction . . . . .	3
	Unpacking . . . . .	3
	Installation Procedure . . . . .	3
	Location . . . . .	5
	Mounting . . . . .	5
	Site Preparation . . . . .	5
	Peripheral Equipment . . . . .	5
	Cabling . . . . .	6
	Power . . . . .	6
	Lamp Circuits . . . . .	6
	Input and Output Circuits . . . . .	6
	Applying Power . . . . .	6
	Calibration Procedure . . . . .	7
	Switch Settings . . . . .	7
	Calibration with All Lamps Flashing . . . . .	7
	Calibration with One Failed Lamp . . . . .	8
<b>CHAPTER 3</b>	<b>OPERATION</b>	
	Introduction . . . . .	11
	How to Operate an FLD-2 . . . . .	11
	Operating Modes . . . . .	11
	Reporting Failed Lamps . . . . .	11
	Measuring Flash Rate . . . . .	12
<b>CHAPTER 4</b>	<b>MAINTENANCE</b>	
	Introduction . . . . .	13
	Replacing the Power Fuse . . . . .	13
	Trouble-shooting Guide . . . . .	14
<b>APPENDIX A</b>	<b>TECHNICAL DATA</b>	
	Specifications . . . . .	15

**APPENDIX B BILLS OF MATERIAL**

FLD-2 Bill of Material . . . . .	.17
FLD-2 Subassemblies . . . . .	.17
PA85-0142/00 Processor PCB . . . . .	.17

# GENERAL DESCRIPTION

## Introduction

Since 1988 MICRO-AIDE has provided the rail signal industry with a broad range of event recording and ancillary products. Our ancillary products include a variety of devices that, in many cases, complement the use of our Event Recorders and Data Loggers. The Failed Lamp Detector (referred to as the FLD-2) is one of these products.

The FLD-2 has been redesigned for use in a broader range of applications, including those where an EOR relay is not available. More specifically, an FLD-2 can be used to detect lamp failures in installations that utilize Safetran's Solid State Crossing Controller (SSCC). However, compatibility with relay-based flashing control systems has been retained.

Unlike other products, the FLD-2 will operate as a standalone device. Its outputs do not require monitoring by the Analog Inputs of an Event Recorder. Its design incorporates non-intrusive Hall-Effect circuitry to monitor AC and DC currents. It is able to independently monitor two lamp circuits. Its four sensors allow for separate monitoring of the EB and EN circuit halves. The FLD-2 will automatically report a single lamp failure. It does so by asserting its Light Out (LO) output signal. The LO signal is fully compatible with the Digital Inputs of any Event Recorder or RTU. Another unique aspect of the FLD-2 is its Flash Pulse (FP) output signal. The FP signal pulses high and low as current is sensed in the EB and EN conductors. It too is compatible with the Digital Inputs of any Event Recorder. In SSCC-based systems that lack an EOR relay, the FP signal can be monitored by an Event Recorder (e.g., CWR-24E or CWR-72E). The recorder can then be configured to report the precise flash rate and duty cycle of the lamp circuit.

The FLD-2 is also easy to install and operate. A simple calibration procedure allows the FLD-2 to operate without further intervention. There are no recurring adjustments or alignment procedures to perform after the initial calibration is completed. Its design is based upon the use of digital-to-analog conversion circuitry and is therefore not prone to drift. All of the calibration derived operating parameters are stored in non-volatile memory within the FLD-2.

## Key Features

Listed below are some of the standard features included with every FLD-2.

- Single lamp failure detection for circuits with up to 12 lamps (nominal 25W lamps).
- Current sensing range is 7.5 to 30Adc ( 5 to 21Aac), incorporates true RMS sampling algorithm.

- Compensation for halogen and incandescent lamp types is provided.
- Automatic compensation for variations in the DC power source is provided.
- Separate monitoring of the EB and EN conductors allows the FLD-2 to provide a Flash Pulse output signal in systems that do not include an EOR relay.
- Complete isolation between the power terminals and lamp circuit conductors is insured by the passive nature of the FLD-2 circuit.
- BN, chassis and XR inputs have an isolation rating in excess of 3800Vdc.
- Installation is quite simple. Input wires are terminated in detachable, tension clamp terminals. Wire sizes as large as 12AWG can be used.
- Grommet lined holes in the FLD-2 are large enough to pass a standard sized .5" ring lug.
- Any BN battery source in the range of 10 to 36Vdc can power the detector.

## Comparing FLD-2 Versions

In 2009 the FLD-2 was substantially redesigned. The major points of distinction between the current and earlier models are listed below.

- The new design incorporates a total of four (as opposed to two) current sensors. This allows the new design to separately monitor the EB and EN conductors.
- Since the new design separately monitors the EB and EN conductors, it is able to provide a Flash Pulse (FP) output signal that toggles high and low when flashing is detected.
- Configuration and selection switches are directly accessible without the removal of any panel.

## About this Manual

This document is intended to provide the user with comprehensive, easy-to-read instructions on how to install, set up, operate and maintain the MICRO-AIDE FLD-2 Failed Lamp Detector. Wherever possible, step-by-step instructions have been included. In the event the user has questions about any of the described procedures the user should contact MICRO-AIDE for assistance. Additional copies of this manual are available upon request.

### **MICRO-AIDE CORPORATION**

685 Arrow Grand Circle

Covina, CA 91722

Tel: 626-915-5502 Fax: 626-331-9484

E-mail: support@micro-aide.com

**Note** The MICRO-AIDE Material Return and Limited Warranty policies can be found on the inside back cover of this manual.



# INSTALLATION AND SETUP

## Introduction

This chapter describes how to properly unpack, install and set up the FLD-2 prior to operation. It is advisable to review the Unpacking, Installation and Calibration sections before actually performing the procedures described in this chapter.

## Unpacking

Each FLD-2 is packed in a shipping carton that is properly sized for the product. Abundant packing materials are provided to minimize mechanical shock to the contents. Before opening the carton inspect it for damage. Damage to the carton should be noted. Carefully remove the product. It is advisable to save all packing materials in the event the product ever needs to be returned to MICRO-AIDE.

Inspect the product for visual damage. It should not be scratched, dented or deformed in any way. If it appears the product was damaged in shipment the responsible carrier should be notified immediately. MICRO-AIDE will assist the user in filing a claim in the event damage was sustained during shipment.

## Installation Procedure

The following sections describe the recommended Installation Procedure. Figure 1 and Figure 2 on page 4 illustrate elements that are common to most installations. The illustrations also depict the location of each connector used in the installation.

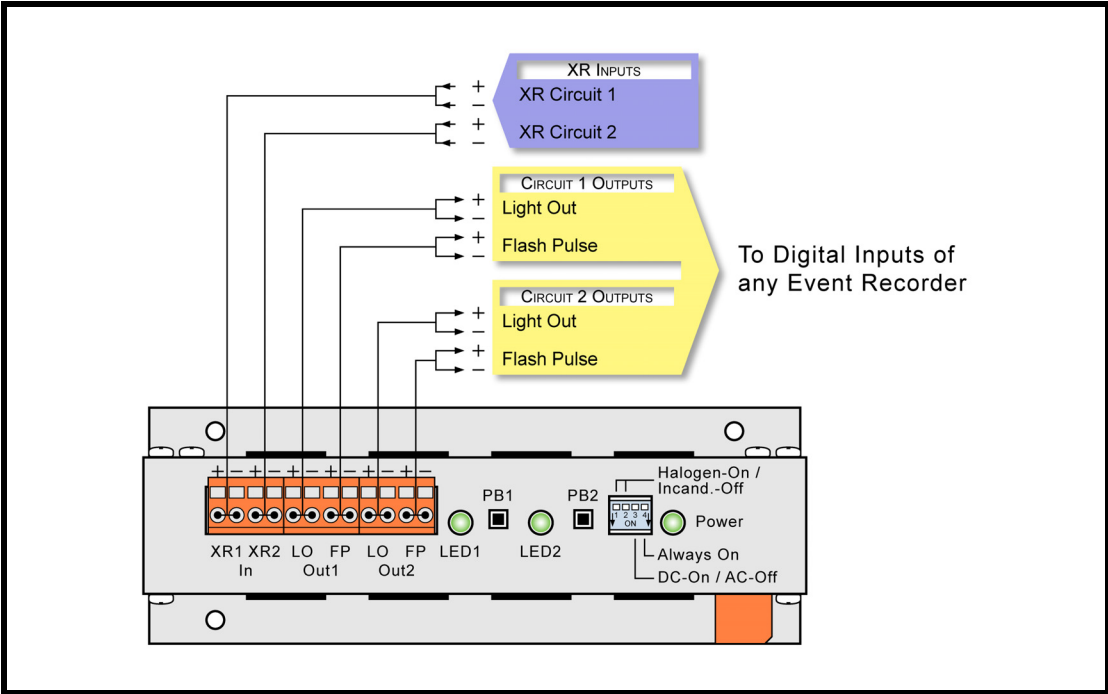

Figure 1 - Typical Installation - Top Panel View

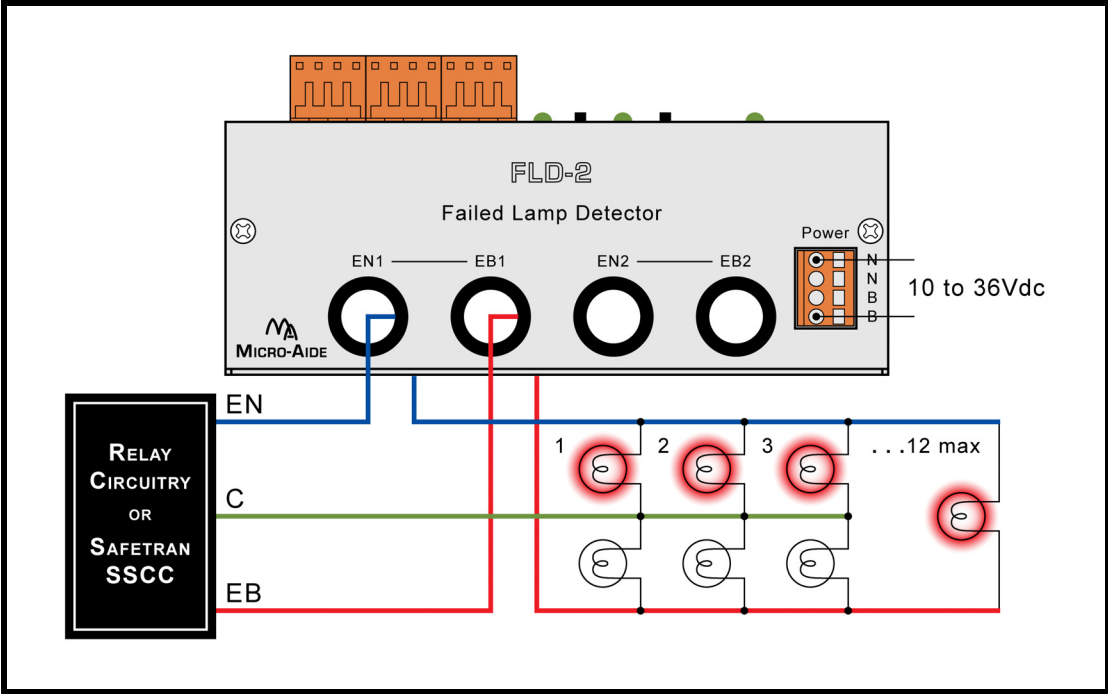

Figure 2 - Typical Installation - Front Panel View

## Location

The location where the FLD-2 is to be installed should comply with a few simple requirements. The ambient temperature near the detector should be in the range from -40°C to 72°C.

## Mounting

The FLD-2 can be mounted on top of a suitable shelf or secured to a back board. Although the FLD-2 utilizes magnetic field sensors, they are not affected by the earth's magnetic field. Consequently, the detector can be mounted in either a vertical or horizontal orientation. It is advisable to mount the FLD-2 away from large electric motors, machinery or conductors that might generate substantial magnetic fields.

## Site Preparation

The equipment location must have access to a stable 10 to 36Vdc power source. A pair of wires must be run from the power source to the location where the detector will be mounted. The FLD-2 wire ends must be stripped approximately 1/4". The stripped ends will be secured by tension clamp terminals located along the front panel of the detector. One wire must be connected to the positive voltage of the power source and the other wire must be attached to the return of the power source. The tension clamp terminals will accept wire sizes as large as 12AWG. The two wires must be properly secured to prevent damage.

The XR inputs and LO (Light Out) and FP (Flash Pulse) outputs use the same tension clamp terminals as those required by the power leads. Each wire should be tagged with its circuit identity. Each input cable or wire bundle should be secured to prevent damage to the connections at either end.

## Peripheral Equipment

The FLD-2 is designed to operate as a standalone device. It does not need to be connected to a PC for either setup, calibration or operation. For reporting and logging purposes the FLD-2 LO output can be connected to the Digital Inputs of an Event Recorder or RTU. In those installations where an EOR relay is not available the user may wish to connect the FLD-2 FP output to a Digital Input of an Event Recorder. This allows the Event Recorder to report flash rates and duty cycles. Cable connections between the FLD-2 and an Event Recorder or RTU should be kept to less than 20' in length.

## Cabling

Follow the steps listed below to complete the cabling installation.

**Tip** The power, input and output wires all terminate in tension clamp connectors that are detachable. The cable installation can be performed more easily if the female connectors are first detached from their male halves that remain secured to the FLD-2 circuit board. Figure 3 illustrates the proper use of the tension clamp lever.

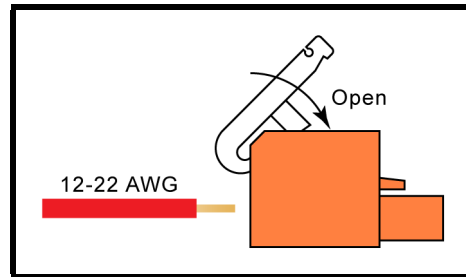

Figure 3 - Tension Clamp Lever

## Power

Ensure that the power is off at the power source. The two wires from the power source must be secured to either pair of tension clamp terminals labeled “B” and “N”, respectively.

## Lamp Circuits

The FLD-2 is designed to monitor current in both halves of a lamp circuit. As illustrated in Figure 2 on page 4, the EB and EN conductors are passed through holes in the unit. The unit is able to monitor a total of two lamp circuits. The FLD-2 performs an RMS conversion of the current sensing samples it acquires. Consequently, the direction of current flow through the FLD-2 is of no concern. The inside diameter of the protective grommet that lines each current sensing hole is .56". It is large enough to pass a straight angle (inline) .5" ring lug.

**Tip** The EB and EN conductors can be passed through the unit either front-to-back or back-to-front.

## Input and Output Circuits

The XR outputs and LO and FP outputs are each comprised of two polarity-sensitive conductors identified as positive (+) and negative (-). These conductors must be wired to terminals with matching polarities. The XR inputs are optically isolated from all other terminals. Each output conductor includes a 1.5KOhm series limiting resistor.

## Applying Power

Once the cabling is installed the power can be applied. The Power LED should illuminate whenever power is on. This completes the FLD-2 Installation Procedure. The Calibration Procedure can now be started.

## Calibration Procedure

The FLD-2 must be calibrated against the operational characteristics of the crossing. The characteristics that impact the FLD-2 include the number of lamps, lamp type and source voltage. At the conclusion of the Calibration Procedure data pertinent to these characteristics is stored in the non-volatile memory of the FLD-2. If power is lost indefinitely to the entire crossing installation, the FLD-2's calibrated operation will be fully restored immediately after power is reapplied. The FLD-2 can be calibrated and will operate properly in the presence of flashing rates in the range of 35 to 65 fpm.

## Switch Settings

Before the Calibration Procedure can be started, the piano-style switch must be set in accordance with the requirements of the crossing installation. The four-position switch is located along the top panel of the FLD-2. A description of each switch setting is listed in Table 1.





Lamp Type	Voltage	SW-1/2	SW-3	
Halogen	DC	On / On	On	
Incandescent	DC	Off / Off	On	
Halogen	AC	On / On	Off	
Incandescent	AC	Off / Off	Off	

Table 1 - Switch Setting Configurations

**Caution** Position 4 of the piano switch must always be left in the on position.

## Calibration with All Lamps Flashing

1. Verify that all of the lamps for Lamp Circuit 1 are installed.
2. Briefly press and then release a **single time** the pushbutton switch labeled “PB1”. Verify that the indicator labeled “LED1” is blinking approximately once per second.
3. Manually activate the crossing. LED1 continues to blink.
4. Verify that all lamps are flashing properly. After one second the XR input will be validated and LED1 will be on steady.
5. Wait approximately 10 seconds and LED1 will turn off automatically. This indicates that the FLD-2 has calibrated a reading for Lamp Circuit 1 with all lamps on.

6. Deactivate the crossing. This portion of the procedure has been completed.

## Calibration with One Failed Lamp

1. Disconnect two flashing lamps (i.e., not an end lamp), one each from the EB and EN halves of Lamp Circuit 1.
2. Briefly press and then release **twice in rapid succession** the pushbutton switch labeled “PB1”. Verify that the indicator labeled “LED1” is blinking approximately twice per second.
3. Manually activate the crossing. LED1 continues to blink.
4. Verify that only the disconnected lamps are not flashing. After one second the XR input will be validated and LED1 will be on steady.
5. Wait approximately 10 seconds and LED1 will turn off automatically. This indicates that the FLD-2 has calibrated a reading for Lamp Circuit 1 with a single lamp failure.
6. Deactivate the crossing. The procedure has been completed.

**Tip** Either sequence of the Calibration Procedure starts when PB1 is pressed. To immediately terminate the sequence, press PB1 once prior to the validation of the XR input. The LED will stop blinking and the FLD-2 will return to its normal operation.

**Tip** MICRO-AIDE recommends that the Calibration Procedure also be performed whenever lamps are replaced or changes are made to any of the lamp control systems.

The various steps that comprise the Calibration Procedure are also diagrammed in Figure 4 on page 9 and Figure 5 on page 10. If required, repeat the steps listed above for Lamp Circuit 2, making reference instead to PB2 and LED2.

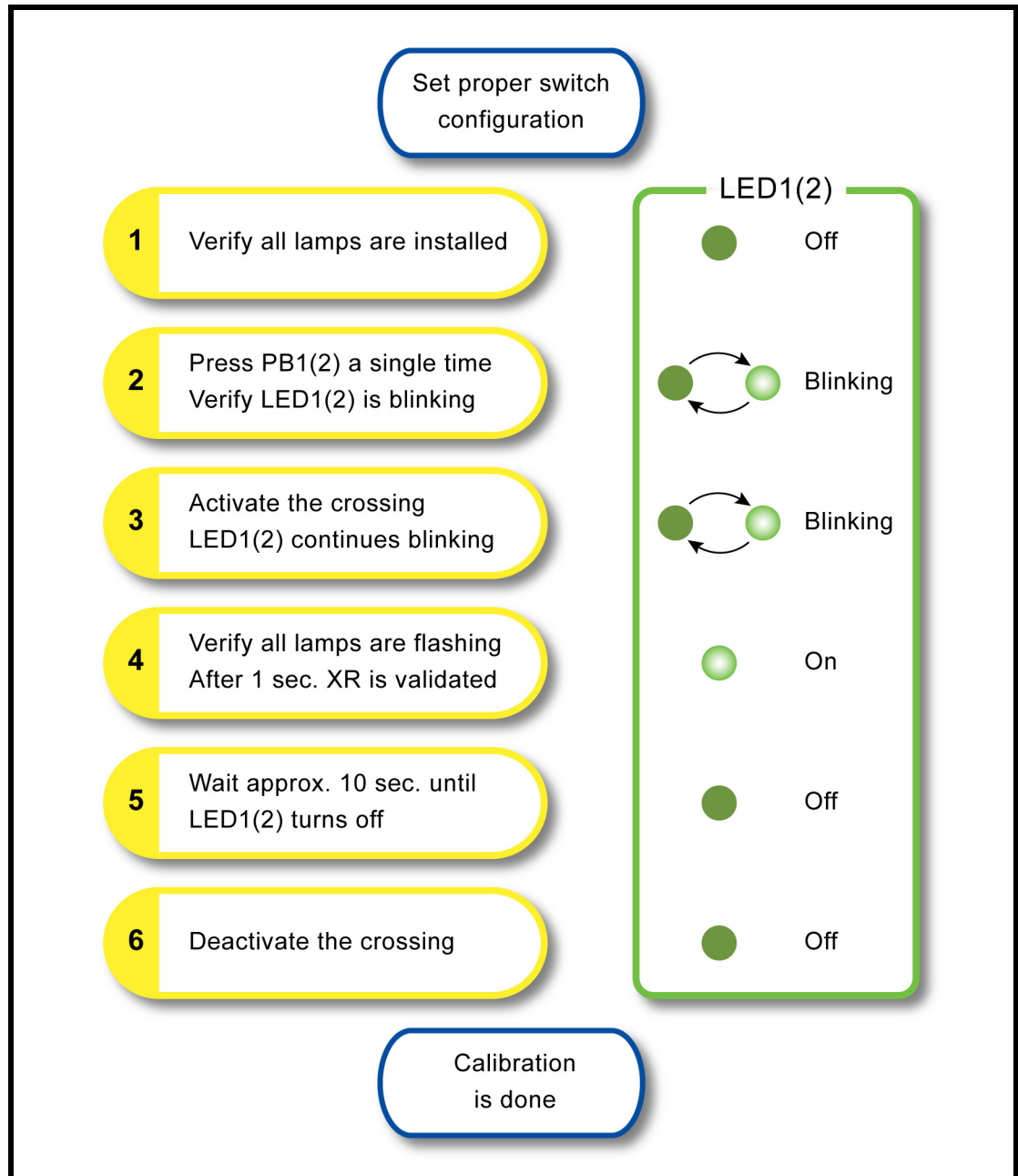

Figure 4 - Calibration Procedure - All Lamps Flashing

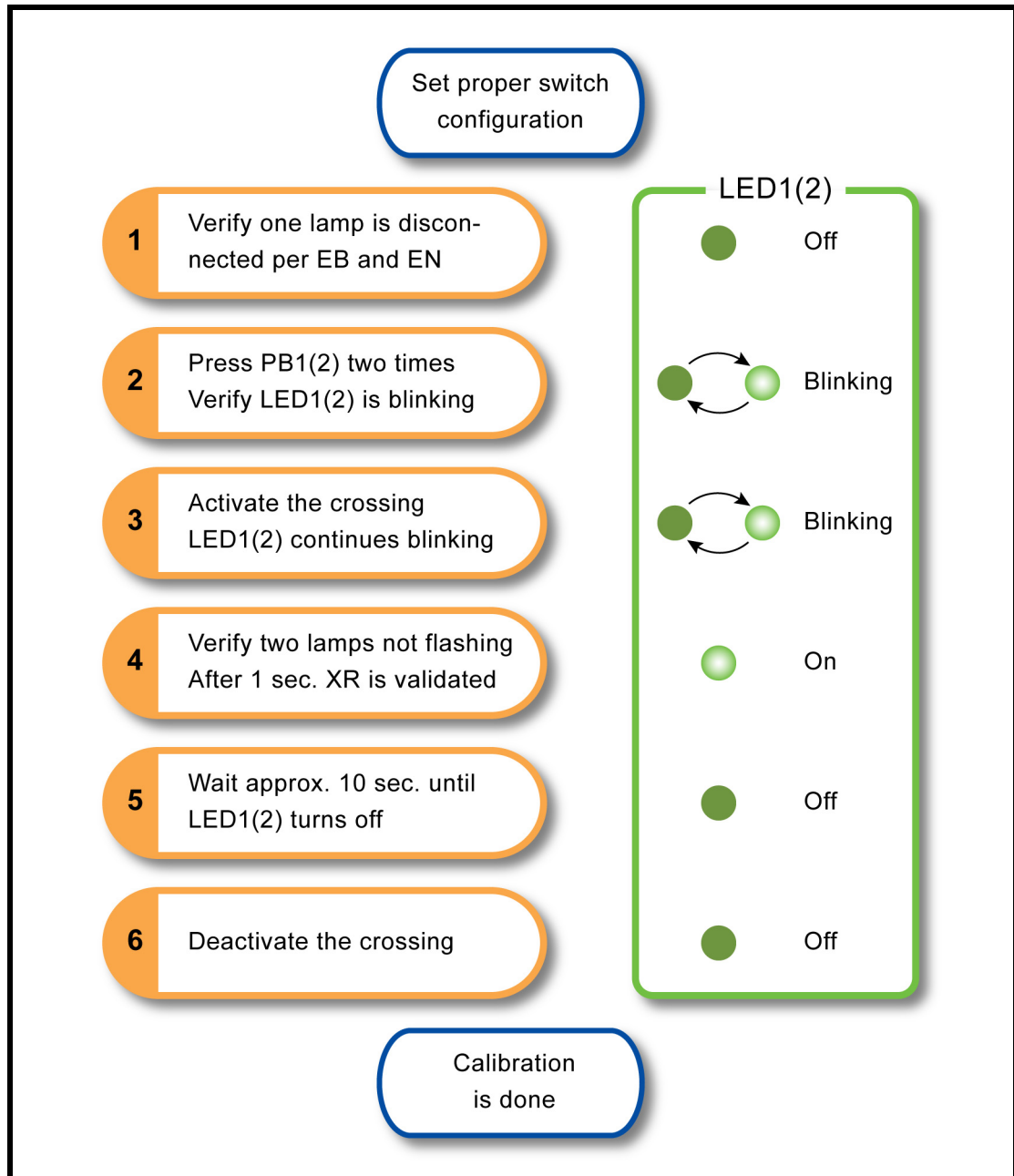

Figure 5 - Calibration Procedure - One Failed Lamp

**Note** If a problem arises during any portion of the Calibration Procedure the user should refer to the section entitled "Trouble-shooting Guide" on page 14. If the problem remains unresolved, the user should contact MICRO-AIDE customer service. Instructions on how to proceed will be offered. Material Return and Limited Warranty policies are described on the inside back cover of this manual.



# OPERATION

## Introduction

This chapter describes how the FLD-2 can be used to detect failed lamps at a typical crossing facility. Its use in conjunction with an Event Recorder or RTU is also described.

## How to Operate an FLD-2

As described in detail in Chapter 2, the FLD-2 can be used in a variety of configurations. As a standalone device, or as detector that operates as an element in a larger reporting system, its design is flexible and versatile. The following sections describe the primary operational aspects of the FLD-2. It is important to note that once installed and properly calibrated the FLD-2 operates automatically. The user should have no further need to intervene in the operation of the detector.

## Operating Modes

As listed in Table 1 on page 7, positions 1 and 2 of the piano switch are used to select either halogen or incandescent lamps. The FLD-2 is designed to monitor nominal 25W lamps as used in typical crossing facilities. The FLD-2 is able to compensate for changes in current flow as the source voltage changes. However, the current-versus-voltage relationship typical of halogen lamps is not shared by incandescent lamps. The FLD-2 utilizes the halogen/incandescent setting to adjust the amount of compensation by lamp type.

**Note** Current-versus-voltage compensation only occurs when the FLD-2 is used in DC mode.

## Reporting Failed Lamps

The Light Out (LO) signal is used by the FLD-2 to indicate that one or more lamps have failed in either the EB or EN half of the applicable lamp circuit. The plus and minus outputs of both LO signals are fully compatible with the Digital Inputs of any Event Recorder or RTU. The latter can be used to log an event and/or dispatch a failure notice to a maintenance center.

The LO signal is asserted only while the failure is being detected. That is, if a lamp has failed the FLD-2 will indicate the failure only while the crossing is active and the lamp circuit is drawing current. Accordingly, the LO signal will return to its off state when the crossing is once again idle and a failure will be indicated each time the crossing is active.

The operation of the LED indicators follow that of the LO signals. The LEDs will be off when the crossing is idle. Shortly after the XR has been validated as active, the applicable LED will turn on provided no lamp failure is detected. If a lamp failure is detected the LED will blink at a rate of approximately four times per second. The LED and FP signal behaviors are depicted in Figure 6.

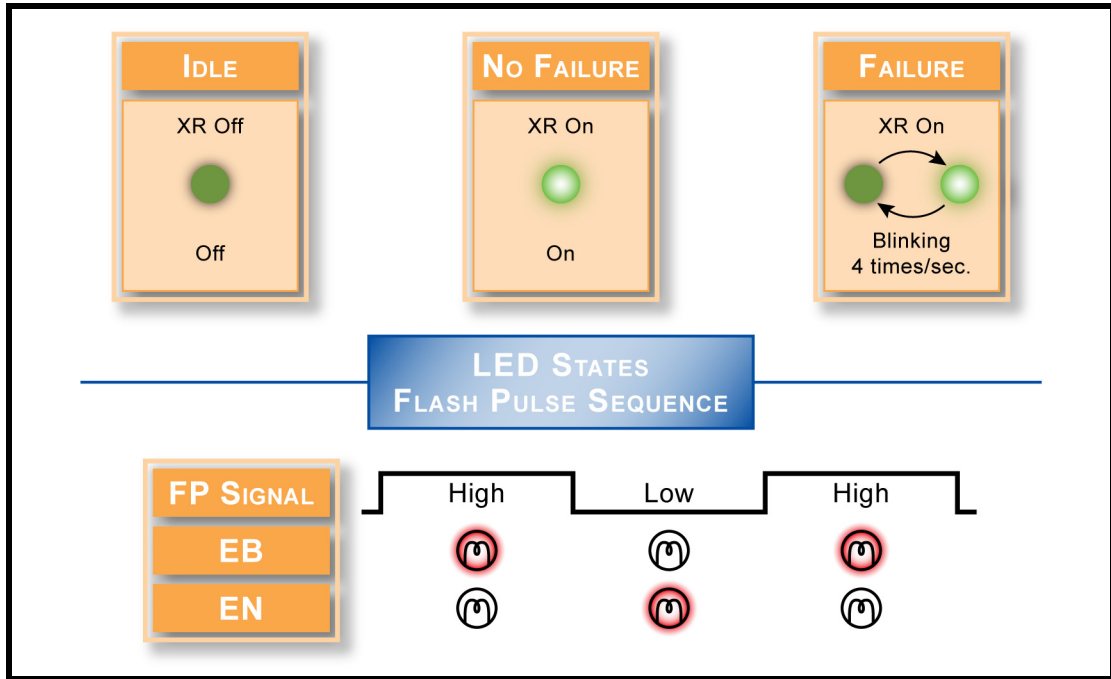

Figure 6 - LED and FP Behavior

## Measuring Flash Rate

Railroad operating procedures require that the flashing rate of crossing signals be periodically measured and reported. For installations that use an EOR relay this can be achieved by simply connecting contacts of the relay to Digital Inputs of an Event Recorder. All MICRO-AIDE recorders include extensive and precise flash rate measurement and reporting features.

An EOR relay is not available in installations where an SSCC (or comparable system) is used. However, the FLD-2 is able to provide an equivalent flashing signal. Both lamp circuits provide separate Flash Pulse (FP) signals. Their plus and minus outputs are fully compatible with any Event Recorder. The FP signal will pulse high (on) when current is flowing in the EB leg of the lamp circuit. It will pulse low (off) when current is flowing in the EN leg of the lamp circuit. The FP signals will operate in the range of 35 to 65 fpm. Except in extreme situations the FP signal will continue to pulse while a lamp failure is detected.

An important distinction exists when comparing the EOR relay and FLD-2 FP signals. The EOR relay signal indicates when voltage is applied to the lamp circuit. The FP signal indicates actual current flow through the lamp circuit. The former cannot indicate the presence of an open circuit, the latter can. Both can be used to report flash rate.

# MAINTENANCE

## Introduction

The primary purpose of this chapter is to describe the recommended trouble-shooting methods to be used with the FLD-2. It should be referred to if ever a questionable symptom arises during the operation of the detector.

The FLD-2 is designed to provide its user with many years of trouble-free operation. There are no user serviceable parts inside the detector. There are no consumable items or supplies that need to be replaced or replenished. The user may occasionally need to wipe dust away from the external surfaces of the detector. This should be done with a clean, dry cloth. The mechanical design of the chassis provides the internal electronic assembly with a nearly sealed environment. Due to the low power consumption of the detector ventilation holes are not required. The inside of the detector should remain clean indefinitely. Additionally, MICRO-AIDE printed circuit boards (PCBs) are sealed with a moisture and fungus resistant conformal coating.

## Replacing the Power Fuse

The only reason the user would need to access the inside of the FLD-2 is to check and/or replace the power fuse. Figure 1 on page 4 provides an illustration of the detector's front panel. To replace the power fuse follow the steps listed below.

1. Remove power by detaching the connector labeled "Power" located along the front panel of the detector.
2. Remove all of the input and output connectors.
3. With both lamp circuits de-energized, remove both sets of the EB and EN conductors.
4. Remove the detector from the equipment shelf or backboard.
5. Remove two 6-32 1/4" screws from each of the front and back panels of the top sheetmetal assembly. The screws in question are located near the horizontal center line of the detector and are nearest the left and right edges.

**Caution** Do not remove any of the other four screws located on the rear panel. They are used to secure the internal PCB to the top sheetmetal assembly.

6. The power fuse is rated at 1 A and conforms to the 2AG size standard. Before replacing the fuse the cause of the blown fuse should be ascertained and cleared if possible.

- After replacing the fuse reassemble the detector by performing the previous steps in reverse order.

**Caution** Electrostatic discharges can cause serious damage to electronic components. When handling circuitry inside the detector it is recommended that the user wear a wrist grounding strap.

## Trouble-shooting Guide

The following guide is provided to assist the user in resolving problems that may occur with the operation of the FLD-2. It can be especially helpful when attempting to operate the detector for the first time. Where multiple steps are indicated it is recommended that they be performed in the order listed.

If the user is unable to resolve the problem, MICRO-AIDE customer service technicians should be contacted. The user will be asked to state the problem, related symptoms, and indicate any operations or conditions that have a bearing on the problem. If available, the results of any diagnostic tests should be reported.

Symptom or Problem	Resolution
No indication of power	Verify 10 to 36Vdc at B and N power terminals Inspect fuse on internal PCB, refer to the procedure entitled "Replacing the Power Fuse" on page 13
LED does not blink when PB is pressed	Contact MICRO-AIDE for assistance
After starting calibration LED does not stop blinking	Verify XR is activated Verify XR + and - inputs are properly connected
LO signal does not report lamp failure(s)	Verify LED blinks at high rate when failure occurs; if not, perform both calibration procedures again, making sure one lamp is removed from EB and EN circuits Verify all lamps are nominal 25W Verify proper switch settings at FLD-2 Verify lamp voltage source is within range Verify LO + and - outputs are connected properly Verify Lamp Circuit1(2) is monitoring the correct EB1(2) and EN1(2) conductors
FP output is not reporting proper flash rate	Verify FP + and - outputs are connected properly Verify Event Recorder detection times are set correctly for expected flash rate Verify Event Recorder is enabled for flash reporting

*Table 2 - Guide to Trouble-shooting Techniques*

This completes the User Manual for the FLD-2. As an aid to the user two appendices have been provided. They include detailed specifications and a complete Bill of Materials.

Any comments the reader may have on how to improve this manual are welcomed. Comments should be forwarded to the Director of Marketing, MICRO-AIDE Corporation.

# TECHNICAL DATA

## Specifications

### Physical

#### Size

**Length:** 7.0"

**Height:** 3.4"

**Depth:** 2.5"

#### Weight

14 oz.

### Environmental

#### Storage

**Temperature:** -50°C to 85°C

**Humidity:** 0 to 95%, non-condensing

#### Operating

**Temperature:** -40°C to 72°C

**Humidity:** 0 to 95%, non-condensing

### Mounting

Shelf or back board mounting

### Construction

#### Chassis

Fully enclosed, anodized aluminum

Externally accessible switches, LEDs and connectors

#### Electrical

All components mounted on conformal coated, internal PCB

### Power

#### Voltage

**Range:** 10 to 36Vdc

#### Consumption

**Typical:** 1W

### Non-volatile memory

Saves all calibration parameters

Parameters are auto-restored when power is reapplied

### Isolation

#### Power

**Minimum:** 3800Vdc from B and N terminals to chassis and inputs

#### Lamp Circuit Inputs

**Minimum:** 5000Vdc to chassis or any terminal

### Inputs

#### Input Impedance

**Lamp Circuits:** infinite, uses Hall-effect circuitry for complete isolation

**XR:** minimum 10KOhms, opto-isolated

#### Range

**Lamp Circuits:** 7.5 to 30Adc (5 to 21Aac), per EB and EN circuit with lamps illuminated

**XR Input - On:** 5 to 40Vdc

**XR Input - Off:** 0 to 2Vdc

**Flashing:** 35 to 65fpm

### Capacities

#### Inputs

**Lamp Circuits:** 2, fully independent, AC or DC

Separate sensors for all EB and EN conductors

3 to 12 lamps per EB and EN circuit, 25W per lamp nominal

**XR:** 2 total, 1 per lamp circuit, ± pair

#### Outputs

**Light Out:** 2 total, 1 per lamp circuit, ± pair, 3 to 12mAdc

**Flash Pulse:** 2 total, 1 per lamp circuit, ± pair, 3 to 12mAdc

Pulses high and low with current flow

Range is 35 to 65fpm

### Connectors

#### Inputs and Outputs

Total 3, detachable, tension clamp, 4 terminals, 12 to 22AWG

#### Power

Single, detachable, tension clamp, 4-terminals, 12 to 22AWG

Dual B and N terminals

### Controls

#### Pushbutton Switches

**Quantity:** Total 2, 1 per lamp circuit

**Usage:** initiates calibration procedure

#### Piano Switch

**Quantity:** 1 with 4 positions

**Positions 1, 2:** selects halogen or incandescent lamps

**Position 3:** enables compensation for DC voltage fluctuation

**Position 4:** always on, for factory use only

### LED Indicators (3)

#### Power

Green, illuminates with power

#### Lamp Circuit 1 and 2

Green, flashes at various rates

**Off:** crossing is idle

**On:** crossing is active, no light failures

**Slow / Medium Flashing:** indicates calibration state

**Fast Flashing:** crossing is active, light failure detected

*MICRO-AIDE reserves the right to make changes, at its sole discretion, to any specifications listed herein.*



# BILLS OF MATERIAL

## FLD-2 Bill of Material

M-A Part No.	Description / MFG Part No.	Qty.
PA85-0142/00	PCB ASSEMBLY, PROCESSOR	1
H 8477/00	GROMMET, .75" I.D. KEYSTONE: 8477	8
JH231-131/00	LEVER, CONNECTOR, TENSION CLAMP WAGO: 231-131	2
JW170748/00	CONNECTOR, TENSION CLAMP, FEMALE, 4-POSITION WEIDMULLER: 1707480000	4
M 220449/00	SHEETMETAL, BOTTOM	1
M 220450/00	SHEETMETAL, TOP	1
ZMFLD-2	USER MANUAL, FLD-2	1

## FLD-2 Subassemblies

### PA85-0142/00 Processor PCB

M-A Part No.	Description / MFG Part No.	Qty.
P 85-0142/00	PCB, PROCESSOR, FLD-2	1
C .1MF/00	CAPACITOR, .1MF, 50V, CERAMIC	7
CE100MF/00	CAPACITOR, 100MF, 25V, AXIAL, ELECTROLYTIC NICHICON: TVX1E101MAA	1
CE220MF/00	CAPACITOR, 220MF, 50V, AXIAL, ELECTROLYTIC NICHICON: TVX1H221MCA	1
D 1N4004/00	DIODE, 400V 1N4004	3
D 1N5819/00	DIODE, SCHOTTKY, 40V, 1AMP 1N5819	1
DL3962-01/00	LED, GREEN, RIGHT ANGLE HP: HLMP-3962-010	3
F 225001/00	FUSE, 1 AMP LITTELFUSE: 225001	1
FH111501/00	FUSE CLIP LITTELFUSE: 111501	2
H PTX2515/00	TOROID, .062" GAP EASTERN COMPONENTS: P-TX251510-3C81-G.062	4
H TP-101/00	TEST POINT COMPONENTS CORP.: TP-101-10	3

<b>M-A Part No.</b>	<b>Description / MFG Part No.</b>	<b>Qty.</b>
JRICO-143/00	SOCKET, IC, 14-PIN OUPIIN: 8003-14T3	2
JW151366/00	CONNECTOR, MALE, 12-POSITION, RIGHT ANGLE WEIDMULLER: 1513660000	1
JW152206/00	CONNECTOR, MALE, 4-POSITION, STRAIGHT WEIDMULLER: 1522060000	1
L 20-102K/00	CHOKER, 1000UH ALLIED ELECTRONICS: APC20-102K	1
Q A1323/00	TRANSISTOR, HALL-EFFECT ALLEGRO: A1323EUA-T	4
Q PN2222A/00	TRANSISTOR, TO-92 PN2222	4
QRLM2574N/01	VOLTAGE REGULATOR, 5.0V, DIP NATIONAL: LM2574N-5	1
R 470 OHM/00	RESISTOR, 470 OHM, 5%, .25W	3
R 1K/03	RESISTOR, 1K, 1%, .25W	7
R 1.5K/00	RESISTOR, 1.5K, 5%, .25W	8
R 4.7K/01	RESISTOR, 4.7K, 5%, .25W	4
R 3.01K/00	RESISTOR, 3.01K, 1%, .25W	4
R 6.34K/00	RESISTOR, 6.34K, 1%, .25W	1
R 10K/00	RESISTOR, 10K, 5%, .25W	2
SD4PIANO/00	SWITCH, 4-POSITION, PIANO, DIP CTS: 195-4MST	1
SHB32-101/00	SWITCH, CAP, BLACK OMRON: B32-1010	2
SPB3F3152/00	SWITCH, PUSHBUTTON OMRON: B3F-3152	2
U 16F883/00	IC, PIC PROCESSOR, DIP MICROCHIP: PIC16F833-I/SP	1
ULOP490GP/00	IC, OP-AMP, QUAD, DIP ANALOG DEVICES: OP490GP	1
UOPC815/00	IC, OPTOCOUPLER, DIP SHARP: PC815	2



## **Material Return Policy**

In the event the customer identifies a malfunction in any product, call or write MICRO-AIDE and obtain a Return Material Authorization (RMA) number from the customer service department. Return the product to MICRO-AIDE, freight prepaid, with a note (in-warranty repair) or a purchase order (out-of-warranty) for the repair listing the following information:

- RMA number from MICRO-AIDE
- Return shipment address
- Name and telephone number of person familiar with the problem
- Brief description of the problem (include any printouts that may have a bearing on the problem)
- Method of payment for repair costs (out-of-warranty)
- Send product to the following address:

### **MICRO-AIDE CORPORATION**

685 Arrow Grand Circle

Covina, CA 91722

Tel: 626-915-5502 Fax: 626-331-9484

E-mail: [support@micro-aide.com](mailto:support@micro-aide.com)

## **Limited Warranty**

MICRO-AIDE warrants its products to be free from defects in material and workmanship for a period of five (5) years from the date of shipment. This warranty is in lieu of any other warranty, expressed or implied. In no event shall MICRO-AIDE be held liable for incidental or consequential damage resulting from (1) the use of any of its products, or (2) any alleged breach of this warranty provision. MICRO-AIDE's liability shall be limited to repairing or replacing, at its sole discretion, any defective product which is returned in accordance with the MICRO-AIDE Material Return Policy.

Product that has been subjected to abuse, misuse, alteration, accident, lightning damage, neglect or unauthorized installation or repair shall not be covered by this warranty. MICRO-AIDE reserves the right to make a final decision as to the existence of any failures and the cause of such failures. No warranty is made with respect to custom equipment or products produced to buyer's specifications except as mutually agreed upon in writing.

**MICRO-AIDE CORPORATION**

685 Arrow Grand Circle

Covina, CA 91722

Tel: 626-915-5502 Fax: 626-331-9484

E-mail: [support@micro-aide.com](mailto:support@micro-aide.com)