



See the possibilities

User's Manual

CV-L108CL

*3CCD High Speed Color
Line Scan Camera*

Document Version: 1.3
CV-L108CL_V.1.3_Dec2014

Notice

The material contained in this manual consists of information that is proprietary to JAI Ltd., Japan and may only be used by the purchasers of the product. JAI Ltd., Japan makes no warranty for the use of its product and assumes no responsibility for any errors which may appear or for damages resulting from the use of the information contained herein. JAI Ltd., Japan reserves the right to make changes without notice.

Company and product names mentioned in this manual are trademarks or registered trademarks of their respective owners.

Warranty

For information about the warranty, please contact your factory representative.

Certifications

CE compliance

As defined by the Directive 2004/108/EC of the European Parliament and of the Council, EMC (Electromagnetic compatibility), JAI Ltd., Japan declares that CV-108CL complies with the following provisions applying to its standards.

EN 61000-6-3 (Generic emission standard part 1)

EN 61000-6-2 (Generic immunity standard part 1)

FCC

This equipment has been tested and found to comply with the limits for a Class B digital device, pursuant to Part 15 of the FCC Rules. These limits are designed to provide reasonable protection against harmful interference in a residential installation. This equipment generates, uses and can radiate radio frequency energy and, if not installed and used in accordance with the instructions, may cause harmful interference to radio communications. However, there is no guarantee that interference will not occur in a particular installation. If this equipment does cause harmful interference to radio or television reception, which can be determined by turning the equipment off and on, the user is encouraged to try to correct the interference by one or more of the following measures:

- Reorient or relocate the receiving antenna.
- Increase the separation between the equipment and receiver.
- Connect the equipment into an outlet on a circuit different from that to which the receiver is connected.
- Consult the dealer or an experienced radio/TV technician for help.

Warning

Changes or modifications to this unit not expressly approved by the party responsible for FCC compliance could void the user's authority to operate the equipment.

Supplement

The following statement is related to the regulation on “ Measures for the Administration of the control of Pollution by Electronic Information Products “ , known as “ China RoHS “ . The table shows contained Hazardous Substances in this camera.

 mark shows that the environment-friendly use period of contained Hazardous Substances is 15 years.

重要注意事项

有毒，有害物质或元素名称及含量表

根据中华人民共和国信息产业部『电子信息产品污染控制管理办法』，本产品《有毒，有害物质或元素名称及含量表》如下。

部件名称	有毒有害物质或元素					
	铅 (Pb)	汞 (Hg)	镉 (Cd)	六价铬 (Cr(VI))	多溴联苯 (PPB)	多溴二苯醚 (PBDE)
棱镜	×	○	○	○	○	○
光学滤色镜	×	○	×	○	○	○
镜头座	×	○	○	○	○	○
连接插头	×	○	○	○	○	○
电路板	×	○	○	○	○	○
.....

○：表示该有毒有害物质在该部件所有均质材料中的含量均在SJ/T11363-2006规定的限量要求以下。
 ×：表示该有毒有害物质至少在该部件的某一均质材料中的含量超出SJ/T11363-2006规定的限量要求。
 （企业可在此处、根据实际情况对上表中打“×”的技术原因进行进一步说明。）



环保使用期限

电子信息产品中含有的有毒有害物质或元素在正常使用的条件下不会发生外泄或突变、电子信息产品用户使用该电子信息产品不会对环境造成严重污染或对基人身、财产造成严重损害的期限。

数字「15」为期限15年。

- Contents -

1.	General.....	5
2.	Standard composition.....	5
3.	Main features.....	5
4.	Locations and functions	6
5.	Connectors.....	7
5.1.	12-Pin Connector (Hirose).....	7
5.2.	Digital Output / Interface Connectors for Camera Link.....	7
5.3.	Input and output circuits.....	8
5.3.1.	Trigger input.....	8
5.3.2.	EEN / XEEN output (Exposure ENable).....	9
6.	Functions and Operation	10
6.1.	Basic functions	10
6.2.	Pixel Gain (flat-field) correction (PRNU correction).....	11
6.3.	Pixel black level correction (DSNU / FPN correction)	11
6.4.	Shading correction.....	12
6.5.	Binning.....	12
6.6.	Operation modes.....	13
6.6.1.	No-Shutter mode with Internal line rate generator	14
6.6.2.	No-Shutter mode with External Trigger	15
6.6.3.	Shutter-Select mode with Internal line rate generator.....	16
6.6.4.	Shutter-Select mode with External trigger	17
6.6.5.	Pulse Width Control (PWC) mode.....	18
6.6.6.	Auto Reset mode	19
6.7.	Scan rate and exposure time range.....	20
6.7.1.	Minimum cycle time of external trigger.....	20
6.7.2.	Minimum trigger pulse width.....	20
6.8.	Relationship between Trigger and LVAL	20
6.9.	Compatibility of trigger modes and functions	20
6.10.	Rear panel indicator.....	21
7.	Configuring the camera.....	22
7.1.	CV-L108CL Command list.....	22
8.	Functions listed alphabetically by command acronyms.....	26
8.1	Command AHRS - Request status after One-Push AWB.....	26
8.2	Command AL - Automatic Line Rate Reference Level	26
8.3	Command AR - Automatic Line Rate setting	26
8.4	Command ARST - Auto Reset Mode	26
8.5	Command AW - Activate One-push Auto White Balance (AWB) - Gain.....	26
8.6	Command AH - Activate One-push Auto White Balance (AWB) - Shutter.....	27
8.7	Command BA - Bit Allocation	27
8.8	Command BI - Binning (Horizontal only)	27
8.9	Command BL - Master Black Level	28
8.10	Commands BLR and BLB - Black level red and black level blue.....	28
8.11	Command EI - Interlocked R, G and B exposure	28
8.12	Command GA - Master Gain Level.....	28
8.13	Commands GAR and GAB - Gain level red and gain level blue.....	28
8.14	Command NK - Knee function enable/disable	28
8.15	Commands KSR, KSG and KSB - Knee slope for R, G and B.....	29
8.16	Commands KPR, KPG and KPB - Knee point for R, G and B.....	29
8.17	Command LR - Line Rate (Scan Rate)	29
8.18	Command PBC - Enable pixel black (FPN) correction.....	30
8.19	Command PBR - Run pixel black correction and store to user area.....	30
8.20	Command PER - Programmable exposure - Red	30
8.21	Command PEG - Programmable exposure - Green	30
8.22	Command PEB - Programmable exposure - Blue.....	31
8.23	Command PGC - Enable Flat-field correction (Pixel gain).....	31

8.24	Command PGR - Run Flat-field correction and store in user area.....	31
8.25	Command SDC - Select shading correction mode	31
8.26	Command SDR - Run shading correction	31
8.27	Command SDS - Request status after executing shading correction command	33
8.28	Command TG - Trigger Origin.....	33
8.29	Command TI - Trigger input.....	33
8.30	Command TP - Trigger polarity.....	33
8.31	Command TR - Trigger Mode.....	33
8.32	Command TS - Test pattern.....	34
8.33	Command WB - White Balance	35
8.34	Factory default settings	35
8.35	Serial communication	36
9	Camera Control Tool for CV-L108CL.....	37
9.1	Control Tool Windows.....	38
9.2	Camera Control Tool Interface	39
9.3	Using Camera Control Tool.....	41
10	External appearance and Dimensions	42
11	Specifications	43
11.1	Typical data	43
11.2	Spectral sensitivity.....	45
12	Appendix	46
12.1	Precautions.....	46
12.2	Typical Sensor Characteristics	46
12.3.	Caution when mounting a lens on the camera	46
12.4.	Exportation.....	46
12.5	References.....	46
	Change History.....	47
	User's Record.....	48

1. General

CV-L108CL is a 3CCD line scan camera using three 512 pixel line sensors mounted on a prism, for the R, G and B channels. It operates with a 40 MHz pixel clock, resulting in a maximum line rate of 70,922 lines per second.

The camera outputs digital data in 3 x 8 bits or 3 x 10 bits format via Camera Link. The camera is configured by software through the serial communication port of the Camera Link interface, or via RS-232C through a 12-pin Hirose connector.

The camera accepts F-mount lenses and can optionally be ordered with a P-mount (M42x1) lens adapter

The latest version of this operation manual can be downloaded from www.jai.com .

The latest camera control tool for the CV-L108CL can be downloaded from www.jai.com .

For camera revision history, please contact your local JAI distributor

2. Standard composition

The standard camera composition consists of the camera body. A lens is not included with the delivery.

The camera is available in the following versions:

CV-L108CL with F-mount

3. Main features

- 3CCD line scan camera with 512 pixel resolution
- Dichroic RGB beam splitter prism
- 70,922 lines per second scan rate
- 40 MHz pixel clock
- 3 x 8 bits or 3 x 10 bits output through Camera Link interface
- F-mount lens adapter
- Flat-field correction. Two point pixel-by-pixel compensation on each RGB channel
- Flat shading compensation
- Color shading compensation
- One-push white balance
- Pixel binning
- Test pattern generator(color bar, gray, white) for set-up and troubleshooting
- Electronic shutter (for selected modes)
- Built-in diagnostics
- Short ASCII commands for set-up via RS 232C or Camera Link
- Setup by Windows 2000/XP/Vista software

4. Locations and functions

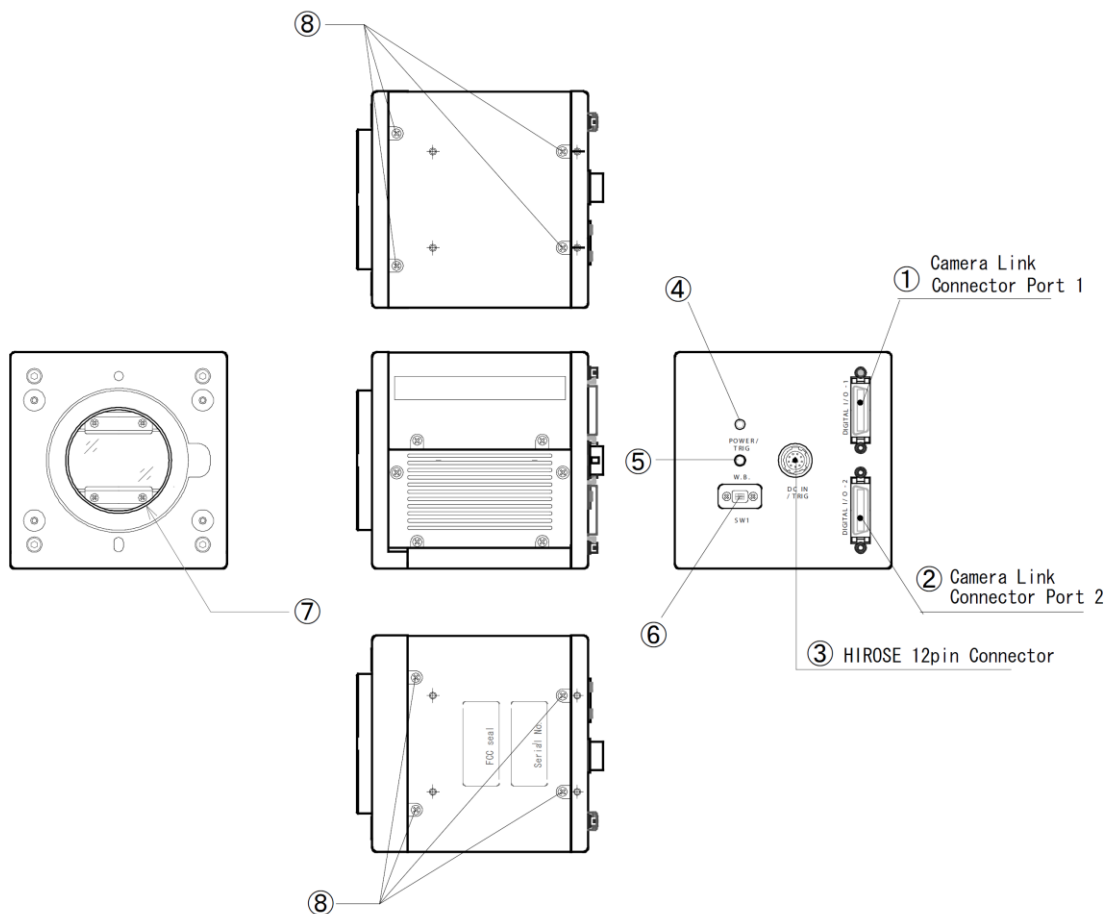

Fig. 1 Location of external features

- 1 Camera Link base connector (1) (*Note)
- 2 Camera Link medium connector (2) (*Note)
- 3 12-pin Hirose connector for DC +12, External trigger and RS-232C
- 4 LED indicator
 - Orange, steady: Initializing or one-push operation
 - Green, steady: Operating, but not receiving external trigger
 - Green, flashing: Operating and receiving external trigger
- 5 One-push auto white balance button
- 6 SW-1
- 7 Nikon F-Mount lens adapter
- 8 Mounting holes 8 x M3, depth 5mm

***Note:** When a Camera Link cable is connected to the camera, please do not excessively tighten screws by using driver. The Camera Link receptacle on the camera might be damaged. For security, the strength to tighten screws is less than 0.291 Newton Meter (Nm). Tightening by hand is sufficient in order to achieve this.

5. Connectors

5.1. 12-Pin Connector (Hirose)

Type: HR10A-10R-12PB-01 Hirose (Male)

Use the part number HR10A-10P-12S for the cable side

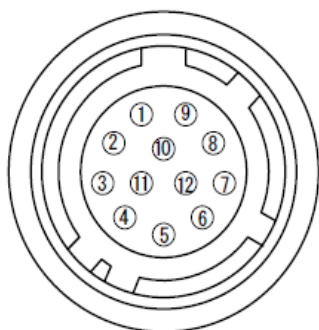

Pin No.	Signal	Remarks
1	GND	
2	+12V DC in	
3	GND	
4	Reserved	Do not connect
5	GND	
6	RxD in	RS-232C
7	TxD out	RS-232C
8	GND	
9	XEEN out	
10	Trigger in	TI=1, or set TI=0 for input via CL
11	+12V DC in	Option
12	GND	

Fig. 2 12-pin Hirose connector

5.2. Digital Output / Interface Connectors for Camera Link

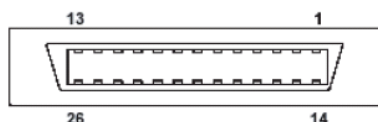

Type: 26P MRD Connector 3M 10226-1A10JL

Fig. 3 Camera Link connector

This camera can be used with all Camera Link products that comply with the AIA Camera Link standard. Cables, transmission systems and frame grabbers/acquisition boards that do not comply with the Camera Link standard may work with this camera, but JAI Camera Solutions cannot be held responsible for loss in performance or damage of equipment, including the camera.

Connector 1 (24Bit, 30 Bit)

Pin No	In/Out	Name	Note
1,14		Shield	GND
2(-),15(+)	O	TxOUT0	Data out
3(-),16(+)	O	TxOUT1	
4(-),17(+)	O	TxOUT2	
5(-),18(+)	O	TxCk	Clock for CL
6(-),19(+)	O	TxOUT3	Data out
7(+),20(-)	I	SerTC (RxD)	LVDS Serial Control
8(-),21(+)	O	SerTFG (TxD)	
9(-),22(+)	I	CC1 (Trigger)	Trigger
10(+),23(-)	I	CC2(Reserved)	
11,24		N.C	
12,25		N.C	
13,26		Shield	GND

Connector 2 (Used only for 3 x 10 Bit output)

Pin No	In/Out	Name	Note
1,14		Shield	GND
2(-),15(+)	0	TxOUT0	Data out
3(-),16(+)	0	TxOUT1	
4(-),17(+)	0	TxOUT2	
5(-),18(+)	0	TxCk	Clock for CL
6(-),19(+)	0	TxOUT3	Data out
7(+),20(-)		N.C	
8(-),21(+)		N.C	
9(-),22(+)		N.C	
10(+),23(-)		N.C	
11,24		N.C	
12,25		N.C	
13,26		Shield	GND

The CV-L108CL follows the Camera Link standard in all respects.

Please refer to the Camera Link version 1.1 specifications for detailed information on bit assignments of 24-bit RGB and 30-bit bit output.

5.3. Input and output circuits

5.3.1. Trigger input

The External Trigger signal can be applied either through the Camera Link connector or at pin 10 of the 12-pin Hirose connector. The command to change this setting is TI (Trigger Input). TI=0 for Camera Link connector (factory default) and TI=1 for 12-pin Hirose connector. The input via the 12-pin Hirose connector is AC coupled.

To allow long pulses, which may be required when using the Pulse Width Control (PWC) trigger mode, the input circuit is designed as a flip-flop circuit. The leading and trailing edges of the trigger pulse activate the circuit.

The trigger input polarity can be changed by the command TP. At the 12-pin Hirose connector the External Trigger input is $4V \pm 2V$ (TTL). It can be changed to 75 ohm termination by an internal switch setting (SW 801-2).

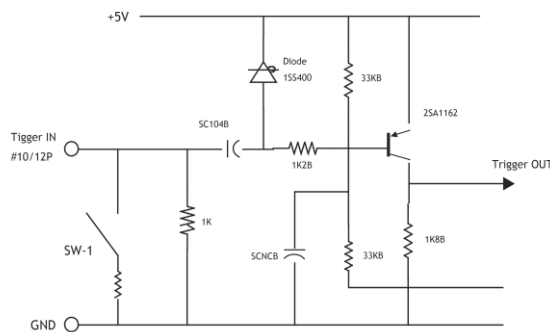

Fig. 4 Trigger input (12-pin Hirose)

5.3.2. EEN / XEEN output (Exposure ENable)

This output corresponds to the exposure (accumulation) time of the camera. It works together with all operation modes. It is, however, not active when the test pattern function is enabled. The EEN signal is available at the Camera Link connector and at the 12-pin Hirose connector at the same time.

At the Camera Link connector this signal has positive logic.

At pin 9 of the 12-pin Hirose connector the signal has negative logic, and is therefore named XEEN. The output circuit is a 75 ohm complementary emitter follower. The circuit is powered from the 5V supply, resulting in an output level of more than 4V. It is not terminated.

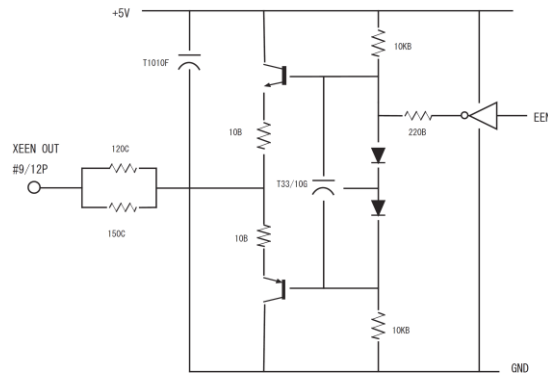

Fig. 5 XEEN Circuit (12-pin Hirose)

6. Functions and Operation

6.1. Basic functions

The CV-L108CL is built around three high-performance CCD line scan image sensors mounted on a prism block, as illustrated in Figure 6.

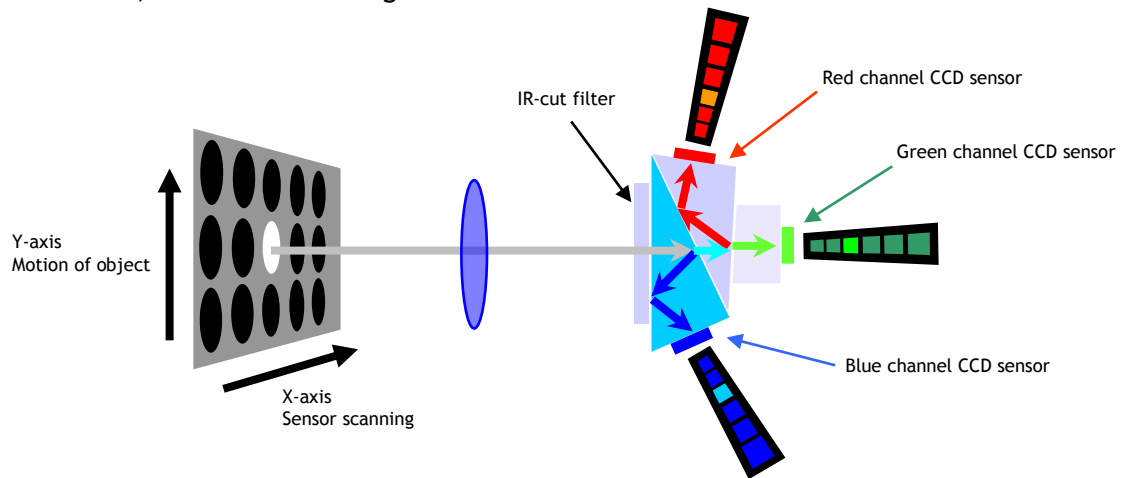

Fig. 6 Principle of a 3CCD line scan camera

During exposure, the incoming light is converted to electrons (electric charge) in the photodiodes (active pixels). The transfer gate controls the transfer of charge from photodiodes to the shift register. Activating the transfer gate terminates the exposure cycle, transfers the charge to the Horizontal Shift Register (2-phase buried channel CCD shift register) and starts a new exposure cycle. The line is subsequently read out in a single sequence starting with pixel 1. The exposure time is normally the same as the cycle time (in No-Shutter mode). By using the Exposure Control Gate (in Shutter-Select or Pulsed Width Control trigger modes) the exposure time can be individually set to be shorter than the cycle time (the inverse of line rate). This also allows a fixed exposure time, independent of the line rate. In the CV-L108CL the exposure time can be set individually for all three channels.

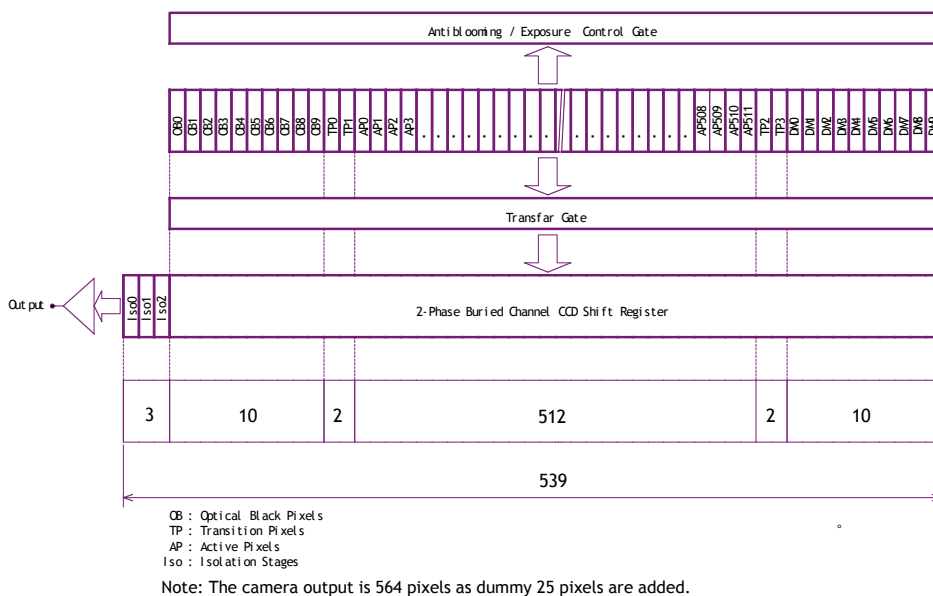
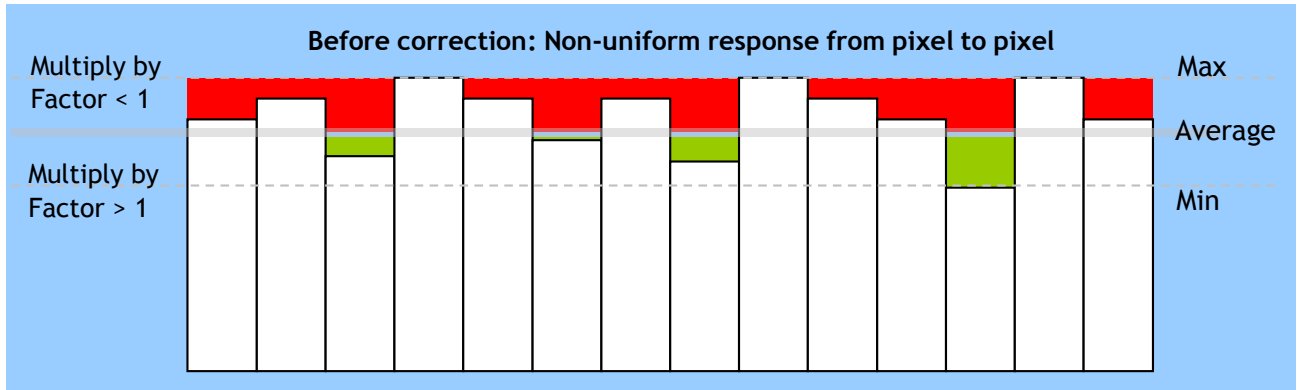

Fig.7 Sensor block diagram

6.2. Pixel Gain (flat-field) correction (PRNU correction)

Pixel Response Non-Uniformity is, as the name expresses, a non-uniformity of the response of each individual pixel. This means that for a fixed light level each pixel will have a slightly different output level (response).



To correct for PRNU, the camera's internal correction circuit captures one or several lines of data under non-saturated illuminated conditions (not more than 80% of maximum - recommend level is half of maximum), and the average across the line is calculated. Based on this average,

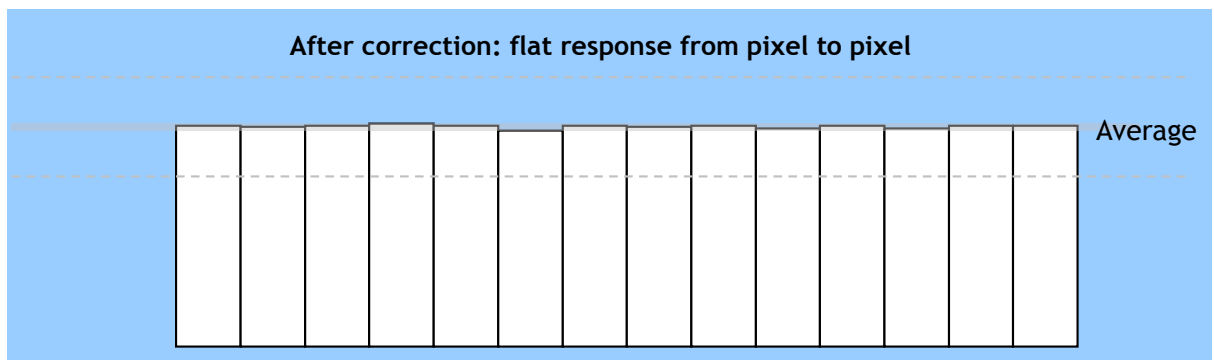

coefficients are then generated for each individual pixel. The coefficient has the function of multiplying the pixel output with factor greater or less than 1. These coefficients are stored in a non-volatile memory, and are therefore maintained after power down.

6.3. Pixel black level correction (DSNU / FPN correction)

Dark Signal Non-Uniformity or Fixed Pattern Noise is, as the name expresses, fixed pattern on the sensor output, which is *not* dependent on the incoming light.

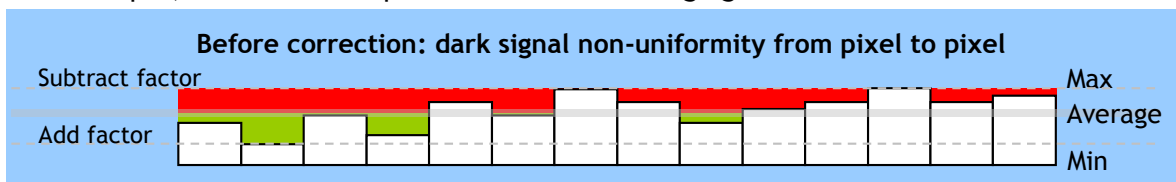

To correct for DSNU/FPN, the camera-internal correction circuit captures one or several lines of data under dark conditions (the lens *must* be covered by a lens cap), and the average across the line is calculated. Based on the average, coefficients are then generated for each individual pixel. The coefficient has the function of adding or subtracting a value to the pixel output. These coefficients are stored in a non-volatile memory, and are therefore maintained after power down.

As the dark signal is highly dependent on the exposure time, this correction must be performed under the operating conditions (exposure time and line rate) that will be used by the application.

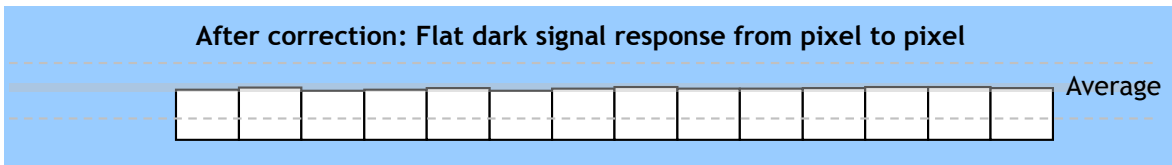

6.4. Shading correction

Shading is caused either by illumination with uneven distribution of light across the surface, or by vignetting towards the edges of a lens.

The shading correction incorporated in the camera will compensate for this effect by as much as 20% of the brightest signal.

Shading is not compensated for each individual pixel. The signal is averaged across groups of 8 pixels in relation to the whole line. The pixel response non-uniformity will be superimposed on the output also after shading correction has been performed. Therefore, it is recommended to perform a pixel gain (flat-field) correction after shading correction.

The Pixel Gain (flat-field) correction function is also used to compensate for shading, but it cannot handle a very wide dynamic range.

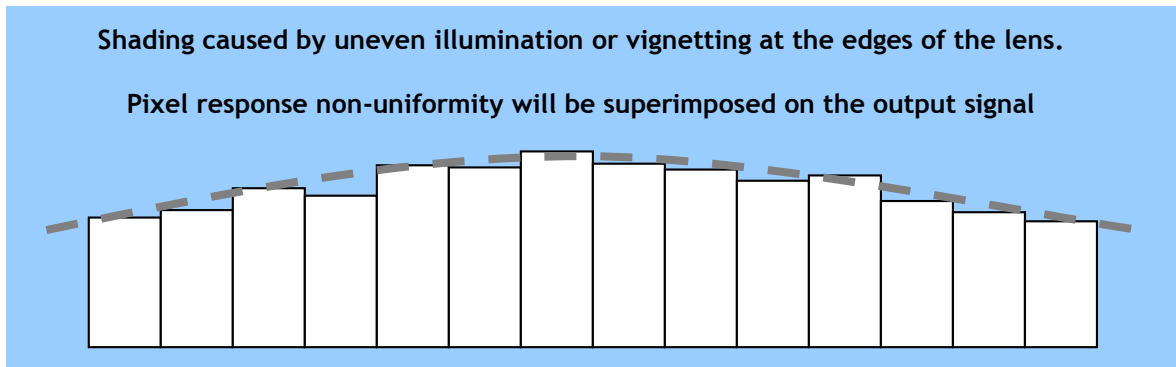

The shading correction can be configured to compensate each channel separately or can track the green channel.

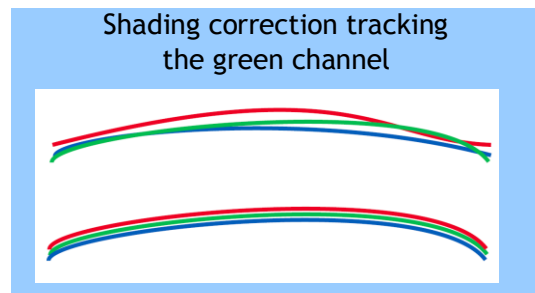
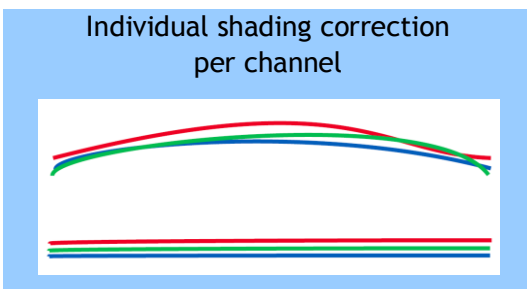

6.5. Binning

The binning function in this camera combines the charge collected in two adjacent pixels. This halves the effective resolution to 256 pixels, but doubles the sensitivity. The line rate is not affected by binning.

6.6. Operation modes

The CV-L108CL provides three basic modes of operation: No-shutter, Shutter-Select and Pulse Width Control (PWC). The Shutter-Select and PWC modes also allow the user to set the exposure time independently from the scan rate, by making use of the electronic shutter (the Exposure Control Gate of the CCD sensor).

The following sections describe these modes. The detailed timing of the video output, shown in figure 8, is common to all modes.

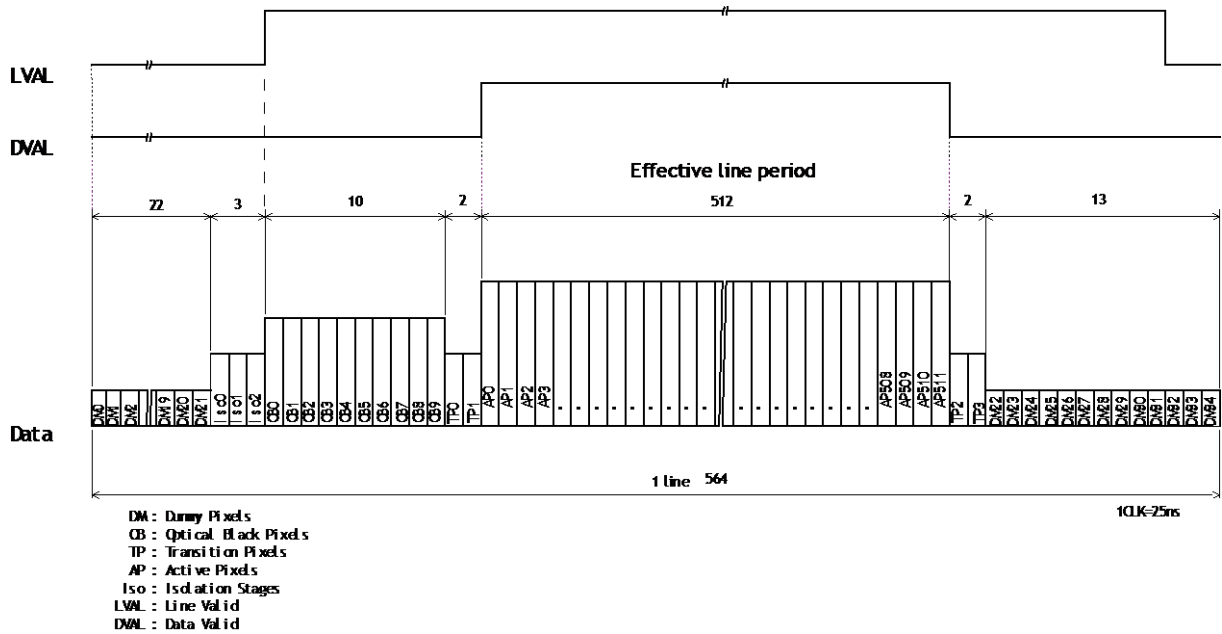

Fig.8 Video output timing

6.6.1. No-Shutter mode with internal line rate generator

In this mode the camera does not accept an external trigger signal, as the line rate is generated from an internal clock (user programmable, command LR). The exposure time is directly proportional to the line rate ($T_{exp} = 1/\text{line rate}$). This mode is used when there is no external trigger signal available, and the speed of the object is fixed or can be pre-determined.

The line rate can be varied from 1 line period (L) to 1024L in 1 clock (25ns) steps, 14.1 μ s to 14.438 ms. When using this mode, a special function called “One-push auto line rate” is available. This mode automatically maintains a constant output level by changing the line rate. See chapter 7 (configuring the camera) for further details on this function. The line rate is automatically adjusted in order maintain sensitivity without reducing the S/N ratio.

To use this mode:

Set function	Trigger mode, No-Shutter	TR=0
	Trigger origin, internal	TG=0
	Line rate	LR=564 to 577536 (14.10 μ s to 14.438 ms in 25ns increments)

Optional functions when using this mode:

One-push auto line rate	AR=0
Auto line rate reference	AL=0 to 1023
One-push white balance	WB

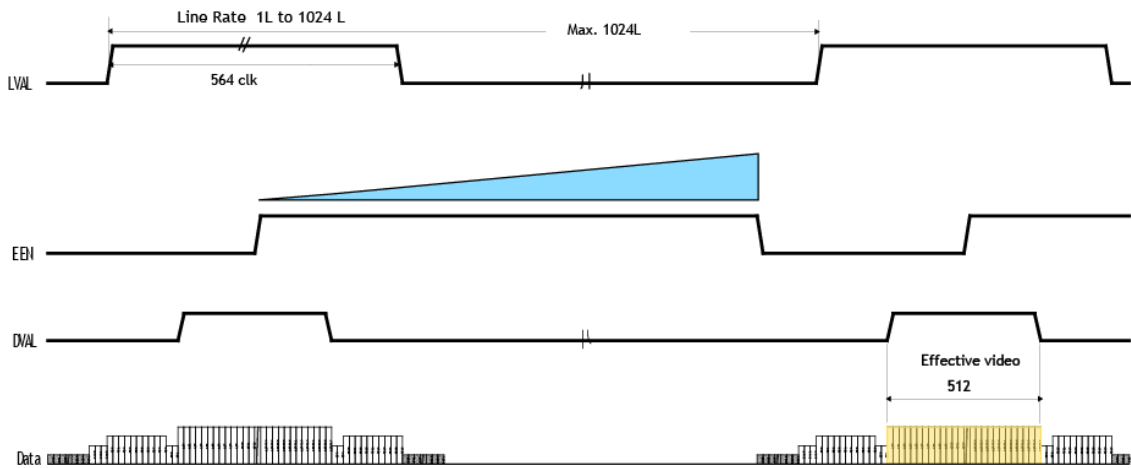

Fig. 9 No-Shutter mode with internal line rate generator

Important Note

- The “one-push auto line rate” function is not recommended for continuous web applications, as the speed of motion needs to be adjustable in order to maintain the aspect ratio of the image.
- Only gain based One-push white balance functions (WB) is available with this mode.

6.6.2. No-Shutter mode with external trigger

In this mode, the exposure time is directly proportional to the line rate. The line rate is generated externally by a trigger signal. This mode is used when an external trigger signal is available, e.g. from an encoder, and the scan rate can be controlled by this signal. The camera can accept an external trigger through the Camera Link connector or through the 12-pin Hirose connector.

To use this mode:

Set function	Trigger mode, No-Shutter	TR=0
	Trigger origin, external	TG=1
	Trigger input	TI=0 or 1

Important note:

- When the one-push white balance has been initiated and the rear panel LED shows orange, the camera must receive continuous external trigger pulses corresponding to the frequency and duty cycle used in the application.
- Minimum trigger interval is 14.2 μ s

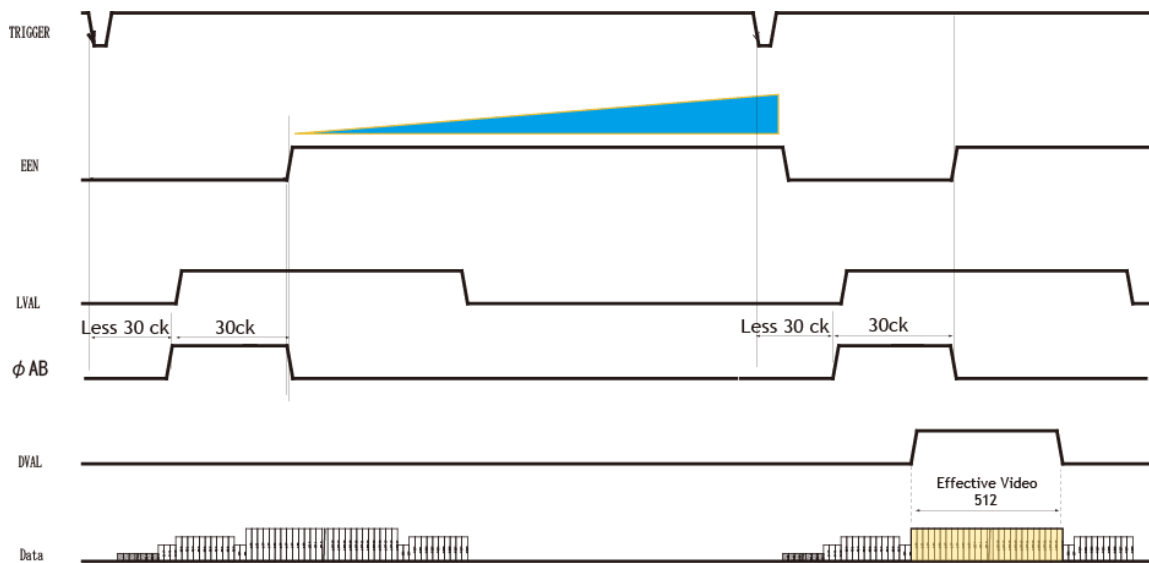

Fig. 10 No-Shutter mode with external trigger

6.6.3. Shutter-Select mode with internal line rate generator

This mode allows the user to have full control of the line rate and the exposure time individually, by programming separate timing generators. Subsequently the camera does not accept an external trigger signal in this mode.

To use this mode:

Set function	Trigger mode, Shutter-Select	TR=1
	Line rate	LR=14.2 μ s to 14.438 ms
	Trigger origin, internal	TG=0
	Individual R, G and B exposure	EI=0(individual) EI=1(tracking with G)
	Programmable exposure	PER/PEG/PEB=2 to 577536 (50 ns to 14.438 ms in 25ns steps)

Important note:

- If using individual exposure, the EEN signal represents the channel with the longest exposure time
- The maximum exposure time is that of setting line rate.

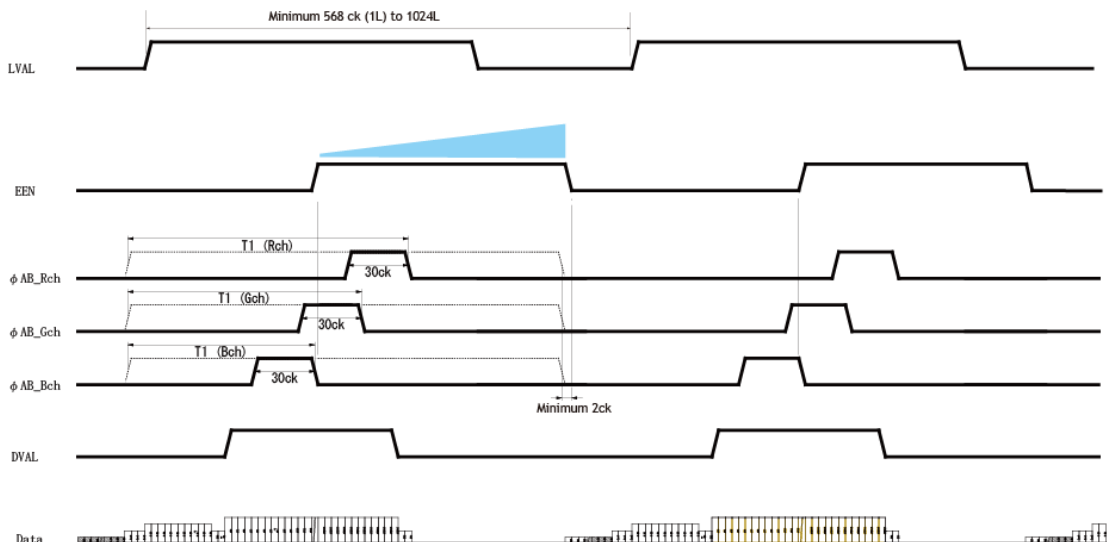

Fig. 11 Shutter-Select mode with internal line rate generator (and individual exposure)

6.6.4. Shutter-Select mode with external trigger

This mode allows the user to have full control of the exposure time, by programming a timing generator, while the line rate is controlled by an external trigger signal. The camera can accept an external trigger through the Camera Link connector or through the 12-pin Hirose connector.

To use this mode:

Set function	Trigger	TR=1
	Trigger origin, external	TG=1
	Individual R, G and B exposure	El=0(individual) El=1(tracking with G)
	Programmable exposure	PER/PEG/PEB=2 to 577536 (50 ns to 14.438 ms in 25ns steps)

Important note:

- If using individual exposure, the EEN signal represents the channel with the longest exposure time
- The minimum trigger interval is 14.2 μ s
- The maximum exposure time is the interval of trigger.

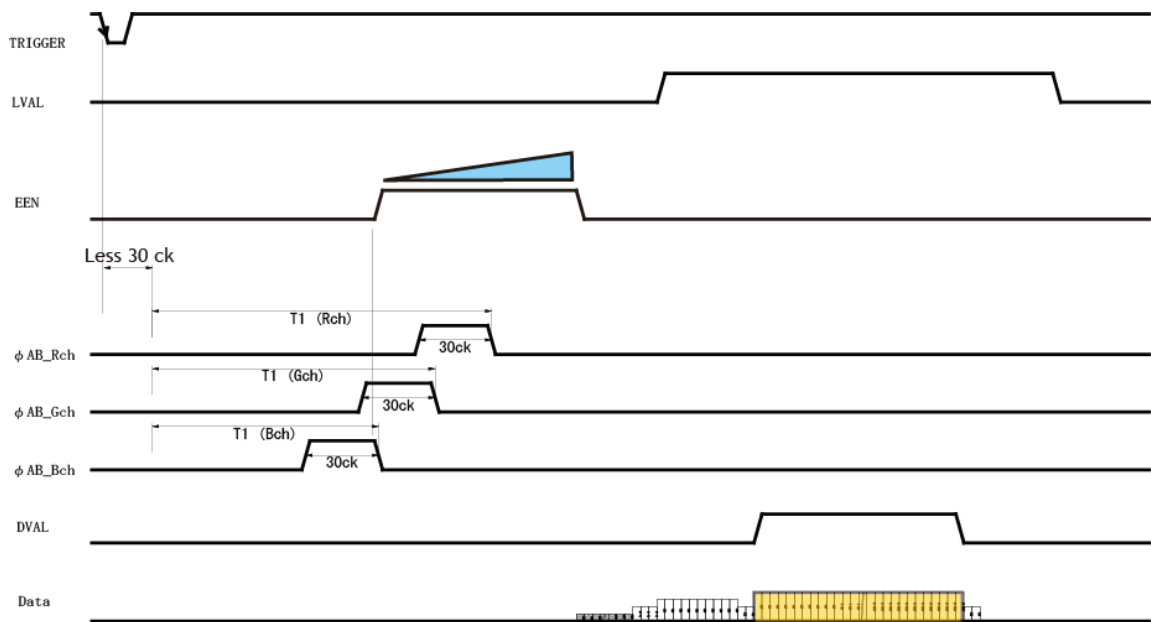

Note: Minimum period T1 is 30 clk.

Fig. 12 Shutter-Select mode with external trigger (and individual exposure)

6.6.5. Pulse Width Control (PWC) mode

In this mode, the user has full control of both the line rate and the exposure time of each line via the External Trigger input.

At the falling edge of the External Trigger signal, the exposure is initiated, and at the rising edge the exposure is terminated and read out. The camera can accept an external trigger through the Camera Link connector or through the 12-pin Hirose connector.

To use this mode:

Set function Trigger mode, PWC TR=2

Important Note:

- Possible pulse width:
 - TTL input (HIROSE 12-pin) 50 μ s to 1 sec.
 - CC1 input (Camera link) 2 μ s to 1sec.
- The minimum trigger interval is “exposure time + 14.2 μ s”.
- One-push white balance by gain setting only.
- When the one-push white balance has been initiated and the rear panel LED shows orange, the camera must receive continuous external trigger pulses corresponding to the frequency and

duty cycle used in the application.

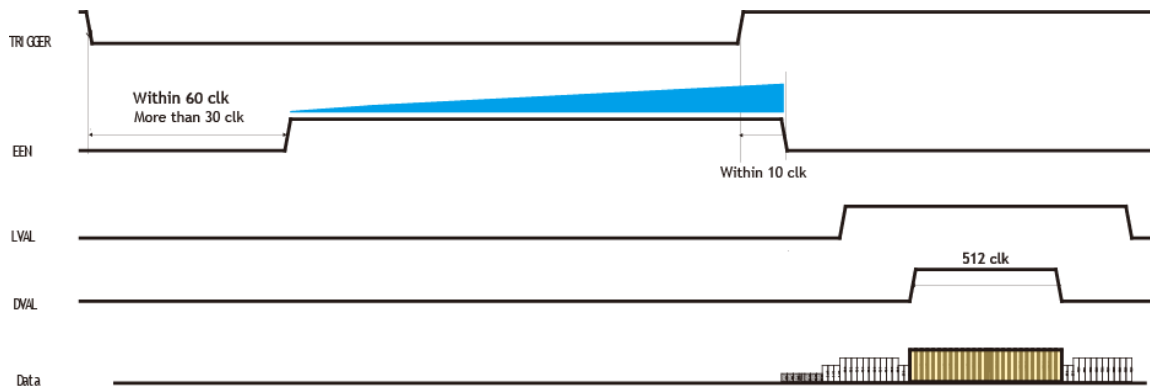

Fig. 13 Pulse Width Control mode

6.6.6. Auto Reset mode

In this mode, when the interval of the trigger pulse is more than 55ms, the CV-L108CL automatically returns to continuous operation with the line rate of 14.10 μ s. At this time, DVAL and Video OUTPUT are disabled in order to prohibit charge due to dark current to add up in the sensor in standby periods.

While the Auto Reset mode is "ON", if the trigger interval becomes less than 55ms, CV-L108CL operates in the original trigger mode selected.

Note: CV-L108CL functions properly according the selected operation mode while the Auto Reset mode is "ON". However, if the system uses LVAL, it is recommended to set the Auto Reset at "OFF" as LVAL is always output.

For this mode, CV-L108CL provides Auto Reset mode command "ARST".

In the default setting, "ARST" is set at "0" (OFF). In order to activate this mode, "ARST" should be set at "1".

The following is the concept of the Auto Reset Mode.

Auto Reset Mode

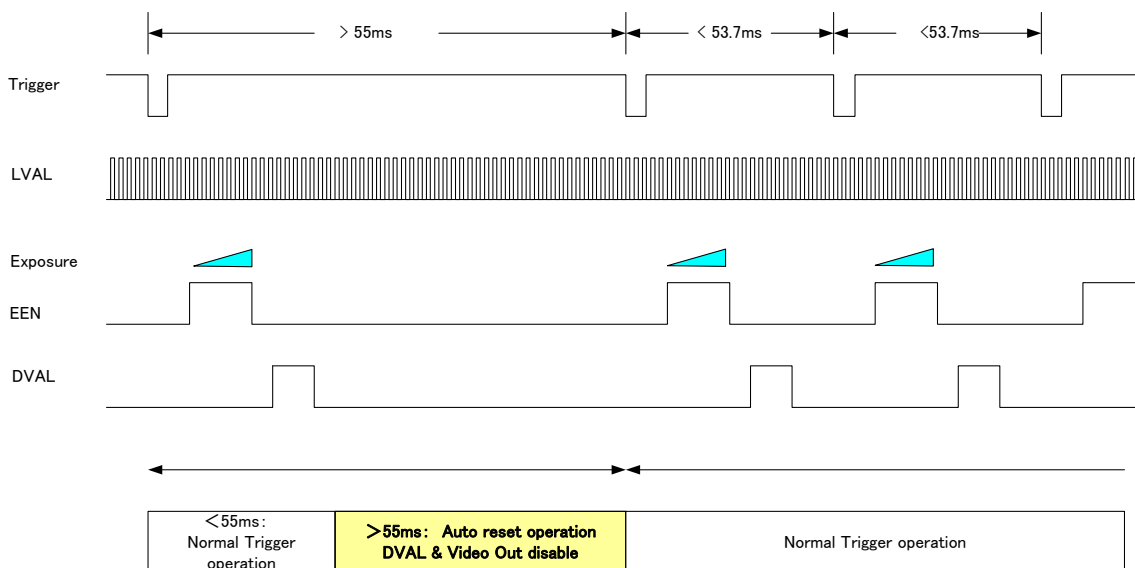

6.7. Scan rate and exposure time range

6.7.1. Minimum cycle time of external trigger

Mode	Minimum trigger cycle
No-Shutter	$C1 + 14.10\mu s$
Shutter-Select	$C1 + 14.10\mu s$
PWC	Exposure + $C2$

$C1 = 0.1 \mu s$; $C2 = 14.2 \mu s$

6.7.2. Minimum trigger pulse width.

Mode	Via Camera Link	Via Hirose 12P
No-Shutter	500ns	5 μs
Shutter-Select	500ns	5 μs
PWC	2 μs	50 μs

6.8. Relationship between Trigger and LVAL

Mode	Trigger	Trigger and LVAL mode Relations
No-Shutter	Internal	Synchronous
	External	
Shutter-Select	Internal	Synchronous
	External	Asynchronous
PWC	External	Asynchronous

6.9. Compatibility of trigger modes and functions

Mode	Functions								
	Trigger	Binning	Pixel gain & black correction	Shading correction	One-Push WB		Gain & black level ctr.	Program line rate	Program exposure time
					Gain	Shutter			
No-Shutter	Internal	Yes	Yes	Yes	Yes	No	Yes	Yes(*1)	No
	External	Yes	Yes	Yes	Yes	No	Yes	Yes(*1)	No
Shutter-Select	Internal	Yes	Yes	Yes	Yes	Yes	Yes	Yes(*2)	Yes

	External	Yes	Yes	Yes	Yes	Yes	Yes	Yes(*2)	Yes
PWC	External	Yes	Yes	Yes	Yes	No	Yes	No	No

*1: Exposure time is trigger interval.

*2: Exposure time can be set but the maximum exposure time is trigger interval.

6.10. Rear panel indicator

There is a multi-color LED on the rear panel of the camera. It has the following functions:

Green (Steady)

Operating, but not receiving external trigger input

Green (Flashing)

Operating and receiving external trigger input.

Note that the flashing frequency does not correspond to the frequency of the trigger signal.

Orange

Initializing or busy calculating White Balance, Flat-Field or Shading correction parameters.

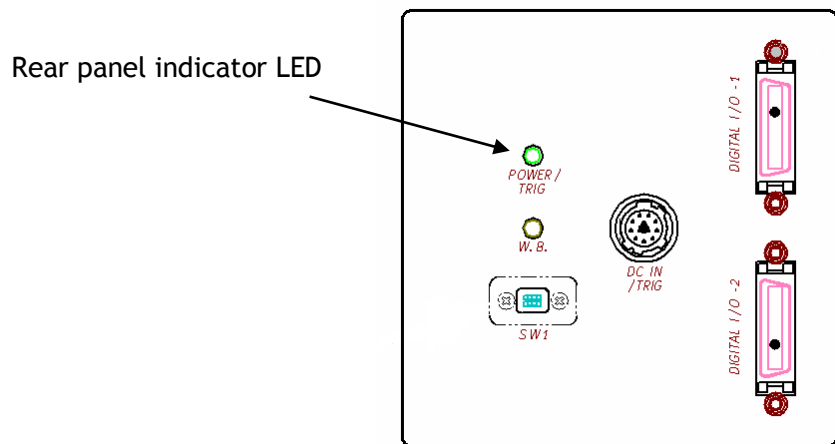

7. Configuring the camera

All the modes and functions of this camera are controlled by serial communication, via the Camera Link connector or via RS-232C on the Hirose 12-pin connector.

Chapter 7.1 shows the complete list of ASCII commands. Chapter 7.2 describes the commands in detail, in alphabetical order (sorted by command the acronym)

7.1. CV-L108CL Command list

	Command Name	Format	Parameter	Remarks
A - General settings and useful commands.				
EB	Echo Back	EB=[Param.]<CR><LF> EB?<CR><LF>	0=Echo off, 1=Echo on	Returns character sent to the camera. Off at power up
ST	Camera Status Request	ST?<CR><LF>		Display current settings of all functions
HP	Online Help Request	HP?<CR><LF>		Get a list of available commands
VN	Firmware Program Version Request	VN?<CR><LF>		3 digits Example: 100 = Version 1.00
PV	FPGA Program Version Request	PV?<CR><LF>		3 digits Example: 100 = Version 1.00
ID	Camera ID Request	ID?<CR><LF>		Returns the camera's ID (?). Factory setting.
MD	Model Name Request	MD?<CR><LF>		Returns the camera's model name. Factory setting.
UD	User ID	UD=[Param.]<CR><LF> UD?<CR><LF>		User definable field. Up to 16 characters.
B - Line Rate, Exposure				
LR	Line Rate	LR=[Param.]<CR><LF> LR?<CR><LF>	564 to 577536, in 25ns increments	Only valid for TG=0
TG	Trigger origin	TG=[Param.]<CR><LF> TG?<CR><LF>	0=Internal clock generator 1=External signal	Only valid for TR=0, or 1
AR	One-push auto line rate set	AR=[Param.]<CR><LF> AR?<CR><LF>	0=Activate one-push auto line rate set	Only valid for TR=0 and TG=0
AL	Auto line rate reference level	AL=[Param.]<CR><LF> AL?<CR><LF>	0 to 1023	Only valid for TG=0
EI	RB Exposure interlocked with G	EI=[Param.]<CR><LF> EI?<CR><LF>	0=Off (independent) 1=On (interlocked)	Only valid for TR=1
PER	Programmable Exposure - Red	PER=[Param.]<CR><LF> > PER?<CR><LF>	2 to 577536, in 25ns increments	Only valid for TR=1

PEG	Programmable Exposure - Green	PEG=[Param.]<CR><LF> > PEG?<CR><LF>	2 to 577536, in 25ns increments	Only valid for TR=1
PEB	Programmable Exposure - Blue	PEB=[Param.]<CR><LF> > PEB?<CR><LF>	2 to 577536, in 25ns increments	Only valid for TR=1
AH	One-push AWB shutter	AH=[Param.]<CR><LF>	0=Activate one-push AWB shutter	Only valid for TR=1
AHRS	Get status after one-push AWB shutter	AHRS?<CR><LF>	<One of following values will be replied from the camera> 0=Succeeded. 1=AWB has not been finished yet. 2=Error1. Green image was too bright. 3=Error2. Green image was too dark. 4=Error3. Timeout-error occurred.	
C - Trigger mode				
TR	Trigger Mode	TR=[Param.]<CR><LF> TR?<CR><LF>	0=No-Shutter mode 1=Shutter-Select mode 2=Pulse Width Control mode	
TI	Trigger Input	TI=[Param.]<CR><LF> TI?<CR><LF>	0=Camera-Link 1=Hirose12pin	
TP	Trigger Polarity	TP=[Param.]<CR><LF> TP?<CR><LF>	0=Active-Low 1=Active-High	
D - Image format				
BI	Binning	BI=[Param.]<CR><LF> BI?<CR><LF>	0=Binning Off, 1=Binning On	
BA	Bit allocation	BA=[Param.]<CR><LF> BA?<CR><LF>	0=24bit, 1=30bit	
TS	Test Pattern	TS=[Param.]<CR><LF> TS?<CR><LF>	0=Off 1=Color Bar 2=Gray Pattern 1 3=Gray Pattern 2 4=White	Off at power up
E - Gain, white balance and signal settings				
GA	Gain Level - Master	GA=[Param.]<CR><LF> GA?<CR><LF>	-132 to 429	0=0dB
GAR	Gain Level - Red	GAR=[Param.]<CR><LF> GAR?<CR><LF>	-231 to 231	
GAB	Gain Level - Blue	GAB=[Param.]<CR><LF> GAB?<CR><LF>	-231 to 231	
BL	Black Level - Master	BL=[Param.]<CR><LF> BL?<CR><LF>	0 to 127	
BLR	Black Level - Red	BLR=[Param.]<CR><LF> BLR?<CR><LF>	-64 to 63	

BLB	Black Level - Blue	BLB=[Param.]<CR><LF> BLB?<CR><LF>	-64 to 63	
WB	White Balance	WB=[Param.]<CR><LF> WB?<CR><LF>	0=Manual/One push AWB 1=4000K 2=4600K 3=5600K	
AW	Activate One-push AWB	AW=[Param.]<CR><LF>	0=Activate one-push AWB	
AWRS	Inquire the status after one-push AWB	AWRS?<CR><LF>	<Camera replies > 0=AWB has not been finished yet. 1=Succeeded. 2=Error1. Green image was too bright. 3=Error2. Green image was too dark. 4=Error3. Timeout-error occurred.	
KN	Knee On/Off	KN=[Param.]<CR><LF> KN?<CR><LF>	0=Off, 1=On	
KSR	Knee Slope - Red	KSR=[Param.]<CR><LF> KSR?<CR><LF>	0 to 16383	
KSG	Knee Slope - Green	KSG=[Param.]<CR><LF> KSG?<CR><LF>	0 to 16383	
KSB	Knee Slope - Blue	KSB=[Param.]<CR><LF> KSB?<CR><LF>	0 to 16383	
KPR	Knee Point - Red	KPR=[Param.]<CR><LF> KPR?<CR><LF>	0 to 1023	
KPG	Knee Point - Green	KPG=[Param.]<CR><LF> KPG?<CR><LF>	0 to 1023	
KPB	Knee Point - Blue	KPB=[Param.]<CR><LF> KPB?<CR><LF>	0 to 1023	
GAR2	Fine gain - red	GAR2=[Param.]<CR><LF> GAR2?	31768 to 33768	32768=1 31768/32768 (0.97) to 33768/32768 (1.03)
GAB2	Fine gain - Blue	GAB2=[Param.]<CR><LF> GAB2?	31768 to 33768	32768=1 31768/32768 (0.97) to 33768/32768 (1.03)
NOSR	Noise reduction	NOSR=[Param.]<CR><LF> NOSR?	0 = OFF, 1= ON	
F - Shading correction, pixel gain and pixel black correction				
SDC	Select shading correction mode	SDC=[Param.]<CR><LF> SDC?<CR><LF>	0=Off (Bypass) 1=Factory area 2=User area	
SDR	Run shading correction, store to user area	SDR=[Param.]<CR><LF>	0=Run flat shading correction, store to user area 1=Run color shading correction, store to user area	Store in user setting.
SDS	Inquire the status after	SDS?<CR><LF>	0=Shading correction not yet completed.	

	shading correction		1=Succeeded. 2=Error1 - Timeout error occurred.	
PGC	Select pixel gain correction mode	PGC=[Param.]<CR><LF> PGC?<CR><LF>	0=Off (Bypass) 1=Factory area 2=User area	Only valid for SHC=0.
PGR	Run pixel gain correction, store to user area	PGR=[Param.]<CR><LF> PGR?<CR><LF>	0=Run pixel gain correction, store to user area	Store in user setting.
PGS	Inquire the status after pixel gain correction	PGS?<CR><LF>	0=Pixel gain correction not yet completed. 1=Succeeded. 2=Error1 - Timeout error occurred.	
PBC	Select pixel black correction mode	PBC=[Param.]<CR><LF> PBC?<CR><LF>	0=Off (Bypass) 1=Factory area 2=User area	
PBR	Run pixel black correction, store to user area	PBR=[Param.]<CR><LF> PBR?<CR><LF>	0=Run pixel black correction, store to user area	Store in user setting.
PBS	Inquire the status after pixel black correction	PBS?<CR><LF>	0=Pixel black correction has not been finished yet. 1=Succeeded. 2=Error1 - Timeout error occurred.	
ARST	Auto Reset mode	ARST=[Param.]<CR><LF> ARST?<CR><LF>	0=OFF 1=ON	
G - Saving and loading data in EEPROM				
LD	Load Settings (from Camera EEPROM)	LD=[Param.]<CR><LF>	0=Factory area 1=User area1 2=User area2	Latest used DATA AREA will become default at next power up.
SA	Save Settings (to Camera EEPROM)	SA=[Param.]<CR><LF>	1=User area1 2=User area2 Note the parameter 0 is not allowed.	
EA	EEPROM Current Area No. Request.	EA?<CR><LF>	0=Factory area 1=User area1 2=User area2	The camera returns latest used DATA AREA.

Note: To avoid malfunction, do not attempt writing commands not shown in the above list.

8. Functions listed alphabetically by command acronyms

8.1 Command **AHRS** - Request status after One-Push AWB

This command returns the status of the One-Push AWB function, with the following parameters:

0=AWB not completed yet
 1=Succeeded
 2=Error1: Green image too bright
 3=Error2: Green image too dark
 4=Error3: Timeout occurred

8.2 Command **AL** - Automatic Line Rate Reference Level

Settings: 0 to 1023
 Applicable modes: No-Shutter with Internal line rate generator
 Associated functions: Command AR

8.3 Command **AR** - Automatic Line Rate setting

This function will calculate and set the line rate of the camera based on the Automatic Line Rate Reference Level (as set in command AL) and the scene illumination. Please note that the aspect ratio of the scanned object will change as the line rate is changed.

Settings: 0 (activate automatic process)
 Applicable modes: No-Shutter with internal line rate generator
 Associated functions: Command AL

Important note

- The data can be stored in the camera memory for next start up.

8.4 Command **ARST** - Auto Reset Mode

This function enables/disables the Auto Reset mode, which prevents offset rising in special case where line triggers are not received for long period of time.

Settings 0 (off) and 1 (on). Factory default is 0(off).

8.5 Command **AW** - Activate One-push Auto White Balance (AWB) - Gain

By sending this command via the serial communication, the *gain based* One-Push AWB function is activated. This function can also be initiated by pressing the rear panel button. The white balance function takes approximately 3 seconds to complete. During this time the rear panel LED will show orange.

This function operates in two steps. First the Red-to-Green channel difference and the Blue-to-Green channel difference is calculated separately. Then the gain of the Blue and Red channel is automatically adjusted, to obtain the same output level on all three channels.

Settings: 0 = activate automatic process
 Applicable modes: All
 Associated functions: Command WB
 Rear panel One-push WB button.

Important Note:

- When color temperature of used illumination exceeds the range of adjustment, proper white balance may not be obtained.
- The data can be stored in camera memory for use at next start up.
- This function can work on external trigger mode.
- Please refer Chapter 7.5 operation mode for the details.
- The S/N ratio of the output will change as a result of this function.

8.6 Command AH - Activate One-push Auto White Balance (AWB) - Shutter

By sending this command via the serial communication, the *shutter based* One-Push AWB function is activated. The white balance function takes approximately 3 seconds to complete. During this time the rear panel LED will show orange.

This function operates in two steps. First the Red-to-Green channel difference and the Blue-to-Green channel difference is calculated separately. Then the exposure time of the Blue and Red Channel is automatically adjusted, to obtain the same output level on all three channels.

Settings: 0 = activate automatic process
 Applicable modes: Shutter-Select mode only
 Associated functions: Command WB

Important Note:

- When color temperature of used illumination exceeds the range of adjustment, proper white balance may not be obtained.
- The data can be stored in camera memory for use at next start up.
- This function can work on external trigger mode.
- Please refer Chapter 7.5 operation mode for the details.
- The S/N ratio of the output will remain constant for all channels

8.7 Command BA - Bit Allocation

This function lets the user select whether the video data is presented as 3 x 8 (24)-bit or 3 x 10 (30)-bit on the Camera Link output. The internal processing in the camera is based on a 12 bit A/D signal. The 24-bit and 30-bit function removes the least significant bits from the 12 bit signal.

Settings: 0=24-bit, 1=30-bit
 Applicable modes: All

8.8 Command BI - Binning (Horizontal only)

This function reduces the number of pixels to 256 without affecting the line rate. Two adjacent pixels are combined at the output stage and read out as one pixel. Sensitivity is doubled as a result of binning.

Settings: 1=binning on, 0=binning off
 Applicable modes: All

Important Note:

- Setting data is stored in camera memory for use at next start up
- This function is available for all modes.

8.9 Command BL - Master Black Level

This command is a global black level adjustment for all channels. The adjustable range for master black is 0LSB to 64 (16) LSB. The number in parenthesis is valid for 24-bit output.

Settings: 0 to 127
 Associated functions: Command BLR - black level for the red channel.
 Command BLB - black level for the blue channel.

8.10 Commands BLR and BLB - Black level red and black level blue

In conjunction with Command BL, these commands allow individual setting of the black level in all channels.

Settings: -64 to 63
 Associated functions: Command BL

8.11 Command EI - Interlocked R, G and B exposure

When this function enabled (interlocked), exposure time for all three is selected by setting the Green channel and the Red and Blue channels will track.

To obtain white balance, adjust Red and Blue channels, PER and PEB. It is thereafter possible to adjust overall exposure time by using the command PEG. The Red and Blue channels will track the Green channel proportionally, thus maintaining white balance settings.

Settings: 0= independent R, G and B settings
 1= R and G channel tracking with G
 Associated functions: Commands PER, PEG, PEB - Programmable Exposure
 Applicable modes: Shutter-select mode only

8.12 Command GA - Master Gain Level

This function is a global gain adjustment for all channels.

Settings: -123 to 429
 Associated functions: Commands GAR and GAB - Gain level red and gain level blue.

8.13 Commands GAR and GAB - Gain level red and gain level blue.

In conjunction with the Command GA, this function allows the individual setting of gain for all channels. It is important to note that increasing the gain will lead to an increased noise level and reduced S/N-Ratio.

Settings: -231 to 231
 Associated function: Command GA - Master gain level
 Applicable modes: All modes

8.14 Commands GAR2 and GAB2 - Fine gain (R ch and B ch)

Fine gain can be digitally controlled.

Settings: 31768 to 33768
 x0.969 (31768/32768) to x1.03(33768/32768) (R ch and B ch)

8.15 Command NK - Knee function enable/disable

This command turns the knee function on or off.

The sensor output is digitized to 4095LSB of dynamic range. When input (CCD output) and output (Camera link data) relations is set at linear, the output is clipped at 1023 LSB and

the details above 1023 are not visible. This function changes the gain signal from CCD over 100% video output level and compress signal up to 4095 LSB. The knee point is the upper limit of linear relations between CCD output and input to Camera Link. The knee slope decides how much of the signal above 100% video output is compressed. Knee point and Knee slope can be set on R, G and B respectively.

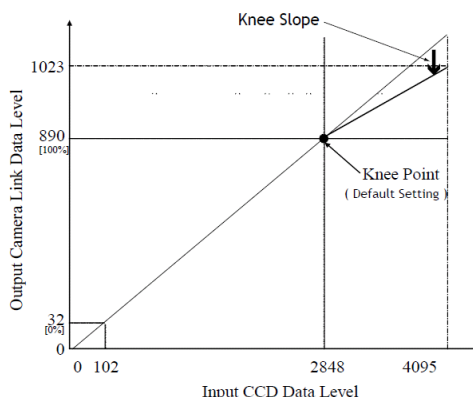

Fig. 14 Principle of Knee function

Settings: 0=off, 1=on
 Associated functions: Commands KSR, KSG and KSB - Knee slope for R, G and B
 Commands KPR, KPG and KPB - Knee point for R, G and B

8.16 Commands KSR, KSG and KSB - Knee slope for R, G and B

See command KN for description of this function

Settings: -8192 to 8191
 Associated functions: Command KN, Commands KPR, KPG and KPB

8.17 Commands KPR, KPG and KPB - Knee point for R, G and B

See command KN for description of this function

Settings: 0 to 1023
 Associated functions: Command KN, Commands KSR, KSG and KSB

8.18 Command LR - Line Rate (Scan Rate)

This function is used only when there is no external trigger pulse (e.g. from an encoder) available. It allows the user to program the line rate, in order to match the speed of the object being scanned. In the No-Shutter mode, the exposure time is directly proportional to the line rate ($T_{exp} = 1/\text{line rate}$)

Settings: 564 to 577536, 14.1µs to 14.438ms in 25ns increments
 Associated functions: Trigger origin, TG=0
 Applicable modes: No-Shutter with internal line rate generator (TR=0)
 Shutter-Select with internal line rate generator (TR=1)

Important note

- The data can be stored in the camera memory for next start up.

8.19 Command NOSR - Noise reduction

This function deletes the noise component of less than 16LSB composed in the signal. This circuit used in the CV-L107CL minimizes the deterioration of the spatial frequency. The improvement depends on the object and it will be approx. 3dB.

Settings: 0=ON, 1=OFF

8.20 Command PBC - Enable pixel black (FPN) correction

This command enables (or disables) the “pixel black level” correction function, which compensates for Dark Signal Non Uniformity / Fixed Pattern Noise (DSNU / FPN) for individual pixels.

Settings: 0 = Off (Default)
1 = Factory setting
2 = user area

Associated functions: Command PBR

Applicable modes: All

8.21 Command PBR - Run pixel black correction and store to user area

This command initiates the “pixel black level” correction function, and stores the settings in the user area. When this function is activated, lens must be capped.

Settings: 0 = Run this function
Associated functions: Command PBC must be set to 2

Important note:

- This function requires that no light reaches the image sensors. The lens must therefore be covered by a lens cap, or put the F-mount protective cover on the camera, when executing this function.
- As the black level is influenced by the exposure time (especially for long exposure time, at slow scan rates) it is recommended to perform the pixel black correction at the exposure time and line rate at which the camera will be operated.

8.22 Command PER - Programmable exposure - Red

This command allows individual setting of the exposure time of the Red channel. It is only valid for the Shutter-Select mode (see chapter 6.2)

Settings: 2 to 577536, 50 ns to 14.438 ms in 25ns steps
Associated functions: EI (R and G exposure interlocked with G)

The actual Exposure time (ns) is calculated as follows:

$$T_{\text{exp}} = 25\text{ns} \times (\text{Repetition period} ([\text{Parameter}]) - (T1 ([\text{Parameter}]) + 21 [\text{Parameter}]))$$

8.23 Command PEG - Programmable exposure - Green

This command allows individual setting of the exposure time of the Green channel. It is only valid for the Shutter-Select mode (see chapter 6.2)

Settings: 2 to 577536, 50 ns to 14.438 ms in 25ns steps
Associated functions: EI (R and G exposure interlocked with G)

8.24 Command PEB - Programmable exposure - Blue

This command allows individual setting of the exposure time of the Blue channel. It is only valid for the Shutter-Select mode (see chapter 6.2)

Settings: 2 to 577536, 50 ns to 14.438 ms in 25ns steps
 Associated functions: EI (R and G exposure interlocked with G)

8.25 Command PGC - Enable Flat-field correction (Pixel gain)

This command enables (or disables) the “pixel gain” (flat-field) correction function, which compensates for Pixel Response Non Uniformity (PRNU) for individual pixels.

Settings: 0=Off (Default)
 1=Factory Setting
 2=User area
 Associated functions: Command PGR
 Applicable modes: All

8.26 Command PGR - Run Flat-field correction and store in user area

This command initiates the flat-field correction function, and stores the settings in the user area.

Settings: 0= activate automatic process
 Associated functions: Command PGC must be set to 2

Important note:

- The image sensors must not be saturated when executing this function.
- When executing this function, the exposure time and line rate should be the same as when the camera is operated in the application.

Operating procedure for individual R, G and B channel shadings correction:

1. Before making adjustment, it is required approximately 30 minutes warming up.
2. Make sure the output signal is not saturated (80% of full output is recommended)
3. Set command PGC=2 .
4. Set command PGR to 0 to initiate shading correction.
5. If desired, set command SDR to 0 or 1 to activate shading correction to correct the shading caused by lens or lighting. When the shading correction is performed, the flat-field correction must be activated before the shading correction is performed.

8.27 Command SDC - Select shading correction mode

This function enables (or disables) the shading correction.

Settings: 0 = off (Bypass) (Default)
 1 = Factory setting
 2 = User area
 Associated functions: Commands PGR, SDR and SDS

8.28 Command SDR - Run shading correction

This function initiates automatic shading correction, and stores the result to the user area. This function should be used together with the flat-field correction (commands PGC and PGR). There are two types of shading correction: Individual R, G and B channel correction and chromatic shading correction.

(A) Individual R, G and B channel correction (SDR=0)

Shading is calculated and individually compensated for R, G and B channels respectively. The calculation is based on the average value of 8 consecutive pixels. The maximum deviation that can be compensated is -20% of the highest signal level (brightness) of the line.

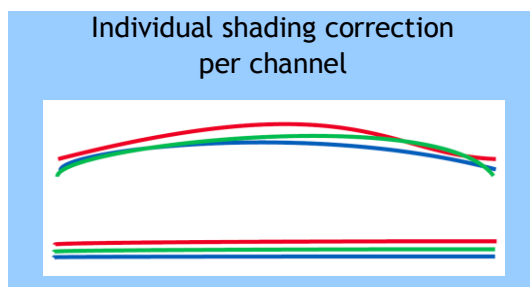

Important note:

- Depending on the optics and/or illumination used together with the camera, it may not be possible to fully compensate for shading.

Operating procedure for individual R, G and B channel shadings correction:

1. Before making adjustment, it is required approximately 30 minutes warming up.
2. Make sure the output signal is not saturated (80% of full output is recommended)
3. Set command PGC=2 and SDC=2.
4. Set command SDR to 0 to initiate shading correction.
5. If desired, set command PGR to 0 to activate flat-field (pixel gain) correction to correct for pixel response non-uniformity.
6. Again set SDR=0 after running the flat-field (pixel gain) correction

(B) Chromatic shading correction (SDR=1)

In this mode, shading correction of R and B signals is referenced to the G signal which is the reference. When the Green channel detects “undulating” or “parabolic” type shading, R and B channels are compensated to follow the same curve. The calculation is based on the average value of 8 consecutive pixels

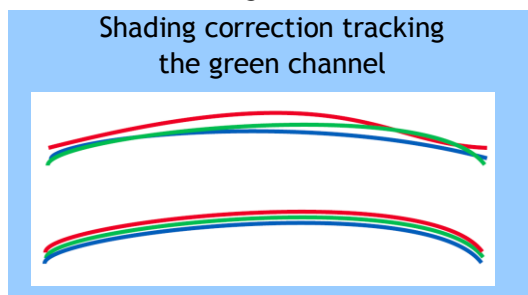

Important Note:

- For this function, no reference value is stored in the camera.

Operating procedure for individual R, G and B channel shadings correction:

1. Before making adjustment, it is required approximately 30 minutes warming up.
2. Make sure the output signal is not saturated (80% of full output is recommended)
3. Set command PGC=2 and SDC=2.
4. Set command SDR to 1 to initiate shading correction.
5. If desired, set command PGR to 0 to activate flat-field (pixel gain) correction to correct for pixel response non-uniformity.

6. Again set SDR=1 after running the flat-field (pixel gain) correction

8.29 Command SDS - Request status after executing shading correction command
 This command returns the status of the shading correction function, with the following parameters:
 0=Shading correction not completed yet
 1=Successful
 3=Error1 - Timeout occurred

8.30 Command TG - Trigger Origin
 Selects whether an external signal or an internal clock generator is used as a trigger source.

Settings: 0=Internal clock generator
 1=External signal

Associated commands: TI
 TP

8.31 Command TI - Trigger input
 Selects whether the External Trigger input signal is taken from the Camera Link connector, or from the 12-pin Hirose connector.

Settings: 0=Camera Link connector
 1=12-pin Hirose connector

Important Note

The 12-pin Hirose connector trigger input can be terminated for 75 ohm. This is selected by a rear panel DIP-switch (SW1).

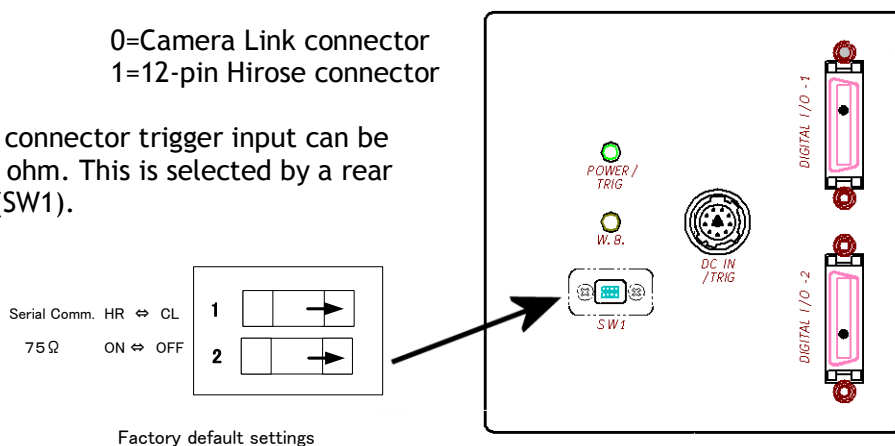

Fig.15 DIP switch

8.32 Command TP - Trigger polarity

Settings: 0=Active Low (factory default)
 1=Active High

8.33 Command TR - Trigger Mode
 Selects the trigger mode of the camera. Depending on the mode used, it allows the scan rate to either be programmed by an internal timing generator or by and external trigger pulse. See chapter 6 for details on the operation modes.

Settings: 0=No-Shutter mode
 1=Shutter-Select mode
 2=Pulse Width Control (PWC) mode

Associated functions: Command TG (trigger origin)
 Command TI (trigger input)
 Command TP (trigger polarity)

8.34 Command **TS** - Test pattern

This allows the camera to output a number of test patterns for set-up and troubleshooting.

- Settings:
- 0=off
 - 1=Color bar
 - 2=Gray wedge
 - 3=Gray bars
 - 4=White (890LSB)

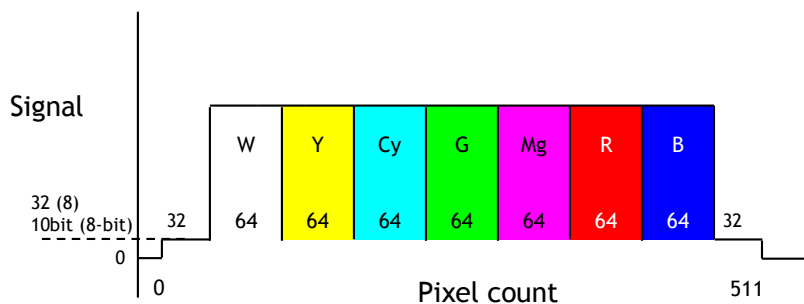

Fig. 16 Color bar test pattern

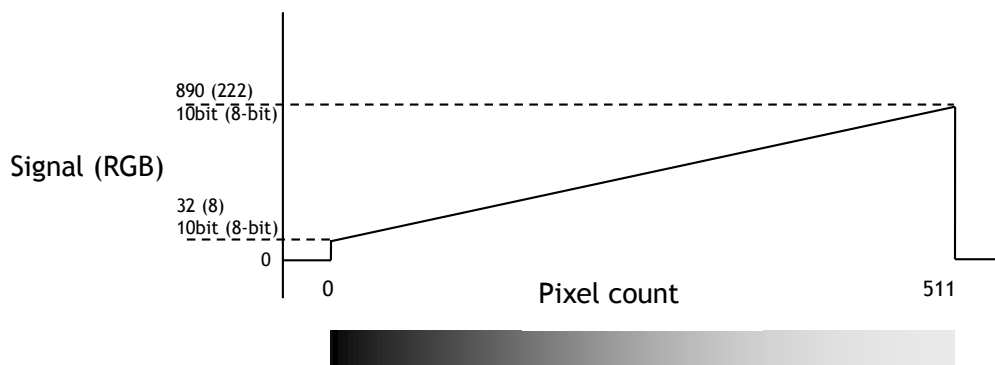

Fig. 17 Grey wedge test pattern

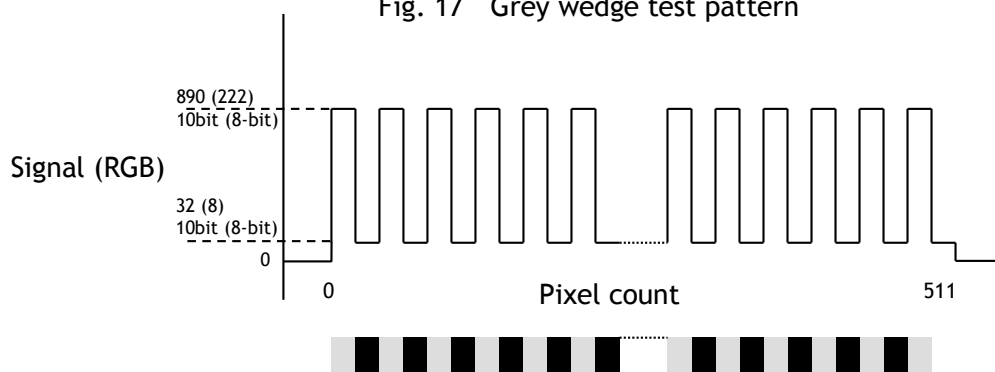

Fig. 18 Grey bars test pattern

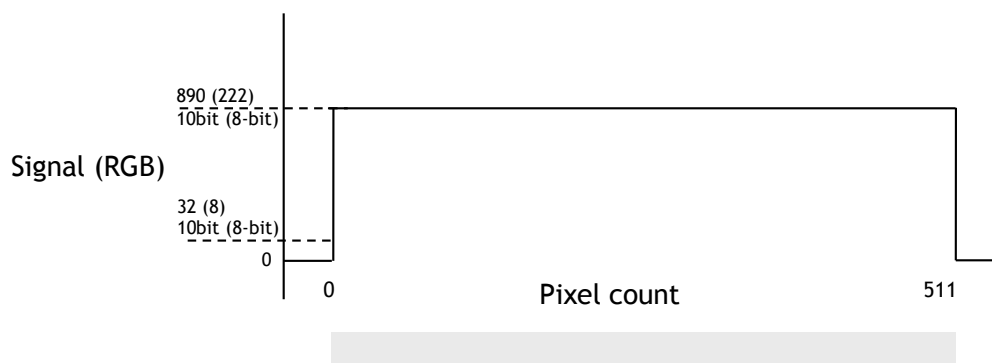

Fig. 19 White level test pattern

8.35 Command **WB** - White Balance

The white balance function can be used for manual setting, One-Push automatic white balance (AWB) and fixed color temperatures (3 selections)

Settings:	0=Manual / On-Push AWB 1=4000K 2=4600K 3=5600K
Applicable modes:	All
Associated functions:	Command AW (Gain) Command AH (Shutter) Command GAR - Manual gain Red channel Command GAB - Manual gain Blue channel
Adjustment range:	One-Push AWB: -6dB to +6dB Manual white balance: -6dB to +6dB

8.36 Factory default settings

Line Rate (LR)	564
Auto LR set (AR)	Ref. 600
Shutter mode (SM)	OFF (SM=0)
Bit allocation (BA)	30 bit (BA=1)
Binning (BI)	OFF (BI=0)
Test Pattern (TS)	OFF (TS=0)
Trigger (TR)	No-Shutter (TR=0)
Trigger Input (TI)	Camera Link (TI= 0)
Trigger Polarity (TP)	Active low (TP=0)
Gain (GA,GAR,GAB)	Master(0), Red(0) ,Blue (0)
White Balance mode (WB)	Manual/One-push Auto AWB (WB=0)
Black level (BL,BLR,BLB)	Master (0), Red (0), Blue (0)
Knee function(KN)	ON (KN=1)
Knee point (KPR,KPG,KPB)	890
Knee Slope (KSR,KSG,KSB)	8192

8.37 Serial communication

The CV-L108CL can communicate by serial communication via the Camera Link connector or via RS232C in the 12-pin Hirose connector. The Baud Rate is fixed at 9600 bps. Switch SW1 at the rear panel of the camera is used to select which way the serial communication is set up.

SW1

No	Function	Setting	
		OFF	ON
1	Select serial communication path	Hirose 12Pin	Camera link
2	External trigger input termination	75 ohm	TTL

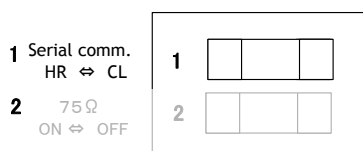

Note: HIROSE 12 Pin and Camera Link can not be used simultaneously.

Communication setting:

Baud Rate	9600
Data Length	8bit
Start Bit	1bit
Stop Bit	1bit
Parity	Non
Xon/Xoff Control	Non

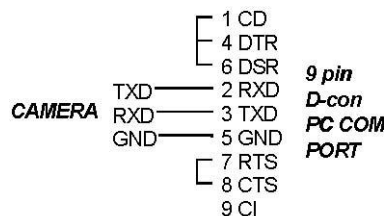

Protocol.

Transmit setting to camera:

NN=[Parameter]<CR><LF> (NN is any kind of command. Capital or small letters.)

The camera answers:

COMPLETE<CR><LF>

To have all communication visible on the emulator screen, start with:

EB=1<CR><LF>

The camera answers:

COMPLETE<CR><LF>

Transmit request command to camera:

NN?<CR><LF> (NN is any kind of command.)

The camera answers:

NN=[Parameter]<CR><LF>

Transmit the following to have the camera actual setting:

ST?<CR><LF>

The camera answers:

A complete list of the current settings

Transmit the following to have a command list:

HP?<CR><LF>

The camera answers:

A list with all commands and possible settings

Invalid parameters send to camera: (99 is an invalid parameter)

SH=99<CR><LF>

The camera answers:

02 Bad Parameters!!<CR><LF>

To see firmware number.

VN?<CR><LF>

To see camera ID. It shows the manufacturing lot number.

ID?<CR><LF>

9 Camera Control Tool for CV-L108CL

From www.jai.com a Camera Control Tool for Windows 2000/XP/Vista can be downloaded. The control tool contains a camera control program and tools for making your own program. For the integrator and experienced user, the Camera Control Tool is much more than a program with a window interface. It also provides an easy and efficient ActiveX interface built for MS Windows 2000/XP/Vista. The OCX interface has the ability to connect to the camera using the serial interface of the PC by reading and writing properties for the camera. This integration requires simple programming skills within Visual Basic, Visual C++ or similar languages in a Microsoft Windows environment.

9.1 Control Tool Windows

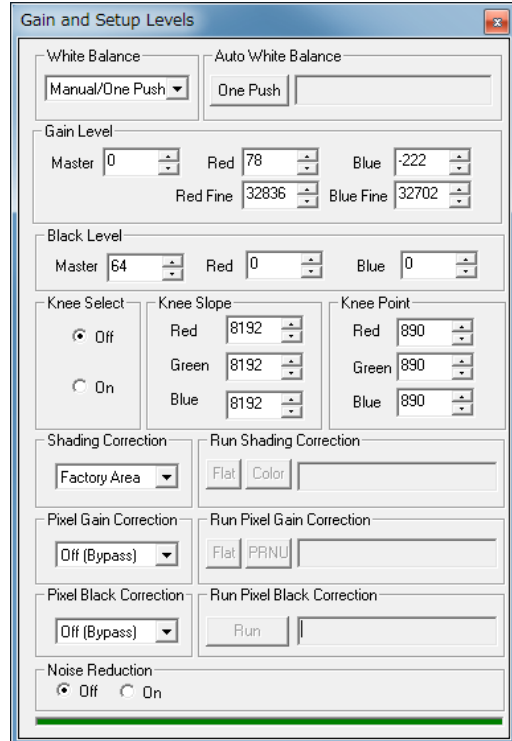
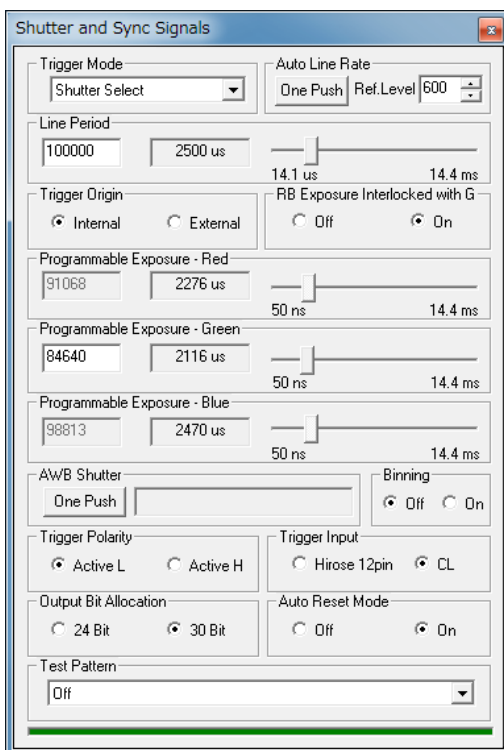
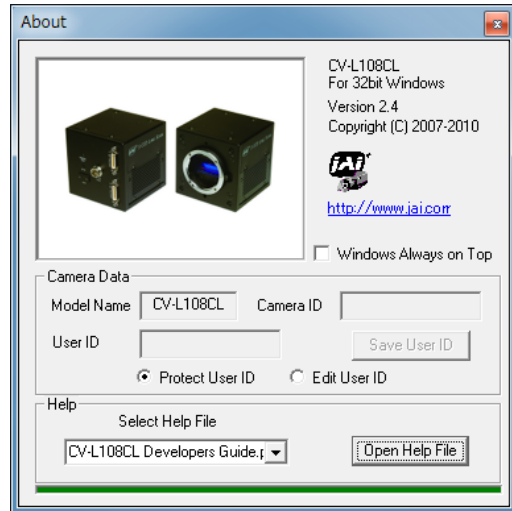
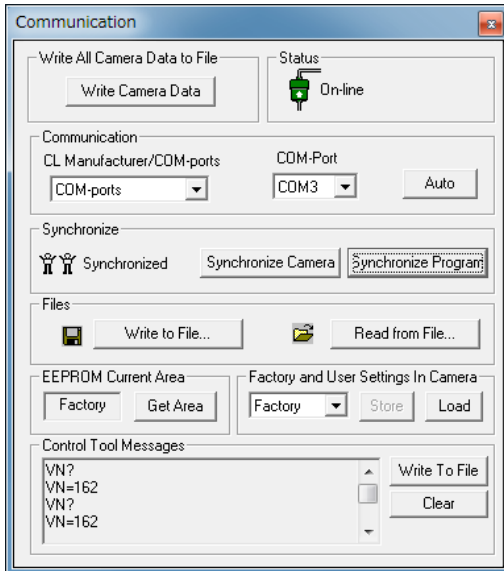

9.2 Camera Control Tool Interface

The Camera Control Tool Software is based on a main Tool Bar and a number of associated Tool Windows. Each button in the Tool Bar pops up a separate Tool Window when pressed. The layout of the program can be adjusted by arranging the windows the way it is preferred. The program will store this information and recreate this layout, when the program is restarted. All Camera Control Tools have a Communication Window and an About Window. The other window(s) contains camera control commands.

The About window

The about window contains a picture of the camera and information about the version of the program, Internet connection to JAI A/S and access to the help documents. The List box that contains the help documents will list all files.

It is possible to download updated operation manuals from the jai website:
<http://www.jai.com>

An updated manual can be saved in the folder address mentioned above .
 For newer camera models the About Window also shows Model Name, camera ID and User ID. It is possible to edit and save free text in User ID.

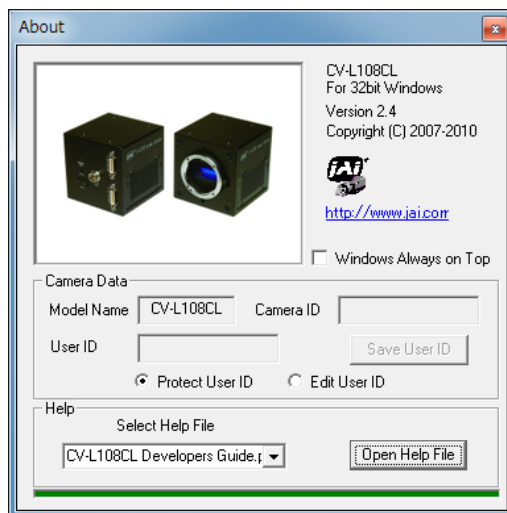

At the bottom of the windows (all windows but the Communication Window is a colored bar. The bar is green when the Camera Control Tool is connected to a camera and the camera is turned on.

The bar is red when the Camera Control Tool is not connected to a camera or when the camera is turned off.

The Communication Window

The Communication Window is used to connect the Camera Control Tool with the JAI camera. Depending on the camera there are 2 possible ways to communicate with a JAI camera.

RS-232:
 Select the communication port, where the serial cable is connected from the list box in the 'Communication Port' field, or click the 'Auto' button to search for a camera on communication port 1 to 16. The camera control program automatically sends a camera request on every communication port. The user is prompted to use a communication port if a camera answers the request.

RS-232 and Camera Link:
 The Communication Window looks a bit different when it is possible to communicate with the camera using Camera Link and RS-232 com port. The Communication area contains 2 list boxes now.

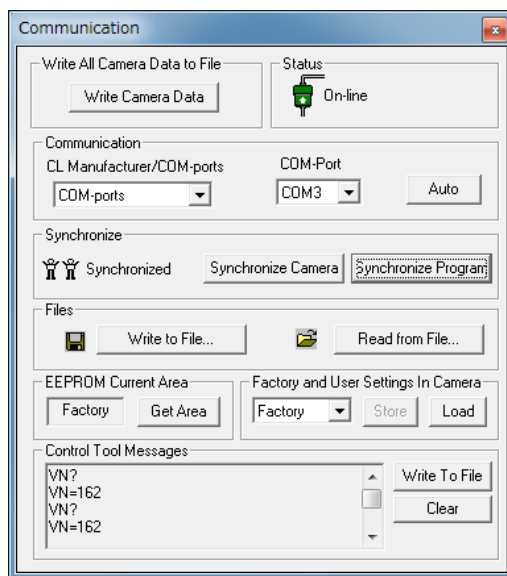

Camera Link Data and RS-232 com port. The

RS-232 communication:

1. Select 'COM-ports' from the 'CL Manufacturer/COM-ports' list Box.
2. Select the communication port, where the serial cable is connected to the camera from the 'Serial Port' list box or click the 'Auto' button to search for a camera on communication port 1 to 16.

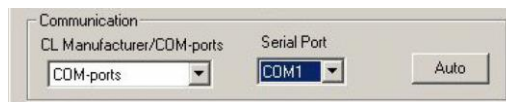

The Serial Port list box and the Auto search button are only active when COM-ports is selected.

Camera Link communication:

The 'CL Manufacturer/COM-ports' list box also contains DLL file names (or frame grabber names) for all Camera Link frame grabbers that are installed in the pc. This is done by using a DLL file called "clserial.dll" to upload all frame grabber DLLs that are found in the pc.

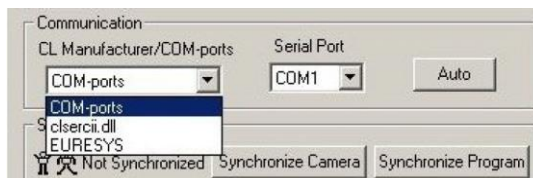

Just select the option for the frame grabber that is installed in the pc.

Auto search

Click the auto button to search for a camera on communication ports 1 to 16. The camera control program automatically sends a camera request on every communication port. The user is prompted to use a communication port if a camera answers the request. This button is only used for RS-232 communication.

Off/On-line mode

The Camera Control Tool Application can run Offline (without a camera attached) and all functions are fully functional in offline mode.

Off line mode is indicated in The Communication Window, where a status field with graphic and text indicates the on/off-line status.

Changing the selected communication port (from the communication window) changes the online/off-line status. If a camera is found on the selected communication port the application runs online otherwise offline.



Changing the settings in the application will automatically update the camera settings when the application is online.

If the application loses connection with the camera it will automatically go to offline mode and it is indicated in the communication window.

Synchronize program and camera

The Camera Control software has the ability to synchronize either the camera or the program. Click Synchronize camera to write all settings from the program to the camera or click the Synchronize program to load all settings from the camera to the program.



Files

When clicking the Write to File or Read from File button, the user is prompted for a file using a standard file dialog. New files are created if they do not already exist.

Files for camera settings have the extension cam. Information about the communication port is not stored in the files. All settings are automatically sent to the camera when a file has been loaded (if the camera is online).

Factory and User Settings

Use the Store button to store the current camera settings into the user settings area in EEPROM. Current camera settings are not saved when the camera is turned off. To save current camera settings you have to save them in the available user areas.

Use the Load button to restore previously saved camera settings from either the Factory or the User EEPROM area.

Write All Camera Data to File.



Click the “Write Camera Data” button to save all camera settings into a text file. The information that can be saved is:

Model Name, Camera ID, User ID, Firmware Version, Current Settings, Factory Settings and the available User Areas.

EEPROM Current Area.

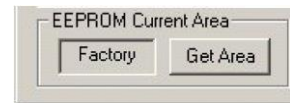

Click the ‘Get Area’ button to read the power up settings area number.

9.3 Using Camera Control Tool

Here is some practical information about the Camera Control Tool:

1. The Camera Control Tool bar is always on top of other windows.
2. When you minimize the Camera Control Tool bar all open windows will close.
3. It is possible to work with the Camera Control Tool when the camera is online and when the camera is offline.
4. The newer JAI cameras always start up with the last used user area (but for some old models it will start up with the last saved user area.)
5. The Camera Control Tool saves the last used settings (not the user area), which don't have to be the same as for the last saved user area.
6. The setup file 'CameraName.ini' stores all information about camera settings. When the program is started, the last settings for the program are loaded from the file 'CameraName.ini'
7. When you turn on the camera and the Camera Control Tool, it is possible that the Camera Control Tool does not show the actual camera settings (see 4. and 5.).
 - a. To obtain the camera settings click “Synchronize Program”.
 - b. To send the settings that are saved in the Camera Control Tool (last used settings) to the camera click “Synchronize Camera”.
 - c. To see which area the camera has started up in click “Get Area”.

10 External appearance and Dimensions

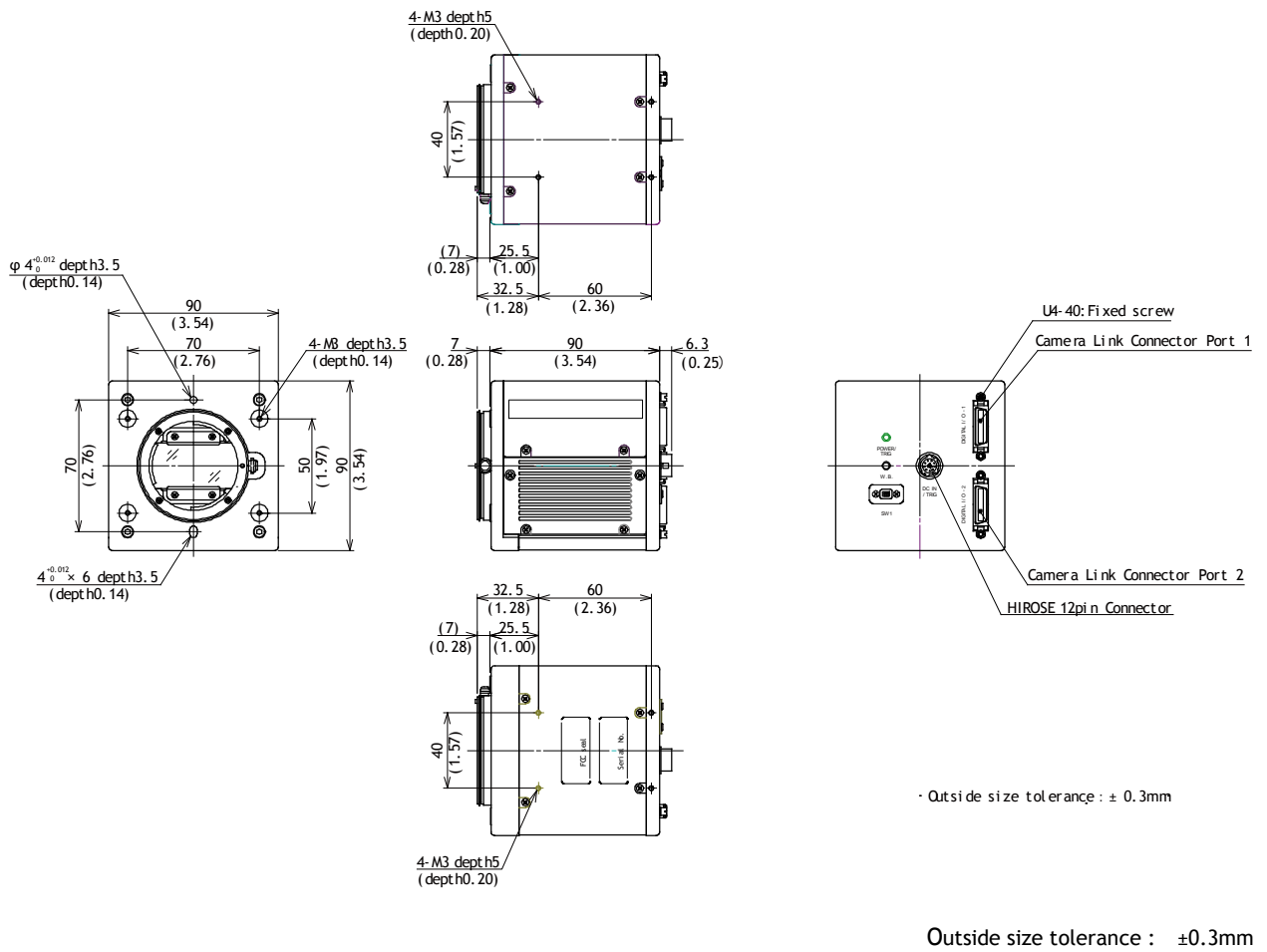

Fig.20 External Appearance and Dimensions

11 Specifications

11.1 Typical data

Scanning system	Line Scan
Pixel clock	40.00 MHz
Line Rate (Standard)	Line rate: 14.10 μ s (No-Shutter mode with Internal trigger) Line Frequency: 70.922 kHz (total number of pixels per line: 564)
Programmable line rate (internal trigger)	Adjustable range: 14.10 μ s(1L) to 14.438 ms(1024L) Increments : 25 ns
Image Sensor	Effective pixels : 512 pixels Pixel Size : 14.0 μ m \times 14.0 μ m Effective image length : 7.168 mm
Sensitivity of sensor	Radiometric: 27nJ / cm ²
Sensitivity on sensor	162 lux (4000K) (Line rate:600 μ s, Gain=0dB,Shutter =OFF, 100% video)
S/N	58 dB (Green channel, Gain=-3dB)
Video output	Digital 8-Bit x 3 or 10-Bit x 3 (Camera link)
Gain range	Master(Green): -3dB to +12dB
White balance	Adjustable range : 2800K to 9000K Standard color temperature : 4000K
Flat field correction	Corrects for pixel response non-uniformity and pixel dark signal non-uniformity (FPN) - (individual pixel, two-point correction)
Shading correction	Corrects for shading caused by illumination or lens vignetting. Can also be configured to compensate for chromatic shading.
Knee control	Slope and Knee point compensation
Electronic shutter	Available for Shutter-Select and Pulse Width Control (PWC) modes Adjustable range : 50ns(2 clk) to 14.483ms (Note 1) Adjustment increments : 25ns(1 clk)
Binning	Horizontal binning
Global Black level	Master Reference : 32(8) LSB (Note 2) Adjustable range :-64 to 64(16) LSB (Note 2)
Test pattern generator	Color bar, gray 1, 2 and white, 890 LSB
Synchronization	By external trigger pulse, or internal clock
Operation mode	No-Shutter, Shutter-Select, Pulse Width Control (PWC)
Trigger input	Hirose12Pin : 4.0 \pm 2.0Vp-p TTL or Camera link : LVDS (CC1) Possible to change Negative Logic or Positive Logic Minimum trigger width : more than 500ns(SHUTTER-SELECT) I, 50 μ s(PWC)

CV-L108CL

Sync output (open termination)	Camera link LVAL, DVAL, EEN Hirose 12Pin XEEN (Negative logic) 4.0 Vp-p (no termination)
Communication interface	Via Camera Link connector or RS-232C (Hirose 12-Pin connector) Baud rate : 9600bps Interface is switched by SW1 located rear panel. Camera Link and Hirose 12P cannot be used at the same time.
Power	DC +12V±10% 1100mA (max 1200mA) Note: Use a power supply capable of providing more than 3A.
Lens Mount	Nikon F-Mount Maximum allowed rear protrusion on lenses: Nikon F-Mount: 13 mm
Flange back	Nikon F-Mount : 46.5mm tolerance: 0 ~ -0.05mm
Optical axis	Center ±0.1mm(Max)
Operating temperature /Humidity	- 5°C to +45°C / 20 to80% (non-condensing)
Storage temperature /humidity	-25°C to +60°C, 20 to 80% (non-condensing)
Vibration	3G (20Hz to 200Hz XYZ direction)
Shock	50G
Regulation	CE (EN61000-6-2+EN61000-6-3) IEC61000-4-2 Conforming to Level 4 (Note 3) FCC Part15 Class B RoHS
Dimensions	90(W) x 90(H) x 90(D) mm (without connector and lens mount protrusion)
Weight	830 g (Both F-Mount and P-Mount)
Connectors	Camera Link : 10226-1A10JL x2 Hirose 12Pin : HR10A-10R-12PB

Note 1: This is maximum accumulation time at minimum line cycle (14.10 μs)
If the line rate is set at 14.438ms, the maximum accumulation is 14.438 ms.
The maximum accumulation depends on the line rate setting (Shutter-select/Internal
trigger) or the trigger interval (Shutter-select/External).

Note 2: LSB numbers shown in parentheses are for 8 bit output.

Note 3: This is effective only when specified connector or cable is used.
Refer to chapter 5. Connectors.

11.2 Spectral sensitivity

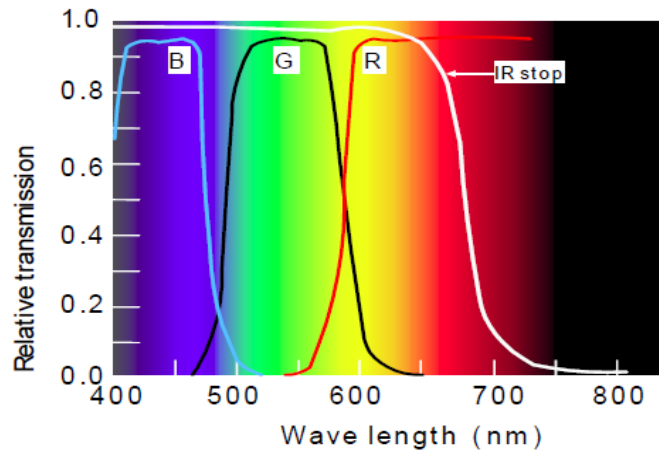

Fig. 21 Spectral Response

12 Appendix

12.1 Precautions

Personnel not trained in dealing with similar electronic devices should not service this camera. The camera contains components sensitive to electrostatic discharge. The handling of these devices should follow the requirements of electrostatic sensitive components.

Do not attempt to disassemble this camera.

Do not expose this camera to rain or moisture.

Do not face this camera towards the sun, extreme bright light or light reflecting objects.

When this camera is not in use, put the supplied protective cap on the lens mount.

Handle this camera with the maximum care.

Operate this camera only from the type of power source indicated on the camera.

Remove power from the camera when changing switch settings.

12.2 Typical Sensor Characteristics

The image sensors used in the CV-L108CL have been chosen for their superior performance. There may, however, always be artifacts visible in the scanned image originating from pixel imperfections in the camera. The Pixel Gain and Pixel Black correction functions will allow the user to compensate for such artifacts, producing an essentially “flat” image.

12.3. Caution when mounting a lens on the camera

When mounting a lens on the camera dust particles in the air may settle on the surface of the lens or the image sensor of the camera. It is therefore important to keep the protective caps on the lens and on the camera until the lens is mounted. Point the lens mount of the camera downward to prevent dust particles from landing on the optical surfaces of the camera. This work should be done in a dust free environment. Do not touch any of the optical surfaces of the camera or the lens.

12.4. Exportation

When exporting this product, please follow the export regulation of your own country.

12.5 References

1. This manual for CV-L108CL can be downloaded from www.jai.com
2. Datasheet for CV-L108CL can be downloaded from www.jai.com
3. The camera control software can be downloaded from www.jai.com

User's Record

Camera type: CV-L108CL
Revision:
Serial No.
Firmware version.

For camera revision history, please contact your local JAI distributor.

User's Mode Settings.

User's Modifications.

Company and product names mentioned in this manual are trademarks or registered trademarks of their respective owners. JAI A-S cannot be held responsible for any technical or typographical errors and reserves the right to make changes to products and documentation without prior notification.

Europe, Middle East & Africa

*Phone +45 4457 8888
Fax +45 4491 3252*

Asia Pacific

*Phone +81 45 440 0154
Fax +81 45 440 0166*

Americas

*Phone (toll-free) +1 800 445 5444
Phone +1 408 383 0300*

Visit our web site at www.jai.com



See the possibilities