

TECHNICAL AUDIO DEVICES LABORATORIES, INC.

TAD

TAD Reference One

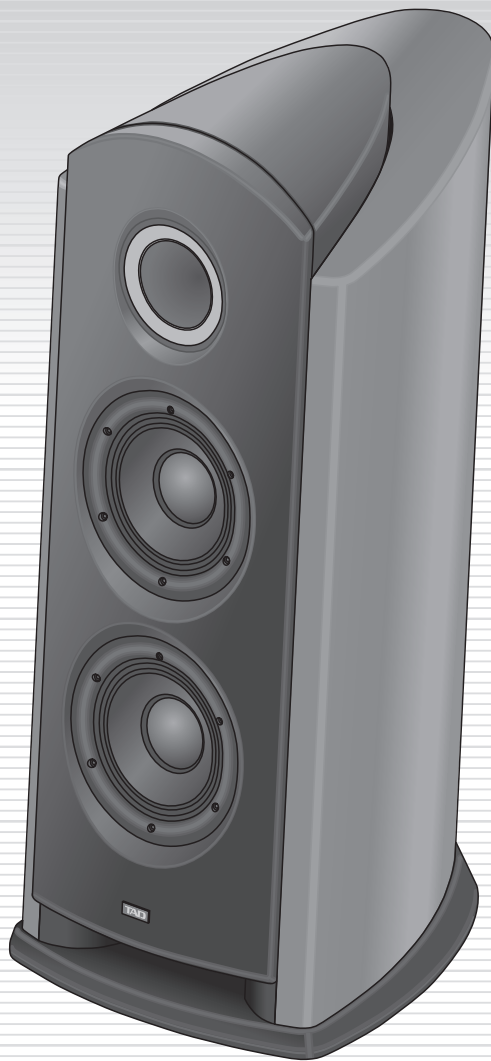

**TAD-R1 SPEAKER SYSTEM
OWNER'S MANUAL**

WARNING: Handling the cord on this product or cords associated with accessories sold with the product may expose you to chemicals listed on proposition 65 known to the State of California and other governmental entities to cause cancer and birth defect or other reproductive harm.

Wash hands after handling.

D36-P5_B1_En



If you want to dispose this product, do not mix it with general household waste. There is a separate collection system for used electronic products in accordance with legislation that requires proper treatment, recovery and recycling.

Private households in the member states of the EU, in Switzerland and Norway may return their used electronic products free of charge to designated collection facilities or to a retailer (if you purchase a similar new one).

For countries not mentioned above, please contact your local authorities for the correct method of disposal.

By doing so you will ensure that your disposed product undergoes the necessary treatment, recovery and recycling and thus prevent potential negative effects on the environment and human health.

K058b_A1_En

BEFORE YOU START



Contents

INTRODUCTION.....	4	CONNECTING THE LOUDSPEAKERS	12
TAD History.....	4	Single-Wire Connections.....	12
TAD Reference One Description	4	Bi-Wire Connections	13
About The Manual And Warranty	4	Bi-Amplification Connections.....	14
		Vertical Bi-Amping.....	14
		Horizontal Bi-Amping	15
TECHNOLOGY	5	OPTIMIZING THE SYSTEM.....	16
Beryllium Diaphragms	5	Improving Bass Performance	16
CST.....	5	Improving Imaging.....	16
Bass Drivers.....	6	Final Optimization.....	16
CST Mounting Construction.....	7		
Bass Enclosure Construction.....	7	LOUDSPEAKER CARE	17
Crossover Networks	7	SPECIFICATIONS	18
Enclosure Finish.....	7	DEAR CUSTOMER.....	19
INSTALLATION AND PLACEMENT	8		
Concerning The Placement Of This Unit	8		
Installing The Spikes	9		
Removing The Grille Covers.....	9		
Choosing Where To Place The Loudspeakers ..	10		

Parts included

Check that the following items are located in the accessory kit:

- Shorting links x 2
- Cone-shaped spikes x 3
- Round spikes x 3
- Cleaning cloth x 1
- Hex wrench x 1
- This Owner's Manual x 1
- Guide to unpacking unit x 1 (Attached to exterior of packaging)

Note: Included parts may vary slightly by region.

INTRODUCTION

TAD History

Founded in 1975, Technical Audio Devices (TAD) has continued to stand at the frontier of cutting-edge sound technology, maintaining a well-established tradition of creating high performance speakers for professional use. TAD products are designed, crafted, and produced with strict adherence to the most rigorous standards demanded by musicians and professional audio-system designers around the world.

TAD loudspeaker components are found in studio monitors, sound reinforcement systems, public address and concert hall speakers, cinema theater audio systems, and many other applications that require the highest-quality sound reproduction.

With this high standard of quality, world-class recording studios rely on TAD components for original recordings and digital remastering of audio performances. In recent years, TAD has met the demand for high-quality home audio speakers by delivering world class audio components that carry the TAD pedigree into the home.

TAD Reference One Description

The TAD Reference One loudspeaker is a breakthrough product for the home audio market, and represents the culmination of over 30 years experience in developing class-leading loudspeakers for the professional studio monitoring environment. Central to the performance of the TAD Reference One loudspeaker is the Coherent Source Transducer (CST), a concentric unit featuring TAD's unique beryllium-diaphragm design. Beryllium is used for both the tweeter dome and the midrange cone, to provide a point source radiator covering the frequency range from 250 Hz to 100 kHz.

The CST is supplemented by dual 25 cm (10 in.) bass drivers enclosed in structurally inert cabinet. The result is a very wide-band, resonance-free monitor loudspeaker of the highest quality.

About The Manual And Warranty

To obtain optimum performance from this product, please carefully read the remaining pages of this owner's manual, along with manuals of other components in your system. To register for warranty support, please fill out and mail the enclosed warranty card.

Beryllium Diaphragms

Each TAD Reference One loudspeaker features proprietary beryllium-manufacturing technology for the midrange and tweeter diaphragms. The lightest and most rigid metal available for diaphragms, beryllium performs with strength and damping characteristics unmatched by any of the materials currently used in high-end audio loudspeaker manufacturing, as shown in Figure 1. Beryllium’s combination of light weight and exceptional strength enables diaphragm resonance to be pushed far beyond the operating band of its drive units. This produces near-perfect piston behavior in the speakers, resulting in cleaner sound and greater accuracy of reproduction.

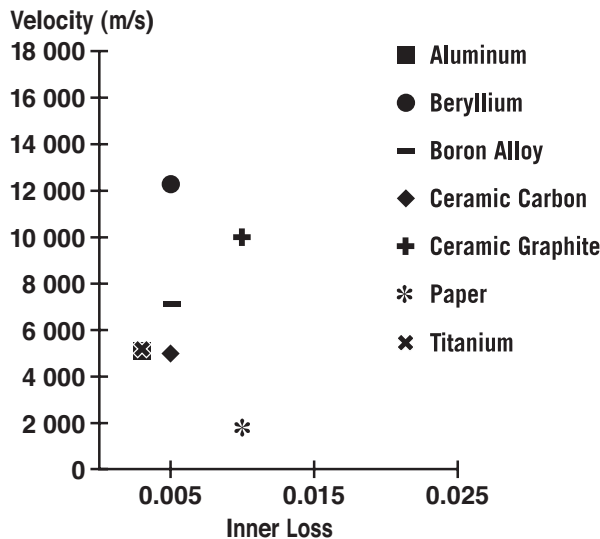

Figure 1. Velocity properties of beryllium and other materials.

CST

The heart of the system is the Coherent Source Transducer (CST), shown in Figure 2. The tweeter diaphragm is mounted concentrically within the apex of the midrange cone and provides a point source of sound from 250 Hz to 100 kHz. It is time coherent, due to the shallow midrange-cone profile made possible by the superior strength of beryllium, and produces a superbly-controlled radiation pattern. CST ensures a perfect spectral balance between the direct and reflected sounds that arrive at the listener’s ears, providing a more consistent sound throughout the listening room and improved imaging capability.

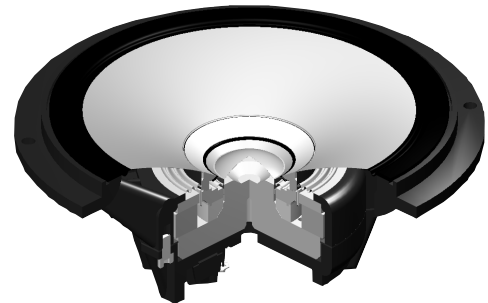

Figure 2. The TAD Reference One’s Coherent Source Transducer

Bass Drivers

The foundation of the TAD Reference One loudspeaker is the bass drivers, as shown in Figure 3. The driver cones are constructed from a tri-laminate of front and rear-woven aramid fibers that sandwich a foamed acrylic core. This provides enormous strength to the cone in order to resist any flexing due to the high forces exerted during loud bass passages.

To achieve high drive linearity, the motor structure employs short coil and long gap geometry, Faraday shorting rings, and a novel flux path for even lower distortion. Combined with advanced spider and multi-roll surround design, the bass driver has over 30 mm (1.25 in.) of linear drive capability, as shown in Figure 4.

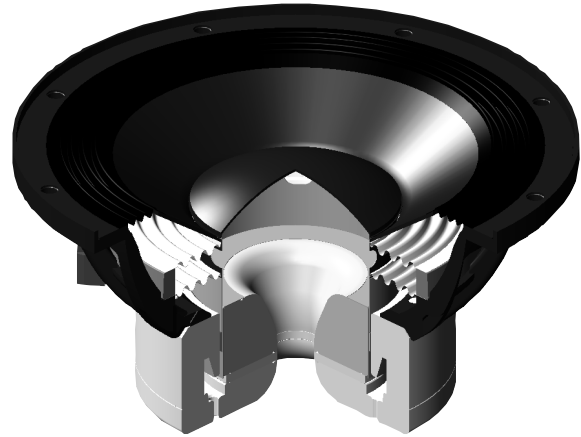

Figure 3. The TAD Reference One's Bass Drivers.

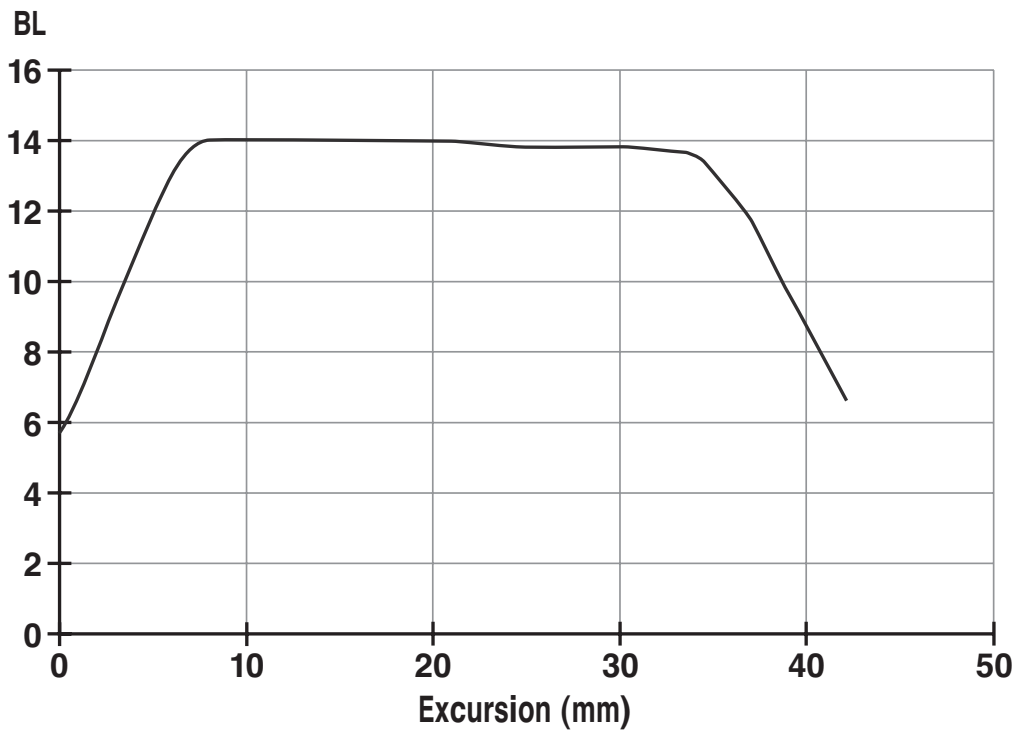

Figure 4. BL versus excursion for the TAD Reference One's bass driver.

CST Mounting Construction

The CST driver is mounted into an extremely firm enclosure that features a headboard specially formed to optimize the sound emitted from the driver. To further enhance the performance, ISO-Drive technology is used to mechanically isolate the CST driver from its mounting. This greatly reduces the mechanical energy that is the source for enclosure vibration, resulting in reduced delayed resonances and improved resolution of fine detail.

Bass Enclosure Construction

The enclosure of the TAD Reference One's bass drivers features a frame of 21 mm (0.9 in.) thick laminated birch plywood supported by a CNC processed plywood back board “spine” up to 137 mm (5.7 in.) thick, clad with 50 mm (2 in.) curved side panels created by high-frequency heating. The bass reflex port was modeled after the design concept of the TAD compression driver and horn, resulting in the reduction of wind noise for clear, deep bass. In order to fully realize the drive unit's potential, the drivers are securely mounted to the enclosure and the enclosure is slanted at a four-degree tilt back, optimizing the unit's center of balance. The 150 kg (330 lb) mass of this system produces a correspondingly powerful bass sound that is both clean and subtle. The teardrop-shape both reduces sound diffraction, allowing for excellent acoustics, and also serves to eliminate unnecessary resonance and internal standing waves.

Crossover Networks

The crossover networks use only the finest components. Air cored coils, noninductive resistors, and film capacitors in the signal path are all carefully chosen and optimized for the CST driver to provide the greatest transparency to the signal. The bass drivers use laminated steel-core inductors for highpower handling and low saturation. All components are built on high-grade, glass-epoxy, printed circuit boards with thick copper traces to ensure stability and repeatability of performance.

Enclosure Finish

The enclosure features rare, elegant natural wood that is treated with a transparent finish. Its surface has a beautifully polished mirrored finish, the result of the meticulous, painstaking work of skilled craftsmen.

This product is designed to elicit the full potential of the natural wood used in its enclosure. Note that the color and pattern of the wood is slightly different for each unit.

INSTALLATION AND PLACEMENT

Caution: About installation

This unit is sold with the understanding that it is to be installed by a properly trained and equipped specialist. All matters concerning installation and mounting should be handled by specialists or by your local dealer.

Technical Audio Devices Laboratories, Inc. waives all responsibility for damages to this unit as the result of improper installation/mounting, improper use, remodeling/alteration, and natural disasters.

Caution: About the placement of this unit

This product weighs 150 kg (330 lb). Make sure that you place this product upon a surface that can easily sustain this weight. Additionally, note that when using spikes, each spike supports some 50 kg (110 lb), and as such may cause damage to flooring underneath a carpet or other surfaces. To avoid causing such damage, be sure to place a sufficiently large and strong cushion underneath each spike.

As a precautionary measure, be sure to not place the unit anywhere where it might fall on a sleeping individual in the event of an earthquake.

Concerning The Placement Of This Unit

There is an aluminum plate attached to the bottom of the unit's cabinet. It can be placed normally upon a flat surface. This unit comes with two types of spikes that you can use to adjust the unit to the shape of the floor for best possible placement.

We recommend the following placement methods:

For flat surfaces: no spikes

Thick carpet or mat: cone-shaped spikes

Thin carpet or mat: round spikes

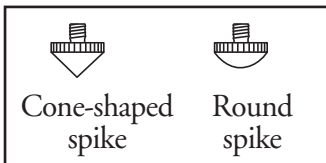

Installing The Spikes

WARNING!



Be sure to use two people when installing the spikes. Be careful to not pinch your fingers under the loudspeaker and make sure the loudspeaker does not fall on its side.

The installation of spikes on the bottom of the unit allows you to establish a firm connection between the ground and the loudspeaker when placing the loudspeaker on uneven surfaces. The bottom of the cabinet features three areas for these spikes.

The use of three spikes for support eliminates the need for fine adjustments, allowing you to keep the loudspeaker firmly in place. See *Choosing Where To Place The Loudspeakers* on page 10 for help deciding where to place the loudspeaker, and Figure 5 for how to install the spikes.

There are screw holes on the aluminum plates located on the bottom of the cabinets.

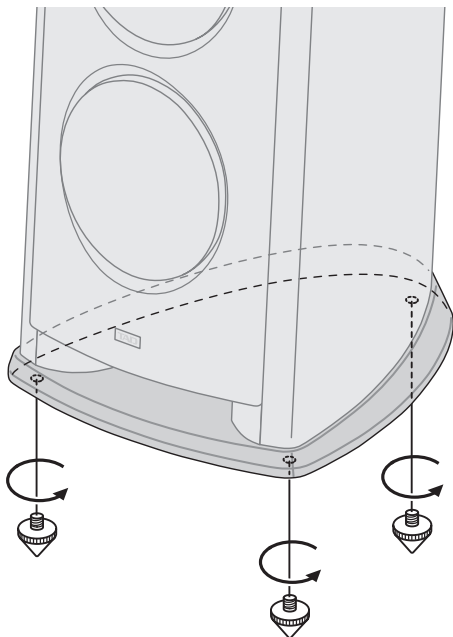

Figure 5. Installing the spikes

Removing The Grille Covers

The bass drivers come equipped with grille covers that should be removed when the loudspeakers are in use (see Figure 6). To remove them, grasp each grille along the edges, pull it out, and store it in a safe place in case of future use when moving or storing this unit.

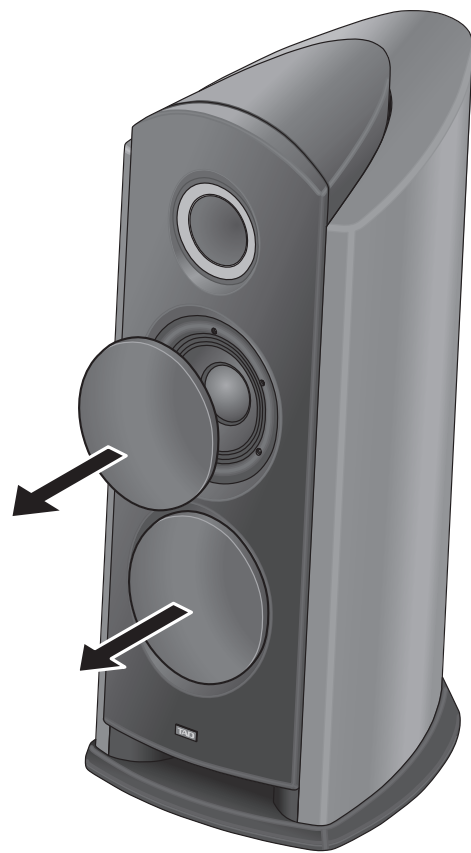

Figure 6. Removing the grille from the TAD Reference One loudspeaker

Choosing Where To Place The Loudspeakers

Loudspeaker placement within the listening room will have a great impact upon the total performance of TAD Reference One loudspeakers in terms of bass performance, tonal accuracy, and imaging. All rooms are different and so this section is intended as a guide only. Experimentation in your room will yield optimum results.

Begin by placing the rear of the loudspeakers approximately one to two feet in from the front walls and the sides one to two feet in from the side walls of your listening room, as shown in Figure 7. Your listening position should be roughly equal to the distance between the two loudspeakers. Also, turn the loudspeakers inward so each axis points toward the listening position.

Next, connect the audio system as described in *CONNECTING THE LOUDSPEAKERS* on the next page. Then, optimize the loudspeaker placement as described in *OPTIMIZING THE SYSTEM* on page 16.

WARNING!



Keeping the spikes inserted can cause damage to the bottom of the unit in the event that you move the loudspeaker. Be sure to remove the spikes before moving the loudspeaker to another location.

In order to protect the bottom of the unit from damage when moving the loudspeaker, you should place a thick cloth or mat beneath the system before moving it to a new location.

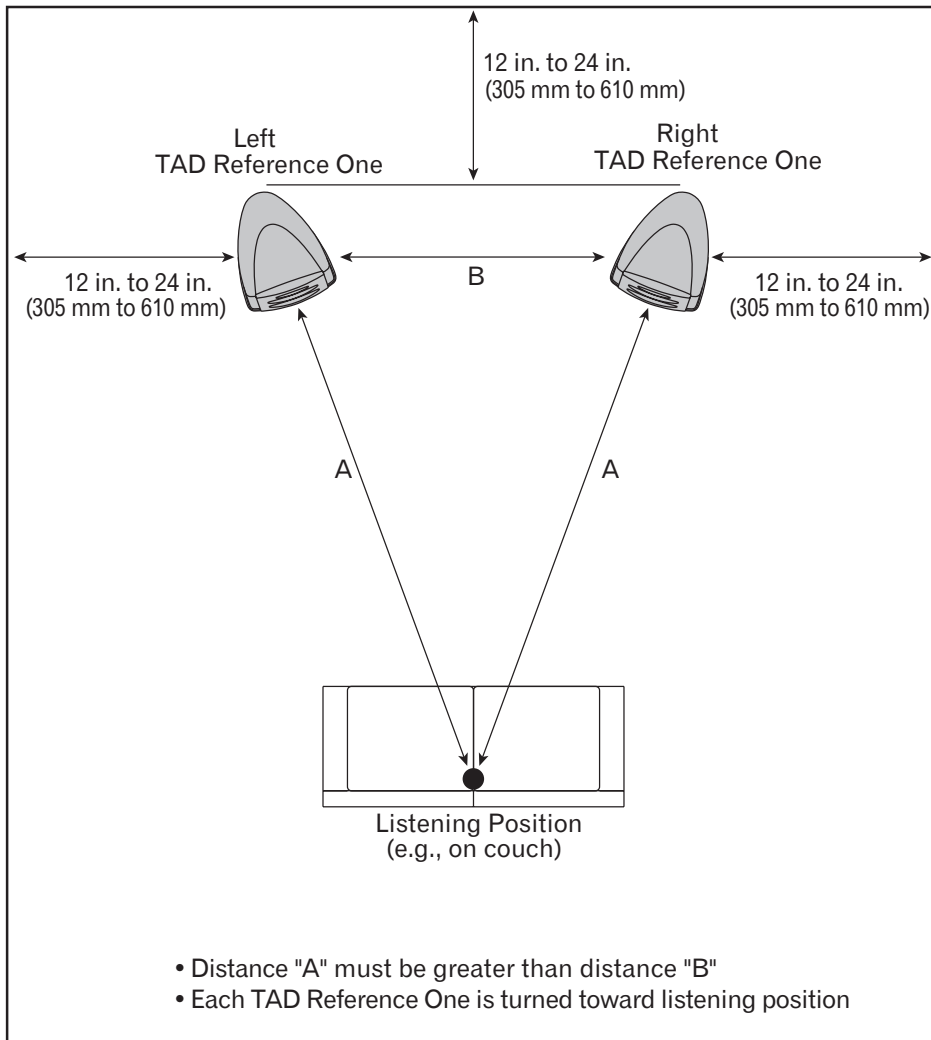

Figure 7. Placement of a pair of TAD Reference One Loudspeakers for stereo music listening.

CONNECTING THE LOUDSPEAKERS

Single-Wire Connections

For single-wire connections, connect the high- and low-frequency sections of the crossover network with the shorting link that was included with this unit, then connect the (+) wire from your amplifier to either red binding post and the (-) wire from your amplifier to either black binding post, as shown in Figure 8.

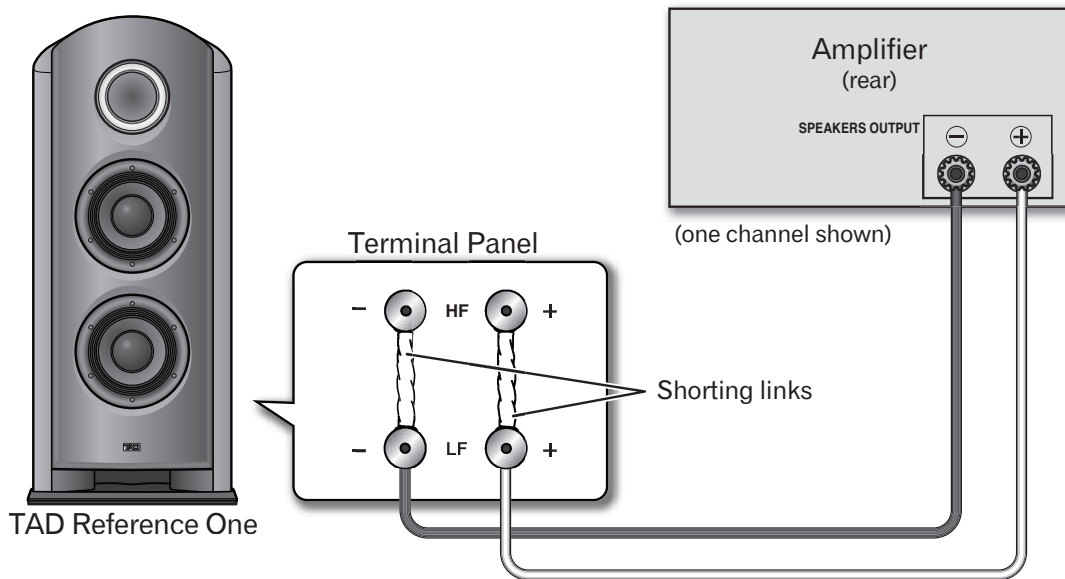

Figure 8. Connecting a TAD Reference One loudspeaker in a single-wired system.

Bi-Wire Connections

In a bi-wiring connection, you independently plug in the loudspeakers running from the amp to their respective high- and low-frequency plugs. This results in the CST driver and bass drivers being independently connected directly to the amplifier, offering you the freedom to optimize the cable type for each of the drivers. Connect one set of wires to the bottom set of binding posts (bass driver-specific network). Then connect a second set of wires to the top binding posts (CST-specific network). Next, connect both sets of wires to the appropriate terminals on your amplifier. Take care to connect both (+) wires to the (+) amplifier terminals and both (-) wires to the (-) amplifier terminals, as shown in Figure 9.

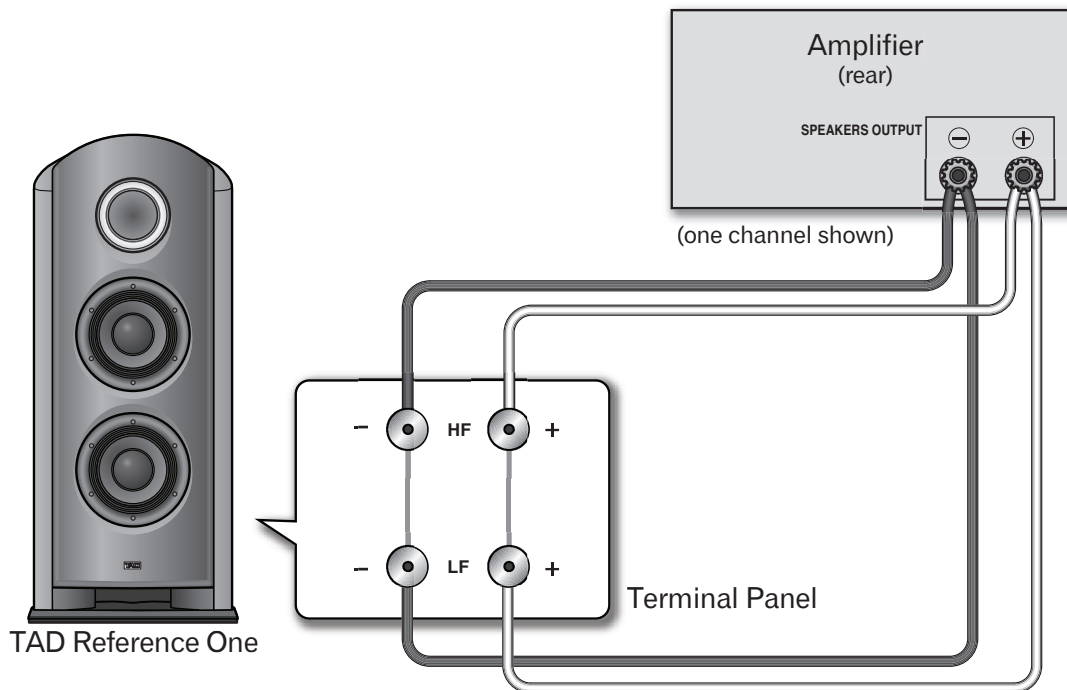

Figure 9. Connecting a TAD Reference One loudspeaker in a bi-wired system.

Bi-Amplification Connections



Bi-Amplification allows the best performance from the TAD Reference One loudspeaker by using dedicated amplifiers for low- and high-frequency sections. There are two possible configurations, commonly referred to as horizontal and vertical bi-amping.

WARNING:

Remove the shorting links before connecting speaker cables in bi-wiring connections. Failure to do so may result in damage to your amplifiers.

Vertical Bi-Amping

With this configuration, identical stereo amplifiers are used for each loudspeaker. One channel of each amplifier drives the low frequency section and the other channel drives the high frequency section, as shown in Figure 10. Connect one set of wires and amplifier channel to the bottom set of binding posts (bass driver-specific network). Then connect a second set of wires and the other amplifier channel to the top binding posts (CST-specific network). Take care to connect both (+) wires to the (+) amplifier terminals and both (–) wires to the (–) amplifier terminals.

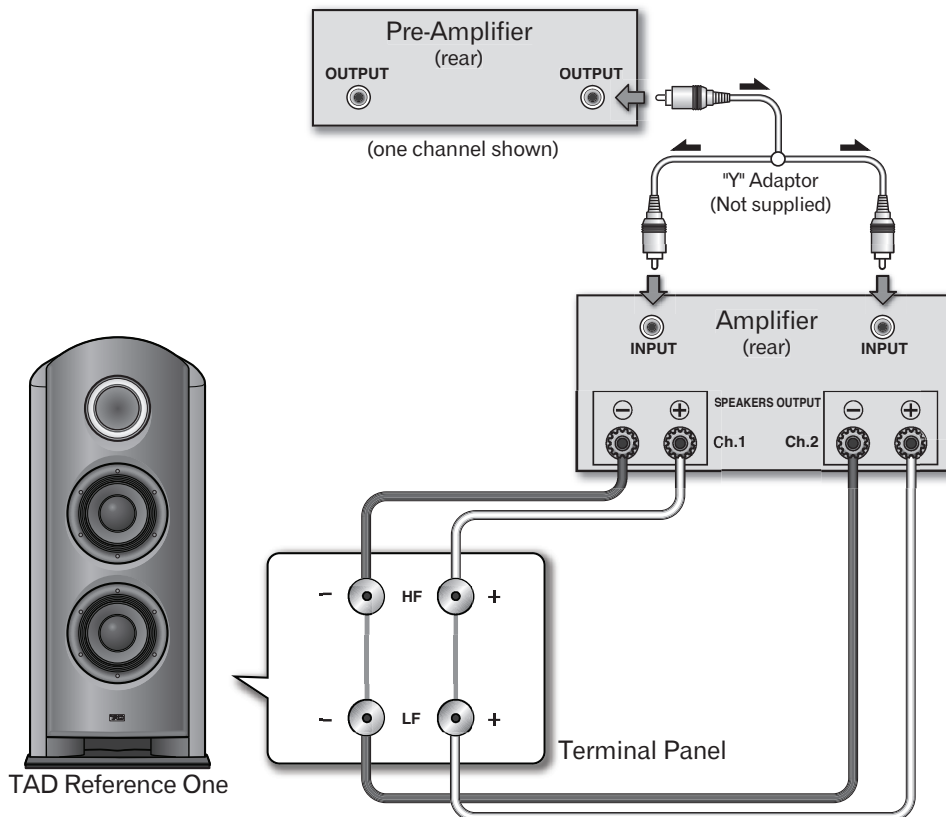

Figure 10. Connecting a TAD Reference One loudspeaker in a vertical bi-amplified system.

Horizontal Bi-Amping

With this configuration, you may use different stereo amplifiers for the low- and high-frequency sections of the loudspeaker (e.g., tube amplifiers for high frequency and solid state for low frequency). Each channel of one amplifier drives the low-frequency section of each loudspeaker and each channel of the other amplifier drives the high-frequency section, as shown in Figure 11.

This method requires that both amplifiers have the same gain; otherwise an imbalance will be heard between the low- and high-frequency reproduction from the loudspeaker. If in doubt, please consult your TAD dealer.

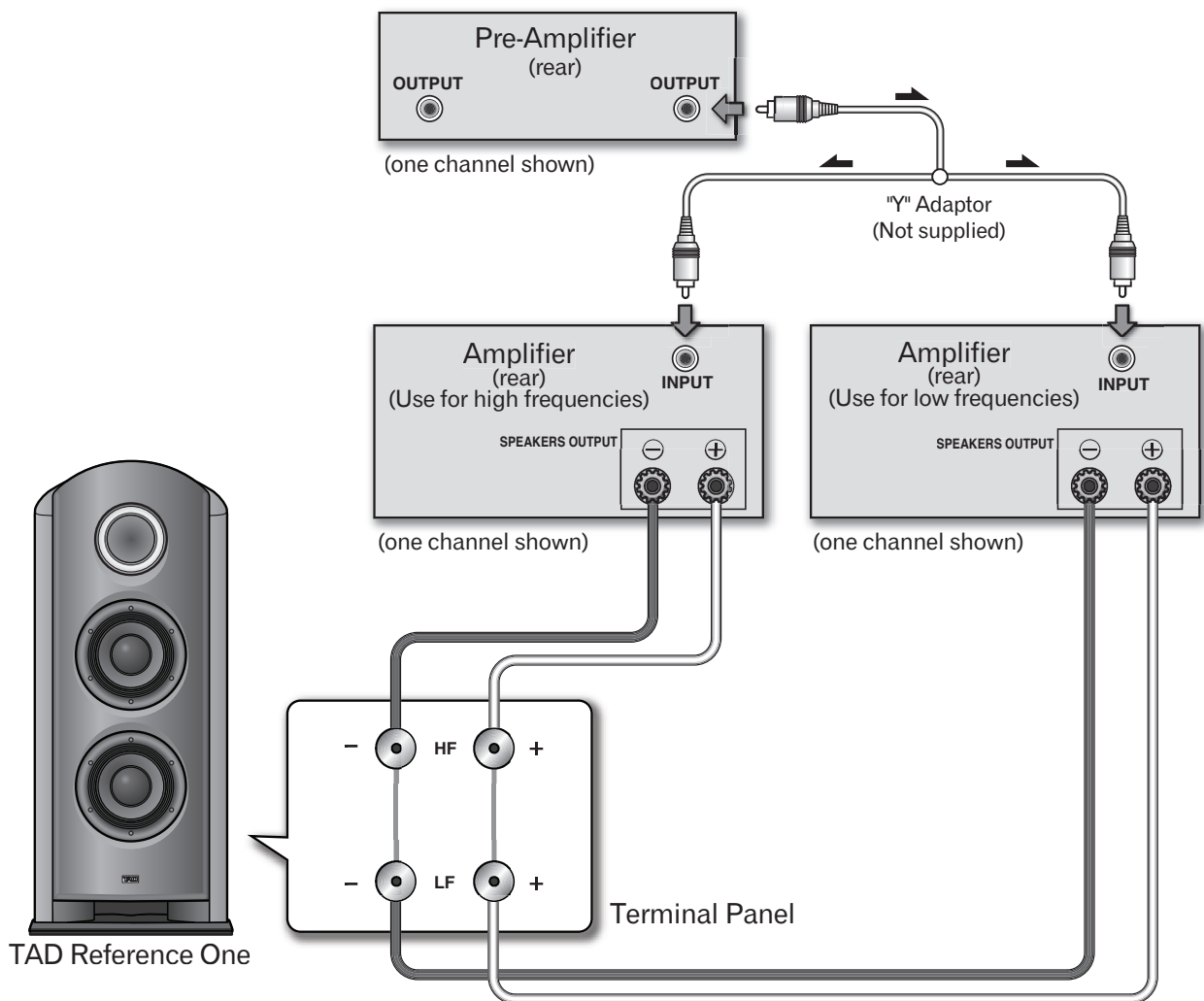

Figure 11. Connecting a TAD Reference One loudspeaker in a horizontal bi-amplified system.

OPTIMIZING THE SYSTEM

Improving Bass Performance

Select a music track with well-recorded bass, such as acoustic string bass. Listen for all the bass notes having roughly equal level. If any notes jump out at you more strongly than others, try moving the TAD Reference One loudspeakers until you get the most even progression of the notes.

Typically, moving them towards the walls will increase low bass output, but can result in more unevenness higher up the musical scale. Moving them closer to the side walls will not produce the same effect as moving closer to the back wall, so try experimenting moving both ways for the most pleasing sound.

Also listen to drum sounds. The kick drum should sound tight and fast, without low-frequency boom. Changes in loudspeaker position of as little as a few inches can have a large effect upon bass performance, so take time and try many positions.

A useful tip to speed up the process is to have a partner move around the room while talking. Listen to where the voice sounds most natural, without added chestiness, and position the loudspeaker in that location.

Improving Imaging

Now select music with a strong center image. Listen for that image to be exactly centered between the loudspeakers, and to be well-focused. If the image is unclear and spreads wide, the side walls are probably creating strong reflections. Try moving the loudspeakers closer together to reduce this effect. If this brings them too close, try instead toeing in the loudspeakers so that the axis crosses in front of the listening position. Because of the superior off-axis

performance of the CST driver, the strength of the side-wall reflections will be reduced, and at the same time, the image will be stabilized and focused.

Now listen to music with well-recorded acoustics. Check that the image is wide and deep. Limited depth suggests that the speakers are placed too close to the front wall. Try moving them forward.

Final Optimization

You may find that as you move the loudspeakers to optimize one aspect of performance another worsens; for example, trading improved image accuracy for poorer bass response. If this occurs, try moving your listening position. Bass response is governed strongly by both loudspeaker and listening positions, whereas imaging is mostly determined by the loudspeaker position. Therefore, you may find that if optimizing for imaging compromises bass, then changing the listening position will bring back bass performance.

The room characteristics will also have a profound influence upon the sound. *Live* rooms, with few soft furnishings and hard floors, will impart an artificial sense of spaciousness to the sound but reduce the intimacy and accuracy. Overly *dead* rooms, with lots of furnishing, carpets, and drapes will produce a very dry, lifeless sound and require lots more power to drive the loudspeakers to adequate sound levels. The optimum is somewhere in-between. Avoid hard, unbroken, parallel walls, especially side walls, as these impart strong flutter-type echoes and will have a bad influence on the imaging. Try and break up long expanses of walls with drapes, wall hangings, or bookshelves, and try not to introduce too much asymmetry into the room layout, as this will also affect the imaging.

Each TAD Reference One loudspeaker has a polymer finish that requires care similar to a grand piano. For accumulated dust and fingerprints, simply wipe the cabinet with the included cleaning cloth.



CAUTION: Do not use any cleaners or polishes on the cabinet or grille!

In areas of high humidity, use a dehumidifier, and in areas of excessive dryness, use a humidifier to adjust the room's humidity level. Avoid exposure to direct sunlight, and do not install in areas near by heating appliances.

Conditions considered unpleasant by humans are detrimental to speakers as well. Providing a comfortable environment for the speakers will assist them in demonstrating their best performance. Please maintain the usage environment as follows:

Temperature: 15 °C to 25 °C

Relative Humidity: 35 % to 65 % (winter)

40 % to 70 % (summer)

When using room air-conditioners or stoves to rapidly cool or heat room spaces, take precautions to avoid excessive dehumidification.

Do not try to force a low-powered amplifier to produce loud volumes of sound (the amplifier's harmonic distortion will be increased, and you may damage the speaker).

SPECIFICATIONS

Model Name

TAD Reference One

Model No.

TAD-R1

Design

3-way vented box

Drive units

Bass driver 25 cm (10 in.) cone x2

Midrange/Tweeter concentric
16 cm (6 1/2 in.) cone/ 3.5 cm (1 3/8 in.) dome

Performance Data

Frequency Range.....21 Hz to 100 kHz (-10 dB)

25 Hz to 20 kHz, ±3 dB; frontal average response

Crossover Frequencies.....250 Hz, and 2 kHz

Amplifier Requirements 50 W to 300 W

Sensitivity

.....90 dB @ 2.83 V and 1 m (anechoic conditions)

Maximum Output 115 dB

Nominal Impedance.....4 ohms (minimum 4.1 ohms)

Physical Data

Weight.....150 kg (330 lb)

Dimensions

Height 1293 mm (50 7/8 in.)

Width 554 mm (21 13/16 in.)

Depth 698 mm (27 1/2 in.)

Supplied accessories

Guide to unpacking unit (Attached to exterior of packaging)

Accessory kit

- Cleaning cloth x 1
- Shorting links x 2
- Cone-shaped spikes x 3
- Round spikes x 3
- Hex wrench x 1
- This Owner's Manual x 1

Note: Included parts may vary slightly by region.

The specifications and construction details in this and related TAD publications are subject to change without notice. The TAD logo is a registered trademark of Technical Audio Devices Laboratories, Inc.

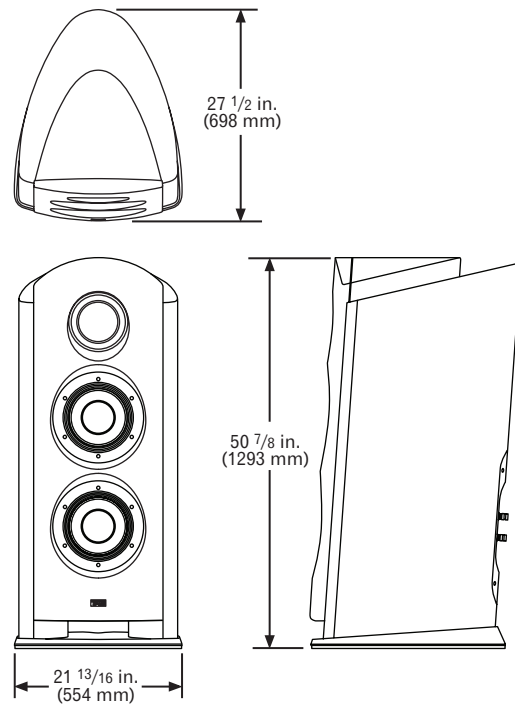

Figure 12. Overall dimensions of the TAD Reference One loudspeaker.

Selecting fine audio equipment such as the unit you've just purchased is only the start of your musical enjoyment. Now it's time to consider how you can maximize the fun and excitement your equipment offers. This manufacturer and the Electronic Industries Association's Consumer Electronics Group want you to get the most out of your equipment by playing it at a safe level. One that lets the sound come through loud and clear without annoying blaring or distortion and, most importantly, without affecting your sensitive hearing.



Sound can be deceiving. Over time your hearing comfort level adapts to higher volumes of sound. So what sounds *normal* can actually be loud and harmful to your hearing. Guard against this by setting your equipment at a safe level *BEFORE* your hearing adapts.

To establish a safe level:

- Start your volume control at a low setting.
- Slowly increase the sound until you can hear it comfortably and clearly, and without distortion.

Once you have found a comfortable sound level:

- Set the volume control and leave it there.

We Want You Listening For A Lifetime...

Taking a minute to do this now will help to prevent hearing damage or loss in the future. After all, we want you listening for a lifetime.

Used wisely, your new sound equipment will provide a lifetime of fun and enjoyment. Since hearing damage from loud noise is often undetectable until it is too late, this manufacturer and the Electronic Industries Association's Consumer Electronics Group recommend you avoid prolonged exposure to excessive noise. This list of sound levels is included for your protection:



dB

Level Example*

30	Quiet library, or soft whispers
40	Living room, refrigerator, or bedroom away from traffic
50	Light traffic, normal conversation, or quiet office
60	Air conditioner at 20 feet, or sewing machine
70	Vacuum cleaner, hair dryer, or noisy restaurant
80	Average city traffic, garbage disposals, or alarm clock at two feet

The following noises can be dangerous under constant exposure:

90	Subway, motorcycle, truck traffic, or lawn mower
100	Garbage truck, chain saw, or pneumatic drill
120	Rock band concert in front of speakers, or thunderclap
140	Gunshot blast, or jet plane
180	Rocket launching pad

**Information courtesy of the Deafness Research Foundation.*

TAD

TECHNICAL AUDIO DEVICES LABORATORIES, INC.

Published by Pioneer Corporation.
Copyright © 2009 TECHNICAL AUDIO DEVICES LABORATORIES, INC.
All rights reserved.

TECHNICAL AUDIO DEVICES LABORATORIES, INC.

4-15-3 Nishi-Shinjuku Shinjuku-ku, Tokyo 160-0023, Japan
<http://tad-labs.com>