

### SCOTT AIR-PAK 75i Industrial Pressure-Demand Self Contained Breathing Apparatus (SCBA) Models 2.2 / 4.5

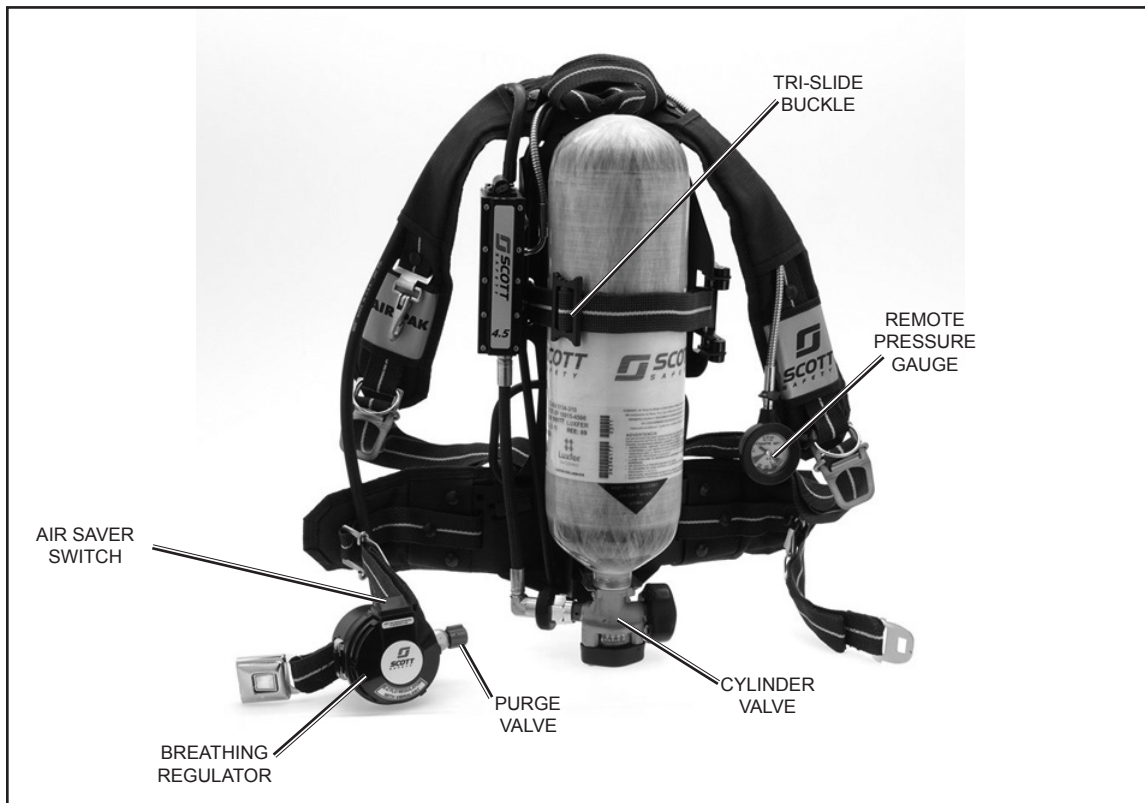

TYPICAL AIR-PAK 75i SCBA

Typical configuration of SCOTT AIR-PAK 75i SCBA's shown.  
Appearance of respirators may vary depending on optional and accessory equipment.

## WARNING

**IMPROPER USE OF THIS RESPIRATOR MAY RESULT IN PERSONAL INJURY OR DEATH. IMPROPER USE INCLUDES, BUT IS NOT LIMITED TO, USE WITHOUT ADEQUATE TRAINING, DISREGARD OF THE WARNINGS AND INSTRUCTIONS CONTAINED HEREIN, AND FAILURE TO INSPECT AND MAINTAIN THIS RESPIRATOR. READ AND UNDERSTAND ALL INSTRUCTIONS BEFORE ATTEMPTING TO OPERATE OR SERVICE THIS EQUIPMENT.**

**THIS RESPIRATOR IS INTENDED TO BE USED ONLY IN CONJUNCTION WITH AN ORGANIZED RESPIRATORY PROTECTION PROGRAM WHICH COMPLIES WITH THE REQUIREMENTS OF "PRACTICES FOR RESPIRATORY PROTECTION," Z88.2 AVAILABLE FROM AMERICAN NATIONAL STANDARDS INSTITUTE INC., 1430 BROADWAY, NEW YORK, N.Y., 10018, OR THE REQUIREMENTS OF OSHA SAFETY AND HEALTH STANDARD 29 CFR 1910 PARAGRAPH 134 AVAILABLE FROM THE U. S. DEPARTMENT OF LABOR, OCCUPATIONAL SAFETY AND HEALTH ADMINISTRATION, OR OTHER PERTINENT NATIONALLY RECOGNIZED STANDARDS, SUCH AS THOSE PROMULGATED BY THE U. S. COAST GUARD OR THE DEPARTMENT OF DEFENSE.**

# SCOTT AIR-PAK 75i

## Industrial Pressure-Demand

### Self Contained Breathing Apparatus (SCBA)

#### Models 2.2 / 4.5

#### DESCRIPTION

The SCOTT AIR-PAK 75i self contained breathing apparatus (SCBA) is intended to provide respiratory protection to an individual when entering into, working in, and exiting from an objectionable, oxygen deficient, and/or unbreathable (toxic) atmosphere.

TRAINING IS REQUIRED BEFORE USE. The SCOTT AIR-PAK 75i SCBA respirator is to be used **only** by persons trained in the use of the respirator and **only** in conjunction with an organized respiratory protection program. The SCBA must be used and maintained properly. This respirator is not to be used under water, for interior structural fire fighting or for any other purpose not authorized by the organized respiratory protection program that applies specifically to the user.

At a minimum, the SCOTT AIR-PAK 75i SCBA consists of the following:

- a cylinder and valve assembly to store a supply of breathing air under pressure,
- a backframe and harness assembly to support the cylinder and valve assembly and pressure reducer on the body,
- a backframe mounted pressure reducer with a remote pressure gauge,
- a facepiece mounted pressure demand breathing regulator with an air saver switch,
- a SCOTT full facepiece and a head harness to secure the facepiece to the face.

All SCOTT AIR-PAK 75i SCBA's described in this instruction are equipped with one end of service time indicator, a remote pressure gauge mounted on the shoulder strap, and an air saver switch located on the breathing regulator. All model respirators described by these instructions are equipped with shoulder straps, waist straps and head harnesses are made of Kevlar<sup>1</sup>.

The full facepiece is available in a variety of models and sizes and must be properly fitted to the user before use. The facepiece design incorporates a nose cup, two inhalation valves and dual voicemitter assemblies. The facepiece detaches from the breathing regulator to allow for use of the best fitting and most comfortable size facepiece for each user. Fit testing per OSHA Standard 29 CFR Part 1910 or ANSI Standard Z88.2 requires testing in the negative pressure mode using equipment such as a Portacount Plus<sup>2</sup> Respirator Fit Tester. For this, SCOTT facepieces require use of SCOTT Fit Test Adapter P/N 804057-01 or equivalent and appropriate negative pressure testing equipment. Mask Seal Kit P/N 805655-01 may also be required to attain a proper fit.

#### WARNING

DO NOT OPERATE THIS EQUIPMENT WHILE UNDER THE INFLUENCE OF DRUGS, ALCOHOL, OR ANY MEDICATIONS OR SUBSTANCES WHICH MAY AFFECT VISION, DEXTERITY, OR JUDGMENT. USERS OF THIS EQUIPMENT MUST BE IN GOOD PHYSICAL AND MENTAL HEALTH IN ORDER TO OPERATE SAFELY. DO NOT USE THIS EQUIPMENT WHEN FATIGUE PREVENTS SAFE OPERATION. STAY ALERT WHEN OPERATING THIS EQUIPMENT. INATTENTION OR CARELESSNESS WHILE OPERATING THIS EQUIPMENT MAY RESULT IN SERIOUS INJURY OR DEATH.

#### WARNING

THIS RESPIRATOR, IS INTENDED TO PROTECT THE USER ONLY FROM THE EFFECTS OF AN OXYGEN DEFICIENT ATMOSPHERE AND/OR ATMOSPHERES CONTAINING TOXIC OR HAZARDOUS SUBSTANCES BY PROVIDING A SUPPLY OF RESPIRABLE BREATHING AIR TO A FACEPIECE SEALED TO THE USER'S FACE.

WHEN PROPERLY USED, THIS RESPIRATOR PROVIDES PROTECTION FROM AIRBORNE TOXIC OR HAZARDOUS SUBSTANCES ONLY TO THE EYES AND RESPIRATORY SYSTEM. IMPROPER USE OF THIS RESPIRATOR MAY RESULT IN SERIOUS INJURY OR DEATH.

#### WARNING

RESPIRATORS SHALL NOT BE WORN WHEN CONDITIONS PREVENT A GOOD FACE TO FACEPIECE SEAL OR A GOOD SEAL AROUND THE NOSE CUP. SUCH CONDITIONS MAY INCLUDE, BUT ARE NOT LIMITED TO, GROWTH OF BEARDS, SIDEBURNS, A SKULL CAP THAT PROJECTS UNDER THE FACEPIECE, OR TEMPLE PIECES ON GLASSES. ALSO, THE ABSENCE OF ONE OR BOTH DENTURES CAN SERIOUSLY EFFECT THE FIT OF THE FACEPIECE. USE OF THE RESPIRATOR WITHOUT A GOOD FACE TO FACEPIECE SEAL OR A GOOD SEAL AROUND THE NOSE CUP SEAL MAY REDUCE THE DURATION OF USE AND/OR EXPOSE THE USER TO THE ATMOSPHERE THE RESPIRATOR IS INTENDED TO PROTECT AGAINST RESULTING IN SERIOUS INJURY OR DEATH.

<sup>1</sup>Kevlar is a registered trademark of E.I. du Pont de Nemours, Inc.

<sup>2</sup>Portacount Plus is a registered trademark of TSI Incorporated

The removable pressure-demand breathing regulator mounts directly to the facepiece. The air saver/donning switch on the breathing regulator prevents the rapid loss of the air supply if the cylinder valve is open and if the facepiece is removed from the face or the regulator is removed from the facepiece. The red purge knob on the regulator allows air to flow into the facepiece in an emergency as well as to release residual air from the respirator after the cylinder valve is turned off.

All models of the AIR-PAK 75i SCBA respirator are equipped with the VIBRALERT alarm in the facepiece mounted regulator. The VIBRALERT alarm serves two functions: as an end of service time indicator, and to alert the user of a malfunction in the dual path pressure reducer. In normal operation, the VIBRALERT alarm vibrates the breathing regulator and facepiece to warn the user by both sound and feel that approximately 25% of full cylinder pressure remains. In addition, the VIBRALERT alarm will be activated to warn the user if there is a malfunction in the primary path of the dual path pressure reducer. Air is normally supplied through the primary air path of the pressure reducer. If the primary air path of the pressure reducer becomes blocked or should fail closed, the secondary air path will automatically begin supplying air to the breathing regulator and the VIBRALERT alarm will be actuated to warn the user of the malfunction.

An optional independent end of service time indicator alarm is the HEADS-UP DISPLAY attached to the facepiece mounted regulator. The HEADS-UP DISPLAY is standard on respirators required to have two independent redundant alarms. The HEADS-UP DISPLAY provides a visual monitor of the air supply with four lights that appear just below the facepiece field of vision. A separate low battery light warns the user that the battery must be changed. The HEADS-UP DISPLAY lights indicate the cylinder air supply is full to three-quarters with constant green lights, one-half cylinder with a slowly flashing yellow light, and warns the user that approximately one quarter or 25% of full cylinder pressure remains with a rapidly flashing red light. The HEADS-UP DISPLAY detects cylinder pressure directly and is totally independent of the VIBRALERT. See the HEADS-UP DISPLAY OPERATION section and the BATTERY REPLACEMENT section of this instruction for complete details.

## **EXPORT AND IMPORT**

The international transport of this equipment and portions thereof is regulated under United States export regulations and may be regulated by the import regulations of other countries.

If you have any questions or concerns regarding these regulations, contact SCOTT at 1-800-247-7257 (or 704-291-8300 outside the continental United States).

## **WARNING**

**THE RESPIRATOR USER MUST IMMEDIATELY LEAVE THE AREA REQUIRING RESPIRATORY PROTECTION WHEN THE END OF SERVICE INDICATOR ALARM ACTUATES. ACTUATION OF ANY END OF SERVICE INDICATOR ALARM WARNS THAT APPROXIMATELY 25% OF FULL PRESSURE REMAINS IN THE AIR SUPPLY CYLINDER (THAT IS, APPROXIMATELY 3/4 OF THE TOTAL AIR SUPPLY HAS BEEN USED) OR THAT THERE IS A MALFUNCTION IN THE RESPIRATOR. A DELAY IN LEAVING THE AREA AFTER ALARM ACTUATION MAY RESULT IN INJURY OR DEATH.**

## CHOOSING THE APPROPRIATE EQUIPMENT

Respirators reduce but do not eliminate all exposure to the hazardous atmosphere. Some facepiece/respirator combinations are more effective than others at reducing exposure depending on the nature and the concentration of the contaminant in the hazardous atmosphere. When choosing a respirator and facepiece, the respiratory protection program under which this respirator is to be used must determine the appropriate level of protection that the facepiece/respirator is expected to provide.

**Use of inappropriate RESPIRATOR equipment for the work environment may result in exposure to the hazardous atmosphere which may cause serious injury or death.**

The respiratory protection program must also take into consideration the levels of exposure which may be hazardous irrespective of respiratory protection (e.g.: contaminants which are toxic through exposure to unprotected skin). Additional protective equipment such as apparel may be required. However, any additional protective equipment must not interfere with access to or operation of the respirator.

When properly donned and operated, the SCOTT ISCBA respirator provides limited protection from airborne contaminants to only the respiratory system and part of the face of the user. The using agency must provide the appropriate protective clothing for use with the ISCBA respirator and must insure that protective clothing does not interfere with the operation of the ISCBA respirator.

NIOSH approval is granted to respiratory protection equipment made up of specific combinations of parts or assemblies that have been successfully tested to the performance standards established by the approval agencies.

To maintain NIOSH approval, an AV-3000 facepiece equipped with a SureSeal face seal P/N 31001738 (Small), P/N 31001739 (Medium), or P/N 31001740 (Large) must be used **only** with Grey Nose Cup P/N 31001043 (Small), P/N 31001044 (Medium), or P/N 31001045 (Large).

If you are using an AV-3000 facepiece equipped with a SureSeal face seal and do not have a Grey Nose Cup, contact SCOTT or your authorized SCOTT distributor. Failure to comply with this requirement will void the approvals for your respirator. Use of a non-approved configuration in a hazardous atmosphere may result in serious injury or death.

### WARNING

THE RESPIRATORY PROTECTION PROGRAM UNDER WHICH THIS EQUIPMENT IS TO BE USED MUST DETERMINE THE APPROPRIATE LEVEL OF PROTECTION THAT THE RESPIRATOR IS EXPECTED TO PROVIDE. USE OF INAPPROPRIATE RESPIRATOR EQUIPMENT FOR THE WORK ENVIRONMENT MAY RESULT IN EXPOSURE TO THE HAZARDOUS ATMOSPHERE WHICH MAY CAUSE SERIOUS INJURY OR DEATH.

### WARNING

THIS RESPIRATOR PROVIDES PROTECTION ONLY TO THE USER'S RESPIRATORY SYSTEM AND TO PART OF THE FACE. IF THE HAZARDOUS ATMOSPHERE CONTAINS TOXINS OR CONTAMINANTS WHICH MAY POISON THROUGH THE SKIN, ADDITIONAL PROTECTIVE EQUIPMENT MAY BE REQUIRED. FAILURE TO PROVIDE ADEQUATE PROTECTIVE EQUIPMENT FOR THE HAZARDS IN THE WORKPLACE MAY RESULT IN SERIOUS INJURY OR DEATH.

### WARNING

TO MAINTAIN NIOSH APPROVAL, AN AV-3000 FACEPIECE EQUIPPED WITH A SURESEAL FACE SEAL P/N 31001738 (SMALL), P/N 31001739 (MEDIUM), OR P/N 31001740 (LARGE) MUST BE USED ONLY WITH GREY NOSE CUP P/N 31001043 (SMALL), P/N 31001044 (MEDIUM), OR P/N 31001045 (LARGE). USE OF A NON-APPROVED CONFIGURATION IN A HAZARDOUS ATMOSPHERE MAY RESULT IN SERIOUS INJURY OR DEATH.

## SERVICE LIFE

Each configuration of self-contained breathing apparatus (SCBA) certified by NIOSH is assigned a "service life" classification for a duration time of each size of air supply cylinder (30 minute, 45 minute, etc.). The service life duration time is determined by NIOSH using a breathing machine designed to simulate an average adult user performing work at a "moderate work rate."

Do not expect to obtain the NIOSH rated service life duration time from this respirator on each use. The work being performed may be more or less strenuous than that used in the NIOSH test. Where work is more strenuous, the duration may be less than one half the NIOSH rated service life, and the time remaining after the end of service indicator alarm actuates may be similarly reduced. The end of service indicator alarm actuates when approximately 25% of full cylinder pressure remains in the cylinder and valve assembly. The alarm will continue to operate until the cylinder is nearly depleted.

The duration time of the respirator will depend on such factors as:

1. the degree of physical activity of the user;
2. the physical condition of the user;
3. the degree to which the user's breathing is affected by emotional factors;
4. the degree of training or experience which the user has with this or similar equipment;
5. whether or not the cylinder is fully charged at the start of the work period;
6. the possible presence in the compressed air of carbon dioxide concentrations greater than .04% normally found in atmospheric air;
7. the atmospheric pressure; for example, if used in a pressurized tunnel or caisson at 2 atmospheres (15 psi gauge or approximately 30 psi absolute) the duration will be one-half as long as when used at 1 atmosphere; and at 3 atmospheres will be one-third as long;
8. loose or improperly fitting facepiece;
9. the condition of the respirator.

## WARNING

**THE USER OF THIS RESPIRATOR MUST RECEIVE TRAINING IN THE OPERATION OF THE RESPIRATOR INCLUDING THE OPERATION OF ALL OPTIONS AND/OR ACCESSORIES INCORPORATED IN THE RESPIRATOR. SEE WARNING AT THE BEGINNING OF PAGE TWO OF THIS INSTRUCTION.**

## WARNING

**ONLY THOSE OPTIONS AND/OR ACCESSORIES AUTHORIZED BY SCOTT AND APPROVED BY NIOSH MAY BE INSTALLED IN THIS RESPIRATOR. THE USE OF UNAUTHORIZED AND/OR UNAPPROVED OPTIONS OR ACCESSORIES COULD CAUSE PARTIAL OR COMPLETE FAILURE OF THE RESPIRATOR WHICH MAY RESULT IN INJURY OR DEATH.**

## WARNING

**RESPIRATORS SHALL NOT BE WORN WHEN CONDITIONS PREVENT A GOOD FACE TO FACEPIECE SEAL OR A GOOD SEAL AROUND THE NOSE CUP. SUCH CONDITIONS MAY INCLUDE, BUT ARE NOT LIMITED TO, GROWTH OF BEARDS, SIDEBURNS, A SKULL CAP THAT PROJECTS UNDER THE FACEPIECE, OR TEMPLE PIECES ON GLASSES. ALSO, THE ABSENCE OF ONE OR BOTH DENTURES CAN SERIOUSLY AFFECT THE FIT OF THE FACEPIECE. USE OF THE RESPIRATOR WITHOUT A GOOD FACE TO FACEPIECE SEAL OR A GOOD SEAL AROUND THE NOSE CUP SEAL MAY REDUCE THE DURATION OF USE AND/OR EXPOSE THE USER TO THE ATMOSPHERE THE RESPIRATOR IS INTENDED TO PROTECT AGAINST RESULTING IN SERIOUS INJURY OR DEATH.**

## SPECIFIC MODEL DESCRIPTIONS

The SCOTT AIR-PAK **75i** SCBA is available as:

- Model 2.2 SCBA (2216 psig operating pressure).
- Model 4.5 SCBA (4500 psig operating pressure).

Each model can be identified by a large yellow label with black printing on the pressure reducer with the word SCOTT printed vertically and the model number (2.2 or 4.5) printed at the bottom. In addition, the remote pressure gauge mounted on the shoulder harness is imprinted with the operating pressure on the face of the gauge. The AIR-PAK **75i** SCBA models are equipped with an aluminum backframe.

All of the SCOTT respirator models are certified by the National Institute of Occupational Safety and Health (NIOSH) as pressure-demand self-contained breathing apparatus. See APPROVAL AND CERTIFICATIONS section of this instruction for additional information. Also see the complete NIOSH Approval Label, SCOTT document P/N 89347-01, included with this instruction.

### SCOTT MODEL 2.2 SCBA

- Certified by NIOSH under approval number TC-13F-80 as a 30-minute rated respirator.
- Use only with cylinder and valve assemblies with a full rated service pressure of 2216 psig

### SCOTT MODEL 4.5 SCBA

- Use only with cylinder and valve assemblies with a full rated service pressure of 4500 psig
- Certified by NIOSH (depending on the cylinder and valve assembly installed) as a
  - 30-minute rated SCBA under approval number TC-13F-76
  - 45-minute rated SCBA under approval number TC-13F-212
  - One hour rated SCBA under approval number TC-13-96

The time duration ratings are approval agency classifications and are not intended to indicate the actual duration a user may achieve. Please see the SERVICE LIFE section of this instruction for additional information.

## APPROVALS AND CERTIFICATIONS

All models of the SCOTT AIR-PAK **75i** SCBA described in these instructions conform to the requirements of Title 42 Part 84 of the Code of Federal Regulations and are certified by the National Institute of Occupational Safety and Health (NIOSH). Each respirator configuration is approved under the appropriate approval number for the air pressure and time duration. See the complete NIOSH approval label, SCOTT document P/N 89347-01, included with these instructions. Also see the CAUTIONS AND LIMITATIONS SECTION and the SPECIFIC LIMITATIONS section of these instructions for the cautions and limitations which apply to NIOSH certified respirators of this type.

The SCOTT AIR-PAK **75i** respirator is a modular design composed of replaceable subassemblies and may include certain SCOTT accessories. Each major subassembly and accessory is labeled with its SCOTT part number. In order to maintain the NIOSH approved status of the respirator, use only those subassemblies and/or accessories listed as applicable to a particular NIOSH approval number.

All models of the SCOTT AIR-PAK **75i** SCBA are certified by NIOSH for use in ambient temperatures down to -25° F (-32° C). See LOW TEMPERATURE OPERATION section of this instruction. To maintain NIOSH certification, AIR-PAK **75i** SCBA cylinders must be refilled with compressed air which meets the requirements for Grade D or higher compressed air as specified in the Compressed Gas Association publication CGA G-7.1 entitled *Commodity Specification for Air*, available from the Compressed Gas Association, Inc., 1725 Jefferson Davis Hwy., Suite 1004, Arlington, VA 22202. In addition to meeting these requirements, the air must be dry to a dew point of -65° F (-54° C) or less. See SCOTT *Specialist Level Maintenance Modules* available upon request from SCOTT for additional information on refilling SCOTT SCBA cylinders.

## WARNING

THIS RESPIRATOR PROVIDES PROTECTION ONLY TO THE USER'S RESPIRATORY SYSTEM AND TO PART OF THE FACE. IF THE HAZARDOUS ATMOSPHERE CONTAINS TOXINS OR CONTAMINANTS WHICH MAY POISON THROUGH THE SKIN, ADDITIONAL PROTECTIVE EQUIPMENT MAY BE REQUIRED. FAILURE TO PROVIDE ADEQUATE PROTECTIVE EQUIPMENT FOR THE HAZARDS IN THE WORKPLACE MAY RESULT IN SERIOUS INJURY OR DEATH.

## HEADS-UP DISPLAY OPERATION

The optional HEADS-UP DISPLAY provides a visual monitor of the air supply in the cylinder and valve assembly. The display is fitted to the facepiece mounted regulator and appears across the bottom of the user's field of view through the facepiece. The HEADS-UP DISPLAY consists of four rectangular lights to represent the cylinder pressure at FULL, THREE-QUARTERS, ONE-HALF, and ONE-QUARTER. A fifth round red light indicates LOW BATTERY. The HEADS-UP DISPLAY operates as follows:

1. When respirator use begins, the HEADS-UP DISPLAY will initialize and illuminate all five lights for twenty (20) seconds. Operation of all five lights must be verified every time respirator use is begun and with every REGULAR OPERATIONAL INSPECTION.

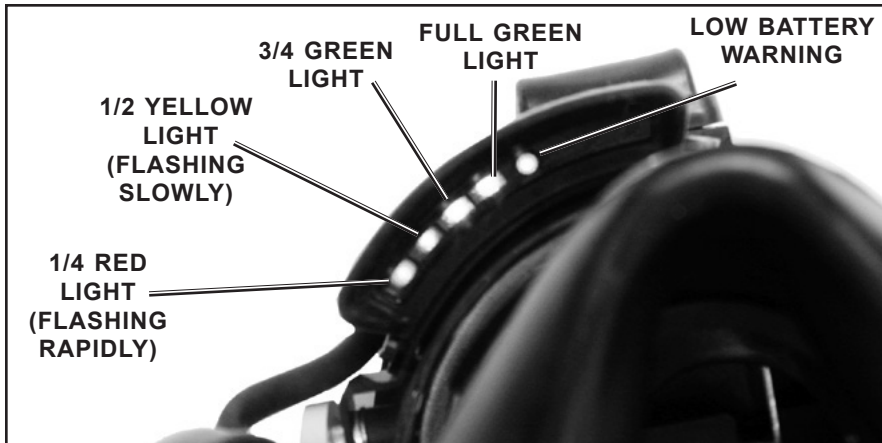

**FIGURE 1  
HEADS-UP DISPLAY**

2. After initialization, the rectangular indicator lights will show the level of the air supply in the cylinder as follows:
  - a) FULL cylinder is indicated by the two green lights glowing near the center of the display.
  - b) THREE-QUARTERS cylinder is indicated by a single green light glowing.
  - c) ONE-HALF cylinder is indicated by the yellow light flashing slowly at once a second.
  - d) ONE-QUARTER cylinder end of service time indicator is indicated by the red light at the far left flashing rapidly at ten times a second. WHEN THIS WARNING LIGHT IS FLASHING RAPIDLY, THE USER MUST LEAVE THE HAZARDOUS ATMOSPHERE IMMEDIATELY.
3. When the battery requires changing, the round LOW BATTERY indicator at the right of the display will light for twenty (20) seconds and then begin to flash slowly at once a second. When the LOW BATTERY indicator is actuated, the battery still has sufficient life to operate the HEADS-UP DISPLAY longer than the longest duration cylinder installed on the respirator. However, the battery must be changed immediately upon termination of use of the respirator, or before reentry into a hazardous atmosphere. See the BATTERY REPLACEMENT section of this instruction.

### WARNING

THE RESPIRATOR USER MUST IMMEDIATELY LEAVE THE AREA REQUIRING RESPIRATORY PROTECTION WHEN AN END OF SERVICE INDICATOR ALARM ACTUATES. ACTUATION OF ANY END OF SERVICE INDICATOR ALARM WARNS THAT APPROXIMATELY 25% OF FULL PRESSURE REMAINS IN THE AIR SUPPLY CYLINDER (THAT IS, APPROXIMATELY 3/4 OF THE TOTAL AIR SUPPLY HAS BEEN USED) OR THAT THERE IS A MALFUNCTION IN THE RESPIRATOR. A DELAY IN LEAVING THE AREA AFTER ALARM ACTUATION MAY RESULT IN SERIOUS INJURY OR DEATH.

### HEADS-UP DISPLAY QUICK GUIDE

INDICATOR LIGHTS	WHAT THEY MEAN	WHAT YOU SHOULD DO
TWO LIGHTS GLOWING	FULL CYLINDER	CONTINUE USING RESPIRATOR
ONE LIGHT GLOWING	3/4 CYLINDER	
ONE LIGHT FLASHING SLOWLY	1/2 CYLINDER	
ONE LIGHT FLASHING RAPIDLY	1/4 CYLINDER	LEAVE HAZARDOUS AREA IMMEDIATELY

## FACEPIECE FITTING AND FIT TESTING

A respirator Quantitative Fit Test must be performed to ensure the correct respirator facepiece size has been selected and assigned to the user. It is the responsibility of the Respiratory Protection Program Manager or Safety Coordinator to assist the user in selecting the correct respirator size relative to the user's facial features and dimensions. Fit Testing must be performed with any approved SCOTT accessories that will be used with the respirator installed, such as a communications device installed on the facepiece.

Respirator fit tests are explained fully in the American National Standard Practices for Respiratory Protection, ANSI Z88.10-2001 which is published by the American National Standards Institute (ANSI), 11 West 42nd Street, New York, New York, 10036, and in the Occupational Safety and Health Standards, OSHA 29 CFR 1910.134 Appendix A, which is published by the Occupational Safety and Health Administration (OSHA), 200 Constitution Avenue, NW, Washington DC, 20210.

Quantitative Fit Testing per OSHA Standard 29 CFR Part 1910.134 Appendix A, or ANSI Standard Z88.10-2001 requires testing in the negative pressure mode using equipment such as a Portacount<sup>1</sup> Respirator Fit Tester. For Quantitative Fit Testing, SCOTT facepieces require use of the appropriate negative pressure testing equipment such as the Portacount Respirator Fit Tester along with the following:

- SCOTT 40mm facepiece Adapter, P/N 200423-01,
- a new SCOTT P100 Cartridge, P/N 052683,
- SCOTT Probed Fit Test Adapter P/N 805628-01 or equivalent probed facepieces and the full range of sizes and styles
- Mask Seal Kit, P/N 805655-01
- the appropriate SCOTT communication device and mounting bracket properly installed on the facepiece, if such an accessory will be used with the respirator.
- any other optional hood, eyeglass, or other accessory that will be used with the respirator.

The size and style facepiece must be selected based on the user's measured face size. For initial fitting, carefully don the facepiece and conduct a **NEGATIVE PRESSURE LEAK TEST** according to the instructions provided with the 40mm Adapter. Refer to the **DONNING PROCEDURE** section of this instruction for the procedure. Follow the **DONNING PROCEDURE CAREFULLY**. If the selected facepiece does not pass the **NEGATIVE PRESSURE LEAK TEST** or does not fit securely without movement in the chin or chin cup area or the user experiences discomfort in the chin or throat, try the next nearest size, larger or smaller. After passing the **NEGATIVE PRESSURE LEAK TEST**, the facepiece size selected must be verified by successfully passing a respirator Quantitative Fit Test.

When fit testing for Open-Circuit, Pressure Demand Self-Contained Breathing Apparatus and/or Type C Pressure-Demand Supplied Air Respirator mode of operation (minimum Fit Factor equal to or greater than 500 minimum) appropriate negative pressure testing equipment must be used. You should use a P100 Filter, SCOTT P/N 052683 and the SCOTT P/N 805628-01 Fit Test Adapter.

When using a Portacount Respirator Fit Tester for Quantitative Fit Testing, TSI recommends that the level of particles in the ambient air must be between 5000 and 30000 particles/cm<sup>3</sup>. Refer to the Portacount Respirator Fit Tester user instructions for details including available Particle Generators to use with the Portacount Respirator Fit Tester if you have difficulty achieving the minimum level of ambient particle count required.

Test subjects must be in good health at the time of the fit testing. Smoking or eating less than 30 minutes prior to the test is prohibited. Any and all conditions that might interfere with a good face to facepiece seal must be addressed and corrected before performing the fit testing. Refer to the list of conditions in the **DONNING PROCEDURES** section of this instruction.

### WARNING

**THE USER MUST BE PROPERLY FITTED USING A RESPIRATOR QUANTITATIVE FIT TEST BEFORE USE AND FOLLOW ALL WARNINGS AND SPECIAL OR CRITICAL USER'S INSTRUCTIONS SPECIFIED DURING USE. FAILURE TO DO SO MAY RESULT IN SERIOUS INJURY OR DEATH.**

### WARNING

**FIT TESTING IN ACCORDANCE WITH OSHA STANDARD 29 CFR PART 1910 IS REQUIRED AS PART OF THE REQUIRED TRAINING BEFORE USE OF THIS RESPIRATOR. FAILURE TO PROPERLY FIT AND TRAIN THE USER IN USE OF THE FACEPIECE AND RESPIRATOR MAY RESULT IN EXPOSURE TO THE HAZARDOUS ATMOSPHERE WHICH COULD LEAD TO SERIOUS INJURY OR DEATH.**

### WARNING

**RESPIRATORS SHALL NOT BE WORN WHEN CONDITIONS PREVENT A GOOD FACE SEAL. SUCH CONDITIONS MAY INCLUDE, BUT ARE NOT LIMITED TO, GROWTH OF BEARDS, SIDEBURNS, FACIAL HAIR OR LOW HAIRLINE THAT CROSSES OR INTERFERES WITH THE SEALING SURFACE, THICK OR PROTRUDING HAIRSTYLES SUCH AS PONY TAILS OR BUNS THAT INTERFERE WITH THE SMOOTH AND CLOSE FIT OF THE HEAD HARNESS TO THE HEAD, A SKULL CAP THAT PROJECTS UNDER THE FACEPIECE, TEMPLE PIECES ON CORRECTIVE EYE GLASSES, EXCESSIVE USE OF COSMETICS INCLUDING MOISTURIZERS, MAKE-UP, OR AFTER SHAVE, OR ANYTHING ELSE WHICH INTERFERES WITH THE FACE TO FACEPIECE SEAL. ALSO, THE ABSENCE OF ONE OR BOTH DENTURES CAN SERIOUSLY AFFECT THE FIT OF A FACEPIECE. USE OF AN IMPROPERLY FITTED FACEPIECE MAY LEAD TO EXPOSURE TO THE HAZARDOUS ATMOSPHERE WHICH COULD RESULT IN SERIOUS INJURY OR DEATH.**



To verify the fit factor of the respirator, testing must incorporate an exercise regimen of normal daily activities. SCOTT requires the following set of fit test exercises, which are based on OSHA Standard 29 CFR Part 1910.134 Appendix A, and ANSI Z88.10-2001 with modifications.

Exercises are to be performed each for 60 seconds (except as noted) in a standing position during the test:

- Normal Breathing
- Deep breathing
- Turning head side to side
- Moving head up and down (look up/look down)
- Talking (read the Rainbow Passage)
- Grimace (15 seconds)
- Bending Over (touch toes) / Reach up (toward the ceiling)
- Normal Breathing (repeat)

Fit test exercises must be performed carefully as if the respirator was being used in a hazardous atmosphere. DO NOT bump the facepiece, filter, or adapter into the body through exaggerated motions. DO NOT talk except when directed to by the test administrator.

SCOTT requires that users of this respirator with an approved SCOTT facepiece, must achieve a Fit Factor of at least 500 for Type C Pressure-Demand Supplied Air Respirator mode of operation for use with their assigned facepiece style and size using the fit test procedures and exercise regimen stated above. If a Fit Factor of at least 500 cannot be achieved with any facepiece size or style, the user MUST NOT use this respirator.

If the respirator user passes a NEGATIVE PRESSURE LEAK TEST but DOES NOT pass a respirator Quantitative Fit Test, try the next nearest size, larger or smaller and repeat the NEGATIVE PRESSURE LEAK TEST and the Quantitative Fit Test. If leakage is still detected, either per these user instructions or the OSHA fit testing process, the use of Mask Seal Kit P/N 805655-01 may be required to attain a proper fit. Refer to the INSTALLATION AND USE INSTRUCTIONS, SCOTT P/N 89462-01, included with the Mask Seal Kit. After installing the Mask Seal Kit, repeat the fit testing process to confirm a proper fit.

Once the proper size is selected and assigned to the user following successful Portacount Respirator Fit Tester testing to achieve minimum Fit Factors required, the respirator user must perform and pass a NEGATIVE PRESSURE LEAK TEST as described in these instructions every time the facepiece is donned to ensure proper fit before using the respirator in a hazardous atmosphere.

During NEGATIVE PRESSURE LEAK TESTING, any facepiece leakage that is detected from other than the face to facepiece seal may indicate damaged or defective equipment. Remove the defective equipment from service and tag for repair by authorized personnel. Repeat the testing with equipment known to be operating properly.

**IF A SATISFACTORY NEGATIVE PRESSURE LEAK TEST CANNOT BE PERFORMED, DO NOT USE THE RESPIRATOR OR ENTER THE HAZARDOUS ATMOSPHERE.**

The facepiece alone does not provide any protection against a hazardous atmosphere without the use of the complete respirator.

A respirator Quantitative Fit Test must be routinely carried out as outlined above for each user of this respirator to determine or confirm the amount of protection that the respirator provides.

Periodically repeating the fit testing is required to identify any physical changes of the user (such as those listed in the DONNING PROCEDURES) which could effect the fit of the facepiece.

## REGULAR OPERATIONAL INSPECTION

The following procedure shall be used when you first receive the respirator and for daily or periodic inspection of the respirator. Respirators in regular use must be inspected at the start of each use period and during cleaning after each use. Respirators maintained for emergency use must be inspected as frequently as required to assure the respirator will function properly when required. The US Labor Department (OSHA), pursuant to 29 CFR 1910.134, requires at least monthly inspection of respirators maintained for emergency use. NIOSH recommends an inspection for cylinder pressure at least weekly. The condition of storage at your location or the regulations which apply to your respiratory protection program may require more frequent periodic inspections.

If the respirator is equipped with a PASS device distress alarm, the following procedures must be modified to include inspection of the PASS device. Details of the REGULAR OPERATIONAL INSPECTION of the PASS device are included in the user instructions for the PASS device. The part number of the required PASS user instructions appears on the label on the battery cover of the PASS device Sensor Module.

IF ANY DISCREPANCY OR MALFUNCTION IS NOTED DURING THE INSPECTION, DO NOT USE THE RESPIRATOR. REMOVE THE RESPIRATOR FROM SERVICE AND TAG IT FOR REPAIR BY AUTHORIZED PERSONNEL.

### INSPECTION OF THE BREATHING AIR CYLINDER

1. Visually inspect breathing air cylinder and valve assembly for physical damage such as dents or gouges in metal or in composite wrapping. Cylinders which show physical damage or exposure to high heat or flame, such as paint turned brown or black, decals charred or missing, pressure gauge lens melted or elastomeric bumper distorted, and cylinders which show evidence of exposure to chemicals such as discoloration, cracks in the cylinder or the composite wrapping, peeling of the outer layers of the composite wrapping and/or bulging of the cylinder wall, shall be removed from service and emptied of compressed air. Publications on compressed gas cylinder inspection procedures are available from Compressed Gas Association Inc., 1725 Jefferson Davis Hwy., Suite 1004, Arlington, VA 22202 (703-412-0900).
2. Check the latest cylinder hydrostatic test date to ensure it is current. The date of manufacture marked on the cylinder is also the date of the first hydrostatic test. All breathing air cylinders used with SCOTT AIR-PAK **75i** SCBA's must be visually inspected regularly and hydrostatically tested at the required intervals by a licensed cylinder re-tester. Intervals for hydrostatic testing are established in the appropriate US Department of Transportation (DOT) specification or applicable DOT exemption, or in the appropriate Transport Canada (TC) Permit of Equivalent Level of Safety. Refer to the current revision of *Safety Precautions for AIR-PAK Cylinders*, SCOTT P/N 89080-01, available on request from SCOTT Safety. Composite fiber over-wrapped cylinders must be tested up to their maximum life which, at the time of the publication of this instruction, is 15 years from the date of manufacture. It is the responsibility of your organized respiratory protection program to arrange for visual inspection and hydrostatic testing of cylinders by a licensed re-tester.
3. Check for damage of the cylinder valve hand wheel and the threads on the cylinder valve outlet.
4. Check the relief valve (burst disc) for damage or dirt.
5. Check the cylinder pressure gauge for "FULL" indication. If cylinder pressure is less than "FULL," replace with a fully charged cylinder.

## WARNING

THE INFORMATION IN THIS INSTRUCTION IS MEANT TO SUPPLEMENT, NOT REPLACE, THE INSTRUCTIONS, TRAINING, SUPERVISION, MAINTENANCE, AND OTHER ELEMENTS OF YOUR ORGANIZED RESPIRATORY PROTECTION PROGRAM. SEE WARNING ON SECOND PAGE OF THIS DOCUMENT. FAILURE TO HEED ANY WARNINGS IN THIS INSTRUCTION MAY RESULT IN SERIOUS INJURY OR DEATH.

## WARNING

FOLLOW THE REGULAR OPERATIONAL INSPECTION PROCEDURE EXACTLY. IF THE END OF SERVICE INDICATOR ALARM DOES NOT ACTUATE AS DESCRIBED IN THIS INSTRUCTION, THE PURGE DOES NOT ACTUATE AS DESCRIBED IN THIS INSTRUCTION OR ANY OTHER OPERATIONAL MALFUNCTION IS NOTED, DO NOT USE THE RESPIRATOR. REMOVE THE RESPIRATOR FROM SERVICE AND TAG IT FOR REPAIR BY AUTHORIZED PERSONNEL. FAILURE TO PROPERLY IDENTIFY MALFUNCTIONS MAY RESULT IN SERIOUS INJURY OR DEATH.

## WARNING

IF THE RESPIRATOR IS EQUIPPED WITH A PASS DEVICE DISTRESS ALARM AND IT FAILS TO FUNCTION IN ACCORDANCE WITH THE INSTRUCTIONS CONCERNING REGULAR OPERATIONAL INSPECTION SUPPLIED WITH THE DISTRESS ALARM, DO NOT USE THE RESPIRATOR. REMOVE IT FROM SERVICE AND TAG FOR REPAIR BY AUTHORIZED PERSONNEL. FAILURE TO PROPERLY IDENTIFY MALFUNCTIONS MAY RESULT IN SERIOUS INJURY OR DEATH.

## WARNING

DAMAGED CYLINDERS MAY SUDDENLY LEAK OR RUPTURE IF LEFT CHARGED WITH COMPRESSED AIR. FAILURE TO INSPECT FOR DAMAGE AND TO EMPTY THE AIR FROM DAMAGED CYLINDERS MAY RESULT IN SERIOUS INJURY OR DEATH.

## **INSPECTION OF THE RESPIRATOR**

If any damage is found in this inspection, remove the respirator from service and tag for repair by authorized personnel.

1. Inspect the complete respirator for worn or damaged components.
  - a) Inspect hoses and rubber parts which exhibit cracking, splitting, or brittleness.
  - b) Inspect harness webbing for cuts, tears, abrasion, fraying, or indication of heat or chemical damage.
  - c) Check all buckles and fasteners for proper operation.
  - d) Check the cylinder retention system for damage and for proper operation.
  - e) Verify that the respirator has been properly cleaned.
2. Remove the breathing regulator from the facepiece by pulling back on the regulator retaining latch and rotating the regulator  $\frac{1}{4}$  turn. Inspect the gasket on the breathing regulator that seals against the facepiece for rips or damage that may break the seal.
3. Inspect the breathing regulator for damaged or missing components.
  - a) Verify that the regulator gasket is not damaged and is in place around the outlet port of the regulator.
  - b) Verify that the purge valve (red knob) is not damaged and turns smoothly one-half turn from stop to stop.

## **FACEPIECE INSPECTION**

Examine the facepiece assembly for damaged or worn components. The facepiece must be complete and in serviceable condition with no worn, loose, or damaged components. Inspect the facepiece as follows:

1. Inspect the facepiece seal and other rubber components for deformation, wear, damage, or cracks.
2. Inspect the lens for cracks, gouges, scratches, or any condition that could impair the operation of the facepiece or the user's vision.
3. Inspect the lens frame or bezel for damage such as cracks or distortion.
4. Check that all lens frame retainers or bezel screws are present and installed correctly.
5. Check that all harness anchors are present and operating properly.
6. Inspect the head harness for correct installation with all straps oriented correctly.
7. Inspect the head harness for damage or worn components.
8. Inspect the voicemitters for dents or damage. Verify that the voicemitters are properly installed and secure in the voicemitter ducts.



**FIGURE 1**  
**Checking Voicemitter Ducts**

9. Inspect the nose cup for cuts or damage. Also look for any signs of damage to the facepiece port side of the nose cup where the regulator attaches.  
Check that the nose cup is properly seated between the flanges of the voicemitter ducts. See FIGURE 1.

## **WARNING**

**RESPIRATORS MUST BE CLEANED AND INSPECTED BEFORE STORAGE FOR REUSE. RESPIRATORS WITH WORN OR DAMAGED COMPONENTS SHALL NOT BE STORED FOR REUSE. REPLACE WORN OR DAMAGED COMPONENTS DURING INSPECTION OR REMOVE THE RESPIRATOR FROM SERVICE AND TAG IT FOR REPAIR BY AUTHORIZED PERSONNEL. USE OF A RESPIRATOR WITH WORN OR DAMAGED COMPONENTS MAY RESULT IN SERIOUS INJURY OR DEATH.**

**REGULAR OPERATIONAL INSPECTION  
CONTINUED ON NEXT PAGE...**

## REGULAR OPERATIONAL INSPECTION CONTINUED...

10. Verify that the facepiece is clean.
11. Adjust the head straps to the full outward position.
12. All SCOTT facepieces used with this respirator may be fitted with a nose cup. Verify that the Nose Cup is properly installed for the model of facepiece being used. A Nose Cup is standard on the SCOTT AV-2000 and AV-3000 full facepieces and optional on the SCOTT-O-VISTA full facepiece.
  - a) SCOTT AV-3000 Facepieces are available with two different styles of nose cup: a BLACK Nose Cup which fits behind the face seal, and a GRAY Nose Cup which fits in front of the face seal. The BLACK Nose cup must be fitted BEHIND the Face Seal as shown in FIGURE 2. The GRAY Nose Cup must be fitted IN FRONT OF the Face Seal as shown in FIGURE 3.

### AV-3000 FACEPIECES ONLY

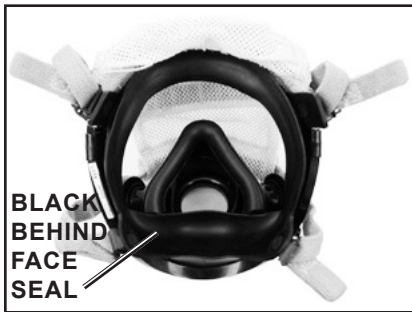

**FIGURE 2**  
**BLACK Nose Cup**  
**BEHIND Face Seal**



**FIGURE 3**  
**GRAY Nose Cup**  
**IN FRONT OF Face Seal**

- b) The AV-2000 Nose Cup always goes BEHIND the face seal REGARDLESS of the color of the nose cup. See FIGURE 4.

### AV-2000 FACEPIECES ONLY



**FIGURE 4**  
**AV-2000 Nose Cup**  
**Always BEHIND the Face Seal**

### CAUTION

IF THE NOSE CUP IS REMOVED FOR INSPECTION, MAKE CERTAIN IT IS REASSEMBLED CORRECTLY FOR THE MODEL FACEPIECE AND STYLE OF NOSE CUP.

### CAUTION

DO NOT USE TOOLS TO OPEN OR CLOSE THE PURGE VALVE. OPEN OR CLOSE BY USING FINGER-PRESSURE ONLY. ROTATION OR THE PURGE VALVE IS LIMITED TO 1/2 TURN. USE OF TOOLS TO OPEN OR CLOSE PURGE VALVE MAY RESULT IN DAMAGE TO THE PURGE VALVE.

5. If the hose to the breathing regulator is equipped with a quick disconnect, inspect both the male and female quick disconnects. Pay special attention to the following:
  - a) Inspect the operation of the locking sleeve on the female quick disconnect. If any damage is noted, remove it from service and tag for repair.
  - b) Inspect the condition of the male quick disconnect for signs of wear. Particularly look for wear on the locking ridge as shown in FIGURE 5. If the coating is worn through and bare metal is showing, do not use the regulator assembly. Remove it from service and tag for replacement.

**FIGURE 5**  
**Inspecting Male Quick Disconnects**



6. Verify that the quick disconnect operates properly. Breathing regulators equipped with a quick disconnect use a Pull-back Sleeve Coupling. See FIGURE 6. To separate, push the plug "D" into the socket while pulling the locking sleeve "E" back toward the guard. The plug "D" will separate. To connect, push the plug "D" into the socket until it engages with a "click."
7. If the regulator is not attached to the facepiece, proceed as follows:

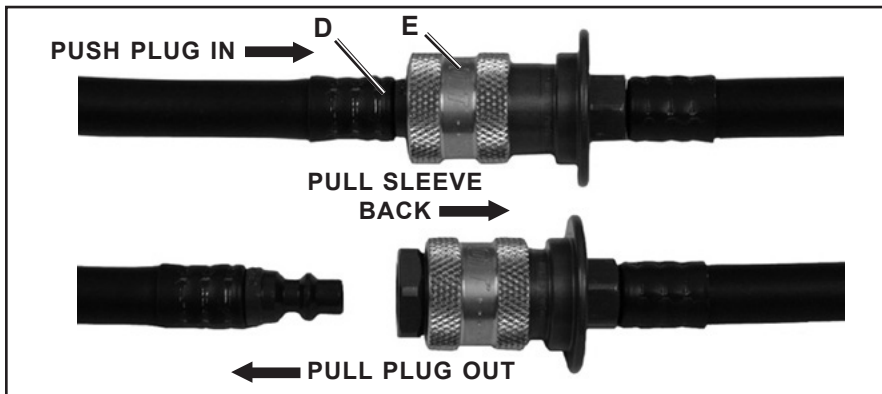

**FIGURE 6**  
**Pull-back Sleeve Quick Disconnect**

- a) Align the two flats of the regulator outlet port with the corresponding flats in the facepiece port (the red purge valve on the regulator will be in the 12 o'clock position). Insert the regulator into the facepiece port.
  - b) Rotate the regulator counterclockwise (as viewed from inside of facepiece) until the red purge valve knob is on the left side of the facepiece. The lock tab on the regulator will lock into the facepiece retainer with a "click." When the lock tab is properly engaged, the regulator will not rotate.
8. If the hose to the breathing regulator is equipped with a quick disconnect, check that the quick disconnect is engaged properly by tugging on the coupling.
  9. Verify that a FULL cylinder is properly installed in the backframe and that the reducer hose coupling is hand tightened to the cylinder valve outlet.

If no damage is found, proceed to the OPERATIONAL TESTING.

### WARNING

IF THE COATING IS WORN THROUGH AND BARE METAL IS SHOWING ON THE MALE QUICK DISCONNECT LOCKING RIDGE, REMOVE THE REGULATOR ASSEMBLY FROM SERVICE AND TAG FOR REPLACEMENT. USE OF A WORN QUICK DISCONNECT MAY RESULT IN A MALFUNCTION LEADING TO A LOSS OF BREATHING AIR WHICH COULD RESULT IN SERIOUS INJURY OR DEATH.

### WARNING

FAILURE TO CHECK ENGAGEMENT OF THE COUPLING AS DESCRIBED MAY LEAD TO HOSE SEPARATION AND LOSS OF BREATHING AIR RESULTING IN SERIOUS INJURY OR DEATH.

### CAUTION

WRENCHES SHALL NOT BE USED TO TIGHTEN THE HOSE COUPLING. OVER TIGHTENING THE HOSE COUPLING MAY DAMAGE THE GASKET SEAL.

**REGULAR OPERATIONAL  
INSPECTION CONTINUED  
ON NEXT PAGE...**

## REGULAR OPERATIONAL INSPECTION CONTINUED...

### OPERATIONAL TESTING

1. Check that the breathing regulator purge valve (red knob on regulator) is closed (full clockwise and pointer on knob upward).
2. Fully depress the center of the air saver/donning switch on the top of the regulator and release.
3. Slowly open the cylinder valve by fully rotating the knob counterclockwise.
  - a) VIBRALERT alarm shall actuate and then stop.
  - b) The optional HEADS-UP DISPLAY will initialize with all five lights on for twenty seconds followed by display of cylinder supply level. If the LOW BATTERY light at the far right of the display remains lit or begins to flash, replace the batteries according to the BATTERY REPLACEMENT section of this instruction before proceeding.
  - c) If the respirator is equipped with the PASS device distress alarm, the distress alarm will be actuated when the cylinder valve is opened. Refer to Operating and Maintenance instructions of the PASS device distress alarm for the regular operational inspection of the PASS device distress alarm.
4. Check that the remote pressure gauge is operating properly and that it reads within 10% of the value on the cylinder pressure gauge.
5. Don the facepiece or hold the facepiece to the face to affect a good seal. Inhale sharply to automatically start the flow of air. Breathe normally from the facepiece to ensure proper operation.
6. Remove facepiece from face. Air shall freely flow from the facepiece.
7. Fully depress the air saver/donning switch on the top of regulator and release. The flow of air from the facepiece shall stop. Examine the complete respirator for air leaks. There shall be no leakage of air from any part of the respirator.
8. Check the purge valve:
  - a) Rotate purge valve 1/2 turn counterclockwise (pointer on knob downward). Air shall freely flow from the regulator.
  - b) Rotate purge valve 1/2 turn clockwise to full closed position (pointer on knob upward). Air flow from regulator shall stop.

### **WARNING**

**IF THE END OF SERVICE INDICATOR ALARM DOES NOT ACTUATE AS DESCRIBED IN THIS INSTRUCTION, DO NOT USE THE RESPIRATOR. REMOVE THE RESPIRATOR FROM SERVICE AND TAG IT FOR REPAIR BY AUTHORIZED PERSONNEL. USE OF AN IMPROPERLY OPERATING END OF SERVICE INDICATOR MAY RESULT IN SERIOUS INJURY OR DEATH.**

### **WARNING**

**IF THE RESPIRATOR IS EQUIPPED WITH A PASS DEVICE DISTRESS ALARM AND IT FAILS TO FUNCTION IN ACCORDANCE WITH THE INSTRUCTIONS CONCERNING REGULAR OPERATIONAL INSPECTION SUPPLIED WITH THE DISTRESS ALARM, DO NOT USE THE RESPIRATOR. REMOVE IT FROM SERVICE AND TAG FOR REPAIR BY AUTHORIZED PERSONNEL. FAILURE TO PROPERLY IDENTIFY MALFUNCTIONS MAY RESULT IN SERIOUS INJURY OR DEATH.**

9. Push in and rotate the cylinder valve knob clockwise to close. When the cylinder valve is fully closed, open the purge valve slightly to vent residual air pressure from system. As the residual air pressure vents from the system, the remote pressure gauge needle will swing from "FULL" and move towards "EMPTY." Observe the lights of the HEADS-UP DISPLAY and verify that they light properly in descending order. Close the purge valve when the gauge needle crosses the "1/4" mark but before the beginning of the red "EMPTY" band (see FIGURE 9).

CONTROL NEEDLE BETWEEN  
1/4 AND TOP OF "EMPTY"

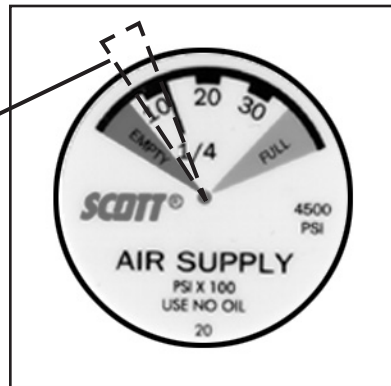

**FIGURE 7**  
Remote Gauge

- a) The VIBRALERT end of service indicator alarm shall actuate (rapid clicking).
  - b) The red light on the far left of the HEADS-UP DISPLAY shall flash rapidly at ten (10) times per second.
  - c) If installed, the PASS device with electronic end of service time indicator will actuate (audible signal from Sensor Module and flashing display "LOW AIR").
10. After verifying that all alarms are functioning, open the purge valve slightly to vent the remaining residual air pressure from the system.
    - a) All alarms shall cease operation when the system pressure drops to zero except the accessory electronic end of service time indicator.
    - b) To terminate the electronic end of service time indicator, press the Manual Reset button on the Control Console twice and then twice again after the flashing green light sequence.
  11. When air flow stops completely, return purge valve to the fully closed position (pointer on knob upward).

**IF ANY DISCREPANCY OR MALFUNCTION IS NOTED DURING THE INSPECTION, DO NOT USE THE RESPIRATOR. REMOVE THE RESPIRATOR FROM SERVICE AND TAG IT FOR REPAIR BY AUTHORIZED PERSONNEL.**

### CAUTION

**OVERTIGHTENING THE CYLINDER VALVE MAY CAUSE DAMAGE THAT COULD RESULT IN LEAKAGE OF AIR FROM THE CYLINDER. USE NO TOOLS TO CLOSE THE CYLINDER VALVE.**

### WARNING

**LEAKAGE OF AIR FROM A RESPIRATOR MAY INDICATE A POTENTIALLY SERIOUS DEFECT. AIR LEAKAGE MAY REDUCE THE DURATION OF USE AND/OR THE TIME REMAINING AFTER THE END OF SERVICE ALARM ACTUATES OR MAY PREVENT THE END OF SERVICE ALARM FROM ACTUATING. USE OF A RESPIRATOR EXHIBITING AN AIR LEAK MAY RESULT IN EXPOSING THE RESPIRATOR USER TO THE ATMOSPHERE THE RESPIRATOR IS INTENDED TO PROTECT AGAINST WHICH COULD LEAD TO SERIOUS INJURY OR DEATH.**

## USE OF THE RESPIRATOR

The following information provides the basic steps for use of the AIR-PAK 75i SCBA. Training and practice with the equipment are required before use to assure that the user is completely familiar with the operation of the respirator.

The AIR-PAK 75i SCBA must be worn over standard protective garments, but may be worn under encapsulating protective garments such as hazardous material (haz-mat) suits. Determine what other protective gear will be used and don the SCBA and the facepiece accordingly.

If respirator use is expected at temperatures near or below freezing, or if respirator is to be used after being kept at temperatures near or below freezing, refer to LOW TEMPERATURE OPERATION Section for additional information and supplemental procedures.

### **DONNING AND PREPARATION FOR USE**

1. Always check the cylinder gauge for a "FULL" indication. If the cylinder is not full, replace the cylinder before use. A gauge indication of other than full may indicate an air leak in the cylinder and valve assembly or a malfunction of the gauge assembly.
2. Always verify that the cylinder is held securely by the cylinder retention assembly.
3. If a wall storage bracket is used, follow the instructions of the bracket manufacturer for placing arms through shoulder straps and freeing the respirator from the bracket.
4. If the respirator is stored in a hard or soft storage case, place the case on the ground or level surface and open the case. Secure the regulator in the regulator holder. Proceed as shown in FIGURES 8A thru 8F.
  - a) Spread shoulder straps and fold open waist pad. Stand the respirator on the cylinder valve with cylinder toward you and the shoulder straps away from you.
  - b) Pick up the respirator and swing it around behind you as if you were donning a coat.

### **WARNING**

THE INFORMATION IN THIS INSTRUCTION IS MEANT TO SUPPLEMENT, NOT REPLACE, THE INSTRUCTIONS, TRAINING, SUPERVISION, MAINTENANCE, AND OTHER ELEMENTS OF YOUR ORGANIZED RESPIRATORY PROTECTION PROGRAM. SEE WARNING ON SECOND PAGE OF THIS DOCUMENT. FAILURE TO HEED ANY WARNINGS IN THIS INSTRUCTION MAY RESULT IN SERIOUS INJURY OR DEATH.

### **WARNING**

ALWAYS START WITH A FULL CYLINDER. PARTIALLY FILLED CYLINDERS SHOULD ONLY BE USED IN EMERGENCY CONDITIONS IF FULL CYLINDERS ARE NOT AVAILABLE. THE USER MUST DETERMINE THAT THE CYLINDER CONTAINS SUFFICIENT AIR TO ALLOW TIME FOR COMPLETION OF THE TASKS INVOLVED AND RETURN TO A SAFE ATMOSPHERE WITH AN ADEQUATE MARGIN FOR SAFETY. ENTERING A HAZARDOUS ATMOSPHERE WITH INSUFFICIENT AIR OR AFTER THE END OF SERVICE TIME INDICATOR HAS ACTUATED MAY RESULT IN SERIOUS INJURY OR DEATH.

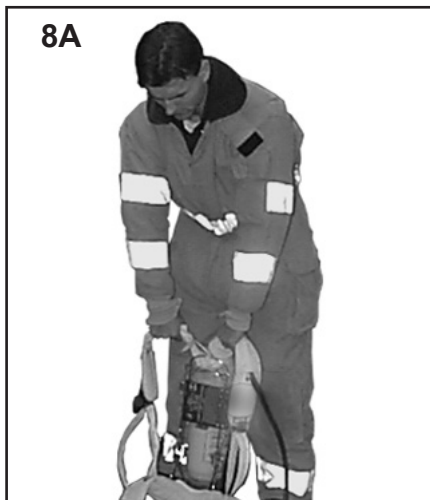

Spread shoulder straps and fold open waist pad. Stand the respirator on the cylinder valve with cylinder toward you and the shoulder straps away from you.

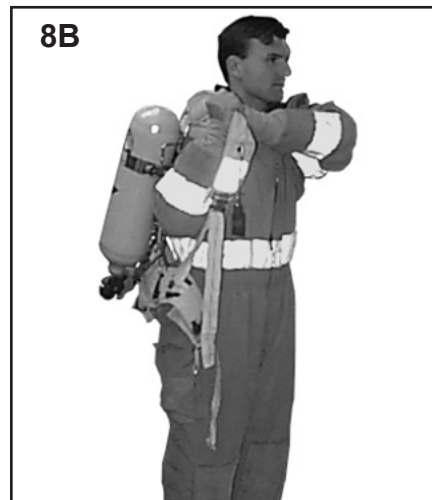

Pick up the respirator and swing it around behind you as if you were donning a coat.



- c) While leaning slightly forward, slide unit down back and pull on shoulder adjusting straps. Ensure that the shoulder pads fall into place on the shoulders.
- d) Pull down on shoulder straps to settle the unit in position on the back.

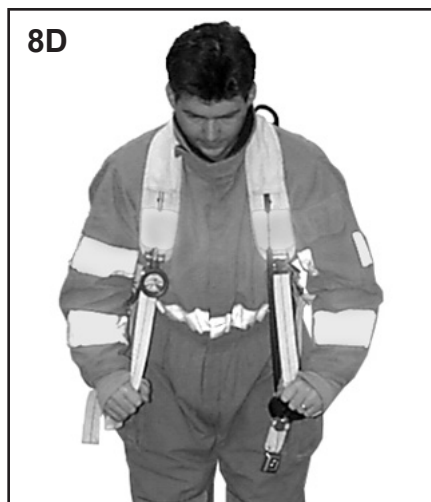
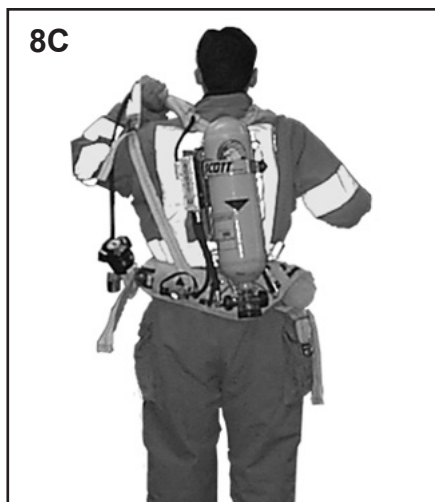

**8C**  
While leaning slightly forward, slide unit down back and pull on shoulder adjusting straps.

**8D**  
Pull down on shoulder straps to settle the unit in position on the back.

- e) While still leaning slightly forward, connect the waist belt buckle and adjust the belt by pulling forward on the two (2) side-mounted belt ends. Tuck the belt ends into the waistband. Grasp waist belt buckles. Extend waist belt and connect.
- f) Pull on belt ends to adjust waist belt for firm fit on hips.

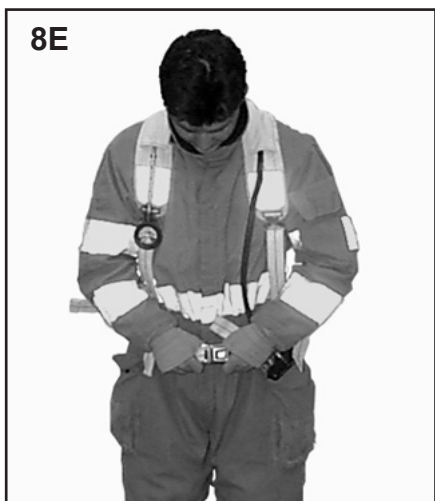

**8E**  
Grasp waist belt buckles. Extend waist belt and connect.

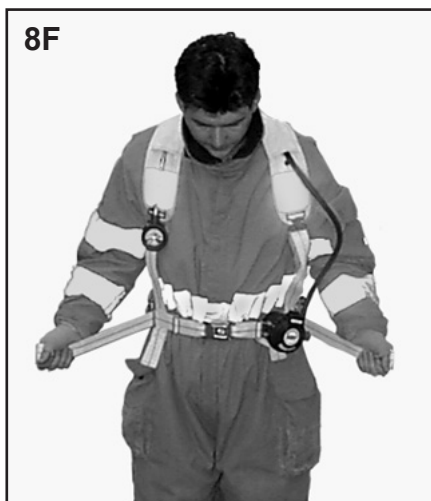

**8F**  
Pull on belt ends to adjust waist belt for firm fit on hips. Loosen shoulder straps slightly to carry weight on hips.

- g) Stand up straight and readjust the shoulder straps as needed to ensure the weight of the backframe is carried on the hips. Tuck in the ends of the shoulder straps.

### WARNING

USE OF THE RESPIRATOR WITHOUT FASTENING AND ADJUSTING THE SHOULDER STRAPS AND THE WAIST BELT AND SECURING LOOSE ENDS OF BELT AS DESCRIBED IN THIS INSTRUCTION MAY RESULT IN SHIFTING OF THE RESPIRATOR ON THE USER'S BODY, SNAGGING THE BELT, OR IN SEPARATION OF THE RESPIRATOR FROM THE USER'S BODY WHICH COULD DISTURB THE FACE TO FACEPIECE SEAL AND WHICH MAY RESULT IN EXPOSURE OF THE USER TO THE ATMOSPHERE THE RESPIRATOR IS INTENDED TO PROTECT AGAINST RESULTING IN SERIOUS INJURY OR DEATH.

**USE OF RESPIRATOR  
CONTINUED ON NEXT PAGE...**

## USE OF RESPIRATOR CONTINUED...

### **FACEPIECE DONNING PROCEDURES**

Before use of the respirator, the user must read and practice the procedures for donning, use, and termination of use. The user must be familiar with and practice the prescribed donning, leak test, use, and termination of use procedures prior to respirator use. Follow the donning instructions for the model facepiece you have.

The DONNING INSTRUCTIONS for FOUR STRAP full facepieces (such as the AV-2000, AV-3000, and the Weld-O-Vista) and the FIVE STRAP full facepieces (such as the AV-3000 SureSeal) are included in this instruction.

The respirator **MUST NOT** be worn when conditions prevent a good face to facepiece seal. Such conditions include but are not limited to:

- long hair at the forehead or the side of the face that interferes with the sealing surface or gets caught in the head harness buckles,
- facial hair such as growth of beard or sideburns, or low hairline that crosses or interferes with the sealing surface,
- thick or protruding hairstyles such as pony tails or buns that interfere with the smooth and close fit of the head harness to the head,
- temple pieces on corrective glasses,
- a skull cap that projects under the facepiece,
- excessive use of cosmetics including moisturizers, make-up, or after shave,
- the absence of one or both dentures,
- weight loss or weight gain since last fit testing,
- facial scarring,
- anything else which interferes with the face to facepiece seal or the fit of the head harness to the head.

Periodically repeating the fit testing is required to identify any physical changes of the user (such as those listed above) which could affect the fit of the facepiece.

### **NOTE**

IF THE STYLE FULL FACEPIECE RESPIRATOR MASK IS BEING DONNED FOR THE FIRST TIME OR IF THIS IS THE FIRST TIME A PARTICULAR STYLE FACEPIECE IS TO BE USED, REFER TO THE APPROPRIATE STEPS IN THE FACEPIECE FITTING SECTION OF THIS INSTRUCTION. DURING TRAINING, THE USER MUST DETERMINE THE LEVEL OF TIGHTNESS OF THE HEAD HARNESS REQUIRED TO PROVIDE THE BEST SEAL AND MOST SECURE FIT.

If the facepiece is to be used with a hood, refer to the donning instructions provided with the hood. For other head gear that will cover the facepiece head harness and/or hood, don the facepiece/hood first, then don the other head gear.

To don the facepiece and begin use of respirator, proceed as follows:

### **WARNING**

**RESPIRATORS SHALL NOT BE WORN WHEN CONDITIONS PREVENT A GOOD FACE SEAL. SUCH CONDITIONS MAY INCLUDE, BUT ARE NOT LIMITED TO, GROWTH OF BEARDS, SIDEBURNS, FACIAL HAIR OR LOW HAIRLINE THAT CROSSES OR INTERFERES WITH THE SEALING SURFACE, THICK OR PROTRUDING HAIRSTYLES SUCH AS PONY TAILS OR BUNS THAT INTERFERE WITH THE SMOOTH AND CLOSE FIT OF THE HEAD HARNESS TO THE HEAD, A SKULL CAP THAT PROJECTS UNDER THE FACEPIECE, TEMPLE PIECES ON CORRECTIVE EYE GLASSES, EXCESSIVE USE OF COSMETICS INCLUDING MOISTURIZERS, MAKE-UP, OR AFTER SHAVE, OR ANYTHING ELSE WHICH INTERFERES WITH THE FACE TO FACEPIECE SEAL. ALSO, THE ABSENCE OF ONE OR BOTH DENTURES CAN SERIOUSLY AFFECT THE FIT OF A FACEPIECE. USE OF AN IMPROPERLY FITTED FACEPIECE MAY LEAD TO EXPOSURE TO THE HAZARDOUS ATMOSPHERE WHICH COULD RESULT IN SERIOUS INJURY OR DEATH.**

## **DONNING THE FOUR STRAP FACEPIECE**

***(including: AV-2000, AV-3000, and Weld-O-Vista)***

1. Adjust the head straps to their full outward position.
2. Hold the facepiece in one hand and hold the head harness by the strap at the base of the head net.
3. Place the facepiece on the face with chin properly located in the chin pocket while pulling the head harness over the top of the head. Verify that no hair or clothing is interfering with the face to facepiece seal. See FIGURE 9-A.
4. Tighten the neck straps by pulling the two lower strap ends toward the rear of the head. See FIGURE 9-B.
5. Stroke the head harness net down the back of the head using one or both hands. Verify that the head harness is lying flat against the back of the head. Retighten the neck straps. See FIGURE 9-C.

### **NOTE**

ENSURE THAT THE CHIN IS PROPERLY LOCATED IN THE CHIN POCKET OF THE FACEPIECE THROUGHOUT THE DONNING PROCESS.

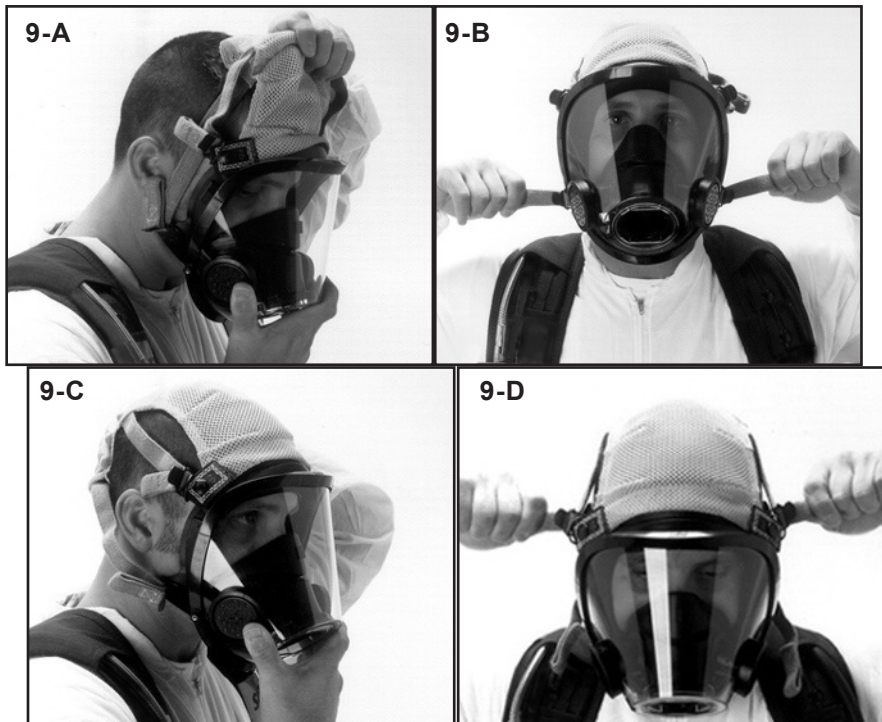

### **WARNING**

FAILURE TO DON THE FACEPIECE AND/OR FAILURE TO ADJUST THE HEAD HARNESS AS DESCRIBED IN THIS INSTRUCTION MAY RESULT IN A POOR FACE TO FACEPIECE SEAL OR MAY RESULT IN THE FAILURE OF THE FACE TO FACEPIECE SEAL DURING USE. A POOR OR FAILED FACE TO FACEPIECE SEAL MAY REDUCE THE DURATION OF USE OF THE RESPIRATOR AND/OR EXPOSE THE USER TO THE ATMOSPHERE THE RESPIRATOR IS INTENDED TO PROTECT AGAINST RESULTING IN SERIOUS INJURY OR DEATH.

### **NOTE**

VERIFY THAT THE TOP CENTER PORTION OF THE HEAD HARNESS IS POSITIONED OVER THE CROWN OF THE HEAD.

**FIGURE 9  
DONNING THE FOUR STRAP FACEPIECE**

6. Tighten the two temple straps. Adjust the temple straps by pulling the two temple strap ends toward the back of the head. Overtightening may cause discomfort. See FIGURE 9-D.
7. Retighten the neck straps if required.
8. Refer to the **DONNING PROBLEMS** section of this instruction.

**USE OF RESPIRATOR  
CONTINUED ON NEXT PAGE...**

## USE OF RESPIRATOR CONTINUED...

### **DONNING THE AV-3000 SURESEAL FACEPIECE**

1. Adjust the head straps to the full outward position.



**FIGURE 10-A  
ADJUST HEAD STRAPS OUT**

2. Hold the facepiece in one hand while holding the head harness up and out of the way with other hand. If so equipped, use the Head Harness Pull Tab on the bottom rear of the head harness.



**FIGURE 10-B  
HARNESS OUT OF WAY**

3. Place the facepiece centered on the face with the chin properly positioned in the chin cup. Verify that no hair or clothing is interfering with the face to facepiece seal. Hold the facepiece in place with the chin properly located in the chin cup throughout the donning process.



**FIGURE 10-C  
CHIN IN CHIN POCKET**

**NOTE**  
ENSURE THAT THE CHIN IS PROPERLY LOCATED IN THE CHIN POCKET OF THE FACEPIECE THROUGHOUT THE DONNING PROCESS.

4. Stroke the head harness over the head and ensure that straps are lying smooth and flat against the head and neck with no twists. Verify the head harness is centered and properly located at the back and base of the head. Maintain the head harness in this position.



**FIGURE 10-D  
HEAD HARNESS POSITION**

**NOTE**  
VERIFY THAT THE TOP CENTER PORTION OF THE HEAD HARNESS IS POSITIONED OVER THE CROWN OF THE HEAD.

5. While holding the facepiece in place with one hand, tighten the neck straps evenly one at a time by pulling each neck strap end toward the rear of the head. Alternate hands to maintain the facepiece position on the face.



**FIGURE 10-E  
HOLD AND TIGHTEN**

6. Verify the proper location of the face in the facepiece and the chin in the chin cup. While still holding the facepiece in place with one hand, tighten the temple straps evenly one at a time by pulling each temple strap end toward the rear of the head. Alternate hands to maintain the facepiece position on the face.



**FIGURE 10-F  
HOLD AND TIGHTEN**

7. Verify the proper location of the face in the facepiece and the chin in the chin cup. Tighten the forehead strap last by pulling the forehead strap toward the back of the head. Do not overtighten the forehead strap.



**FIGURE 10-G  
TIGHTEN FOREHEAD STRAP**

8. Verify that the head harness is centered on the crown of the head and lying flat against the back of the head. Verify the proper location of the face in the facepiece and the chin in the chin cup and retighten all straps as needed.



**FIGURE 10-H  
HEAD HARNESS MUST BE FLAT  
AND CENTERED**

**NOTE**

ENSURE THAT THE CHIN IS PROPERLY LOCATED IN THE CHIN POCKET OF THE FACEPIECE THROUGHOUT THE DONNING PROCESS.

**USE OF RESPIRATOR  
CONTINUED ON NEXT PAGE...**

## USE OF RESPIRATOR CONTINUED...

- Stroke the head harness down the back of the head and make sure the net is centered on your head. If necessary, adjust the head harness to the center of the crown of the head.



**CENTER HEAD HARNESS ON THE CROWN OF THE HEAD  
FIGURE 10-I**

- Verify the proper location of the face in the facepiece and the chin in the chin cup. Retighten the straps if required. All straps must be snug and the facepiece should feel secure.



**FIGURE 10-J  
RETIGHTEN IF REQUIRED**

**NOTE**  
VERIFY THAT THE TOP CENTER PORTION OF THE HEAD HARNESS IS POSITIONED OVER THE CROWN OF THE HEAD.

**NOTE**  
VERIFY THAT THE TOP CENTER PORTION OF THE HEAD HARNESS IS POSITIONED OVER THE CROWN OF THE HEAD.

- Refer to the **DONNING PROBLEMS** section of this instruction.

## **DONNING PROBLEMS**

1. Perform a personal check of the Facepiece and Head Harness and address any donning problems. OSHA standard 29 CFR 1910.134 requires teams of at least two people for situations where this type of equipment is used. Have your partner help you verify the facepiece is donned properly.

Possible problems include:

- a) Head Harness Strap twisted,
- b) Head Harness off-center or not flat against the head,
- c) Head Harness too high on the head,
- d) Hair or clothing in the face seal,
- e) Face seal rolled over inside the facepiece rather than flat against the face
- f) Facepiece is sitting too low on the face as evidenced by pressure on the forehead or the facepiece making contact with the throat area permitting a break in the seal.

The illustrations below depict the AV-3000 SureSeal, but similar conditions can occur with the AV-2000 or AV-3000 facepiece as well.



**HARNES STRAP  
TWISTED**



**HEAD HARNESS  
OFF CENTER**

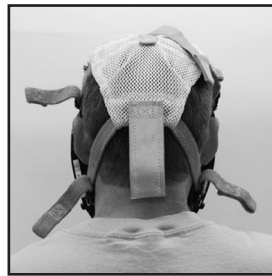

**HEAD HARNESS  
TOO HIGH**



**FACE SEAL  
ROLLED OVER**



**FACEPIECE  
TOO LOW**

**FIGURE 11  
DONNING PROBLEMS**

If any donning problems are found, remove the facepiece and re-don the facepiece correctly.

2. Proceed to BEGIN USE OF THE RESPIRATOR as instructed below.

### **WARNING**

**IF ANY DONNING PROBLEMS ARE FOUND, REMOVE THE FACEPIECE AND RE-DON IT CORRECTLY. USE OF AN IMPROPERLY DONNED FACEPIECE MAY LEAD TO EXPOSURE TO THE HAZARDOUS ATMOSPHERE WHICH COULD RESULT IN SERIOUS INJURY OR DEATH.**

**USE OF RESPIRATOR  
CONTINUED ON NEXT PAGE...**

## USE OF RESPIRATOR CONTINUED...

### **BEGIN USE OF THE RESPIRATOR**

1. Fully depress the center of the air saver/donning switch on top of regulator and release.
2. If the regulator is not attached to the facepiece, proceed as follows:
  - a) Verify that the regulator gasket is not damaged and is in place around the outlet port of the regulator.
  - b) Align the two flats of the regulator outlet port with the corresponding flats in the facepiece port (the red purge valve on the regulator will be in the 12 o'clock position). Insert the regulator into the facepiece port.
  - c) Rotate the regulator counterclockwise (as viewed from inside of facepiece) until the red purge valve knob is on the left side of the facepiece. The lock tab on the regulator will lock into the facepiece retainer with a "click." When the lock tab is properly engaged, the regulator will not rotate.
3. Slowly open cylinder valve fully by turning the valve knob counterclockwise until it stops (approximately 2 1/2 full turns of the knob).

**Install regulator on facepiece. Fully open the cylinder valve knob by turning counterclockwise (approximately 2½ turns). VIBRALERT alarm on regulator will sound momentarily.**

**FIGURE 12**

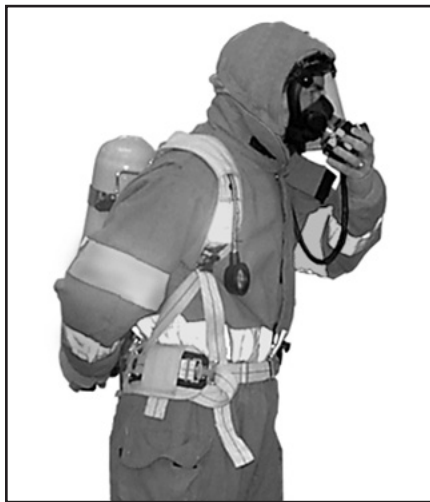

4. The VIBRALERT end of service indicator alarm will actuate and then stop. If the air saver/donning switch has not been depressed prior to opening the cylinder valve, the VIBRALERT Alarm will not actuate due to the air flowing freely on the facepiece.
5. With facepiece sealed to face, inhale sharply to actuate respirator. Air will then be supplied during inhalation.

#### **NOTE**

IF AIR IS NOT SUPPLIED ON FIRST INHALATION, CHECK THAT THE CYLINDER VALVE IS FULLY OPEN, THE REMOTE GAUGE INDICATES PRESSURE IN THE CYLINDER, AND THE FACEPIECE IS SEALED TO THE FACE.

6. Always check the facepiece seal, the system seal, and the operation of the end of service alarm using the following procedure:
  - a) Completely close the cylinder valve by pushing in on the cylinder valve and rotating it clockwise.
  - b) Breathe on respirator. As the air pressure falls in the respirator, the VIBRALERT end of service indicator alarm will actuate (rapid clicking of the VIBRALERT Alarm).
  - c) Resume breathing on the respirator until all air stops flowing from the breathing regulator. Inhale slowly and hold breath momentarily. No leakage of air shall be detected into the facepiece and the facepiece shall be drawn slightly to the face.
  - d) Open cylinder valve and breathe normally.

#### **WARNING**

THE CYLINDER VALVE MUST BE FULLY OPENED FOR PROPER OPERATION OF THE RESPIRATOR. USE OF A RESPIRATOR WITH THE CYLINDER VALVE PARTIALLY OPENED MAY CAUSE A REDUCTION OF THE AIR SUPPLIED TO THE USER AND/OR A SUDDEN AND COMPLETE LOSS OF AIR SUPPLIED TO THE USER. A REDUCTION OR LOSS OF AIR TO THE USER MAY RESULT IN EXPOSING THE USER TO THE ATMOSPHERE THE RESPIRATOR IS INTENDED TO PROTECT AGAINST.

#### **WARNING**

FAILURE TO CHECK THE FACE TO FACEPIECE SEAL BEFORE USE MAY RESULT IN USE OF THE RESPIRATOR WITH A POOR FACE TO FACEPIECE SEAL. A POOR FACE TO FACEPIECE SEAL MAY RESULT IN LOSS OF AIR WHICH MAY CAUSE REDUCED DURATION OF USE AND/OR EXPOSURE OF THE USER TO THE HAZARDOUS ATMOSPHERE WHICH COULD RESULT IN SERIOUS INJURY OR DEATH.



7. If the environment is suitably quiet, leakage from the facepiece can also be detected by listening for a flow of air while holding your breath. Inhale and hold your breath momentarily. Do not depress air saver/donning switch. Air should not be heard flowing into the facepiece from the regulator and no flow of air shall be detected outward from the facepiece.
8. If air leakage is detected during either step 6 or step 7 above, depress the air saver/donning switch on the top of the regulator, remove the facepiece and repeat the facepiece donning steps above. If a user seal check is unsatisfactory either per the user instructions above or the OSHA fit testing process, the use of Mask Seal Kit P/N 805655-01 is required. The Mask Seal Kit is provided with the full facepiece. Refer to the INSTALLATION AND USE INSTRUCTIONS, SCOTT P/N 89462-01, included with the Mask Seal Kit. This is a NIOSH approved component to enhance the fit of the facepiece. If leakage persists, do not use the respirator.

### **USING THE RESPIRATOR**

1. Put on any other required protective head gear or protective clothing. Be sure that any head gear, helmet or protective clothing does not interfere with the use of the respirator. The head must move freely without dislodging the facepiece or disturbing the face to facepiece seal.

#### **NOTE**

DO NOT ATTACH ANYTHING TO, OR CARRY ANYTHING ON, THE AIR-PAK 75i SCBA SHOULDER STRAP BUCKLES AS THIS COULD CAUSE THE SHOULDER STRAPS TO LOOSEN DURING USE OF THE RESPIRATOR.

2. Proceed with use of respirator in accordance with your respiratory protection program.
  - a) PLAN EVERY ENTRY INTO A CONTAMINATED OR UNKNOWN ATMOSPHERE TO ENSURE THAT THERE IS SUFFICIENT AIR SUPPLY TO ENTER, PERFORM THE REQUIRED TASKS, AND RETURN TO A SAFE BREATHING AREA.
  - b) THE USER MUST PERIODICALLY CHECK THE REMOTE PRESSURE GAUGE ON THE SHOULDER STRAP TO MONITOR THE RATE OF AIR CONSUMPTION AND THE REMAINING AIR SUPPLY.
  - c) THE USER MUST ALWAYS ALLOW SUFFICIENT AIR FOR EGRESS FROM THE CONTAMINATED AREA.
  - d) IF RE-ENTRY IS ATTEMPTED AFTER THE AIR HAS BEEN PARTIALLY CONSUMED (CYLINDER LESS THAN FULL), THE USER MUST BE CERTAIN THAT THE REMAINING AIR WILL BE SUFFICIENT TO PERFORM THE REQUIRED TASKS AND RETURN TO SAFETY.
3. If the VIBRALERT end of service indicator alarm actuates, LEAVE THE AREA REQUIRING RESPIRATORY PROTECTION IMMEDIATELY.
  - a) When you are in a safe area where you are certain that respiratory protection is not required, terminate the use of the respirator, (see TERMINATION OF USE section of this instruction).
  - b) Determine the cause of the alarm.
  - c) If the end of service time alarm is actuated by a depleted air supply cylinder, replace the cylinder in accordance with the CYLINDER REPLACEMENT PROCEDURE section of this instruction. Use of the respirator may be resumed with a fully charged breathing air cylinder installed.
  - d) If the end of service indicator alarm has actuated for an unknown reason, DO NOT RESUME USE OF THE RESPIRATOR. Remove the respirator from service and tag it for repair by authorized personnel.

### **WARNING**

IF LEAKAGE OF AIR INTO THE FACEPIECE IS DETECTED DURING CHECK OF THE FACE TO FACEPIECE SEAL, DO NOT USE THE RESPIRATOR. REMOVE FACEPIECE AND REPEAT THE DONNING PROCEDURE. IF FACEPIECE CANNOT BE ADJUSTED TO SEAL TO FACE, A FACEPIECE FIT TEST AND/OR A DIFFERENT SIZE FACEPIECE MAY BE REQUIRED BEFORE USE OF THE RESPIRATOR. USE OF AN IMPROPERLY FITTING FACEPIECE MAY CAUSE REDUCED DURATION OF USE AND/OR EXPOSURE OF THE USER TO THE HAZARDOUS ATMOSPHERE WHICH COULD RESULT IN SERIOUS INJURY OR DEATH.

### **WARNING**

CERTAIN ENVIRONMENTS MAY REQUIRE THAT PROTECTIVE MATERIAL COVER SOME OR ALL OF THE RESPIRATOR IN ADDITION TO COVERING THE USER. THE USER MUST BE ABLE TO ACCESS THE CONTROLS OF THE RESPIRATOR AT ALL TIMES. INABILITY TO ACCESS CONTROLS OF THE RESPIRATOR MAY RESULT IN A SITUATION WHICH COULD LEAD TO SERIOUS INJURY OR DEATH.

### **WARNING**

THE RESPIRATOR USER MUST IMMEDIATELY LEAVE THE AREA REQUIRING RESPIRATORY PROTECTION WHEN THE END OF SERVICE INDICATOR ALARM ACTUATES. ACTUATION OF ANY END OF SERVICE INDICATOR ALARM WARNS THE USER THAT APPROXIMATELY 25% OF FULL PRESSURE REMAINS IN THE AIR SUPPLY CYLINDER (THAT IS, APPROXIMATELY 3/4 OF THE TOTAL AIR SUPPLY HAS BEEN USED) OR THAT THERE IS A MALFUNCTION IN THE RESPIRATOR. A DELAY IN LEAVING THE AREA AFTER ALARM ACTUATION MAY RESULT IN SERIOUS INJURY OR DEATH.

**USE OF RESPIRATOR  
CONTINUED ON NEXT PAGE...**

## TERMINATION OF USE

To remove the facepiece (doff the facepiece) and terminate respiratory protection, proceed as follows:

1. Leave contaminated area or be certain that respiratory protection is no longer required.
2. Loosen the temple straps slightly by lifting the upper facepiece buckles away from the head. The facepiece buckles have "U-shaped" release lever extensions.
3. Loosen the neck straps by lifting the lower facepiece buckles away from the head while lifting the facepiece away from face.
4. Remove the facepiece by pulling it up and over the head.
5. To stop the flow of air from the facepiece, fully depress the air saver/donning switch on top of the regulator and release.

### NOTE

THE AIR SAVER/DONNING SWITCH IS INTENDED TO PREVENT A FREE FLOW OF AIR AND THE DEPLETION OF THE AIR SUPPLY WHEN THE FACEPIECE IS REMOVED AND THE CYLINDER VALVE IS STILL OPEN. THE PURGE VALVE AND VIBRALERT WILL FUNCTION NORMALLY WITH THE AIR SAVER/DONNING SWITCH ACTIVATED. IF THE PURGE VALVE IS OPEN OR IF THE VIBRALERT IS IN OPERATION, THE AIR WILL CONTINUE TO BE DEPLETED FROM THE RESPIRATOR UNTIL THE CYLINDER VALVE IS CLOSED.

6. Close the cylinder valve if you are not going to resume use of the respirator.

### NOTE

LEAVING THE AIR SAVER/DONNING SWITCH ACTIVATED AND THE CYLINDER VALVE OPEN FOR AN EXTENDED PERIOD OF TIME MAY RESULT IN INTERMITTENT ACTIVATION OF THE VIBRALERT EVEN WHEN MORE THAN 25% OF THE AIR SUPPLY REMAINS.

### NOTE

IF THE RESPIRATOR IS EQUIPPED WITH A PASS DEVICE DISTRESS ALARM, SEE THE INSTRUCTIONS PROVIDED WITH THE PASS DEVICE DISTRESS ALARM FOR DETAILS OF HOW TO TURN OFF THE UNIT.

7. Slightly loosen shoulder straps by lifting ends of shoulder strap slide buckles up, release waist belt by pressing release button in center of waist belt buckle, and remove the unit from your back.
8. Proceed in accordance with the requirements of your respiratory protection program for service of the respirator, including the following:
  - a) Replace the cylinder with a fully charged cylinder (see the CYLINDER REPLACEMENT Section of this instruction)
  - b) Clean the respirator according to the CLEANING AND STORAGE section of this instruction and inspect according to the REGULAR OPERATIONAL INSPECTION section of this instruction.

## CAUTION

FAILURE TO RELEASE TENSION ON NECK STRAPS BEFORE REMOVING FACEPIECE MAY CAUSE PREMATURE WEAR OR DAMAGE TO STRAPS AND/OR FACEPIECE ASSEMBLY.

## WARNING

IF AIRFLOW FROM THE REGULATOR CANNOT BE STOPPED BY DEPRESSING THE AIR SAVER SWITCH, IMMEDIATELY CLOSE THE CYLINDER VALVE TO PREVENT DEPLETION OF THE AIR REMAINING IN THE CYLINDER. REMOVE THE RESPIRATOR FROM SERVICE AND TAG FOR REPAIR BY AUTHORIZED PERSONNEL.

## CAUTION

OVERTIGHTENING THE CYLINDER VALVE MAY CAUSE DAMAGE THAT COULD RESULT IN LEAKAGE OF AIR FROM THE CYLINDER. USE NO TOOLS TO CLOSE THE CYLINDER VALVE.

## CAUTION

AN IMPACT TO THE REGULATOR WHILE THE CYLINDER VALVE IS OPEN AND THE AIR SAVER SWITCH IS ACTIVATED MAY CAUSE AIR TO FLOW FROM THE REGULATOR AND DEplete THE AIR REMAINING IN THE CYLINDER.

## CAUTION

DO NOT LEAVE CYLINDER VALVE OPEN WHEN RESPIRATOR IS NOT IN USE.

## CAUTION

FAILURE TO RELEASE TENSION ON SHOULDER STRAPS BEFORE REMOVING RESPIRATOR MAY CAUSE PREMATURE WEAR OR DAMAGE TO STRAPS AND/OR RESPIRATOR ASSEMBLY.

## WARNING

DO NOT ALLOW RESPIRATOR TO DROP WHEN HANDLING. CARELESS HANDLING OF THE RESPIRATOR MAY CAUSE DAMAGE TO RESPIRATOR THAT MAY EFFECT THE PERFORMANCE OF THE RESPIRATOR OR MAY RELEASE HIGH PRESSURE BREATHING AIR, EITHER OF WHICH MAY RESULT IN SERIOUS INJURY OR DEATH.

### **TO RESUME USE OF THE RESPIRATOR**

If you must resume use of the respirator, proceed as follows:

1. NEVER resume use of a respirator where the end of service indicator alarm was activated without first determining and correcting the reason for the end of service indicator alarm.
2. Make sure that the remaining air supply in the cylinder is sufficient to accomplish the purpose for which respirator use has been resumed. As a general rule, replace partially depleted cylinders with full cylinders before respirator use is resumed.
3. To resume use of the respirator, repeat the respirator and facepiece donning procedures as defined in the USE OF RESPIRATOR section of this instruction.
4. When operations using the respirator are complete, leave contaminated area or be certain that respiratory protection is no longer required and proceed with the TERMINATION OF USE steps described above.

### **WARNING**

**IF RESPIRATOR USE IS RESUMED AFTER THE AIR HAS BEEN PARTIALLY CONSUMED (CYLINDER LESS THAN FULL), YOU MUST BE CERTAIN THAT THE REMAINING AIR WILL BE SUFFICIENT FOR YOUR SAFETY. (SEE STEP 2 IN USING THE RESPIRATOR SECTION.)**

## RIC UAC EMERGENCY USE

This AIR-PA 75i respirator may be fitted with a Rapid Intervention Crew/Company Universal Air Connection (RIC UAC) System which permits emergency replenishment of an approved SCBA breathing air supply cylinder on a user's respirator from an approved air supply source while in use. This is not a Quick Charge attachment and must not be used for routine recharging of the cylinder, for "buddy breathing", for transferring air from another SCBA, or any unapproved use. The RIC UAC is for **emergency use only** when the respirator user is incapacitated within the hazardous atmosphere. The RIC UAC manifold is equipped with a relief valve which will open if the supply pressure of the emergency air supply exceeds the maximum pressure rating of the complete respirator. See FIGURE 13. However, the supply pressure of the emergency air supply to be connected to the RIC UAC must not exceed 4500 psig.

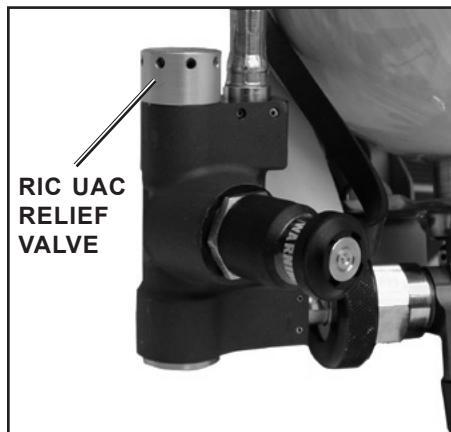

FIGURE 13



FIGURE 14

To use the RIC UAC system proceed as follows:

1. A member of the Rapid Intervention Crew/Company must visually inspect the respirator user's cylinder and cylinder valve for dents or gouges in the metal or fiber wrapping. If the cylinder and valve assembly shows damage or evidence of exposure to high heat or flame, such as paint turned brown or black, decals charred or missing, gauge lens melted or elastomeric bumper distorted, the decision must be made whether the cylinder is suitable for recharging by this method. If there is any suspicion that the cylinder is not safe, find another method of supplying air to the respirator user.
2. Be certain that the cylinder which you are charging is compatible with the complete respirator it is installed on, (i.e.: there must be a 2216 psig cylinder installed on a Model 2.2 respirator; there must be a 4500 psig cylinder installed on a Model 4.5 respirator, etc.). Verify by inspecting the cylinder and reducer labels to ensure that they are rated at the same pressure. NEVER ATTEMPT TO CHARGE A CYLINDER TO MORE THAN THE RATED PRESSURE MARKED ON THE CYLINDER.
3. The RIC UAC filling hose assembly must be regulated to a **maximum** supply pressure of 4500 psig.
4. Verify that the cylinder valve on the user's respirator is fully open by turning the cylinder valve knob fully counterclockwise (approximately 2 1/2 full turns).
5. Remove the dust cap from the RIC UAC coupling on the respirator and from the matching coupling on the RIC UAC filling hose assembly. Visually inspect both couplings for dirt or damage. Remove any dirt or contamination from the couplings.
  - a) If the RIC UAC filling hose assembly coupling appears damaged, do not attempt to connect the RIC UAC filling hose assembly to the respirator. Find an alternate RIC UAC filling hose assembly.
  - b) If the RIC UAC coupling on the respirator appears damaged, do not attempt to connect the RIC UAC filling hose assembly to the respirator. Find an alternate method of supplying air to the respirator user.

## WARNING

THE RIC UAC SYSTEM IS FOR EMERGENCY USE ONLY. IMPROPER USE OF THIS SYSTEM MAY LEAD TO A MALFUNCTION OF THE EQUIPMENT WHICH COULD CAUSE SERIOUS INJURY OR DEATH. DO NOT USE THE SCOTT RIC UAC ASSEMBLY TO CHARGE AN SCBA AIR CYLINDER WHILE THE SCBA IS BEING WORN UNLESS THERE IS A COMPELLING REASON TO ASSUME THE RISK OF INJURY IF THERE IS A COMPONENT FAILURE DURING THE FILL PROCESS. A COMPONENT FAILURE DURING OR AFTER THE FILL PROCESS MAY RESULT IN SERIOUS INJURY OR DEATH.

## WARNING

DO NOT USE THE SCOTT QUICK CHARGE ASSEMBLY TO CHARGE AN SCBA AIR CYLINDER WHILE THE SCBA IS BEING WORN IN A HAZARDOUS OR AN IDLH ATMOSPHERE UNLESS THERE IS A COMPELLING REASON TO ASSUME THE RISK OF INJURY IF THERE ARE ANY IRREGULARITIES IN THE FILL PROCESS WHICH MAY RESULT IN A NEED TO REMOVE THE RESPIRATOR. REMOVAL OF THE RESPIRATOR IN A HAZARDOUS OR AN IDLH ATMOSPHERE MAY RESULT IN SERIOUS INJURY OR DEATH.

## WARNING

IF THE SCBA OR THE CYLINDER TO BE CHARGED IS KNOWN OR SUSPECTED OF HAVING BEEN DROPPED, EXPOSED TO DIRECT FLAME IMPINGEMENT OR DAMAGED IN ANY WAY, DO NOT USE THE RIC UAC SYSTEM. FIND ANOTHER METHOD OF SUPPLYING BREATHING AIR TO THE RESPIRATOR USER. ATTEMPTING TO FILL A CYLINDER WHICH IS KNOWN OR SUSPECTED OF DAMAGE IN ANY WAY MAY RESULT IN CYLINDER FAILURE WHICH COULD CAUSE SERIOUS INJURY OR DEATH.

## WARNING

NEVER CHARGE A CYLINDER TO MORE THAN THE RATED PRESSURE MARKED ON THE CYLINDER. OVERCHARGING A CYLINDER MAY CAUSE A FAILURE RESULTING IN RAPID RELEASE OF HIGH PRESSURE AIR WHICH COULD CAUSE SERIOUS INJURY OR DEATH.

6. Connect the RIC UAC filling hose assembly by pushing the quick disconnect coupling on the RIC UAC filling hose assembly on to the coupling on the respirator until the quick disconnect sleeve "clicks" into place. See FIGURE 14.
7. Slowly open the RIC UAC filling hose assembly valve to pressurize the supply line and begin air flow to the cylinder.

**NOTE**

WHEN THE REGULATED FILLING PRESSURE IS HELD CONSTANT AT THE CYLINDER RATED PRESSURE THROUGHOUT THE CHARGING CYCLE THE FLOW MUST BE MONITORED TO NOT EXCEED 1500 PSIG/MINUTE FOR MOST CYLINDER AND VALVE ASSEMBLIES.

**NOTE**

IF AT ANY TIME DURING THE FILLING PROCESS A LEAK IS DETECTED, IMMEDIATELY DISCONTINUE THE FILLING PROCEDURE AND LEAVE THE IDLH ATMOSPHERE.

8. Continually monitor the pressure gauge on the respirator user's cylinder while filling. When the pressure gauge on the user's cylinder reads "FULL," immediately terminate filling and disconnect the air supply source. A check valve in the RIC UAC coupling on the respirator will prevent air from flowing out of the respirator user's cylinder.
  - a) If the respirator user's cylinder is being filled from a portable air supply cylinder (such as a SCOTT RIT-PAK portable air supply), the air from the supply cylinder will stop flowing when the pressure in the respirator user's cylinder equals the remaining pressure in the portable air supply (pressures will balance). Disconnect the RIC UAC filling hose assembly.
  - b) If the respirator user's cylinder is being filled from a supply hose connected to a high pressure air supply source, extra care is required to prevent over filling the respirator user's cylinder. If the supply pressure exceeds the pressure rating for the complete respirator, the RIC UAC relief valve will open when the respirator user's cylinder is full and will reset after the high pressure air supply is disconnected. The cylinder pressure gauge should indicate "full" at this time. Disconnect the RIC UAC filling hose assembly.

**NOTE**

THE RIC UAC MANIFOLD IS FITTED WITH A RELIEF VALVE TO VENT AIR IF THE RATED PRESSURE OF THE RESPIRATOR IS EXCEEDED. IF THIS OCCURS, SHUT OFF THE AIR FROM THE RIC UAC FILLING HOSE ASSEMBLY AND DISCONNECT THE AIR SUPPLY. THE RELIEF VALVE WILL RESET AFTER EXCESS PRESSURE IS RELEASED.

**NOTE**

THE RIC UAC ASSEMBLY IS DESIGNED WITH INTEGRAL PROTECTION DEVICES. DO NOT DISASSEMBLE OR MODIFY ANY PART OF THIS ASSEMBLY.

9. When charging is complete, disconnect the RIC UAC filling hose assembly from the RIC UAC coupling on the respirator. To disconnect RIC UAC filling hose assembly, pull the coupling sleeve away from the respirator until the coupling disengages. Install the dust caps on the RIC UAC coupling and on the RIC UAC filling hose assembly coupling.
10. Charging the cylinder will increase the temperature of the air within the cylinder. When charging is complete and the cylinder cools to ambient temperature, the pressure within the cylinder will fall slightly. If practical in the situation, top off the cylinder to ensure optimum service time.

**NOTE**

IF CHARGING IN COLD AMBIENT CONDITIONS WHERE THE TEMPERATURES ARE BELOW FREEZING, SEE THE **USE OF THE RIC UAC IN LOW TEMPERATURE** SECTION OF THIS INSTRUCTION.

11. After charging is complete, monitor the cylinder pressure on the respirator and repeat the above procedure as needed until the respirator user can be removed from the hazardous atmosphere.

**WARNING**

IF AT ANY TIME DURING THE FILLING PROCESS A LEAK IS DETECTED, IMMEDIATELY DISCONTINUE THE FILLING PROCEDURE AND LEAVE THE IDLH ATMOSPHERE. CONTINUING TO FILL A RESPIRATOR THAT HAS EXHIBITED A LEAK MAY CAUSE A FAILURE OF THE EQUIPMENT WHICH MAY RESULT IN SERIOUS INJURY OR DEATH.

## EMERGENCY OPERATION

The respirator is automatic in function. It requires only the opening of the cylinder valve and the proper donning of the facepiece to begin use, and the closing of the cylinder valve to end use. If there is a malfunction or a suspected malfunction, use one of the emergency procedures listed below:

1. If the VIBRALERT end of service time indicator alarm actuates during use, even if the air supply has not been depleted to approximately 25% of full rated capacity, LEAVE THE CONTAMINATED AREA AT ONCE.

### NOTE

IF THE VIBRALERT ACTUATES BEFORE THE AIR SUPPLY IS DEPLETED TO APPROXIMATELY 25% OF FULL RATED CAPACITY, IT MAY INDICATE A FAILURE OF THE PRIMARY REDUCER PATH IN THE PRESSURE REDUCER, A MALFUNCTIONING REMOTE AIR SUPPLY GAUGE, OR A FAILURE OF THE END OF SERVICE INDICATOR ALARM. LEAVE THE AREA REQUIRING RESPIRATORY PROTECTION IMMEDIATELY WHEN THE ALARM IS ACTUATED.

2. If the air supply is partially or completely cut off during use, fully open the red purge valve on the regulator by turning it counterclockwise (pointer on knob downward) and check to be sure the cylinder valve is fully opened (turned fully counterclockwise). LEAVE THE CONTAMINATED AREA AT ONCE AFTER OPENING THE PURGE VALVE.
3. If the air supply begins to flow freely into the facepiece during use, fully open the red purge valve knob on the regulator by turning it counterclockwise (pointer on knob downward). Partially close the cylinder valve by pushing in and rotating clockwise to regulate the flow of air to satisfy the requirements of the user. Do not close the cylinder valve completely. LEAVE THE CONTAMINATED AREA AT ONCE AFTER PARTIALLY CLOSING CYLINDER VALVE.
4. If there is a blockage of air flow or sudden and complete loss of the system air supply so that there is total loss of respiratory protection, LEAVE THE CONTAMINATED AREA AT ONCE. USE ALL NECESSARY PRECAUTIONS AND FOLLOW EMERGENCY PROCEDURES PRESCRIBED BY YOUR ESTABLISHED RESPIRATORY PROTECTION PROGRAM.

If any of the above procedures are used, REMOVE THE RESPIRATOR FROM SERVICE AND TAG FOR REPAIR BY AUTHORIZED PERSONNEL.

## WARNING

THESE EMERGENCY OPERATION PROCEDURES ARE FOR EMERGENCY USE ONLY AND ARE MEANT TO SUPPLEMENT, NOT REPLACE, THE EMERGENCY PROCEDURES PRESCRIBED BY YOUR RESPIRATORY PROTECTION PROGRAM. IF THEIR USE IS REQUIRED, LEAVE THE HAZARDOUS AREA AT ONCE. USE OF THESE EMERGENCY PROCEDURES WILL INCREASE THE RATE OF CONSUMPTION OF THE AIR SUPPLY AND MAY CAUSE THE END OF SERVICE INDICATOR ALARM TO DIMINISH IN INTENSITY OR STOP COMPLETELY. FAILURE TO LEAVE THE HAZARDOUS AREA IMMEDIATELY MAY RESULT IN SERIOUS INJURY OR DEATH.

## WARNING

THE AIRFLOW THROUGH THE RESPIRATOR WHEN THE PURGE VALVE IS IN USE CAN EXCEED 200 LITERS PER MINUTE. TO REDUCE AIR CONSUMPTION, THE AIRFLOW MAY BE REDUCED BY PARTIALLY CLOSING THE PURGE VALVE. FAILURE TO LEAVE THE HAZARDOUS AREA WHEN THE PURGE VALVE IS IN USE MAY RESULT IN A SUDDEN TERMINATION OF BREATHING AIR WHICH COULD CAUSE SERIOUS INJURY OR DEATH.

## WARNING

EMERGENCY PROCEDURE #3 IS THE ONLY TIME THE RESPIRATOR MAY BE OPERATED WITH THE CYLINDER VALVE LESS THAN FULLY OPENED.

## LOW TEMPERATURE OPERATION

Respirators intended for routine use and respirators not routinely used but kept for emergency use shall be located in areas where the temperature is maintained above freezing (32° F / 0° C).

If a respirator may be unavoidably kept at a temperature below freezing before the next use, special care **MUST** be exercised to be certain that all components of the respirator are **THOROUGHLY DRIED** after cleaning and before storage.

If a respirator has been unavoidably kept at a temperature below freezing and it is not possible to bring it to room temperature before it is to be used, do not exhale into the facepiece until the facepiece is completely donned and the nose cup is properly in place against the face.

If, after using the respirator, the facepiece is doffed in a safe breathing area which is at temperatures near or below freezing, place the facepiece with regulator connected under outerwear to keep it warm next to the body in case respirator reuse is required.

Whenever the respirator is in place but not in use in areas at or below freezing, the facepiece and regulator **MUST** be protected against exposure to water.

## USE OF THE RIC UAC IN LOW TEMPERATURE

Keep the high pressure air inlet of the RIC UAC coupling dry at all times. Water on the inlet may freeze preventing connection to the RIC UAC filling hose assembly or preventing removal of the RIC UAC filling hose assembly once connected.

If the RIC UAC filling hose assembly is used to fill a respirator cylinder in temperatures less than 32° F / 0° C and the full respirator is then moved indoors to warmer temperatures, the pressure in the cylinder **MUST BE CHECKED FOR EXCESS PRESSURE** within two hours after the respirator is moved indoors. If the pressure gauge on the cylinder is reading above "full", excess pressure must be removed from the cylinders by releasing air from the respirator until the pointer of the gauge is reading "full".

## WARNING

USE OF THIS RESPIRATOR AT TEMPERATURES AT OR BELOW FREEZING (32°F / 0° C) WITHOUT FOLLOWING THE LOW TEMPERATURE OPERATION INSTRUCTIONS MAY RESULT IN OBSCURED VISION AND/OR PARTIAL OR COMPLETE BLOCKAGE OF THE AIRFLOW WHICH COULD LEAD TO SERIOUS INJURY OR DEATH.

## WARNING

A PROPERLY INSTALLED NOSE CUP ASSEMBLY IS REQUIRED FOR USE OF THIS RESPIRATOR IN TEMPERATURES AT OR BELOW FREEZING (32° F / 0° C). FAILURE TO USE THE NOSE CUP MAY CAUSE OBSCURED VISION AND/OR PARTIAL OR COMPLETE BLOCKAGE OF THE AIRFLOW WHICH COULD RESULT IN SERIOUS INJURY OR DEATH.

## WARNING

RESPIRATORS MUST BE THOROUGHLY DRY BEFORE AND DURING STORAGE. MOISTURE ON A RESPIRATOR IN BELOW FREEZING TEMPERATURES MAY CAUSE A MALFUNCTION OF THE RESPIRATOR WHICH COULD RESULT IN SERIOUS INJURY OR DEATH.

## WARNING

IF A RESPIRATOR CYLINDER IS FILLED IN TEMPERATURES LESS THAN 32° F / 0° C AND THE FULL RESPIRATOR IS THEN MOVED INDOORS TO WARMER TEMPERATURES, THE PRESSURE IN THE CYLINDER MUST BE CHECKED FOR EXCESS PRESSURE WITHIN TWO HOURS AFTER THE RESPIRATOR IS MOVED INDOORS. FAILURE TO VERIFY THAT CYLINDER PRESSURE DOES NOT EXCEED THE RECOMMENDED MAXIMUM FOR THE CYLINDER MAY RESULT IN A SUDDEN RELEASE OF HIGH PRESSURE AIR WHICH COULD CAUSE SERIOUS INJURY OR DEATH.

## CYLINDER REPLACEMENT PROCEDURE

Depleted or partially depleted SCBA cylinders must be replaced with full cylinders as soon as possible. In normal practice, the user removes the respirator assembly and places it on solid support to change the cylinder. Cylinder replacement may also be performed while the user is wearing the respirator assembly with the assistance of a second individual.

Use only cylinders of the correct rated pressure for the respirator.

- Model 2.2 SCBA's must use only cylinder and valve assemblies marked for 2216 psig service (30 minute rated only)
- Model 4.5 SCBA's must use only cylinder and valve assemblies marked for 4500 psig service (30 minute, 45 minute, or one hour rated)

Always inspect the cylinder valve assembly and the threads on the cylinder valve assembly before connecting the pressure reducer hose coupling. Never use a cylinder with a damaged cylinder valve assembly or a cylinder valve assembly with damaged threads.

To replace a depleted or partially depleted cylinder, proceed as follows:

1. Leave the area requiring respiratory protection and be certain that respiratory protection is no longer required.
2. Do off the facepiece. (See TERMINATION OF USE section of this instruction.)
3. Push in and rotate the cylinder valve knob clockwise and completely close the cylinder valve.
4. Release residual air pressure in the respirator system by opening the purge valve slightly. When the flow of air from the facepiece has stopped, fully close the purge valve.
5. Unthread the pressure reducer hose coupling from the cylinder valve by rotating counterclockwise.

### NOTE

ALL SCOTT AIR-PAK 75i RESPIRATORS DESCRIBED IN THIS INSTRUCTION USE A SPRING LOADED CYLINDER LOCKING TAB LOCATED AT THE BOTTOM OF THE BACKFRAME. THE LOCKING TAB ENGAGES A HANGER TAB WHICH IS PART OF THE VALVE ASSEMBLY ON ALL SCOTT CYLINDER AND VALVE ASSEMBLIES.

6. Disengage the cylinder retention strap by gripping the latch plate as shown in FIGURE 15 and lifting on the end of the latch.

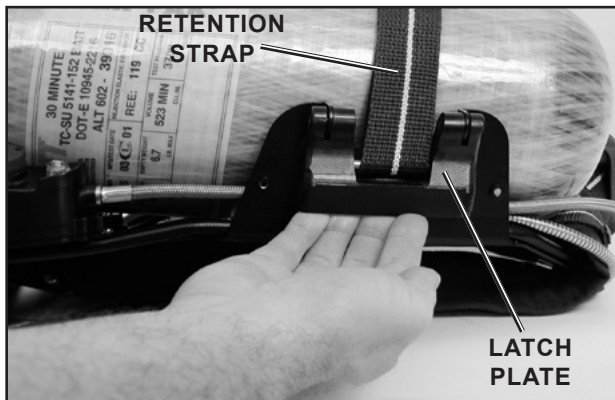

**FIGURE 15**  
**CYLINDER RETENTION**

7. Grasp the cylinder below the retention strap, push the locking tab below the valve, then lift the cylinder free from the bottom hook and remove. See FIGURE 16.

## WARNING

THE USE OF ANY AIR CYLINDER OTHER THAN A CYLINDER AND VALVE ASSEMBLY APPROVED FOR USE WITH THE SPECIFIC SCOTT AIR-PAK 75i RESPIRATOR MODEL BEING SERVICED MAY RESULT IN LOSS OF AIR FROM THE CYLINDER OR IMPROPER OPERATION OF THE RESPIRATOR.

SEE THE COMPLETE NIOSH APPROVAL LABEL (SCOTT DOCUMENT 89347-01) SUPPLIED WITH THESE INSTRUCTIONS FOR CYLINDER AND VALVE ASSEMBLIES APPROVED FOR USE WITH SPECIFIC SCOTT AIR-PAK 75i MODELS.

## CAUTION

OVERTIGHTENING THE CYLINDER VALVE MAY CAUSE DAMAGE THAT COULD RESULT IN LEAKAGE OF AIR FROM THE CYLINDER. USE NO TOOLS TO CLOSE THE CYLINDER VALVE.

## WARNING

NEVER USE A DAMAGED CYLINDER OR A CYLINDER WITH A DAMAGED CYLINDER VALVE ASSEMBLY OR A CYLINDER VALVE ASSEMBLY WITH DAMAGED THREADS. LEAKAGE MAY OCCUR WHICH COULD CAUSE A LOSS OF BREATHING AIR OR A SUDDEN RELEASE OF HIGH PRESSURE AIR RESULTING IN SERIOUS INJURY OR DEATH.





**FIGURE 16**  
**Locking tab mechanism**

8. Replace with a fully charged cylinder and valve assembly of the same pressure rating. Slide the top of the cylinder upward under the strap.
9. Engage the cylinder hanger in the hook at the bottom of the backframe.

**NOTE**

FOR 4500 PSI RESPIRATORS: IF A DIFFERENT DURATION OR DIAMETER CYLINDER IS USED, USE THE TRI-SLIDE BUCKLE TO ADJUST THE RETENTION STRAP SO THAT IT PRESSES TIGHTLY AGAINST THE CYLINDER WHEN THE LATCH ASSEMBLY IS FULLY ENGAGED. THE USER SHOULD NOT BE ABLE TO MOVE RETENTION STRAP UP AND DOWN ON THE CYLINDER WITH THEIR FINGERS WHEN THE LATCH ASSEMBLY IS FULLY CLOSED.

10. Secure the cylinder in place by pushing the latch toward the backframe to lock the cylinder latch and fully engage the cylinder latch assembly.

**NOTE**

ENSURE THAT THE CYLINDER IS SECURELY HELD IN PLACE ON THE BACKFRAME BY THE CYLINDER RETENTION ASSEMBLY. DO NOT USE EXCESSIVE FORCE TO LOCK THE LATCH MECHANISM. IF THE RETENTION STRAP IS TOO TIGHT OR TOO LOOSE, USE THE TRI-SLIDE BUCKLE TO ADJUST THE RETENTION STRAP ENGAGEMENT LENGTH, THEN RE-ATTEMPT TO ENGAGE THE LATCH ASSEMBLY.

11. Inspect the high pressure coupling and verify that the gasket seal is present and undamaged. See FIGURE 17.



**FIGURE 17**  
**High pressure gasket seal**

If the gasket is present and undamaged, align the high pressure coupling with the outlet of the cylinder valve and tighten the hose coupling to the cylinder valve by hand.

12. The respirator is ready for continued use. See the PREPARATION FOR USE section of this instruction and USE OF THE RESPIRATOR section of this instruction. If respirator use is not continued, the respirator must be cleaned and inspected. See the CLEANING AND STORAGE section of this instruction.
13. The removed cylinder shall be inspected and refilled by authorized personnel. See SCOTT *Specialist Level Maintenance Modules*, available on request from SCOTT Safety, for further information.

**CAUTION**  
DO NOT LEAVE THE CYLINDER VALVE OPEN WHEN THE RESPIRATOR IS NOT IN USE.

**WARNING**  
USE OF A RESPIRATOR WITH A MISSING OR DAMAGED COUPLING GASKET MAY RESULT IN AIR LEAKAGE WHICH MAY REDUCE THE DURATION OF USE AND/OR THE TIME REMAINING AFTER THE END OF SERVICE ALARM ACTUATES OR MAY PREVENT THE END OF SERVICE ALARM FROM ACTUATING. THE USE OF A RESPIRATOR WITH SUCH AN AIR LEAK MAY RESULT IN EXPOSURE OF THE USER TO THE ATMOSPHERE THE RESPIRATOR IS INTENDED TO PROTECT AGAINST WHICH MAY LEAD TO SERIOUS INJURY OR DEATH.

**CAUTION**  
WRENCHES SHALL NOT BE USED TO TIGHTEN THE HOSE COUPLING. OVER TIGHTENING THE HOSE COUPLING MAY DAMAGE THE GASKET SEAL.

**CAUTION**  
ALWAYS CLOSE THE CYLINDER VALVE ON "EMPTY" CYLINDERS. AN OPEN VALVE MAY ALLOW MOISTURE OR OTHER CONTAMINANTS TO ENTER THE CYLINDER.

**CYLINDER REPLACEMENT  
CONTINUED ON NEXT PAGE...**

## **CLEANING AND STORAGE**

Do not attempt any repair or alteration of this respirator beyond the scope of this instruction without proper training.

### **NOTE**

IF DURING USE, THE RESPIRATOR IS SUSPECTED OF BEING CONTAMINATED BY HAZARDOUS SUBSTANCE, THE CONTAMINANT MUST BE IDENTIFIED AND PROPERLY REMOVED OR THE CONTAMINATED COMPONENT(S) MUST BE REPLACED BEFORE NEXT USE. DISPOSE OF THE CONTAMINANTS OR THE CONTAMINATED COMPONENT(S) IN ACCORDANCE WITH APPLICABLE REGULATORY REQUIREMENTS.

After each use of the respirator, clean according to these instructions and perform a REGULAR OPERATIONAL INSPECTION. If any damage is found, remove the respirator from service and tag for repair by authorized personnel.

### **CLEANING THE RESPIRATOR**

1. Damp sponge dirt accumulations from the exterior of the respirator.
2. If respirator has been exposed to potentially hazardous materials, decontaminate in accordance with established procedures.
3. Clean the facepiece and mask mounted regulator as described below.

### **CLEANING THE FACEPIECE**

Supplies needed:

- SCOTT recommended sanitizing or disinfecting cleaner

### **NOTE**

DO NOT USE A QUATERNARY AMMONIA (AMMONIUM CHLORIDE) TYPE OF CLEANER.

- Drinking (potable) water - running or in a spray bottle
- Air supply of lubricant free, dry breathing air, maximum 30 psig, for drying

### **NOTE**

FOLLOW ALL THE INSTRUCTIONS AND THE MSDS (MATERIAL SAFETY DATA SHEET) PROVIDED WITH THE SANITIZING OR DISINFECTING CLEANER.

1. With the regulator removed, carefully wash the facepiece assembly with SCOTT recommended cleaner according to the instructions provided with the cleaner and thoroughly rinse in clean water. If the facepiece is heavily soiled, it may be necessary to first wash the facepiece with a solution of mild soap or detergent in warm water (110° F / 44° C maximum).

### **NOTE**

A NOSE CUP IS DESIGNED TO BE AN INTEGRAL PART OF THE FACEPIECE AND DOES NOT NEED TO BE REMOVED FOR CLEANING.

2. To sanitize or disinfect the facepiece, use the SCOTT recommended sanitizing or disinfecting cleaner according to the instructions provided with the cleaner. Sanitizing or disinfecting may require a specific contact time of the cleaner prior to rinsing.

### **NOTE**

THE KEVLAR AND NYLON HEAD HARNESSSES ARE MADE OF POROUS MATERIAL. SCOTT RECOMMENDED CLEANER MAY NOT BE EFFECTIVE ON POROUS MATERIAL.

3. Rinse with drinking water using a spray bottle or running water.
4. Shake excess water off of facepiece and then dry with a clean, lint free cloth or gently blow dry with clean, dry breathing air of 30 psig or less pressure. Do not use shop air or any other air containing lubricants or moisture.

## **WARNING**

DO NOT ATTEMPT ANY REPAIR OR ALTERATION OF THIS RESPIRATOR BEYOND THE SCOPE OF THIS INSTRUCTION. TRAINING IS REQUIRED FOR FURTHER SERVICE OR REPAIR OF THIS RESPIRATOR. THIS RESPIRATOR MAY SUPPORT LIFE IN HAZARDOUS ATMOSPHERES. FAILURE TO PROPERLY SERVICE THIS RESPIRATOR MAY RESULT IN SERIOUS INJURY OR DEATH.

## **CAUTION**

CERTAIN CLEANING AND DISINFECTING AGENTS SUCH AS QUATERNARY AMMONIUM COMPOUNDS (AMMONIUM CHLORIDES) MAY CAUSE DAMAGE, DETERIORATION OR ACCELERATED AGING TO PARTS OF THE RESPIRATOR. USE ONLY THE RECOMMENDED CLEANING AND DISINFECTING AGENTS.

## **WARNING**

KEEP ALL SANITIZING OR DISINFECTING CLEANERS OUT OF REACH OF CHILDREN. USE THE CLEANER ONLY IN A MANNER CONSISTENT WITH THE PRODUCT LABELING AND USE INSTRUCTIONS. IMPROPER USE OR HANDLING OF THIS PRODUCT MAY RESULT IN SERIOUS INJURY OR DEATH.

## **CLEANING THE MASK MOUNTED REGULATOR**

### **NOTE**

AFTER CLEANING THE REGULATOR, VERIFY THAT ALL MOISTURE HAS BEEN REMOVED FROM THE REGULATOR AS DESCRIBED IN THE **REGULATOR CHECK** SECTION OF THIS INSTRUCTION.

1. Remove the breathing regulator from the facepiece by pulling back on the locking clip and rotating the regulator 1/4 turn clockwise.
2. Remove any obvious dirt from the external surfaces of the regulator using SCOTT recommended sanitizing or disinfecting cleaner with a sponge or soft cloth.
3. Inspect the inside of the regulator assembly through the regulator opening. See FIGURE 18. If excessive dirt or soil is present, forward regulator assembly to SCOTT trained authorized personnel for thorough cleaning.
4. Depress the donning/air saver switch, close the purge knob by turning fully clockwise. Use the SCOTT recommended sanitizing or disinfecting cleaner in the regulator opening and the immediate area around the opening. See FIGURE 18. Be sure to cover internal components completely.
5. Follow the user instructions for the SCOTT recommended cleaner. A specific contact time may be required for sanitizing or disinfecting before rinsing.
6. Rinse the regulator with drinking water using a spray bottle or gently running tap water.
7. Shake excess water out of regulator. Completely air dry the regulator before use.

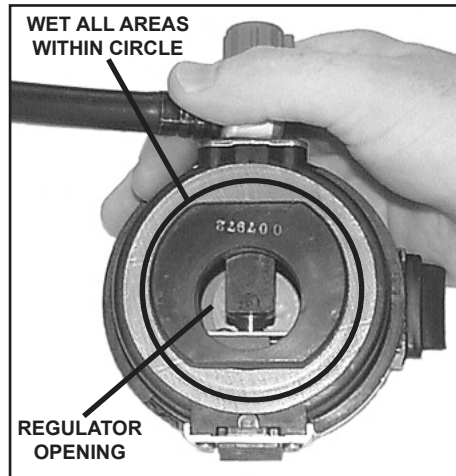

**FIGURE 18**

### **NOTE**

TO SPEED DRYING OF THE REGULATOR, GENTLY BLOW DRY WITH CLEAN, DRY BREATHING AIR OF 30 PSIG MAXIMUM. **DO NOT USE SHOP AIR OR ANY OTHER AIR CONTAINING LUBRICANTS OR MOISTURE.**

8. If regulator was disconnected from air supply for cleaning, reconnect and open purge valve to remove any moisture from regulator spray bar. Close purge valve.
9. Perform **REGULATOR CHECK** as described below.

**CLEANING AND STORAGE  
CONTINUED NEXT PAGE...**

## CLEANING AND STORAGE CONTINUED...

### **REGULATOR CHECK**

#### **NOTE**

THIS REGULATOR CHECK IS NOT INTENDED TO BE A COMPLETE FUNCTIONAL CHECK OF THE RESPIRATOR. **BEFORE NEXT USE, PERFORM A REGULAR OPERATIONAL INSPECTION AS DESCRIBED IN THESE INSTRUCTIONS.**

1. Check to make sure the respirator cylinder is at least 1/4 full.
2. Verify that the donning/air saver switch is fully depressed.
3. Close the purge knob.
4. Reattach the regulator to the respirator, (if removed for cleaning).
5. Slowly open the cylinder valve at least one (1) full turn.
6. If air flow from the regulator is heard, close the cylinder valve, repeat steps 1, 2 and 3. If air flow is still heard, close the cylinder valve fully, tag unit for repair and remove from service.
7. Open the purge valve and observe the air flow from the regulator spray bar. Droplets of water indicate the regulator is not dry. Dry the regulator according to Step 7 of PROCEDURE FOR CLEANING THE MASK MOUNTED REGULATOR section and repeat the REGULATOR CHECK.

#### **WARNING**

**FOLLOW THE REGULAR OPERATIONAL INSPECTION PROCEDURE EXACTLY. IF THE RESPIRATOR DOES NOT OPERATE AS DESCRIBED OR ANY OTHER OPERATIONAL MALFUNCTION IS NOTED, DO NOT USE THE RESPIRATOR. REMOVE IT FROM SERVICE AND TAG FOR REPAIR BY AUTHORIZED PERSONNEL. FAILURE TO PROPERLY INSPECT THE RESPIRATOR MAY RESULT IN SERIOUS INJURY OR DEATH.**

#### **CAUTION**

**OVERTIGHTENING THE CYLINDER VALVE MAY CAUSE DAMAGE THAT COULD RESULT IN LEAKAGE OF AIR FROM THE CYLINDER. USE NO TOOLS TO CLOSE THE CYLINDER VALVE.**

## **STORAGE OF THE RESPIRATOR**

1. Check to ensure gasket is present between facepiece and mask-mounted regulator and is not damaged.
2. Connect the regulator to the facepiece. With the red purge valve in the 12 o'clock position, align the two flats of the outlet port with corresponding flats in the facepiece port and insert. Rotate the regulator counterclockwise (viewed from inside of facepiece) so that the red purge valve knob is situated on the left side of the facepiece. The lock tab on the mask-mounted regulator will lock into the facepiece retainer with a "click." If properly engaged, the regulator will not rotate.
3. To reattach a breathing regulator equipped with a quick disconnect to the respirator. See FIGURE 4.
4. Verify that the respirator is thoroughly dry before placing in storage.
5. Place the clean and dry facepiece in a sealable enclosure to protect until next use. Store in a manner that will not distort the face seals.
6. Place the respirator in the carrying case, protective container, or in a suitable storage location.
7. If any damage or deterioration is noted, remove the respirator from service and tag for repair.
8. Where an SCBA, its spare components or related equipment are stored or carried within a vehicle, such items shall be secured by either a positive mechanical means designed to hold the item in its stowed position, in a compartment with a positive latching door, or in a closed container suitable to transport and contain the SCBA and/or its spare components and associated equipment. The mechanical means of holding the SCBA, its spare components and associated equipment in place, the compartment or the closed container shall be designed to contain the SCBA, its spare components and associated equipment and thereby minimize the possibility of injury to persons in or near the vehicle during movement of the vehicle, especially during rapid deceleration or rapid acceleration of the vehicle, sharp turns or an accident.

### **WARNING**

**PLACING RESPIRATORS IN STORAGE WITHOUT THOROUGHLY DRYING THEM MAY RESULT IN CORROSION OR OTHER DAMAGE WHICH COULD CAUSE A MALFUNCTION OF THE RESPIRATOR. SUCH A MALFUNCTION MAY RESULT IN SERIOUS INJURY OR DEATH.**

### **WARNING**

**PLACING RESPIRATORS IN STORAGE WITHOUT THOROUGHLY DRYING THEM MAY RESULT IN RESIDUAL MOISTURE WHICH MAY FREEZE IN COLD TEMPERATURES AND CAUSE A MALFUNCTION OF THE RESPIRATOR. SUCH A MALFUNCTION MAY RESULT IN SERIOUS INJURY OR DEATH.**

## RESPIRATOR MARKINGS

Do not alter or permanently cover over any labels on the SCOTT AIR-PAK 75i SCBA or SCBA cylinder and valve assembly. ANY user applied identification markings or labels MUST NOT:

- obscure any labels supplied on the SCBA or the SCBA cylinder and valve assembly.
- weaken or damage the SCBA or the SCBA cylinder and valve assembly,
- interfere with the proper function of these assemblies,
- add flammable materials to these assemblies.

## PERIODIC TESTING

SCOTT recommends that this respirator be checked, both visually and functionally, by a SCOTT Authorized Service Center using SCOTT Authorized Test Equipment at least every two years<sup>3</sup>. However, heavy use and/or severe service conditions may require more frequent testing. This recommendation is in addition to all other cleaning and maintenance procedures. The SCOTT *Specialist Level Maintenance Modules* containing additional maintenance information is available on request from SCOTT Health Safety.

In addition to the visual and functional test of the respirator by a SCOTT Authorized Service Center, all air cylinders used with SCOTT respirators must be periodically visually inspected and hydrostatically tested by a licensed cylinder re-tester. The cylinder inspection and test must be done in accordance with the appropriate US Department of Transportation (DOT) specification or the applicable DOT exemption or in accordance with the appropriate Transport Canada (TC) Permit of Equivalent Level of Safety. See step 2 of the REGULAR OPERATIONAL INSPECTION section of this instruction.

Because this respirator may be used to support human life in a hazardous atmosphere, the user should not attempt maintenance beyond that described in this instruction or in the SCOTT *Specialist Level Maintenance Modules*. If disassembly or adjustment other than described in this instruction or the SCOTT *Specialist Level Maintenance Modules* is found to be required, the respirator must be serviced by a SCOTT Authorized Service Facility in accordance with the appropriate SCOTT Service Manuals. Service by a SCOTT Authorized Service Facility can be arranged through your authorized SCOTT Distributor or by contacting SCOTT Safety.

## RETIREMENT CRITERIA AND CONSIDERATIONS

Retirement criteria and considerations to be determined by SCOTT trained and Certified Overhaul Technicians.

## QUESTIONS OR CONCERNS

If you have any questions or concerns regarding use of this equipment, contact your authorized SCOTT distributor, or contact SCOTT at 1-800-247-7257 (or 704-291-8300 outside the continental United States).

## WARNING

APPLYING ANY MARKINGS OR LABELS THAT DAMAGE OR OBSCURE THE EXISTING LABELING MAY VOID THE APPROVAL OF THE CERTIFYING AGENCY BY INTERFERING WITH PROPER IDENTIFICATION OF ASSEMBLIES. IMPROPER IDENTIFICATION OF ASSEMBLIES MAY RESULT IN ERRORS IN MAINTENANCE CAUSING FAILURE OF THE RESPIRATOR WHICH MAY RESULT IN SERIOUS INJURY OR DEATH.

## WARNING

DO NOT APPLY ANY MARKINGS OR LABELS THAT DAMAGE OR INTERFERE WITH THE OPERATION OF THE RESPIRATOR. ANY USER APPLIED MARKINGS THAT INTERFERE WITH THE OPERATION OF THE RESPIRATOR MAY CAUSE A FAILURE OF THE RESPIRATOR AND MAY RESULT IN SERIOUS INJURY OR DEATH.

## WARNING

FAILURE TO REGULARLY INSPECT AND MAINTAIN THIS RESPIRATOR AS INSTRUCTED HEREIN MAY RESULT IN A FAILURE OF THE RESPIRATOR LEADING TO SERIOUS INJURY OR DEATH.

## WARNING

MAINTAIN ONLY WITH APPROVED PARTS AND IN ACCORDANCE WITH APPROVED METHODS. THE USE OF NON-SCOTT AUTHORIZED COMPONENTS DURING MAINTENANCE, OR ATTEMPTING MAINTENANCE BEYOND THE SCOPE OF THIS INSTRUCTION WITHOUT THE PROPER TRAINING, EQUIPMENT, AND AUTHORIZATION MAY RESULT IN A FAILURE OF THE RESPIRATOR LEADING TO SERIOUS INJURY OR DEATH.

<sup>3</sup> For respirators equipped with a breathing regulator with part number either 200077-XX or 200204-XX, inspect the respirator at least once a year.

## OPTIONS AND ACCESSORIES

The SCOTT AIR-PAK **75i** SCBA may be equipped with one or more accessories or options. The user of the respirator must determine which accessories or optional components are installed on the respirator. Become thoroughly familiar with the operation and maintenance of the accessories and options as explained in this instruction and in all other instructions provided with this respirator or the option or accessory. These and other options may be added to a respirator after purchase. Refer to the instructions provided with the accessories or optional components for details of the operation and the required changes to the REGULAR OPERATIONAL INSPECTION.

- SCOTT full facepieces used with the SCOTT AIR-PAK **75i** SCBA are available in a variety of models and sizes.
- Spectacle corrective lens kit.
- Quick Disconnect on the mask mounted breathing regulator.
- PASS device distress alarm (Personal Alert Safety System) which monitors the motion of a respirator user and emits an audible signal when the user has not moved for a period of time.
- Various communications devices are also available.

The accessories listed below are approved by NIOSH for use with SCOTT AIR-PAK **75i** models 2.2 / 4.5 respirators.

1. A variety of Lens Kits are available to allow installation of corrective lenses in facepiece.
2. Neck Strap, P/N 804088-01, is used to hold facepiece in a ready position.
3. Hard carrying case, P/N 804497-01, and soft carrying case, P/N 10009324, are used to store and transport respirator.
4. Gauge Protector Kit, P/N 10008500, provides the remote reading pressure gauge with protection from impact and abrasion.
5. Facepiece assemblies for the respirator are available in a variety of sizes and styles. See your authorized SCOTT distributor for details.
6. Clear protective Lens Cover, P/N 803941-25 (package of 25), is used to protect full facepiece lens against external scratching, spatter, paint spray and abrasion.
7. Regulator Holder, P/N 10008880, attaches to the waist belt to conveniently keep the E-Z Flo Regulator secure and clean when not in use.
8. Shoulder & Hip Pad Kit, P/N 803810-01, attaches to and provides maximum comfort for user of Back-Pak assembly P/N 804173-01.
9. Weld-O-Vista Welding Kit, 805438-SERIES, is designed to provide vision protection for welders using AIR-PAK **75i** respirators.
10. Refer to the FACEPIECE FITTING AND FIT TESTING section of this instruction for information about Fit Testing Accessories. Consult your SCOTT distributor for details of availability and application.

### WARNING

THE USER OF THIS RESPIRATOR MUST RECEIVE TRAINING IN THE OPERATION OF THE RESPIRATOR INCLUDING THE OPERATION OF ALL OPTIONS AND/OR ACCESSORIES INCORPORATED IN THE RESPIRATOR. SEE WARNING AT THE BEGINNING OF PAGE TWO OF THIS INSTRUCTION.

### WARNING

ONLY THOSE OPTIONS AND/OR ACCESSORIES AUTHORIZED BY SCOTT AND APPROVED BY NIOSH MAY BE INSTALLED IN THIS RESPIRATOR. THE USE OF UNAUTHORIZED AND/OR UNAPPROVED OPTIONS OR ACCESSORIES COULD CAUSE PARTIAL OR COMPLETE FAILURE OF THE RESPIRATOR WHICH MAY RESULT IN INJURY OR DEATH.

## BATTERY REPLACEMENT

When the optional Heads-up Display or PASS device are installed, batteries are required for the proper operation of the equipment. Instructions for battery replacement on optional AIR-PAK respirator features are contained in this instruction. Certain accessories and features require batteries for operation. Refer to the user instructions provided with any approved communications device for details of operation and maintenance. Always verify that this equipment and all accessories used with it have fresh batteries before use. Refer to the Operation and Maintenance instructions provided with any other accessories for details of battery replacement.

### RESPIRATORS WITH HEADS-UP DISPLAY ONLY

AIR-PAK respirators equipped with a Heads-Up Display but **NO** PASS device, require two (2) AA batteries in the remote gauge console for operation. The batteries should be replaced only by a trained maintenance technician in a clean area known to be nonflammable.

Replace batteries as follows:

1. Locate the remote gauge console.
2. Using a Phillips driver, remove both battery caps holding the battery cover. See FIGURE 24.

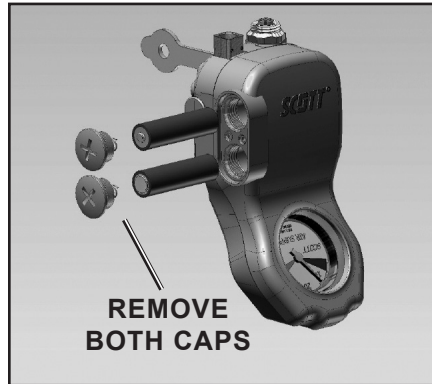

FIGURE 24

3. Slide the two batteries out of the battery compartment.
4. To maintain Intrinsic Safety, replace batteries only with a pair of the following 1.5 volt AA batteries:
  - Eveready<sup>3</sup> Energizer Alkaline EN91
  - Eveready Energizer Alkaline E91.
  - Duracell<sup>4</sup> Alkaline MN1500
  - Duracell Alkaline MX1500
  - Duracell Alkaline PC1500

**Do not mix batteries.** Be sure batteries are properly oriented in battery compartment with the "+" end and the "-" end of each as shown in FIGURE 25.

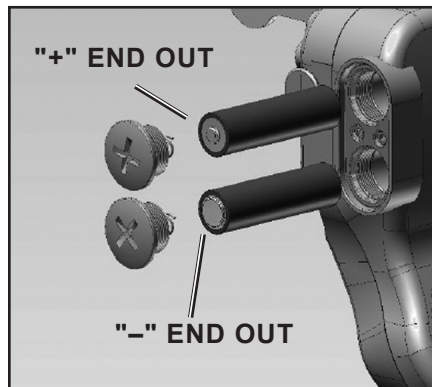

FIGURE 25

5. The battery caps must be installed so that they are water tight after replacement. Clean the inside edge of each battery compartment and seal around the outside of each cover by wiping with a clean damp cloth to remove any dirt or foreign matter which might prevent a proper seal. Check cover gaskets for tears or cuts. If damage is found, remove respirator from service and tag for repair by authorized personnel.
6. When covers are placed in position and the batteries are properly installed, all lights in the HEADS-UP DISPLAY will light for approximately twenty (20) seconds to verify operation.
7. Thread the battery covers in until the edge of the battery cover is touching the face of the battery compartment. Tighten each screw **HAND TIGHT** only. **DO NOT OVERTIGHTEN.** Perform the **REGULAR OPERATIONAL INSPECTION** to verify proper operation of the HEADS-UP DISPLAY.

<sup>3</sup> Energizer is a registered trademark of Eveready Battery Company, Inc., St Louis, MO.

<sup>4</sup> Duracell is a registered trademark of The Procter & Gamble Company, Cincinnati, OH.

## WARNING

**BATTERIES ARE REQUIRED FOR PROPER OPERATION OF THIS EQUIPMENT. FAILURE TO INSTALL BATTERIES AND TO PERFORM A REGULAR OPERATIONAL INSPECTION MAY RESULT IN A MALFUNCTION OF THE EQUIPMENT WHICH COULD RESULT IN SERIOUS INJURY OR DEATH.**

## WARNING

**IF A RESPIRATOR INCORPORATING THE HEADS-UP DISPLAY ONLY IS USED IN AN EXPLOSIVE OR FLAMMABLE ATMOSPHERE, REGULARLY INSPECT THE RESPIRATOR, INCLUDING THE HEADS-UP DISPLAY, AS DESCRIBED IN THIS INSTRUCTION AND CORRECT ANY DAMAGE FOUND. DO NOT SUBSTITUTE ANY PARTS OR COMPONENTS. USE ONLY THE BATTERIES AS SPECIFIED IN THIS INSTRUCTION. THE FAILURE TO CORRECT ANY DAMAGE, THE INSTALLATION OF INCORRECT BATTERIES, OR THE SUBSTITUTION OF ANY OTHER COMPONENTS MAY IMPAIR THE INTRINSIC SAFETY OF THE UNIT AND MAY LEAD TO A FIRE OR AN EXPLOSION WHICH COULD RESULT IN SERIOUS INJURY OR DEATH.**

## WARNING

**BATTERIES MUST ONLY BE CHANGED IN AN AREA KNOWN TO BE NONFLAMMABLE. CHANGING THE BATTERIES IN A FLAMMABLE ATMOSPHERE MAY CAUSE AN IGNITION WHICH COULD RESULT IN SERIOUS INJURY OR DEATH.**

## WARNING

**TO REDUCE THE RISK OF EXPLOSION USE BATTERIES ONLY FROM THE LIST PROVIDED, DO NOT MIX OLD BATTERIES WITH UNUSED BATTERIES, AND DO NOT MIX BATTERIES FROM DIFFERENT MANUFACTURERS. UNAUTHORIZED SUBSTITUTION OF COMPONENTS MAY IMPAIR INTRINSIC SAFETY AND CAUSE AN EXPLOSION WHICH COULD LEAD TO SERIOUS INJURY OR DEATH.**



## RESPIRATORS WITH PAK ALERT SE 7 DISTRESS ALARM

AIR-PAK respirators equipped with a Heads-Up Display AND a PAK ALERT SE 7 distress alarm, require six (6) “AA” cell batteries for operation. The six (6) batteries power both the Heads-Up Display AND the PASS device, so separate batteries in the Gauge Console are not required. The batteries should be replaced only by a trained maintenance technician in a clean area known to be nonflammable. Replace batteries as follows:

1. Close respirator cylinder valve, open regulator purge valve letting out all the trapped air, close regulator purge valve, press the reset button twice. A fifteen second beep sequence occurs as the residual air bleeds off. Unit will sound a two tone chirp and green light will go out.

### NOTE

ALWAYS BE SURE THAT CYLINDER VALVE IS OFF AND THE PASS DEVICE IS COMPLETELY INACTIVE BEFORE CHANGING BATTERIES. NEVER REMOVE OR REPLACE BATTERIES WITH SYSTEM PRESSURIZED OR DAMAGE MAY OCCUR TO ELECTRONIC COMPONENTS.

2. When replacing batteries on respirators, remove the cylinder and place the respirator in a clean, non-hazardous area.
3. Use a Phillips driver to remove the Battery Housing Cover as shown

in FIGURE 26. Carefully remove the cover and set aside.

4. Remove used batteries from battery compartment by sliding them out of the battery compartment.



FIGURE 26

5. Install six (6) fresh new “AA” batteries of the same type. **Always replace all batteries at the same time.** The battery holder is marked with the style and orientation of the batteries required. See FIGURE 27. To maintain Intrinsic Safety, use six (6) each of one of the following 1.5 volt AA batteries:
  - Duracell Alkaline MN1500
  - Duracell Alkaline MX1500
  - Duracell Alkaline PC1500
  - Eveready Energizer Alkaline EN91
  - Eveready Energizer Alkaline E91.

**Do not mix batteries.** Verify correct orientation of batteries as shown on label inside the battery holder.

6. The battery cover must be installed so that it is water tight after replacement. Clean the sealing rib around battery compartment and sealing face of the cover, shown in FIGURE 27, by wiping with a clean damp to remove any dirt or foreign matter which might prevent a proper seal. Check cover gasket for tears or cuts. If damage is found, remove respirator from service and tag for repair by authorized personnel.



FIGURE 27

7. Install battery cover and tighten the cover screw until snug. **AFTER REPLACEMENT OF BATTERIES, PERFORM A REGULAR OPERATIONAL INSPECTION BEFORE RETURNING RESPIRATOR TO SERVICE.**

### CAUTION

SYSTEM MUST NOT BE PRESSURIZED WHEN BATTERIES ARE INSTALLED. DAMAGE TO THE ELECTRONIC COMPONENTS MAY RESULT IF BATTERIES ARE INSTALLED WITH SYSTEM PRESSURIZED.

### CAUTION

OVERTIGHTENING THE CYLINDER VALVE MAY CAUSE DAMAGE THAT COULD RESULT IN LEAKAGE OF AIR FROM THE CYLINDER. USE NO TOOLS TO CLOSE THE CYLINDER VALVE.

### WARNING

THE PAK-ALERT SE 7 DISTRESS ALARM IS INTENDED TO ASSIST IN LOCATING A PERSON WHO MAY BE IN A LIFE THREATENING SITUATION. FAILURE TO FOLLOW THE INSTRUCTIONS FOR OPENING, CHANGING THE BATTERIES AND RE-CLOSING THE BATTERY COMPARTMENT MAY RESULT IN DAMAGE WHICH COULD CAUSE FAILURE OF THE PASS DURING A LIFE THREATENING EMERGENCY OR COULD CAUSE A FIRE OR EXPLOSION IN A FLAMMABLE OR EXPLOSIVE ATMOSPHERE POSSIBLY RESULTING IN INJURY OR DEATH.

### WARNING

BATTERIES MUST ONLY BE CHANGED IN AN AREA KNOWN TO BE NONFLAMMABLE. CHANGING THE BATTERIES IN A FLAMMABLE ATMOSPHERE MAY CAUSE AN IGNITION WHICH COULD RESULT IN SERIOUS INJURY OR DEATH.

### WARNING

TO REDUCE THE RISK OF EXPLOSION USE BATTERIES ONLY FROM THE LIST PROVIDED, DO NOT MIX OLD BATTERIES WITH UNUSED BATTERIES, AND DO NOT MIX BATTERIES FROM DIFFERENT MANUFACTURERS. UNAUTHORIZED SUBSTITUTION OF COMPONENTS MAY IMPAIR INTRINSIC SAFETY AND CAUSE AN EXPLOSION WHICH COULD LEAD TO SERIOUS INJURY OR DEATH.

### CHECK YOUR WORK!

BEFORE ASSEMBLY OF BATTERY COVER, CHECK TO SEE BOTH BATTERIES ARE FRESH, NEW BATTERIES OF THE TYPE INDICATED ABOVE AND THAT THEY HAVE BEEN INSTALLED PROPERLY.

## **WARNING**

**IMPROPER USE OF A RESPIRATOR MAY RESULT IN PERSONAL INJURY OR DEATH. IMPROPER USE INCLUDES, BUT IS NOT LIMITED TO, USE WITHOUT TRAINING, DISREGARD OF THE WARNINGS AND INSTRUCTIONS SUPPLIED WITH THE RESPIRATOR AND ITS ACCESSORIES AND FAILURE TO INSPECT AND MAINTAIN THE RESPIRATOR. READ AND UNDERSTAND THE INSTRUCTION MANUAL AND ANY APPLICABLE ACCESSORY INSTRUCTIONS AND WARNINGS BEFORE ATTEMPTING TO USE A RESPIRATOR**

## **CAUTIONS AND LIMITATIONS**

- D – AIRLINE RESPIRATORS CAN BE USED ONLY WHEN THE RESPIRATORS ARE SUPPLIED WITH RESPIRABLE AIR MEETING THE REQUIREMENTS OF CGA G-7.1 GRADE D OR HIGHER QUALITY.
- E – USE ONLY THE PRESSURE RANGES AND HOSE LENGTHS SPECIFIED IN THE USER'S INSTRUCTIONS.
- I – CONTAINS ELECTRICAL PARTS WHICH HAVE NOT BEEN EVALUATED AS AN IGNITION SOURCE IN FLAMMABLE OR EXPLOSIVE ATMOSPHERES BY MSHA/NIOSH.
- J – FAILURE TO PROPERLY USE AND MAINTAIN THIS PRODUCT COULD RESULT IN INJURY OR DEATH.
- M – ALL APPROVED RESPIRATORS SHALL BE SELECTED FITTED, USED AND MAINTAINED IN ACCORDANCE WITH MSHA, OSHA AND OTHER APPLICABLE REGULATIONS.
- N – NEVER SUBSTITUTE, MODIFY, ADD OR OMIT PARTS. USE ONLY EXACT REPLACEMENT PARTS IN THE CONFIGURATION AS SPECIFIED BY THE MANUFACTURER.
- O – REFER TO USER'S INSTRUCTIONS AND/OR MAINTENANCE MANUALS FOR INFORMATION ON USE AND MAINTENANCE OF THESE RESPIRATORS.
- S – SPECIAL OR CRITICAL USER'S INSTRUCTIONS AND/OR SPECIFIC USE LIMITATIONS APPLY. REFER TO INSTRUCTION MANUAL BEFORE DONNING.

## **S—SPECIAL OR CRITICAL USER'S INSTRUCTIONS**

ALL MODELS ARE APPROVED ONLY WHEN COMPRESSED AIR CYLINDER IS FULLY CHARGED WITH AIR MEETING THE REQUIREMENTS OF THE COMPRESSED GAS ASSOCIATION SPECIFICATION G-7.1, GRADE D AIR OR EQUIVALENT SPECIFICATIONS, OR MEETING CE EUROPEAN STANDARD EN 132. THE CONTAINER SHALL MEET APPLICABLE DOT SPECIFICATIONS.

EXCEPT AS NOTED HEREIN, ALL MODELS OF THE SCOTT 2.2 OR 4.5 ARE APPROVED FOR RESPIRATORY PROTECTION DURING ENTRY INTO OR ESCAPE FROM OXYGEN DEFICIENT ATMOSPHERES, GASES AND VAPORS, AT TEMPERATURES ABOVE -25° F / -32° C.

MASK SEAL KIT P/N 805655-01 IS REQUIRED IF A USER SEAL CHECK IS UNSATISFACTORY EITHER PER THE USER INSTRUCTIONS OR THE OSHA FIT TESTING PROCESS. THE MASK SEAL KIT IS PROVIDED WITH THE FULL FACEPIECE. THIS IS A NIOSH APPROVED COMPONENT TO ENHANCE THE FIT OF THE FACEPIECE.

WHEN USING FACEPIECE P/N 803921-01, 803921-02, OR 803921-03 AT TEMPERATURES BELOW 32° F / 0° C, USE THE OPTIONAL NOSE CUP ASSEMBLY P/N 802819-01.

THE SCOTT COMMUNICATIONS DEVICES CAN ONLY BE USED WITH SCOTT FACEPIECES FITTED WITH DUAL VOICEMITTERS SUCH AS THE AV-2000 OR AV-3000.

# WARRANTY

---

## SCOTT SAFETY

### LIMITED WARRANTY ON AIR-PAK 2.2/3.0/4.5 and AIR-PAK 75 PRODUCTS

Scott Safety (SCOTT) warrants AIR-PAK 2.2/3.0/4.5 and AIR-PAK 75 PRODUCTS (THE PRODUCTS) to be free from defects in workmanship and materials for a period of ten (10) years from the date of original manufacture by SCOTT. This warranty applies to all components of THE PRODUCTS including all accessories and optional equipment purchased and supplied at the time of original sale of THE PRODUCTS, EXCEPT pressure reducers, electrically operated devices, consumable supplies and carrying cases. SCOTT warrants all pressure reducers supplied with THE PRODUCTS to be free from defects in workmanship and materials for a period of fifteen (15) years from the date of original manufacture by SCOTT. SCOTT warrants all electrically operated devices supplied with THE PRODUCTS to be free from defects in workmanship and materials for three (3) years from the date of original manufacture by SCOTT. SCOTT further warrants all communications devices, unused consumable supplies, and carrying cases supplied with THE PRODUCTS to be free from defects in workmanship and materials for one (1) year from the date of original manufacture by SCOTT. SCOTT's obligation under this warranty is limited to replacing or repairing (at SCOTT's option) THE PRODUCTS or components shown to be defective in either workmanship or materials.

Only personnel of SCOTT or, when directed by SCOTT, authorized SCOTT agents are authorized to perform warranty obligations. This warranty does not apply to defects or damage caused by any repairs of or alterations to THE PRODUCTS made by owner or any third party unless expressly permitted by SCOTT product manuals or by written authorization from SCOTT. To obtain performance under this warranty, and as a condition precedent to any duty of SCOTT, the purchaser must return such products to SCOTT, a SCOTT authorized distributor or a SCOTT authorized service center. Any product returned to SCOTT shall be sent to "SCOTT SAFETY" (Attn: Warranty Claim Dept.), P.O. Box 569, Monroe, NC 28111.

This warranty does not apply to any malfunction of or damage to THE PRODUCTS resulting from accident, alteration, misuse or abuse.

THIS WARRANTY IS MADE IN LIEU OF ALL OTHER WARRANTIES, EXPRESSED OR IMPLIED INCLUDING, BUT NOT LIMITED TO, ANY IMPLIED WARRANTY OF MERCHANTABILITY OR FITNESS FOR A PARTICULAR PURPOSE. IN ADDITION, SCOTT EXPRESSLY DISCLAIMS ANY LIABILITY FOR SPECIAL, INCIDENTAL OR CONSEQUENTIAL DAMAGES IN ANY WAY CONNECTED WITH THE SALE OR USE OF SCOTT SAFETY PRODUCTS, AND NO OTHER FIRM OR PERSON IS AUTHORIZED TO ASSUME ANY SUCH LIABILITY.



*A Tyco International Company*

SCOTT Safety Products  
Monroe Corporate Center  
PO Box 569  
Monroe, NC 28111  
Telephone 1-800-247-7257  
FAX (704) 291-8330  
[www.scottsafety.com](http://www.scottsafety.com)

**Scott Safety**  
ISO 9001 REGISTERED

Printed in USA