

mitsubishi

MODEL GT15V-75ROUT

RGB Output Unit

User's Manual

Thank you for purchasing the GOT1000 Series.

Prior to use, please read both this manual and detailed manual thoroughly to fully understand the product.

MODEL	GT15V-75ROUT-U
MODEL CODE	1D7M55
IB(NA)-0800349-F(1111)MEE	

GRAPHIC OPERATION TERMINAL

GOT1000

●SAFETY PRECAUTIONS●

(Always read these precautions before using this equipment.)

Before using this product, please read this manual and the relevant manuals introduced in this manual carefully and pay full attention to safety to handle the product correctly.

The precautions given in this manual are concerned with this product.

In this manual, the safety precautions are ranked as "DANGER" and "CAUTION".



DANGER

Indicates that incorrect handling may cause hazardous conditions, resulting in death or severe injury.



CAUTION

Indicates that incorrect handling may cause hazardous conditions, resulting in medium or slight personal injury or physical damage.

Note that the  caution level may lead to a serious accident according to the circumstances. Always follow the instructions of both levels because they are important to personal safety.

Please save this manual to make it accessible when required and always forward it to the end user.

[DESIGN PRECAUTIONS]

CAUTION

- Do not bunch the control wires or communication cables with the main circuit or power wires, or lay them close to each other.
As a guide, separate the lines by a distance of at least 100mm (3.94 inches) otherwise malfunctions may occur due to noise.

[MOUNTING PRECAUTIONS]

DANGER

- Be sure to shut off all phases of the external power supply used by the system before mounting or removing this unit onto/from the GOT.
Not doing so can cause the unit to fail or malfunction.

CAUTION

- Use this unit in the environment that satisfies the general specifications described in the User's Manual for the GOT used.
Not doing so can cause an electric shock, fire, malfunction or product damage or deterioration.
- Tighten the mounting screws within the specified torque range.
Undertightening can cause the GOT to drop, short circuit or malfunction.
Overtightening can cause a drop, short circuit or malfunction due to the damage of the screws or the GOT.
- Do not touch the conductive and electronic parts of the unit directly.
Doing so can cause a unit malfunction or failure.

[WIRING PRECAUTIONS]

DANGER

- Be sure to shut off all phases of the external power supply used by the system before wiring.
Failure to do so may result in an electric shock, product damage or malfunctions.

CAUTION

- Exercise care to avoid foreign matter such as chips and wire offcuts entering the GOT. Not doing so can cause a fire, failure or malfunction.
- Make sure to securely connect the cable to the connector of unit.
Incorrect connection may cause malfunctions.
- Do not hold the cable by hand and pull it out from the unit.
When removing the cable from the unit, make sure to hold the connector by hand and pull it.
Failure to do so may cause malfunctions or damage to the unit or cable.

[STARTUP/MAINTENANCE PRECAUTIONS]

DANGER

- When power is on, do not touch the terminals.
Doing so can cause an electric shock or malfunction.
- Before starting cleaning, always shut off GOT power externally in all phases.
Not doing so can cause a unit failure or malfunction.
Undertightening can cause a short circuit or malfunction.
Overtightening can cause a short circuit or malfunction due to the damage of the screws or unit.

CAUTION

- Do not disassemble or modify the unit.
Doing so can cause a failure, malfunction, injury or fire.
- Do not drop the module or subject it to strong shock.
A module damage may result.
- Before touching the unit, always touch grounded metal, etc. to discharge static electricity from human body, etc.
Not doing so can cause the unit to fail or malfunction.

[DISPOSAL PRECAUTIONS]

CAUTION

- When disposing of the product, handle it as industrial waste.

[TRANSPORTATION PRECAUTIONS]

CAUTION

- Make sure to transport the GOT main unit and/or relevant unit(s) in the manner they will not be exposed to the impact exceeding the impact resistance described in the general specifications of the User's Manual for the GOT used, as they are precision devices.
Failure to do so may cause the unit to fail.
Check if the unit operates correctly after transportation.

REVISIONS

* The manual number is noted at the lower right of the top cover.

Print Date	*Manual Number	Revision
Mar., 2006	IB(NA)-0800349-A	First edition
Feb., 2007	IB(NA)-0800349-B	<p>Partial addition</p> <p>Chapter 1</p> <p>Addition</p> <p>Compliance with the EMC and Low Voltage Directives</p>
Jul., 2007	IB(NA)-0800349-C	<p>Partial corrections</p> <p>Compliance with the EMC and Low Voltage Directives, Chapter 2, 3, 4</p>
Jun., 2009	IB(NA)-0800349-D	<p>Partial corrections</p> <p>Compliance with the EMC and Low Voltage Directives</p>
Jun., 2011	IB(NA)-0800349-E	<p>Addition</p> <p>Compliance with the Radio Waves Act (South Korea)</p>
Nov., 2011	IB(NA)-0800349-F	<p>Partial corrections</p> <p>Chapter 2</p>

This manual confers no industrial property rights or any rights of any other kind, nor does it confer any patent licenses. Mitsubishi Electric Corporation cannot be held responsible for any problems involving industrial property rights which may occur as a result of using the contents noted in this manual.

© 2006 MITSUBISHI ELECTRIC CORPORATION

CONTENTS

1. OVERVIEW	1
2. SPECIFICATIONS	2
2.1 RGB output unit	2
2.2 Specifications of the cables (9-core combined cables) used when connecting the external display	3
3. PART NAMES AND EXTERNAL DIMENSIONS	4
4. INSTALLATION PROCEDURE	6

Manuals

The following shows manuals relevant to this product.

Detailed Manual

Manual name	Manual number (Model code)
GT15 User's Manual (Sold separately)	SH-080528ENG (1D7M23)
GOT1000 Series Connection Manual (Microcomputer, MODBUS Products, Peripherals) for GT Works3 (Sold separately)	SH-080871ENG (1D7MC5)

Relevant Manuals

For relevant manuals, refer to the PDF manuals stored in the CD-ROM for the drawing software used.

Packing List

The following items are included.

Model	Product	Quantity
GT15V-75ROUT	RGB output unit	1
	Mounting screw set (2 screws, 2 stickers)	2
	Extend interface relay board	1

Compliance with the EMC and Low Voltage Directives

To configure a system meeting the requirements of the EMC and Low Voltage Directives when incorporating the Mitsubishi GOT (EMC and Low Voltage Directives compliant) into other machinery or equipment, refer to "EMC AND LOW VOLTAGE DIRECTIVES" of the General Description included with the GOT used.

The CE mark, indicating compliance with the EMC and Low Voltage Directives, is printed on the rating plate of the GOT.

Compliance with the Radio Waves Act (South Korea)

This product complies with the Radio Waves Act (South Korea).

Note the following when using the product in South Korea.

이 기기는 업무용 (A 급) 전자파적합기기로서 판매자 또는 사용자는 이 점을 주의하시기 바라며, 가정외의 지역에서 사용하는 것을 목적으로 합니다.

(The product is for business use (Class A) and meets the electromagnetic compatibility requirements.

The seller and the user must note the above point, and use the product in a place except for home.)

1. OVERVIEW

This User's Manual describes the GT15V-75ROUT RGB output unit (hereinafter referred to as the RGB output unit).

When mounting RGB output unit with GT1585V-STBA and GT1575V-STBA, (hereinafter collectively referred to as the GOT), the RGB output unit can external display screens on GOT.

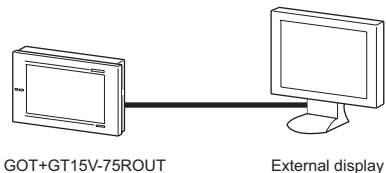

To use the RGB output unit, make the Communication Settings.

For setting details, refer to GOT1000 Series Connection Manual (Microcomputer, MODBUS Products, Peripherals) for GT Works3.

For details of system configuration, refer to GOT1000 Series Connection Manual (Microcomputer, MODBUS Products, Peripherals) for GT Works3.

2. SPECIFICATIONS

2.1 RGB output unit

Item		Specifications		
RGB input section	RGB output method (dot's)	Analog RGB(SVGA; 800x600)		
	Number of RGB output channels	1 channel		
	Dot clock	38.362 MHz		
	Horizontal scanning frequency	37.87 kHz		
	Vertical scanning frequency	60.30 Hz		
	Timing chart	Horizontal synchronizing timing	Vertical synchronizing timing	
	RGB external connection method	D-Sub15 pin		
Applicable wire size	9-core combined cable (recommended)			
Internal current consumption (5VDC)	0.11 A			
Weight	0.16 kg (0.35 lb)			

2.2 Specifications of the cables (9-core combined cables) used when connecting the external display

(1) Cable specifications

Item	Specifications
Applicable connector	15-pin D-sub for both ends

(2) Connection diagram

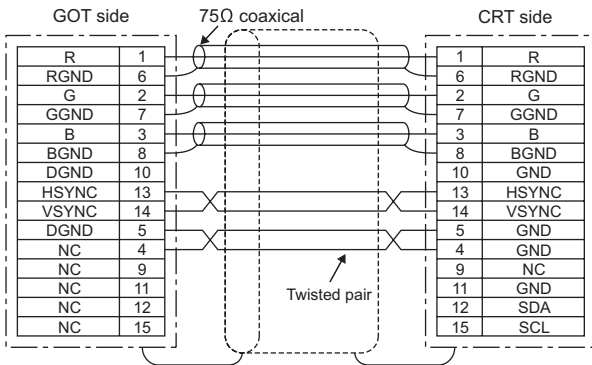

(3) Connector

- GOT connector
Use the connector matching the following model for the GOT.
15-pin D-sub (male) inch screw type
Manufactured by DDK
17HE-R13150-73MC2
- Connector at the display
Use the connector applicable to the display.

3. PART NAMES AND EXTERNAL DIMENSIONS

(1) Part names and external dimensions of the RGB output unit

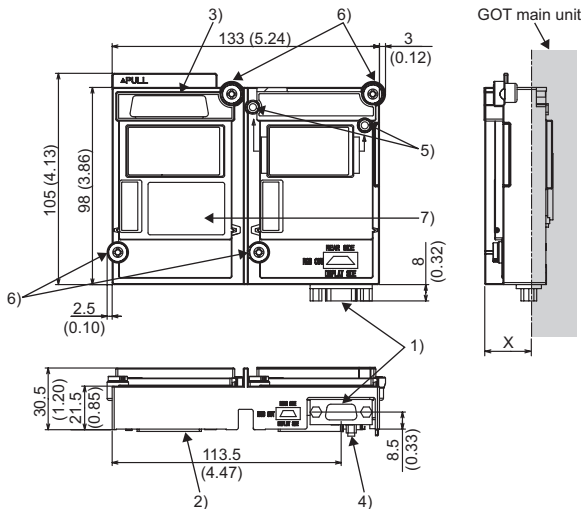

Dimensions of X when the RGB output unit is mounted to the GOT.

12.1"	18 (0.71)
10.4"	21 (0.83)

Unit: mm (inch)

No.	Name	Description
1)	Connector for RGB output	Connector for connecting a 9-core combined cable
2)	Interface connector	Connector mounted to the GOT
3)	Extension connector	Connector to which a back extension unit is installed
4)	Connector for video/RGB connection	Connector connecting with the video/RGB interface of GOT
5)	Board fixing screw	Screw for fixing the extend interface relay board
6)	Mounting screw	Mounting screws for fixing the unit to the GOT
7)	Rating plate	-

(2) Extend interface relay board

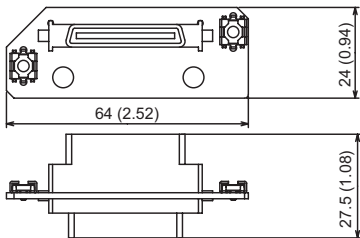

Unit: mm (inch)

4. INSTALLATION PROCEDURE

The installation procedure for the RGB output unit is explained using the GT1575.

- (1) Power off the GOT.
- (2) Remove two extension unit covers of the GOT.

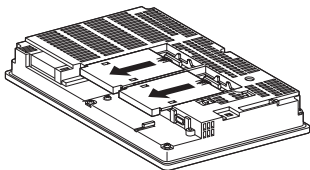

- (3) Attach the extend interface relay board to the extend I/F-2 side on the GOT.
After the installation, detach the connector cover from the extend interface relay board.

- (4) Fit the RGB output unit in the GOT case.

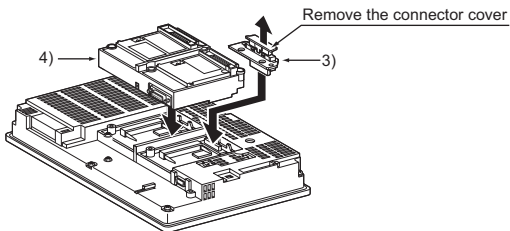

- (5) Fasten the RGB output unit by tightening its mounting screws (4 places) with tightening torque 0.36 to 0.48 N·m.

- (6) Fasten the bus connection unit by tightening the board fixing screws (2 places) with the tightening torque of 0.36 to 0.48 N•m.

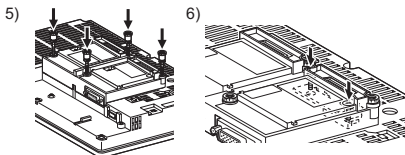

- (7) When installing an extension unit on the unit that has been installed, remove the connector cover and the sticker. When not installing an extension unit on the unit that has been installed, in order to avoid receiving electrostatic, stick accessory stickers to cover the top of mounting screws (4 places). Keep the connector cover fixed. Keep the sticker stuck as it is.

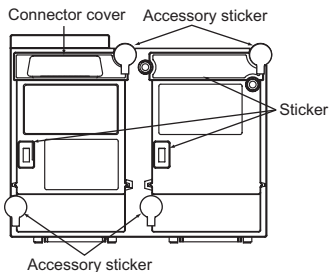

Point

Remove the screws that fixes the extend interface relay board before removing the unit.(Above 6))

Warranty

Mitsubishi will not be held liable for damage caused by factors found not to be the cause of Mitsubishi; machine damage or lost profits caused by faults in the Mitsubishi products; damage, secondary damage, accident compensation caused by special factors unpredictable by Mitsubishi; damages to products other than Mitsubishi products; and to other duties.

For safe use

- This product has been manufactured as a general-purpose part for general industries, and has not been designed or manufactured to be incorporated in a device or system used in purposes related to human life.
- Before using the product for special purposes such as nuclear power, electric power, aerospace, medicine or passenger movement vehicles, consult with Mitsubishi.
- This product has been manufactured under strict quality control. However, when installing the product where major accidents or losses could occur if the product fails, install appropriate backup or failsafe functions in the system.

Country/Region	Sales office/Tel	Country/Region	Sales office/Tel
U.S.A	Mitsubishi Electric Automation Inc. 500 Corporate Woods Parkway Vernon Hills, IL 60061, U.S.A. Tel : +1-847-478-2100	Hong Kong	Mitsubishi Electric Automation (Hong Kong) Ltd. 10th Floor, Manulife Tower, 169 Electric Road, North Point, Hong Kong Tel : +852-2887-8870
Brazil	MELCO-TEC Rep. Com.e Assessoria Tecnica Ltda. Rua Correia Dias, 184, Edificio Paraíso Trade Center-8 andar Paraíso, Sao Paulo, SP Brazil Tel : +55-11-5908-8331	China	Mitsubishi Electric Automation (China) Ltd. 4/F Zhi Fu Plaza, No.80 Xin Chang Road, Shanghai 200003, China Tel : +86-21-6120-0808
Germany	Mitsubishi Electric Europe B.V. German Branch Gothaer Strasse 8 D-40880 Ratingen, GERMANY Tel : +49-2102-486-0	Taiwan	Setsuyo Enterprise Co., Ltd. 6F No.105 Wu-Kung 3rd.Rd, Wu-Ku Hsiang, Taipei Hsine, Taiwan Tel : +886-2-2299-2499
U.K	Mitsubishi Electric Europe B.V. UK Branch Travellers Lane, Hatfield, Hertfordshire., AL10 8XB, U.K. Tel : +44-1707-276100	Korea	Mitsubishi Electric Automation Korea Co., Ltd. 1480-6, Gayang-dong, Gangseo-ku Seoul 157-200, Korea Tel : +82-2-3660-9552
Italy	Mitsubishi Electric Europe B.V. Italian Branch Centro Dir. Colleoni, Pal. Perseo-Ingr.2 Via Paracelso 12, I-20041 Agrate Brianza., Milano, Italy Tel : +39-039-60531	Singapore	Mitsubishi Electric Asia Pte, Ltd. 307 Alexandra Road #05-01/02, Mitsubishi Electric Building, Singapore 159943 Tel : +65-6470-2460
Spain	Mitsubishi Electric Europe B.V. Spanish Branch Carretera de Rubi 76-80, E-08190 Sant Cugat del Valles, Barcelona, Spain Tel : +34-93-565-3131	Thailand	Mitsubishi Electric Automation (Thailand) Co., Ltd. Bang-Chan Industrial Estate No.11 Moo 4, Serithai Rd, T.Kannayao, A.Kannayao, Bangkok 10230 Thailand Tel : +66-2-517-1326
France	Mitsubishi Electric Europe B.V. French Branch 25, Boulevard des Bouvets, F-92741 Nanterre Cedex, France Tel : +33-1-5568-5568	Indonesia	P.T. Autoteknindo Sumber Makmur Muara Karang Selatan, Block A/Utara No.1 Kav. No.11 Kawasan Industri Pergudangan Jakarta - Utara 14440, P.O.Box 5045 Jakarta, 11050 Indonesia Tel : +62-21-6630833
South Africa	Circuit Breaker Industries Ltd. Private Bag 2016, ZA-1600 Isando, South Africa Tel : +27-11-928-2000	India	Messung Systems Pvt. Ltd. Electronic Sadan NO:III Unit No15, M.I.D.C Bhosari, Pune-411026, India Tel : +91-20-2712-3130
		Australia	Mitsubishi Electric Australia Pty. Ltd. 348 Victoria Road, Rydalmere, N.S.W 2116, Australia Tel : +61-2-9684-7777

MITSUBISHI ELECTRIC CORPORATION

HEAD OFFICE : TOKYO BUILDING, 2-7-3 MARUNOUCHI, CHIYODA-KU, TOKYO 100-8310, JAPAN
NAGOYA WORKS : 1-14, YADA-MINAMI 5-CHOME, HIGASHI-KU, NAGOYA, JAPAN

When exported from Japan, this manual does not require application to the Ministry of Economy, Trade and Industry for service transaction permission.

Specifications subject to change without notice.
Printed in Japan, November 2011.