



RHINO-RACK

Rhino-Rack S-Loader (RUSL)

Important: Please read these instructions carefully prior to installation. Please refer to your fitting instruction to ensure that the bike rack is installed in the correct locations. Check the contents of kit before commencing fitment and report any discrepancies. Place these instructions in the vehicle's glove box after installation is complete.

Layout

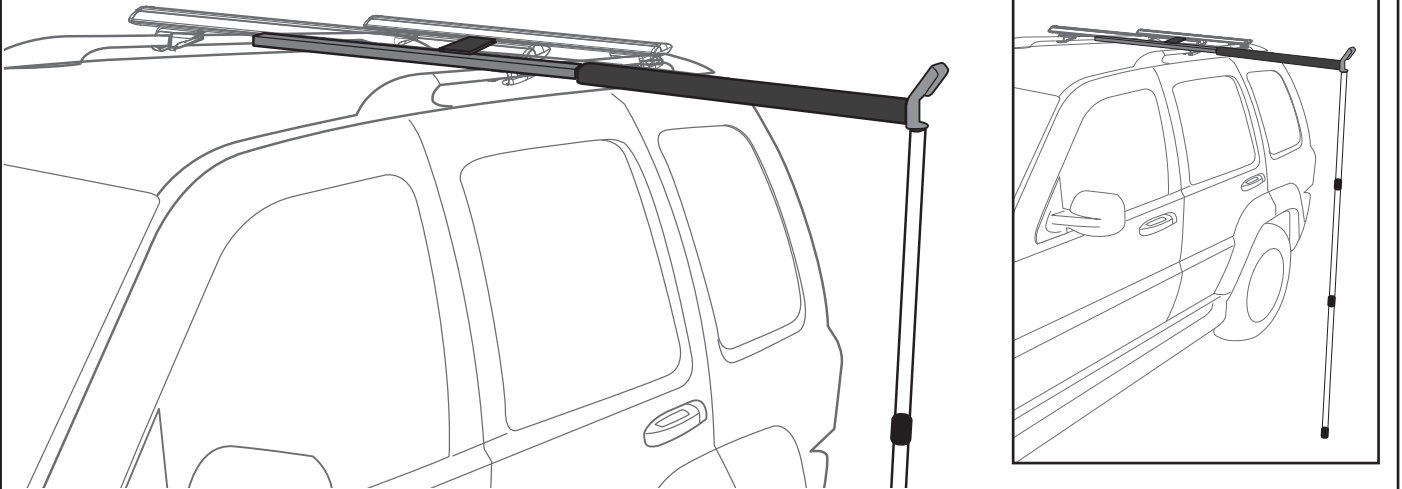

Important Information

Maximum carrying capacity: 60kg (132lbs) WITH THE USE OF THE SUPPORT POLE INCLUDED

Please refer to your vehicle manufacturers handbook for maximum carrying capacity of your roof racks. Always use the lower of the two figures. Load must be evenly distributed over the crossbars.

Warning: This product requires a certain level of manual handling of long and sometimes heavy objects. Ensure that you have assessed the following criteria before carrying out a lift:

Your physical ability and strength

Your general state of health and fitness

Dimensions of the object, such as height, reach and grip areas

Warning: The vehicle must be positioned on a flat surface. Ensure the long load has sufficient grip on the lower end to avoid slipping and potential damage to vehicle or object

Warning: Do not attempt to fit the RUSL to your vehicle unless you fully understand this fitting instructions. Please direct any questions regarding fitting to the dealer from where the RUSL was purchased. **Use only non-stretch fastening ropes or straps.**

Recommendations:

It is essential that all bolt connections be checked after driving a short distance when you first install your roof racks and RUSL. Bolt connections should be checked again at regular intervals (once a week is enough, depending on road conditions, usage, loads and distances travelled). You should also check the roof racks and RUSL each time they are re-fitted. Always make sure to fasten your load securely. Please also ensure that all loads are evenly distributed and that the centre of gravity is kept as low as possible. Long loads (e.g. canoes and kayaks) must be secured front and rear with non-stretch fastening ropes or straps.

Roof racks must be removed when putting vehicle through an automatic car wash.

Caution: The handling characteristics of the vehicle changes when you transport a load on the roof. For safety reasons we recommend you exercise extreme care when transporting wind-resistant loads. Special consideration must be taken into account when cornering and braking.

Note for Dealers and Fitters

It is your responsibility to ensure this fitting instruction is given to the end user or client

Rhino-Rack
3 Pike Street, Rydalmere,
NSW 2116, Australia.
(Ph) (02) 9638 4744
(Fax) (02) 9638 4822

Document No: R219
Prepared By: Andy Wana
Authorised By: Chris Murty

Issue No: 01
Issue Date: 17/04/2012

These instructions remain the property of Rhino-Rack Australia Pty Ltd and may not be used or changed for any other purpose than intended.



Rhino-Rack S-Loader (RUSL)

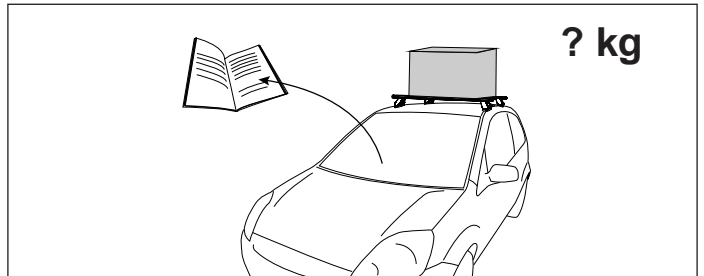
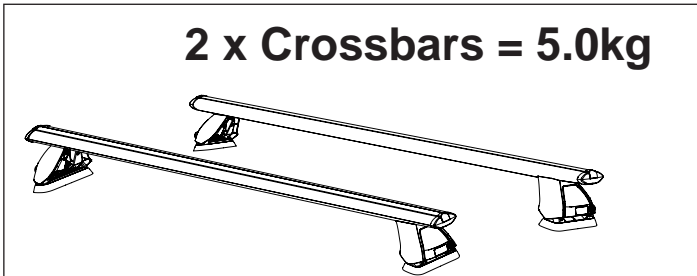
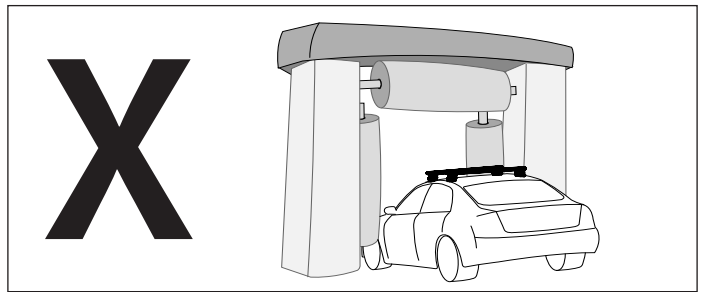
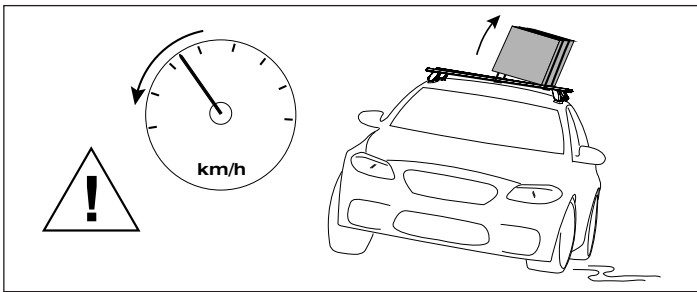
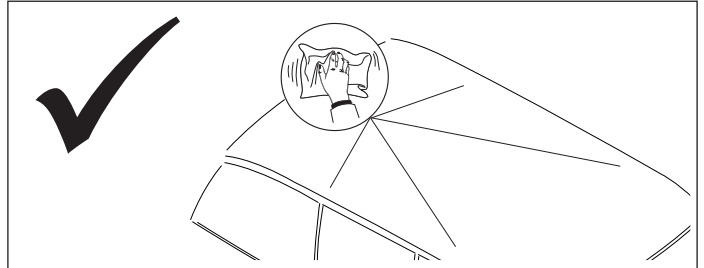
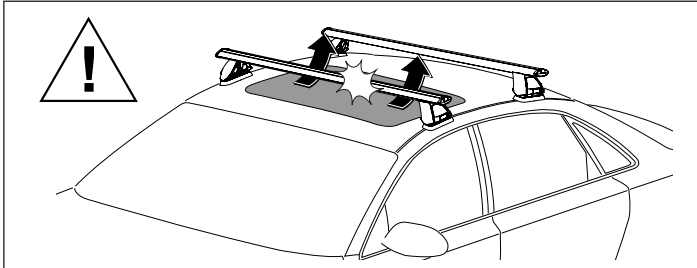
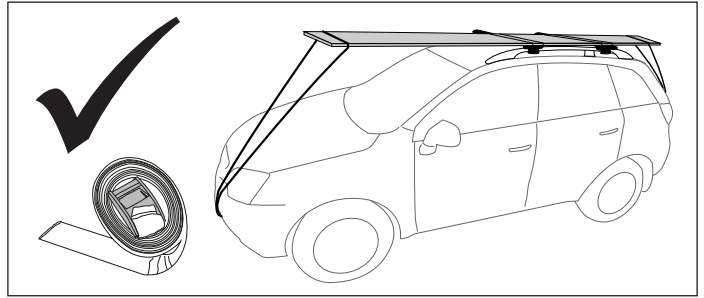
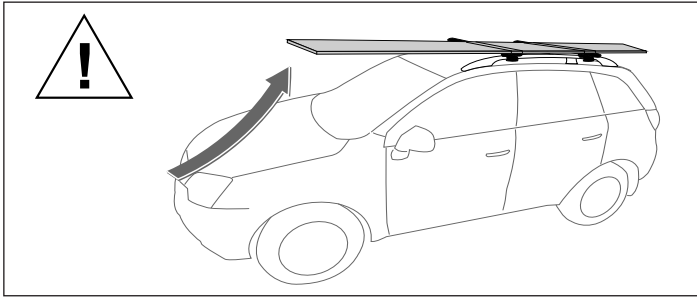

When these roof racks are to be used on a vehicle that is driven off sealed roads, the manufacturer maximum roof load rating (to be found in the vehicles User Manual) should be **halved**. Do not forget to subtract 7.5kg from your maximum carrying capacity due to the weight of the crossbars and legs.

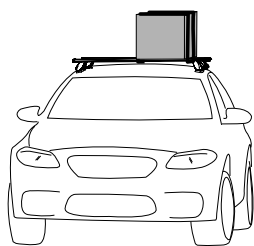

60kg load rating (Urban road) = **30kg load rating** (Off road - 60kg / 2)

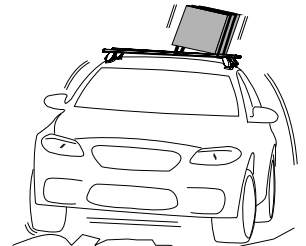

WARNING! Important Load Carrying Instructions

With utility vehicles, the cabin and the canopy move independently. Roof racks and vehicle can be damaged if the item transported is rigidly fixed at points on both the cabin and canopy. Instead, rigidly fix to either the cabin roof racks or the canopy roof racks.

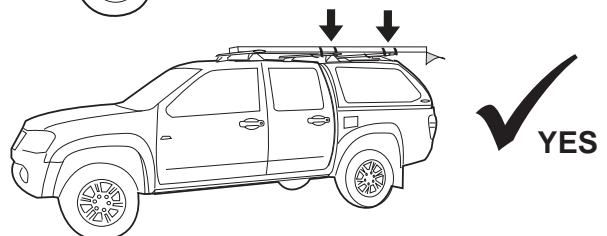
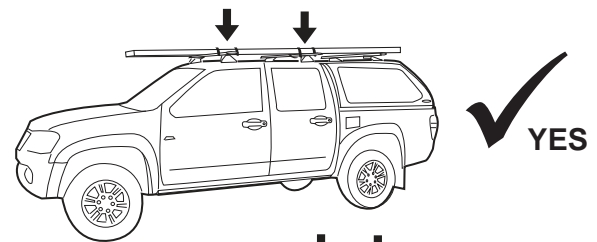
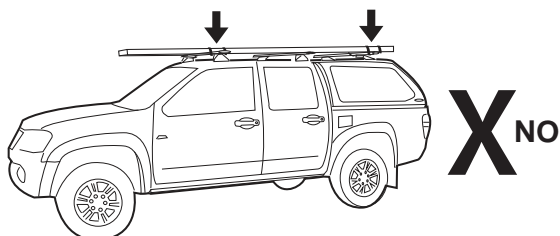



Rhino-Rack S-Loader (RUSL)

Parts List

Item	Component Name	Qty	Part No
1	3 stage support pole (2.2 metres)	1	RUSL
2	S-loader A	1	
3	S-loader B	1	
4	Storage Bag	1	
5	Clamp 1 (refer to step 5)	1	
6	Clamp 2 (refer to step 5)	1	
7	Clamp 3 (refer to step 5)	1	
8	Clamp 4 (refer to step 5)	1	
9	Clamp 5 (refer to step 5)	1	
10	Clamp 6 (refer to step 5)	1	
11	4mm Allen Key	1	
12	Fitting Instruction	1	

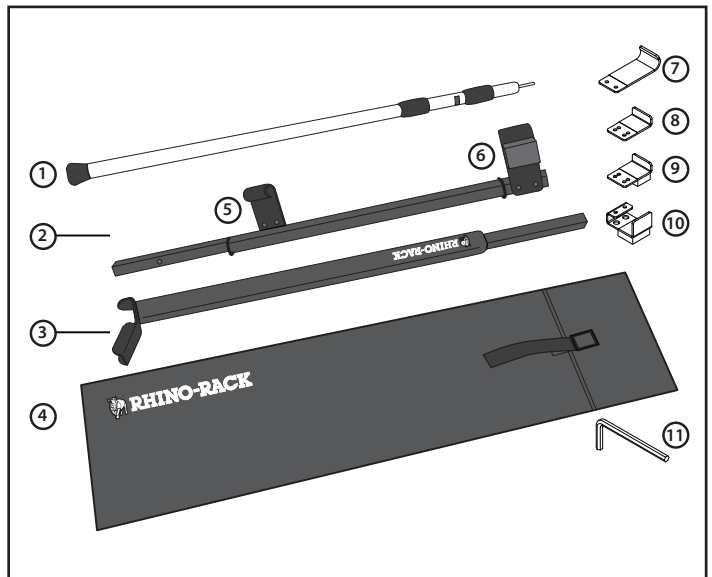

Care Instruction: Wash and clean vehicle roof racks prior to fitment

1 The S-Loader is pre assembled and ready for use with the following cross bars:

- Rhino-Rack Aero Bar
- Rola Aero Bar
- Thule Wingbar

Clamp at position A facing down as shown

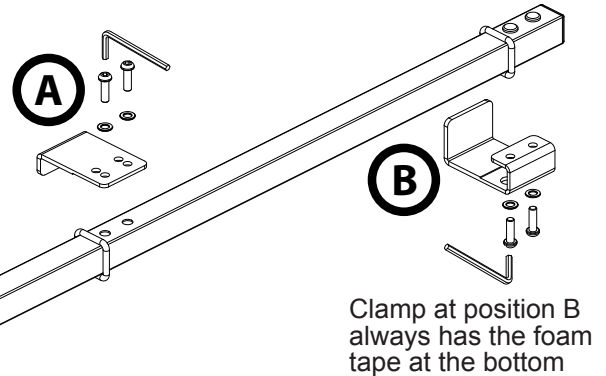

Clamp at position B always has the foam tape at the bottom

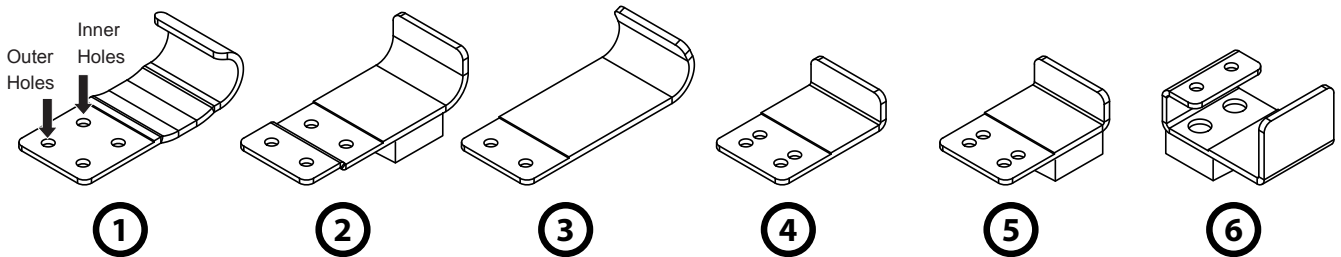

Crossbar Type	Clamp A	Clamp B	Clamp A position	Clamp B position
Rhino Rack Aero	1	2	Outer Holes	
Rhino Rack HD	4	6	Outer Holes	n/a
Rhino Rack Euro	4	5	Outer Holes	Inner Holes
Thule Aero	1	2	Inner Holes	
Thule Square	4	5	Inner Holes	
Thule Wingbar	1	2	Outer Holes	
Rola Aero	1	2	Outer Holes	
Pro-Rack P Bar	4	5	Inner Holes	
Pro-Rack Trade Bar	4	6	Outer Holes	n/a
Pro-Rack Whipbar	1	3	Outer Holes	n/a
Yakima Whipbar	1	3	Outer Holes	n/a



Rhino-Rack S-Loader (RUSL)

2 Assemble S-loader as shown

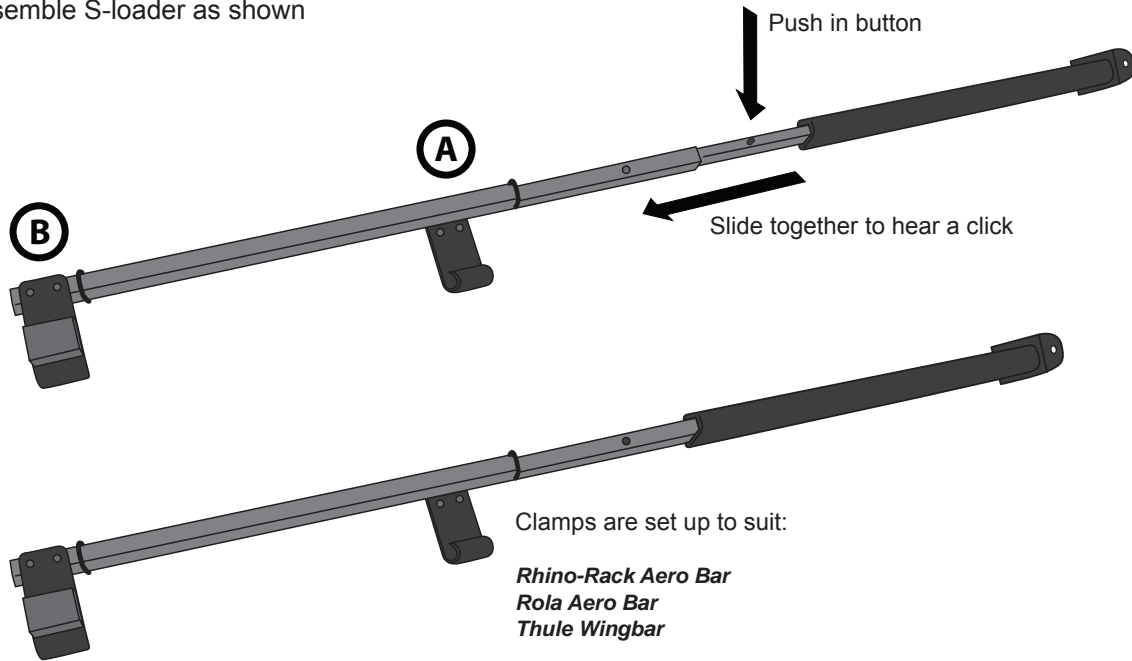

3 Insert clamp B under crossbar carefully

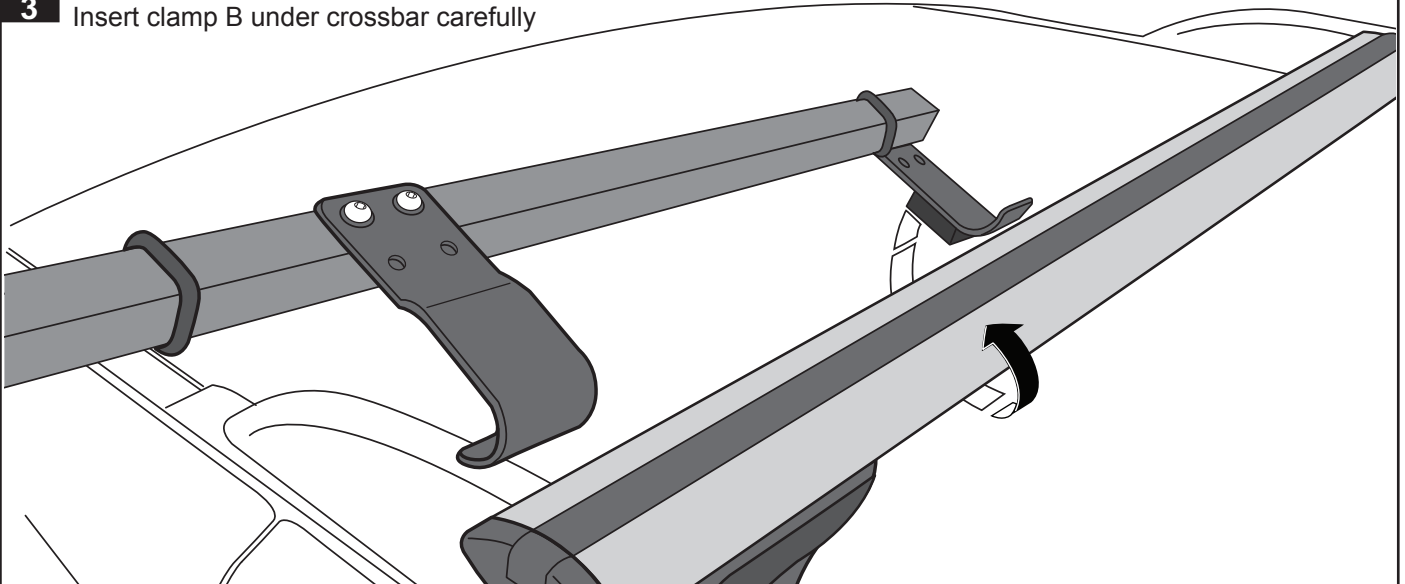

3 Rotate around to locate clamp A

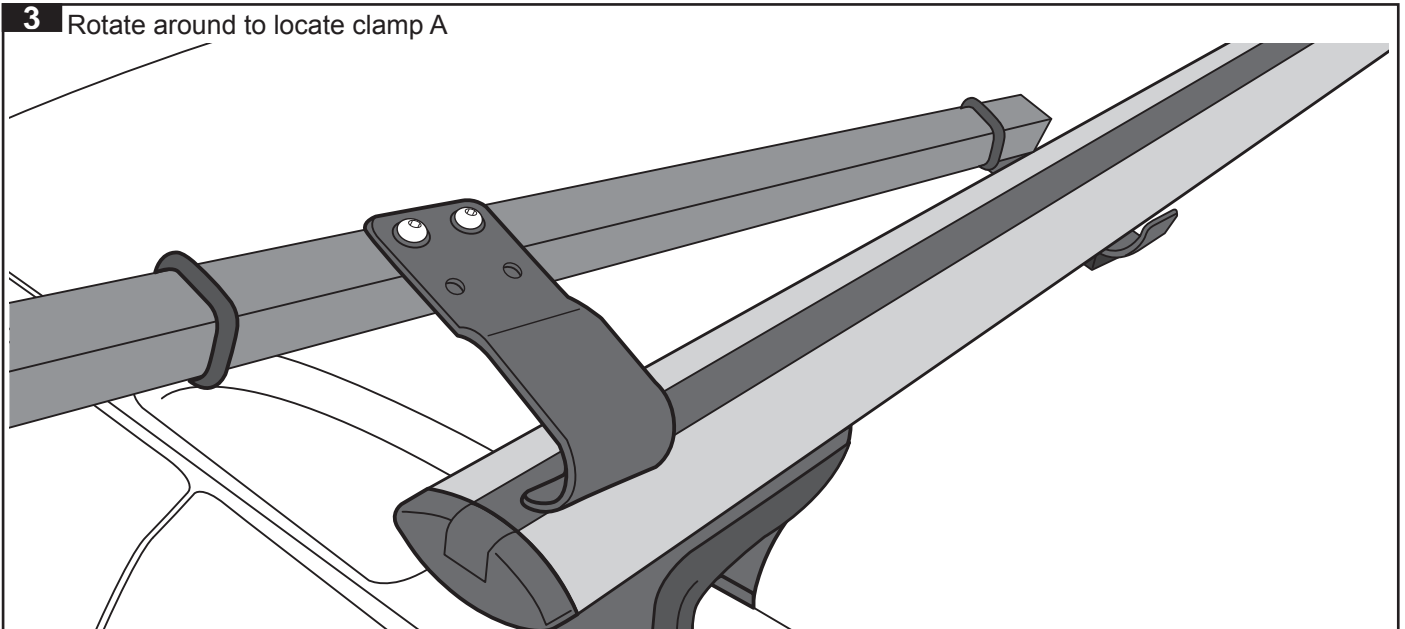



Rhino-Rack S-Loader (RUSL)

5

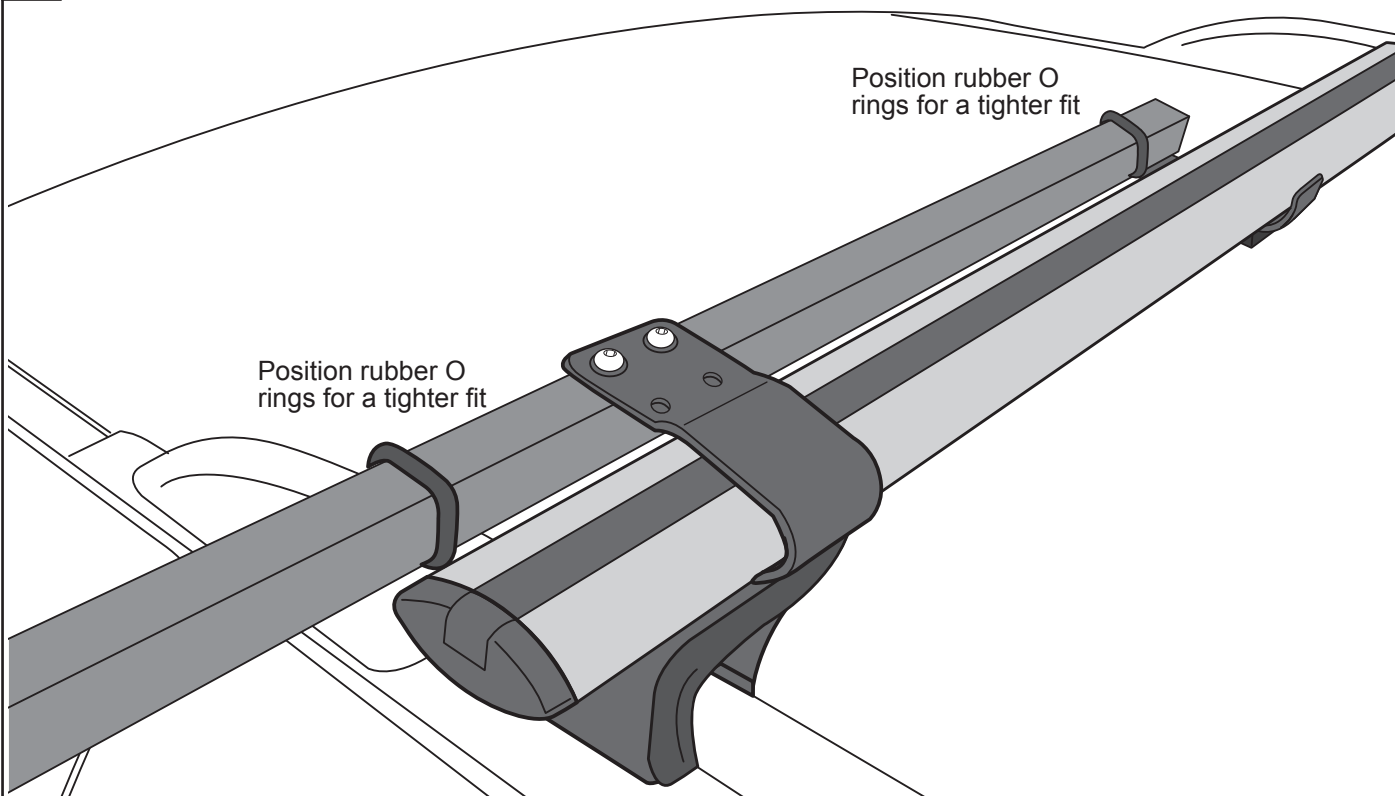

6

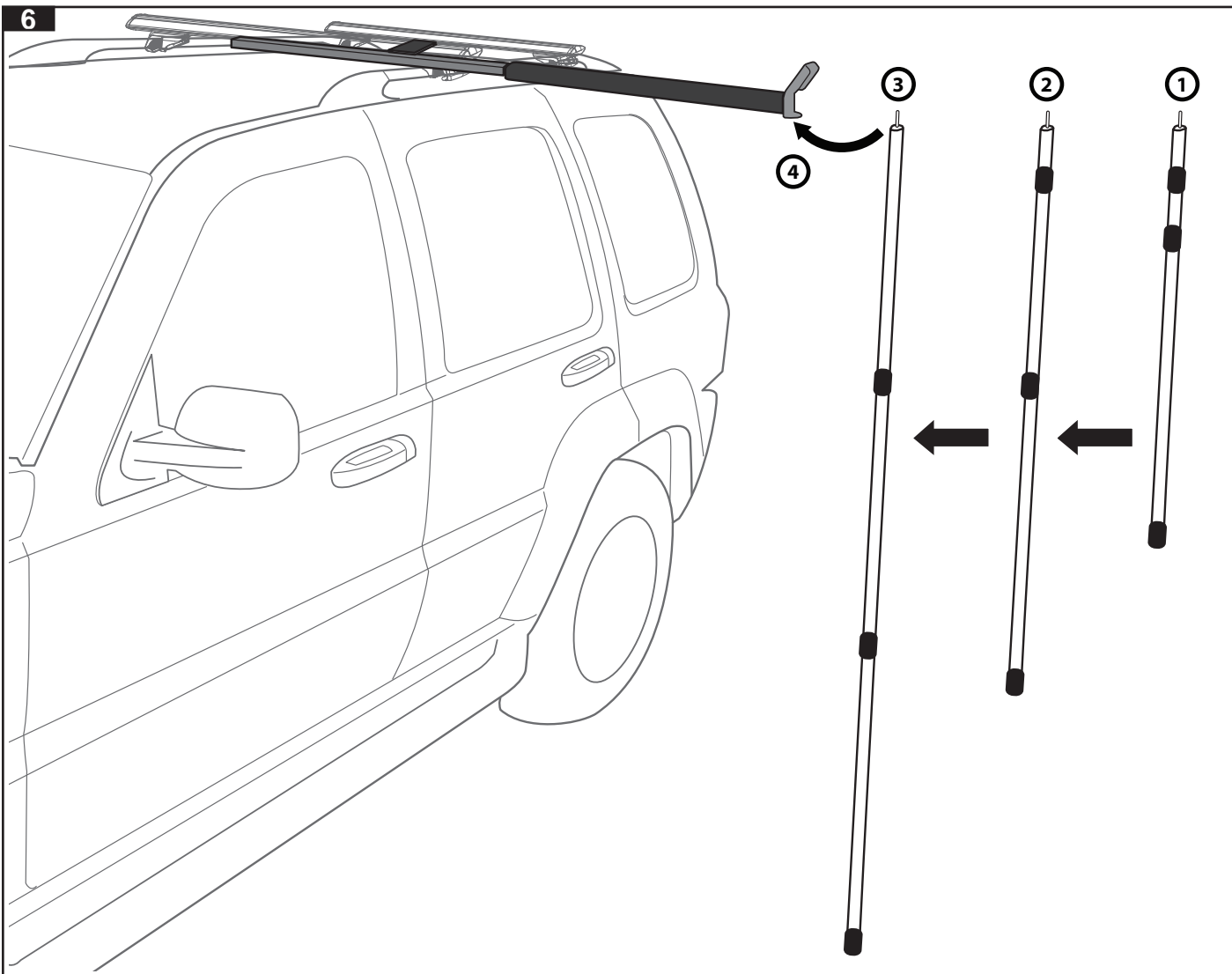



Rhino-Rack S-Loader (RUSL)

7

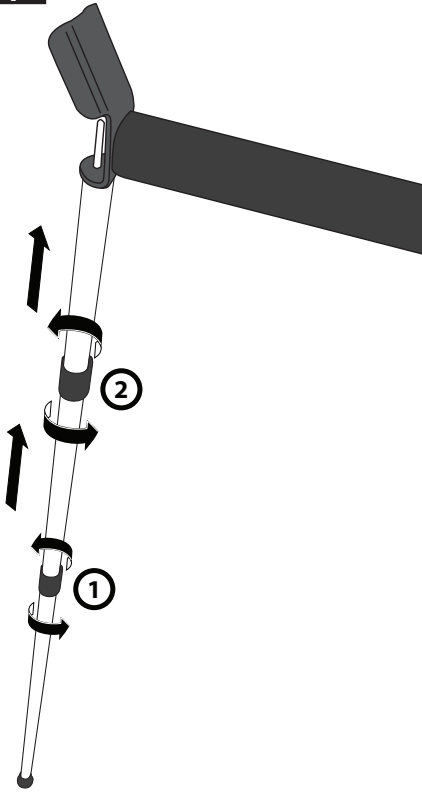

8

Position support pole so it allows the S-loader to sit horizontal

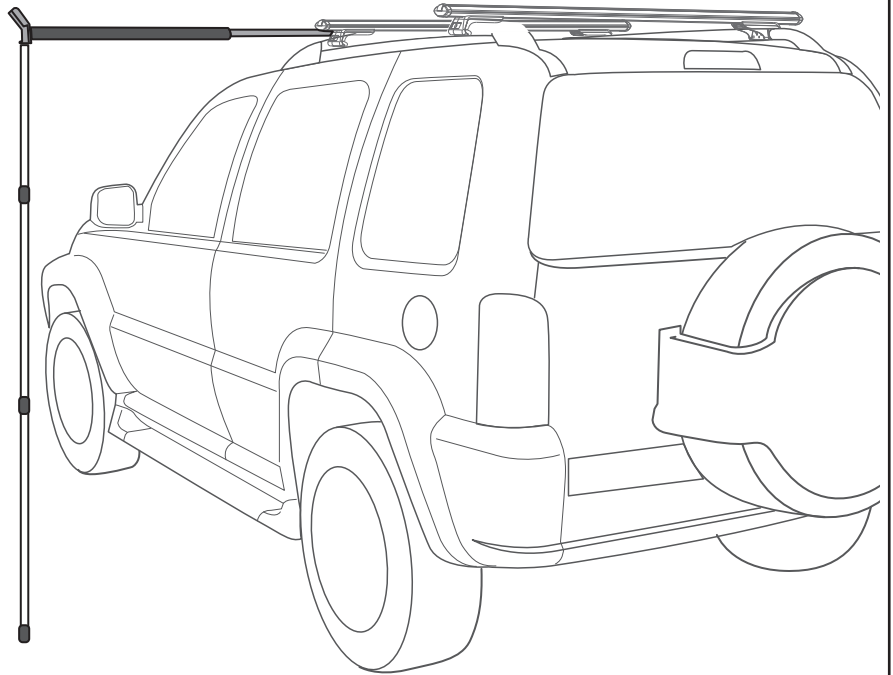

9

Carefully position load so it can be lifted up onto the S-loader. Ensure the lower end has sufficient grip as not to slip when loading

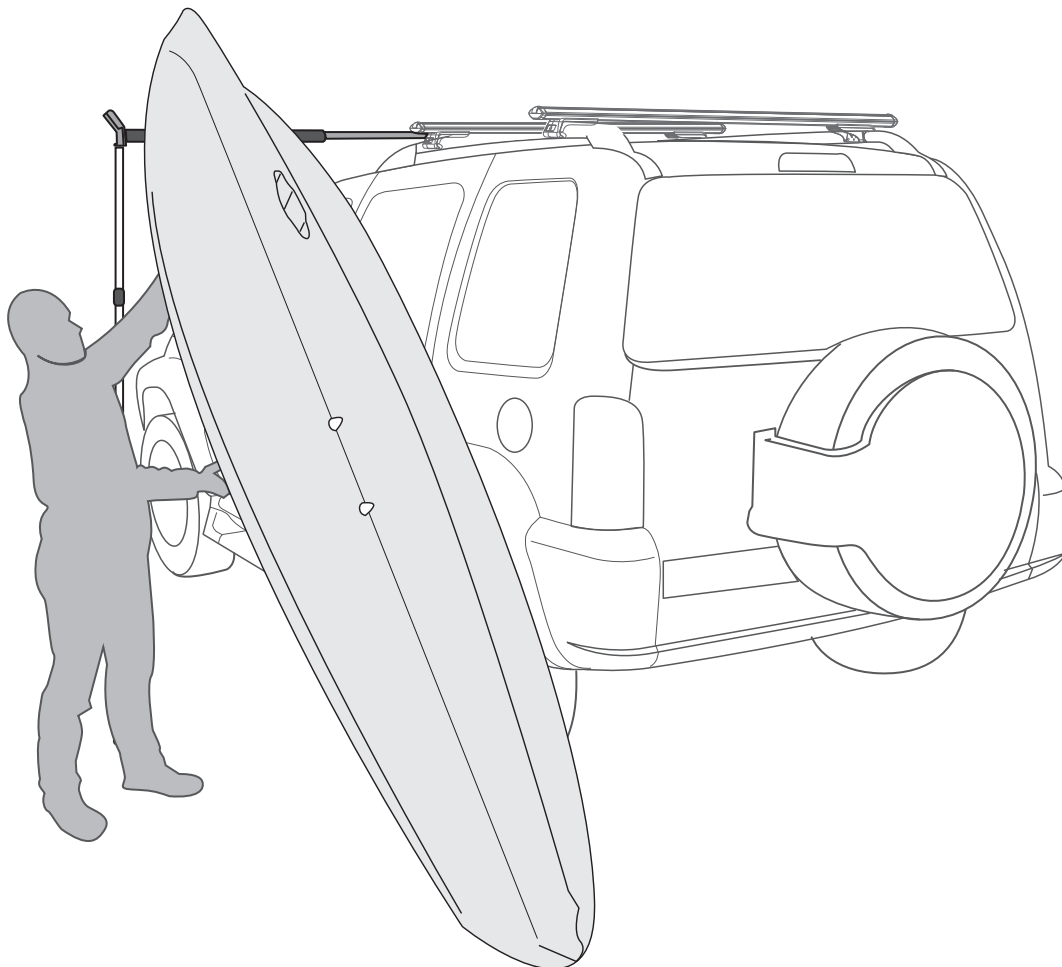



Rhino-Rack S-Loader (RUSL)

- 10** Lift the lower end and pivot the load across onto the roof racks. Do not slide, only pivot.

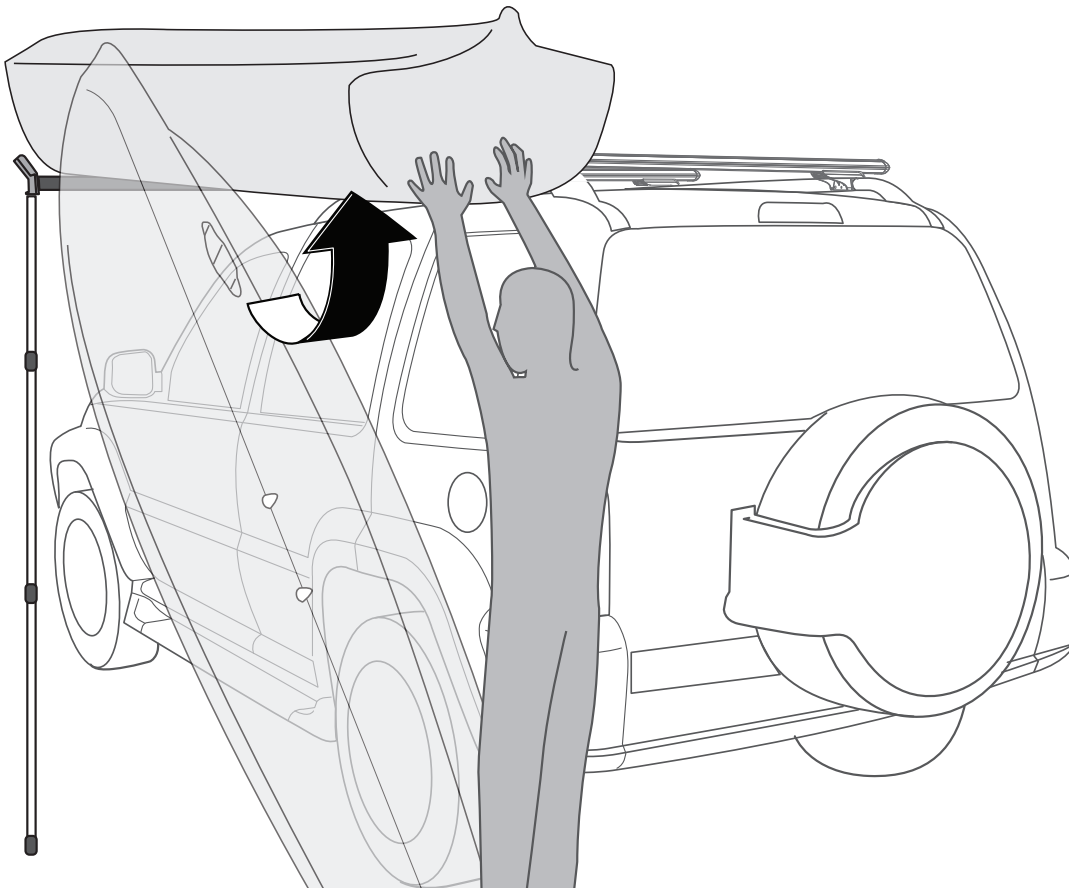

- 11** Pivot front of load onto both cross bars

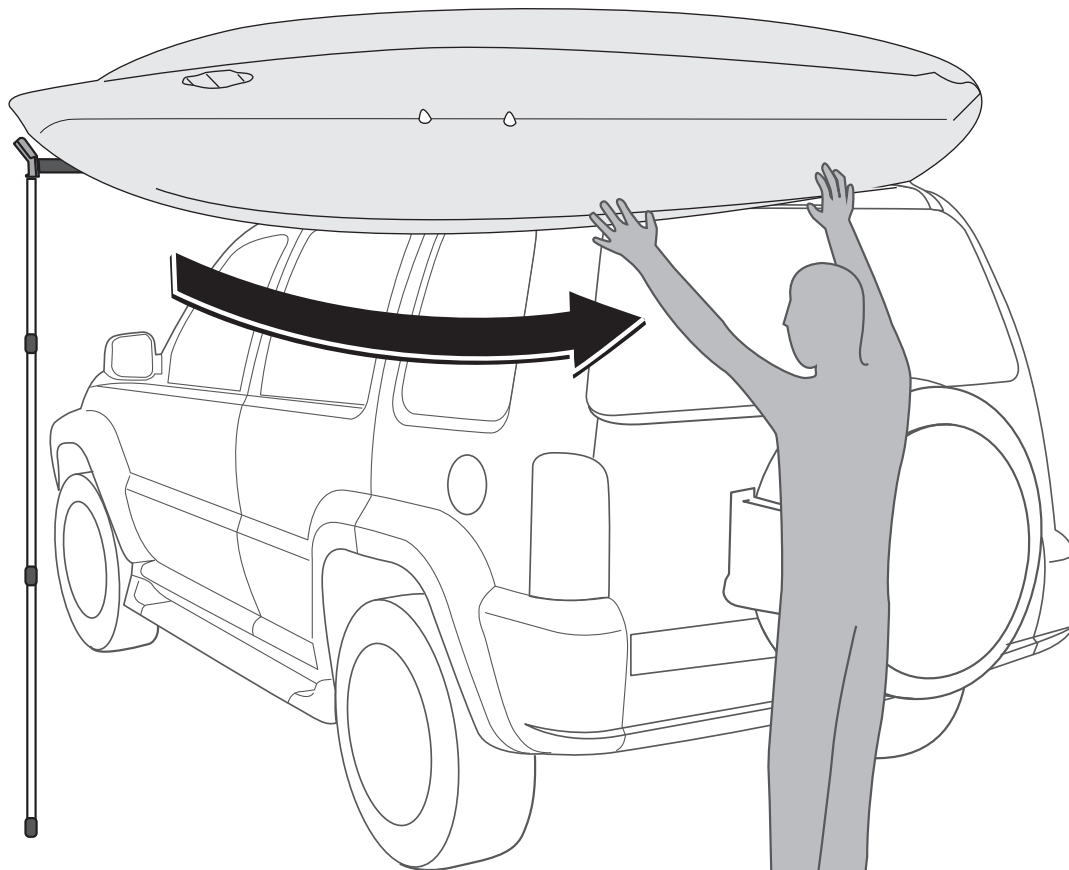



Rhino-Rack S-Loader (RUSL)

- 12** Pivot front of load onto both cross bars

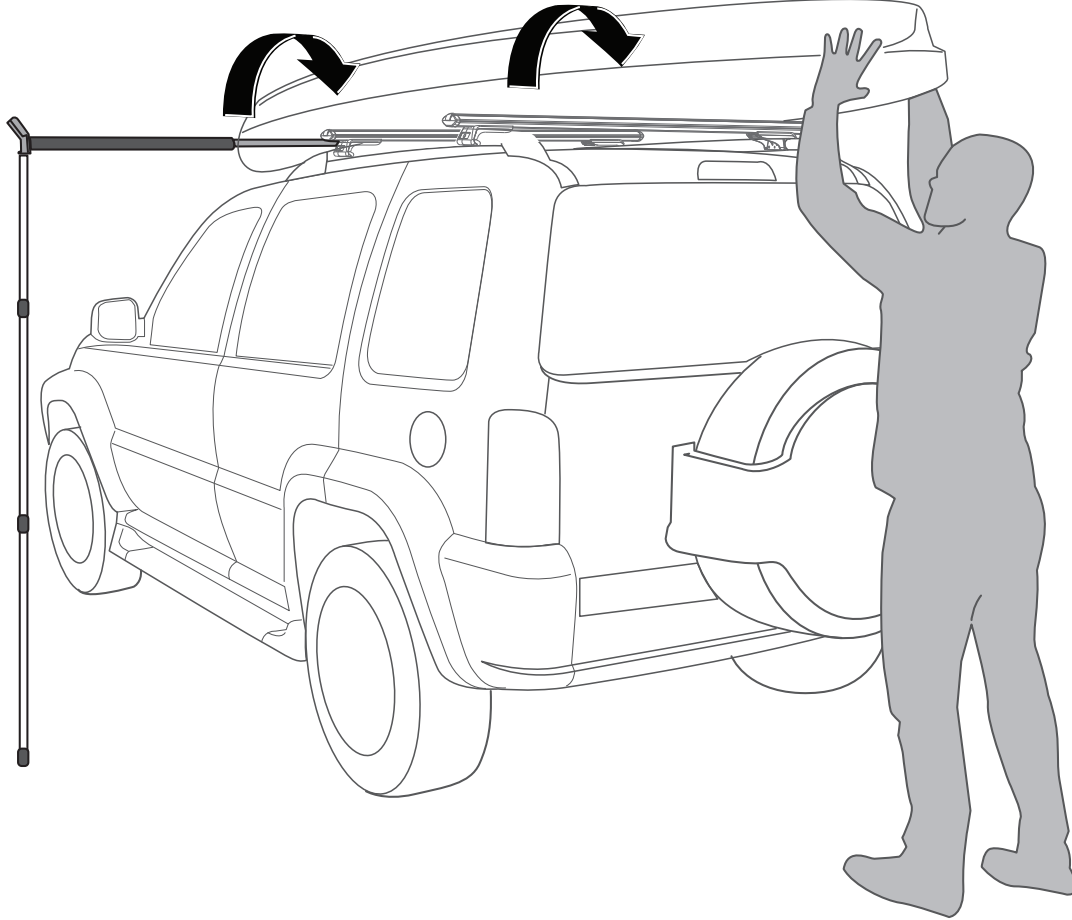

- 13** S-loader can now be removed and stored back in the carry bag. Ensure that the S-loader is stored away dry. Remove any moisture from unit. Tie down load securely with non-stretch tie down straps. Reverse steps 13 - 9 for unloading procedure.

