

**PARAGON ELECTRIC, INC**

License #81712

P.O. Box 8269 / Albuquerque, NM 87198

(505) 265-5883

# PARAGON ELECTRIC, INC. LIQUID LEVEL CONTROLLER USER MANUAL

MODELS:  
LLC-I, LLC-II  
AND TELEMETRY OPTIONS

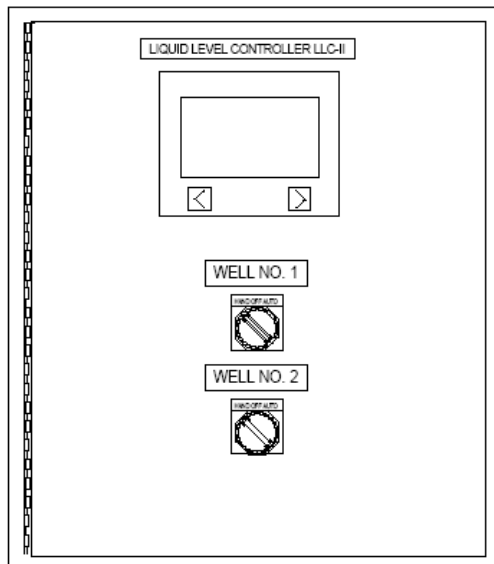



# Table of Contents

Safety .....	4
Introduction.....	5
Features and Benefits .....	6
Control Overview.....	7
Selector Switches.....	7
Panel Display (PanelView 300 Micro) .....	7
Navigation .....	8
Menus.....	9
Main Screen .....	9
Alarms.....	12
Troubleshooting .....	12
Pump Statistics .....	13
Setpoints .....	15
Pump Mode .....	16
Alternate Mode.....	17
Pump 1 Lead Mode.....	17
Pump 2 Lead Mode.....	17
Both Pumps Run Mode .....	17
Specifications .....	18
Troubleshooting.....	19
Replacement Parts.....	23
Dimensions and Layout.....	24
Options .....	25
Telemetry Option for LLC.....	25
Telemetry Option for Slave Unit .....	25
Surge Protection .....	27
Wiring Diagrams and Terminations .....	28

## Safety

The products discussed in this manual utilize electrical energy which can be hazardous or fatal. Do not open the panel cover unless all power to the panel has been removed.

**WARNING:** Note that it is possible for there to be more than one power source available in the control panel (such as control power and chemical metering pump power). Be sure to de-energize and lock out all potential power sources to the panel.

Wear safety goggles and insulated gloves to check that all power has been removed in panel using a rated tester.

If you are not sure how to deal with the inside of this panel safely, call a registered electrician.

# Introduction

The Paragon Electric, Inc. Liquid Level Controller automatically controls water storage tank level utilizing pressure sensing at well or pumphouse locations. The LLC-I controls one well pump and the LLC-II controls two well pumps. Pumps are turned on and off based on tank level setpoints defined by the user.

## Features and Benefits

With the Paragon Electric, Inc. Liquid Level Controller, nothing is installed at the storage tank. Tank Level sensing is accomplished at the pumphouse. The control panel and pressure transducer are installed in one location for ease of use and maintenance. Pump start/stop and running pressures are automatically filtered out of the transmission line to provide accurate tank level indication.

In addition to tank level control the LLC-I and LLC-II have the following features and benefits:

1. Tank level indication
2. Pump status logging including:
  - Elapsed run time
  - Pump starts for each pump
  - Pump fails for each pump.
3. Alarming including:
  - High and low tank levels
  - Pump failure
  - Transducer or transducer cable failure
  - Radio signal loss (telemetry option only)
4. Pump running status indication
5. Pump run mode selection (LLC-II only) including:
  - Alternate
  - Pump 1 Lead
  - Pump 2 Lead
  - Both pumps run simultaneously
6. The control panel is manufactured using reliable, industrial-grade parts which are all readily available.
7. Equipment is protected from surges by fusing and two levels of surge suppression. Controller components are further protected by power supply isolation. The main components are all 24VDC. Setup and operation is easy due to the enhanced graphical user interface. The user enters tank height, current tank level and tank levels with one or more pumps running to automatically calibrate the unit for tank level monitoring (see installation section of the manual).

## Control Overview

Well pumps are controlled using the selector switches on the front of the panel and by using the panel display (PanelView 300).

### Selector Switches

Each pump can be controlled with the Hand-Off-Auto selector switch provided on the front of the Liquid Level Controller. (The LLC-I has one selector switch and the LLC-II has two.)

#### HAND

Hand mode will run the pump regardless of whether the controller is calling for automatic run or not. Hand mode will work even if controller components have failed or controller power is off.

#### OFF

Off mode will not allow the pump to run.

#### AUTO

Auto mode will run the pump based on the user defined setpoints. When the storage tank level drops to the start setpoint the pump will start and run until the storage tank level reaches the stop setpoint. (More details on auto mode can be found in the pump mode section of the manual.)

### Panel Display (PanelView 300 Micro)

Access to the Liquid Level Controller processor information is accomplished by using the panel display interface. Tank level, pump run status, pump statistics, as well as other information can be viewed using this display. Setpoints such as pump start level and stop level can be viewed and changed through the display as well. In addition, startup and calibration data can be viewed and changed. No computer is needed to setup the Liquid Level Controller.

# Navigation

To navigate the controls use the “F” keys and navigation arrows located on the display.

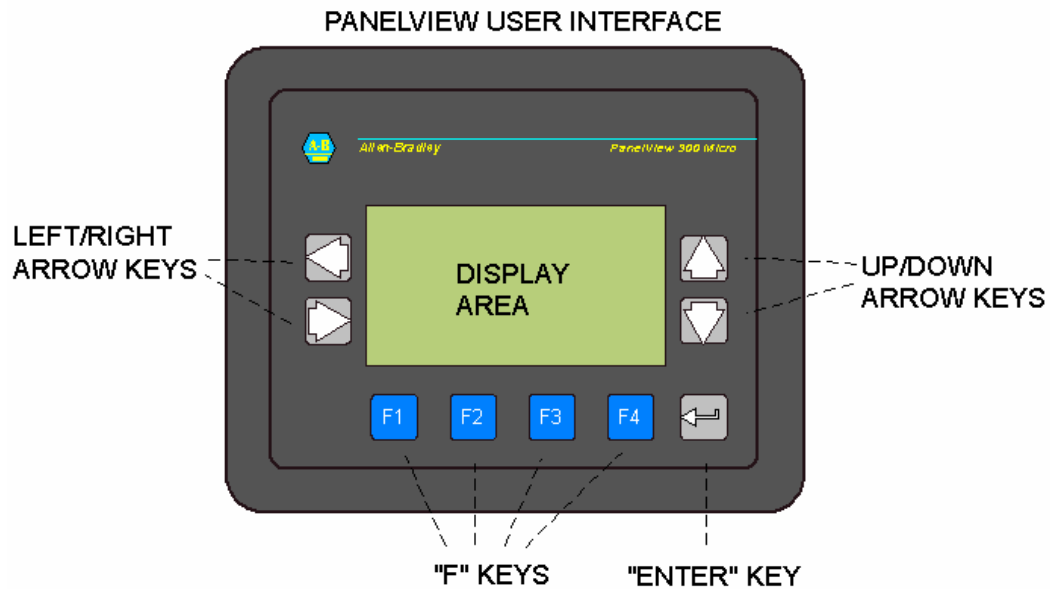

“F” keys are used to select the four major menus as well as select objects in the display area. Left and right arrows can be used to navigate within a selected menu or to navigate within a selected entry such as a setpoint. Up and down arrow keys are used to change values of data. The enter key is used to select highlighted menu choices or confirm entered data.



# Menus

The Paragon Electric Liquid Level Controller has four main menus. These menus are selected using the “F” buttons on the bottom of the user display. For convenience, these four menus are shown just to the right of the controller.

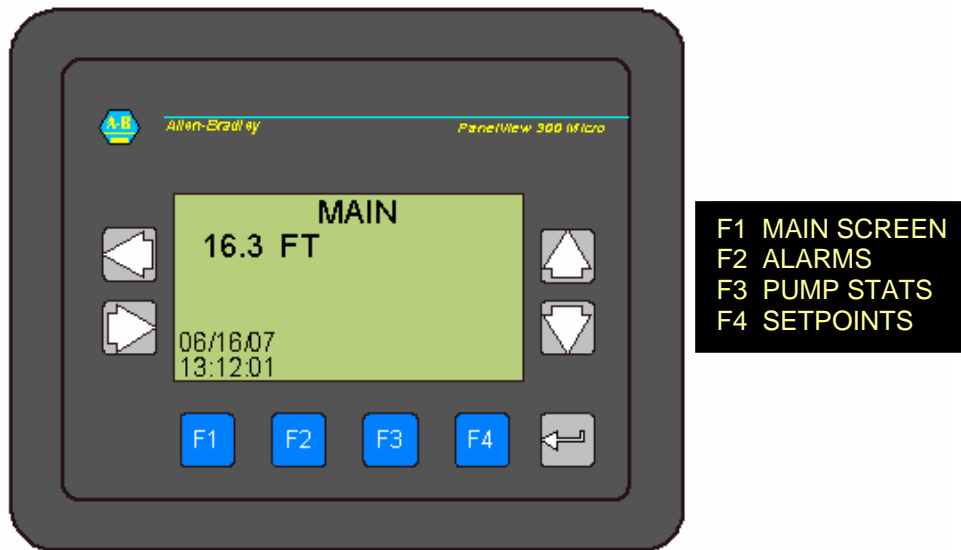

## Main Screen

The main screen shows the time and date as well as tank level and pump status. The tank level is shown in feet from the bottom of the storage tank floor. The pump status will indicate if a pump is running or has failed (see troubleshooting). For LLC-I units only one pump running or fail indication will be available. For LLC-II units, status information of two pumps will be available.

## Tank Level

The tank level is displayed and represents the water level in feet above the water storage tank floor.

## Pump Running Status

If either pump is running (only one pump for the LLC-I) the screen will display "PUMP 1" or "PUMP 2" or both depending on which pump or pumps is running.

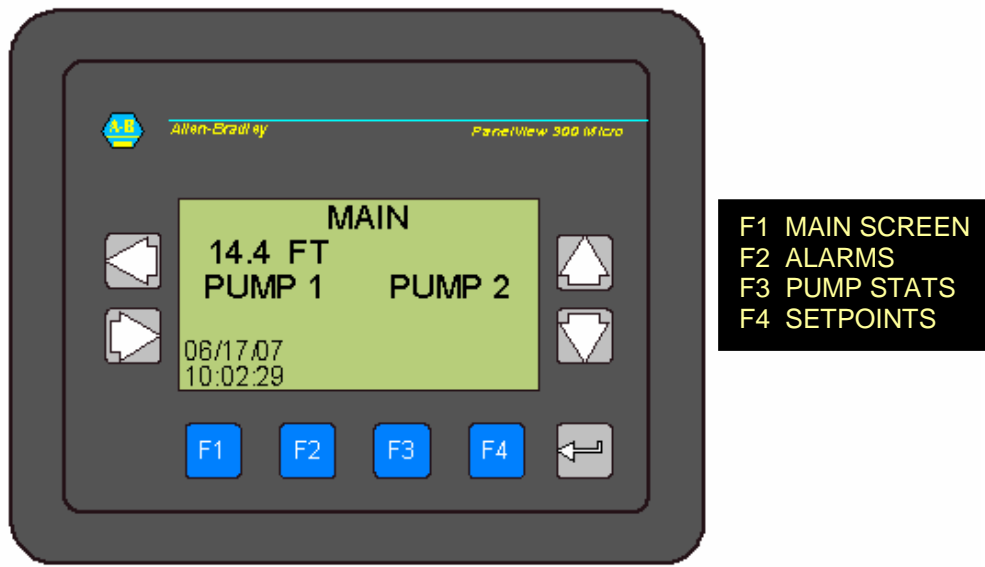

## Pump Fail Status

If a pump is in hand mode or in auto mode and is being called to run, but the controller does not sense a running condition, a pump fail indicator will be shown such as, “P1 FAIL” or “P2 FAIL” (only one pump for the LLC-I). These indicators will flash in order to draw attention. If the controller senses that either pump has failed, the common alarm relay will be energized and any attached alarm output will be actuated (such as an alarm beacon). Check the troubleshooting section of this manual for details of pump fail indication and causes.

The main screen will also indicate if an alarm is present as indicated by the flashing alarm banner.

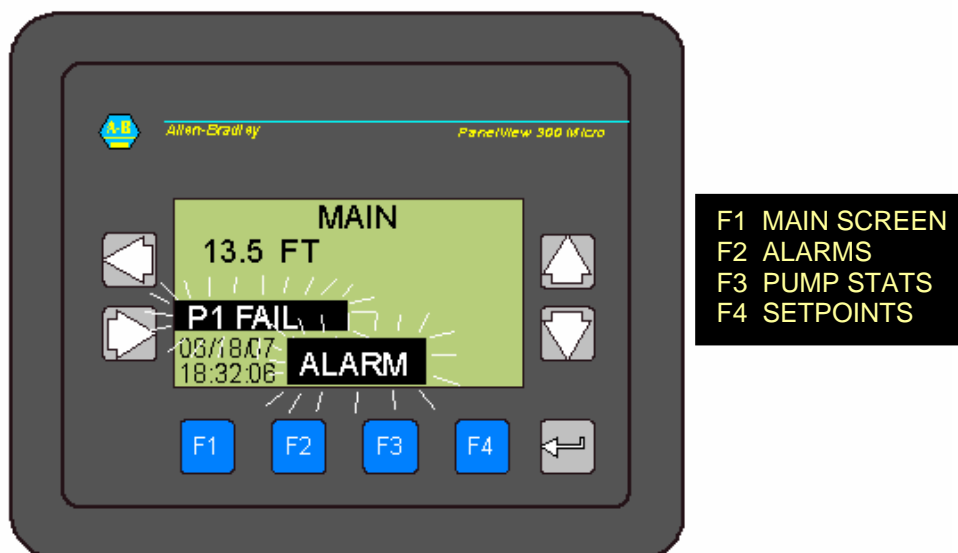

## Alarms

If the ALARM indicator is flashing the alarm menu can be accessed by pressing the “F2” button. This screen will show any present alarms. Under normal conditions none of the alarms shown below should be present. Acknowledging the alarms will turn off the common alarm relay, which will turn off any attached alarm output (alarm beacon, autodialer, etc.)

Note: F1, F3 and F4 still access the MAIN, PUMP STATS AND SETPOINTS menus respectively.

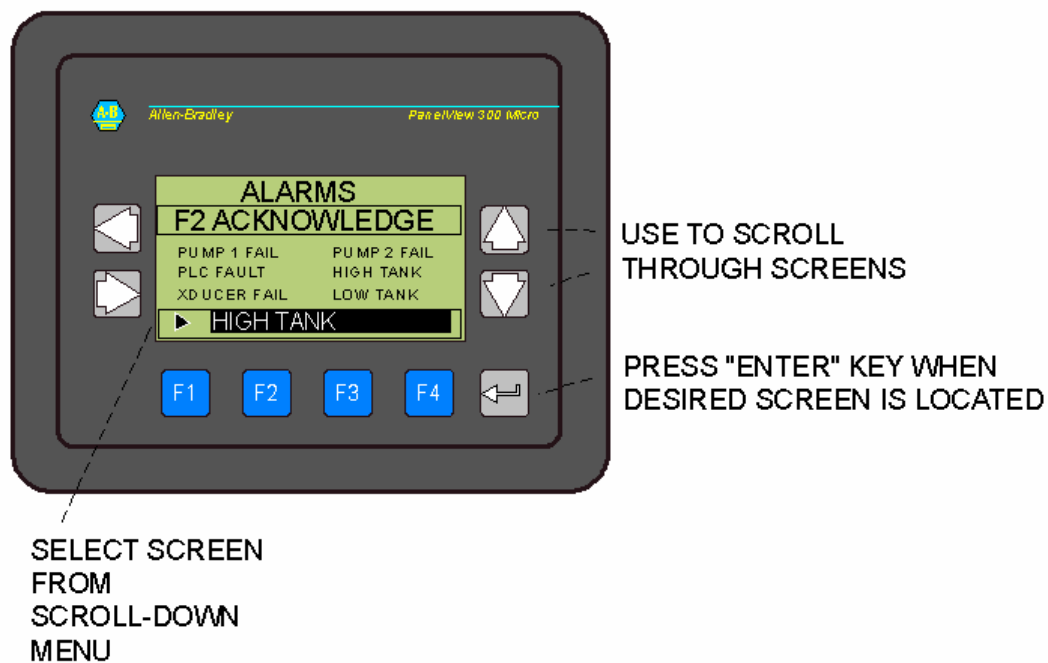

## Troubleshooting

The troubleshooting menu provides access to the controller’s troubleshooting feature. Using the up and down arrows, screens can be accessed for each alarm condition. Press the up or down arrow until the desired troubleshooting page is found and then press enter.

Here a text will be displayed to briefly explain alarm condition as well as possible solutions.

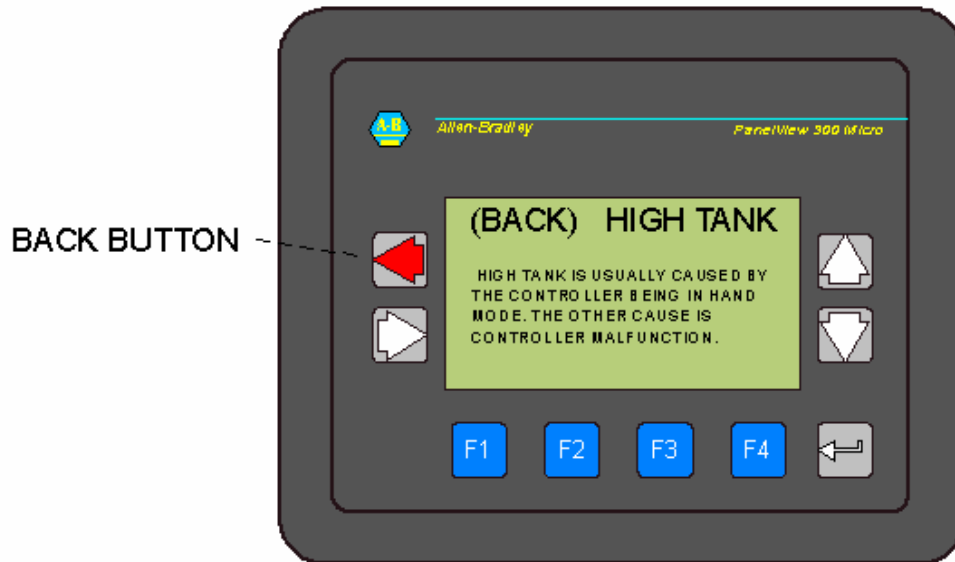

To get back to the alarm screen use the left arrow key.

Note: F1, F3 and F4 still access the MAIN, PUMP STATS AND SETPOINTS menus respectively.

## Pump Statistics

Using the "F3" button will take you to the "PUMP STATS" screen. This screen has useful pump information such as run-time, pump starts and pump fails. Keeping track of this information can help assure that the pump is running a reasonable amount of time for each start and that it is not "failing" frequently. (See troubleshooting section of this manual if numerous fails are noted over any period of time.)

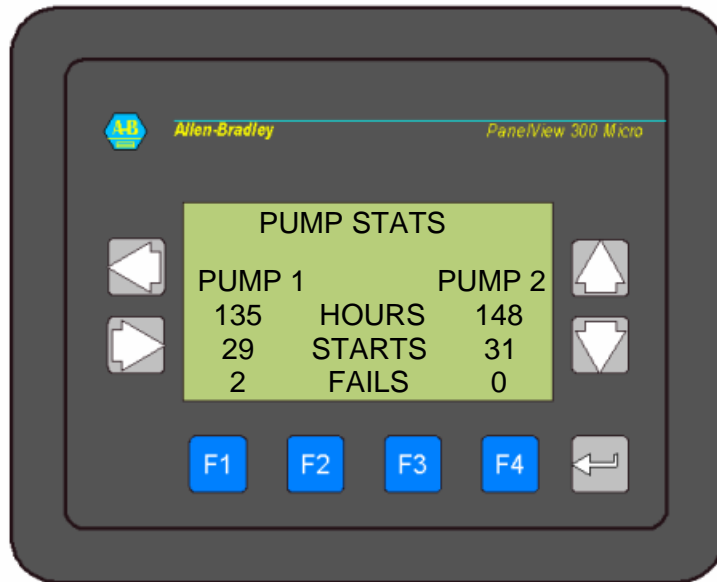

F1 MAIN SCREEN  
 F2 ALARMS  
 F3 PUMP STATS  
 F4 SETPOINTS

The above screen shows the Pump Statistics screen for the LLC-II. The LLC-I will not show any hours, starts or fails for “PUMP 2.” By dividing the “HOURS” by the “STARTS”, the average run time can be determined for each pump. In this case pump one is running an average of 4.66 hours per start (135/29=4.66). Pump fails can be caused by a number of situations. See the troubleshooting section of this manual for more information. Generally, there should be few or no fails.

Note: the Pump Statistics screen can be reset to zero if desired in one of the advanced setup menus. (See the Advanced section of this manual for details.)

## Setpoints

For setup and or to choose tank-level start and stop setpoints access the “SETPOINTS” menu by pressing the “F4” button.

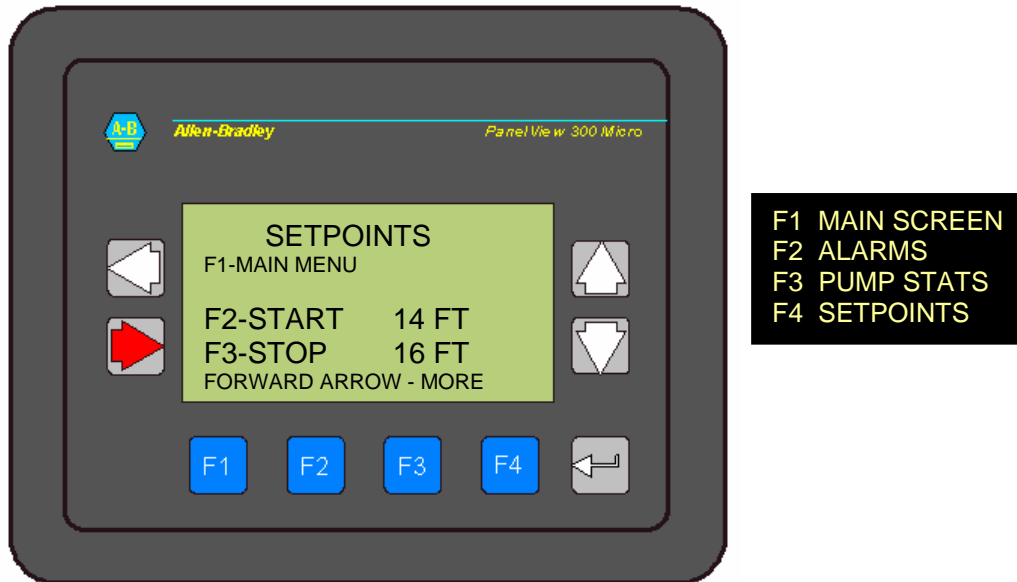

The “SETPOINTS” screen allows the user to change start and stop setpoints as well as navigate to setup and advanced screens. The “F2” button allows the user to enter the start setpoint and the “F3” button allows entry of the stop setpoint. For example: To set the start setpoint, press F2. A numeric data entry screen will be shown. Use the up/down arrows to increase or decrease the number. The left and right arrows will allow moving from one numeric place holder to another. Enter a whole number. Fractions or decimals are not allowed. Once the desired number is shown on the screen press the enter key. This will return you to the Setpoint screen.

Accessing additional screens is possible using the RIGHT (referred to as FORWARD ARROW on the display). These screens are for setup and advanced configuration and require a password. See the ADVANCED section of this manual for more information.

Generally, after initial setup, the only keys needed are the “F” keys to navigate between menus. The “SETPOINTS” menu is used during setup and to enter stop and start points for the pump. Otherwise only menus 1, 2, and 3 are needed for general monitoring of the system. To utilize other functions of the unit advanced screens can be accessed using a password.

## Pump Mode

By pressing the forward (right) arrow on the setpoints screen, the pump mode screen can be accessed. Use the up/down arrow keys to select the desired pump mode from the menu. When the arrow to the left of the menu points to the desired mode, press enter.

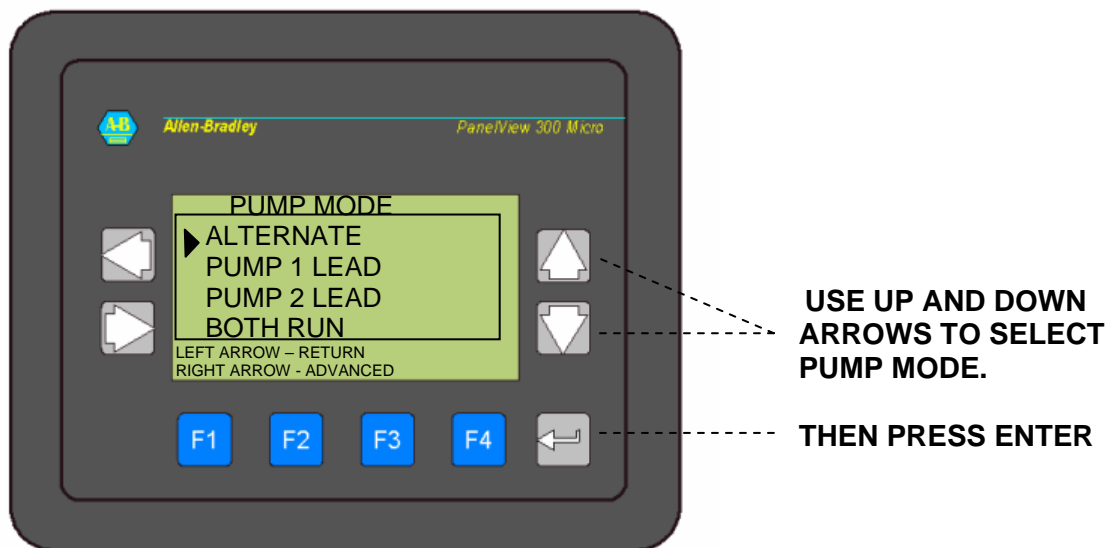

The left arrow changes the screen to the previous screen. The right arrow changes the screen to the advanced screen which requires a password to access.

The following mode descriptions apply to the LLC-II. If your controller is an LLC-I, the “PUMP 1 LEAD” mode should be selected.



## Alternate Mode

The alternate mode alternates pumps based on call for water signals created within the processor. In other words, when the tank level drops below the start setpoint, the first pump in the sequence is started and will run until the tank level reaches the stop setpoint. When the tank level again falls below the start setpoint, the next pump will start and will run until the tank level once again reaches the stop setpoint. This sequence will continue indefinitely. If for some reason the tank level drops one foot below the start setpoint, both pumps will be called to run. If the tank level drops two feet below the start setpoint, then the “Low Tank” alarm will be set.

## Pump 1 Lead Mode

Use this pump mode if the LLC-I is installed or if it is desired to run pump 1 more than pump 2, set the mode to “PUMP 1 LEAD.” The controller will start pump 1 every time the tank level drops below the start setpoint. Pump 2 will start only if the tank level continues to drop one foot below the start setpoint. If the tank level drops two feet below the start setpoint, then the “Low Tank” alarm will be set.

## Pump 2 Lead Mode

If it is desired to run pump 2 more than pump 1, set the mode to “PUMP 2 LEAD.” The controller will start pump 2 every time the tank level drops below the start setpoint. Pump 1 will start only if the tank level continues to drop one foot below the start setpoint. If the tank level drops two feet below the start setpoint, then the “Low Tank” alarm will be set.

## Both Pumps Run Mode

Use this mode if it is desired that both pumps run simultaneously. When the tank level drops below the start setpoint, both pumps will start and fill the tank until the stop setpoint is reached. If the tank level drops two feet below the start setpoint, then the “Low Tank” alarm will be set.

# Specifications

## Electrical

Power supply

120VAC, 15 or 20A

Power

84 watts max.

Alarm relay rating

7.5A @ 120VAC

Control power fusing

5A slow acting @ 120VAC

1/4" x1 1/4"

24VDC fusing

1A fast acting @ 24VDC

1/4" x1 1/4"

## Physical

Dimensions

16" H x 14" W x 8" D

Weight

12.6 lbs.

Enclosure rating

NEMA4

Operating temperature

32°F to 10°F

# Troubleshooting

PROBLEM	POSSIBLE CAUSE	SOLUTION
Display blank	Controller has no power.	Check the circuit breaker that feeds the controller. Make sure utility power is available.
	Controller fuse is blown.	Shut off power to controller. (see safety section at the beginning of this manual). Check fuses by visual inspection. (see illustration on page 22.)
Tank level is high.	Selector switch or switches in "HAND" mode.	Turn selector switches to off or auto.
	Controller is not configured properly.	Check that setpoints are within the range of the tank. Check that tank level reading on the display is the same as actual tank level.
Tank level is low.	Controller selector switch or switches in "OFF" mode.	Check that selector switch or switches are in hand or auto mode.
	Pump has no power.	Check that circuit breakers which feed the pump are on and not tripped. Check that there is utility power available.
	Pump has failed.	See pump failed section below.
	Controller not configured properly.	Check that setpoints are within the range of the tank. Check that tank level reading on the display is the same as actual tank level.

Xducer fail.	The pressure transducer is not registering with the controller.	Look for obvious problems such as a damaged cable at the transducer. Call installer for repair or replacement.
PLC Fault	The controller is faulted.	Call the installer for repair or replacement.
Pump 1 failed	The controller is calling the pump to run, but does not sense that the pump is running.	The pump has no power. Check the circuit breaker that feeds the pump and that there is utility power available.
		The pump overloads have tripped. Reset overloads. Multiple tripping usually indicates a pump problem. Consult well pump manual or call well pump installer.
		A motor saver associated with this pump is tripping. Consult the motor saver manual or call the installer of the motor saver.
Pump 2 failed	Same as pump 1 fail.	Same as pump 1 fail.
RF Fail	The telemetry signal is weak or missing. (This is only if telemetry option is installed).	Check that antennas or antenna cable has not been damaged. Check for obstructions that could interfere with the line of site, such as trees or shrubs that have grown in the radio path. Call the installer.

Over-frequent pump starts	Setpoints incorrectly configured	Check to see that the start and stop setpoints are adequately spaced. The greater the difference in the setpoints the longer the pump or pumps will run.
	Incorrect pump mode.	Try switching to an alternating mode on a two pump system if the mode is currently set to "BOTH PUMPS RUN."
	Motor saver is tripping.	Check to see that a motor saver or other device is not tripping and then automatically resetting. The pump should run for long periods (at least two hours) without stopping.
Motor never shuts off.	System leak.	Check for leaks in the water system.
	Pump output too small.	Check that pump is producing proper flow. Check that appropriate valves are open.

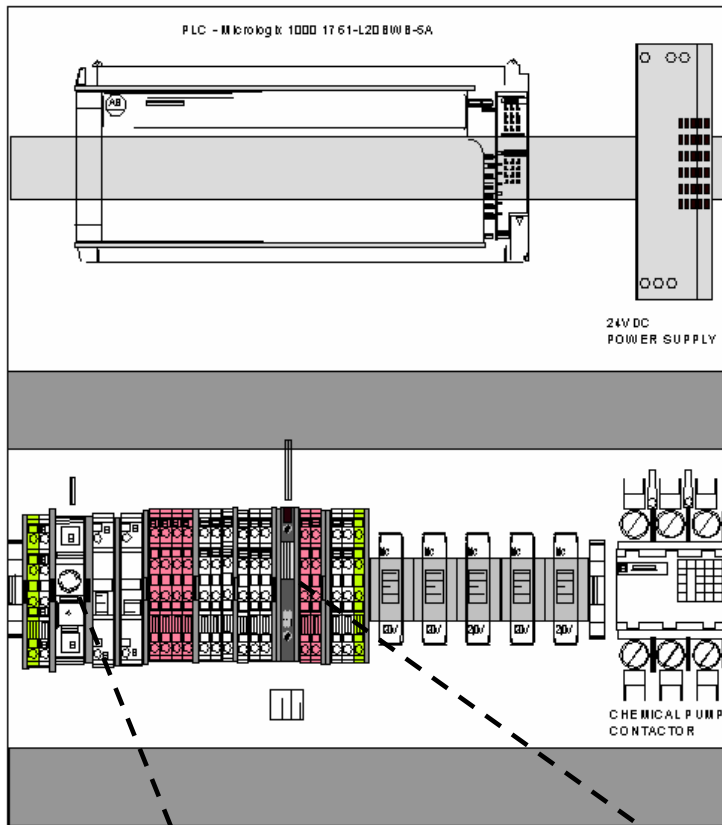

Control fuse – 5A slow acting

24VDC fuse – 1A fast acting

The most common problem with the controller is a blown controls fuse. This typically happens after a power surge occurs due to such occurrences as a lightning storm. If the display is blank and power is known to be at the building, check for a tripped circuit breaker. If this is not the case, remove power to the controller and check for a blown fuse (see safety procedures at the front of this manual).

The Control fuse is the most likely to blow in the event of surges. Unscrew the black knob till the fuse is released. There should be a small wire filament visible in the glass. If there is not replace with a spare (spares are provided with the controller). There are two types of spares used, the “slow-blow” which has a thicker element than the “fast blow”.

# Replacement parts

Qua	Item	Brand	Model
<b>Enclosures and Backplates</b>			
1	Enclosure Nema 12R	Carlton	NS16146
1	Backplate for above	Carlton	JP1614
<b>Relays</b>			
5	Ice cube 1 pole	Idec	RH1B-UL-120V
5	Bases for above	Idec	SH1B-05
<b>Terminal Blocks</b>			
9	Double deck TB, 300V, 20A, 70mmx5mm, 28-12AWG	Wago	870-501
10	End cap for 870-501 above	Wago	870-518
2	2 way Jumper bars for 870-501 above	Wago	870-402
2	Grounding TB 4 cond, 300V, 20A, 70mmx5mm, 28-12AWG	Wago	870-507
6	4 cond through block, 300V, 20A, 70mmx5mm, 28-12AWG	Wago	870-508
1	Fuse TB 1/4"x1 1/4" w/neon ind 120VAC, 10A,	Wago	282-128/281-418
1	End cap for 282-128/281-418 above	Wago	282-311
1	Fuse TB 1/4"x1 1/4" w/led ind, 24VDC		
<b>PLC</b>			
1	Micrologix 1000 with analog input, 24VDC	Allen Bradley	1761-BWBL20- 5A
1	Micro PV300		
<b>Power Supply</b>			
1	120VAC to 24VDC power supply,	Phoenix Contact	2938840
<b>Transducer</b>			
1	Pressure transducer, .5%, vented gauge, 4-20mA, 1/4"	Pressure Systems	28-142-4-0065
<b>Selector switch</b>			
2	3 position maintained selector SW, no blocks	Sq D	9001-KS43B
4	Contact blocks 1-NO/1-NC	Sq D	9001-KA1
<b>Contactors</b>			
1	Definite Purpose contactor, 2 Pole, 120V coil, 25A FLA	Sq D	8910 DPA22

# Dimensions and Layout

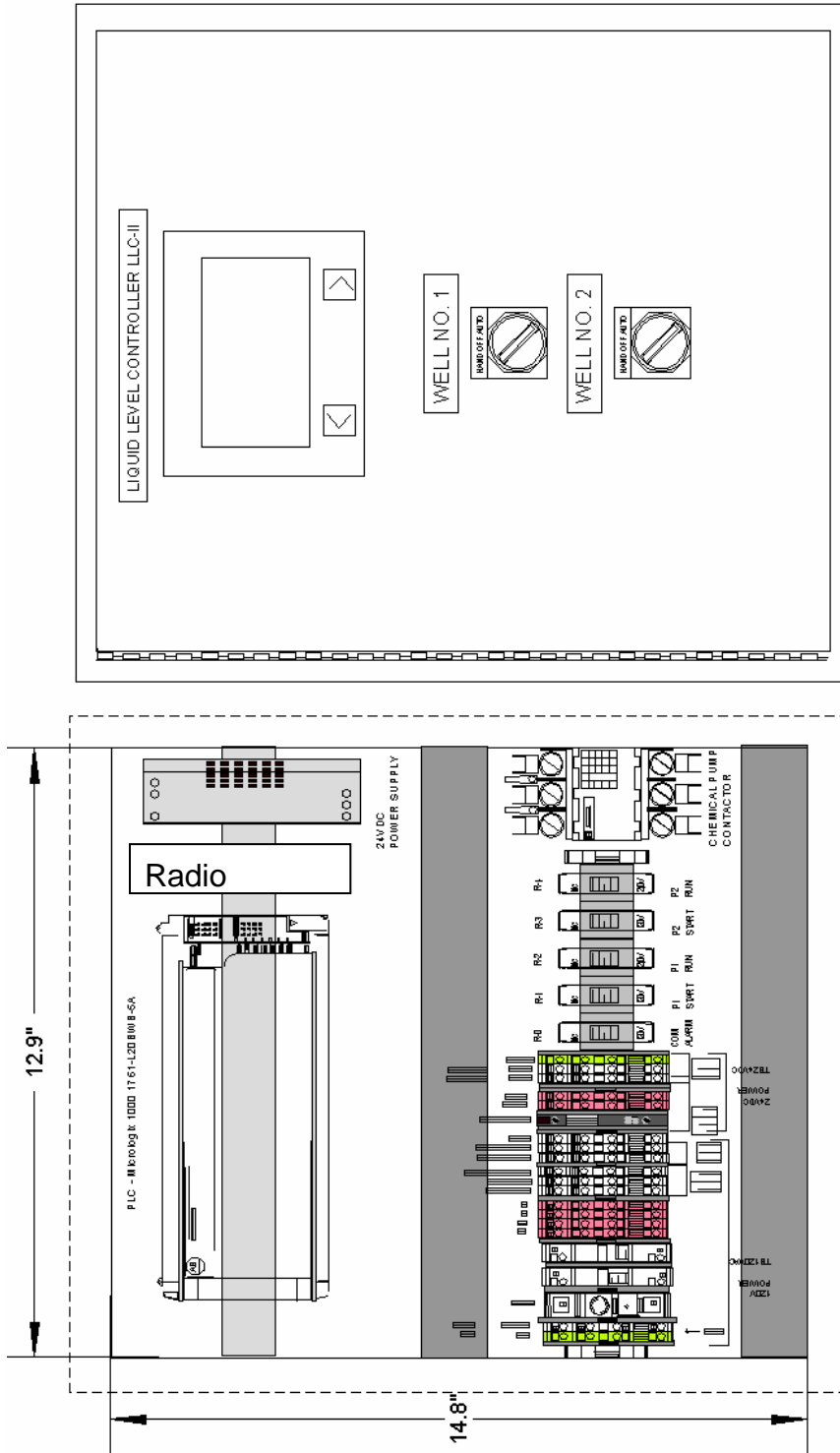

LLC-II LEVEL CONTROLLER FOR TWO PUMPS



# Options

## Telemetry Option for LLC

Either the LLC-I or the LLC-II can be augmented to become a telemetry master RTU. Function and programming is essentially the same. Instead of connecting additional pumps to the process through wiring, radio telemetry is used to control a remote pump. Set-up and monitoring are the same as with the non-telemetry controller. The main difference is the presence of an RF Fail alarm to indicate to the user when the radio signal has been lost or compromised.

## Telemetry Option for Slave Unit

In addition to the option of adding a radio to the LLC, a slave unit can be purchased in order to have a way to get the radio signal to the remote pump. A radio slave unit is shown on page 26.

This unit has run, fail and elapsed time indicators as well. In addition, the unit has a selector switch enabling the operator to choose HAND-OFF-AUTO modes.

Lastly, there is a LOCAL-REMOTE switch which allows the operator to choose between local and remote auto modes. For example if the HOA selector is in AUTO mode and the LOCAL/REMOTE switch is in remote mode, the master controller will control the pump based on tank level setpoints. If the LOCAL/REMOTE switch is turned to local the pump can be controlled by a local device such as a timer.

Note that there is a timer in the telemetry slave. This Off-Delay timer keeps the pump running for a short time after the radio signal calls for the well to stop. The purpose of this is to prevent cycling if the radio signal is weak. A brief interruption in the radio signal will not be able to shut the pump off.

# TELEMETRY RTU SLAVE

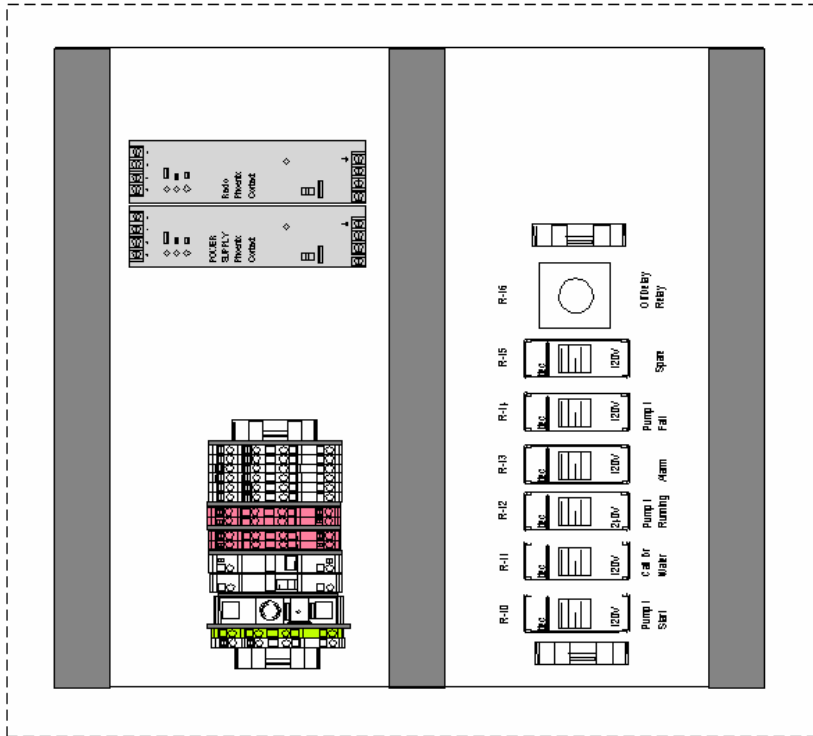
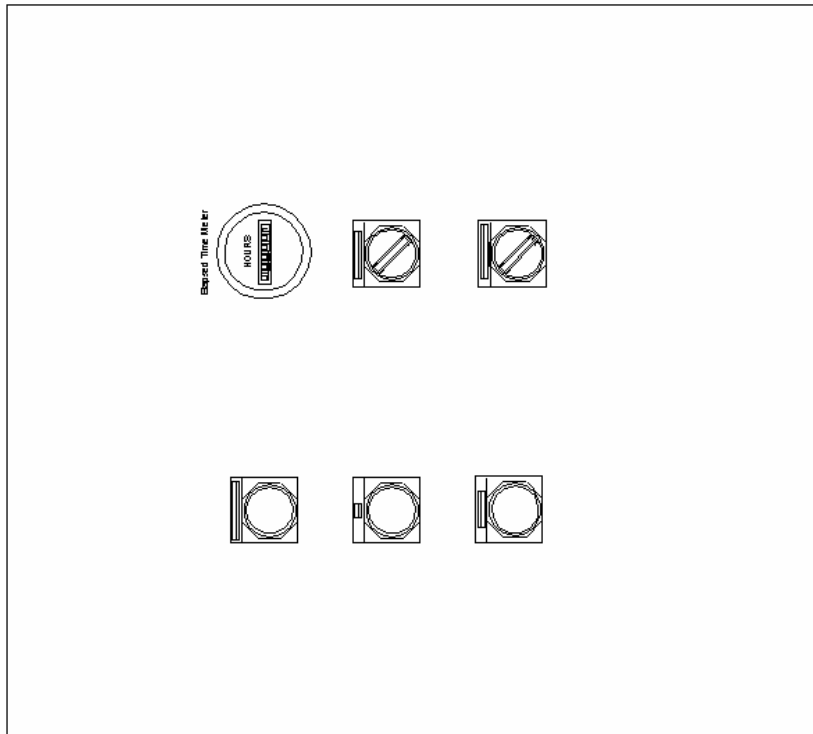

## **Alarm Beacon**

The existence of a common alarm relay at the LLC (and also at the Slave RTU if there is one) allows connection to an alarm output. Most commonly this is an alarm beacon to indicate to the user when any of a number of alarm conditions occur including:

- Low or High Tank
- PLC Fault
- Transducer Failure
- Pump Failure
- Radio Signal Failure (for telemetry options only)

The alarm beacon can be shut off by acknowledging the alarm condition. This is done by pressing the “F2” button to get to the alarm screen, and then the “F2” button again to acknowledge the alarms.

## **Surge Protection**

The LLC units, as well as Telemetry slave units, have built in surge protection in the form of an air gap surge protector and a silicon avalanche diode surge protector. It is recommended that additionally the Pumphouse be protected by a surge protector such as the Joslyn Z2-175. This unit has a visible window to indicate if the unit is ok.

# Wiring Diagrams and Terminations

**RADIO TELEMETRY  
SLAVE RTU  
TERMINAL BLOCK LAYOUT  
WELL 1**

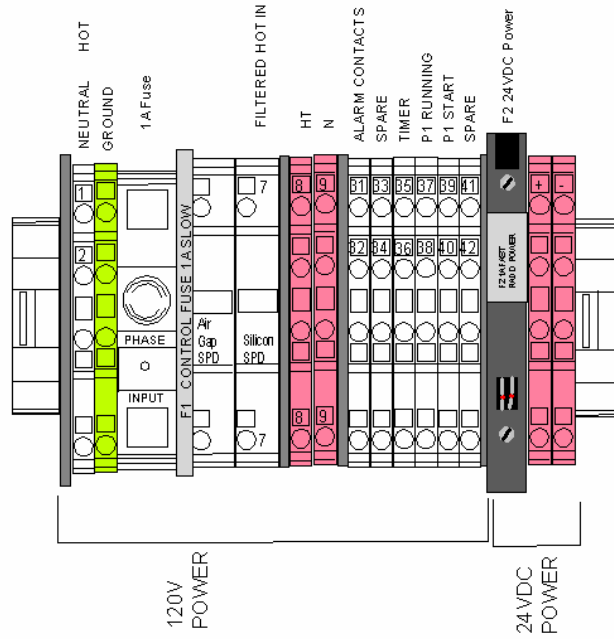

**LIQUID LEVEL CONTROLLER/  
MASTER RTU  
TERMINAL BLOCK LAYOUT  
WELL 2**

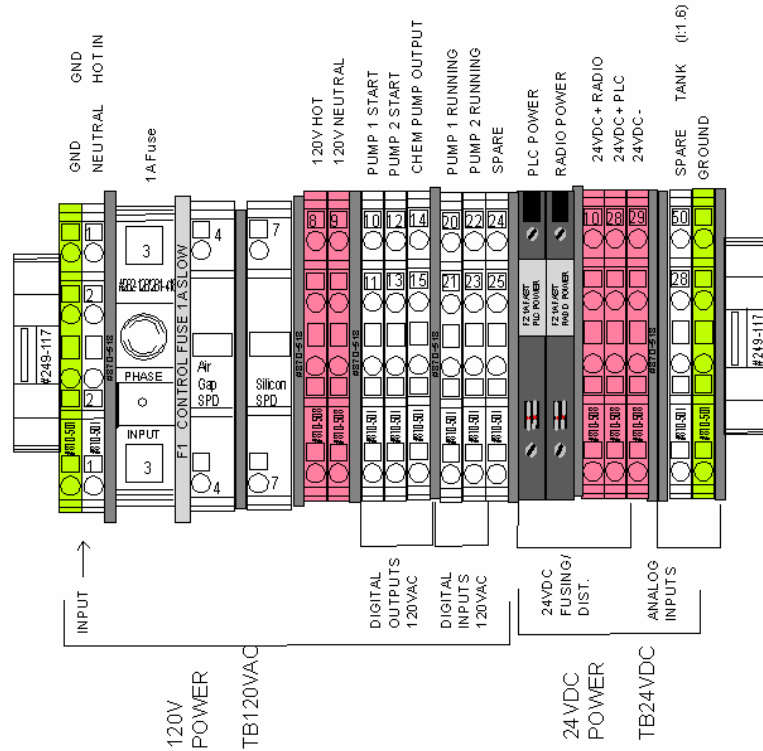

AB  
1761-L20BWB-5A  
MICROLOGIX  
12-PT SINK IN, 8-PT RELAY OUT W/ ANALOG

24VDC  
RED

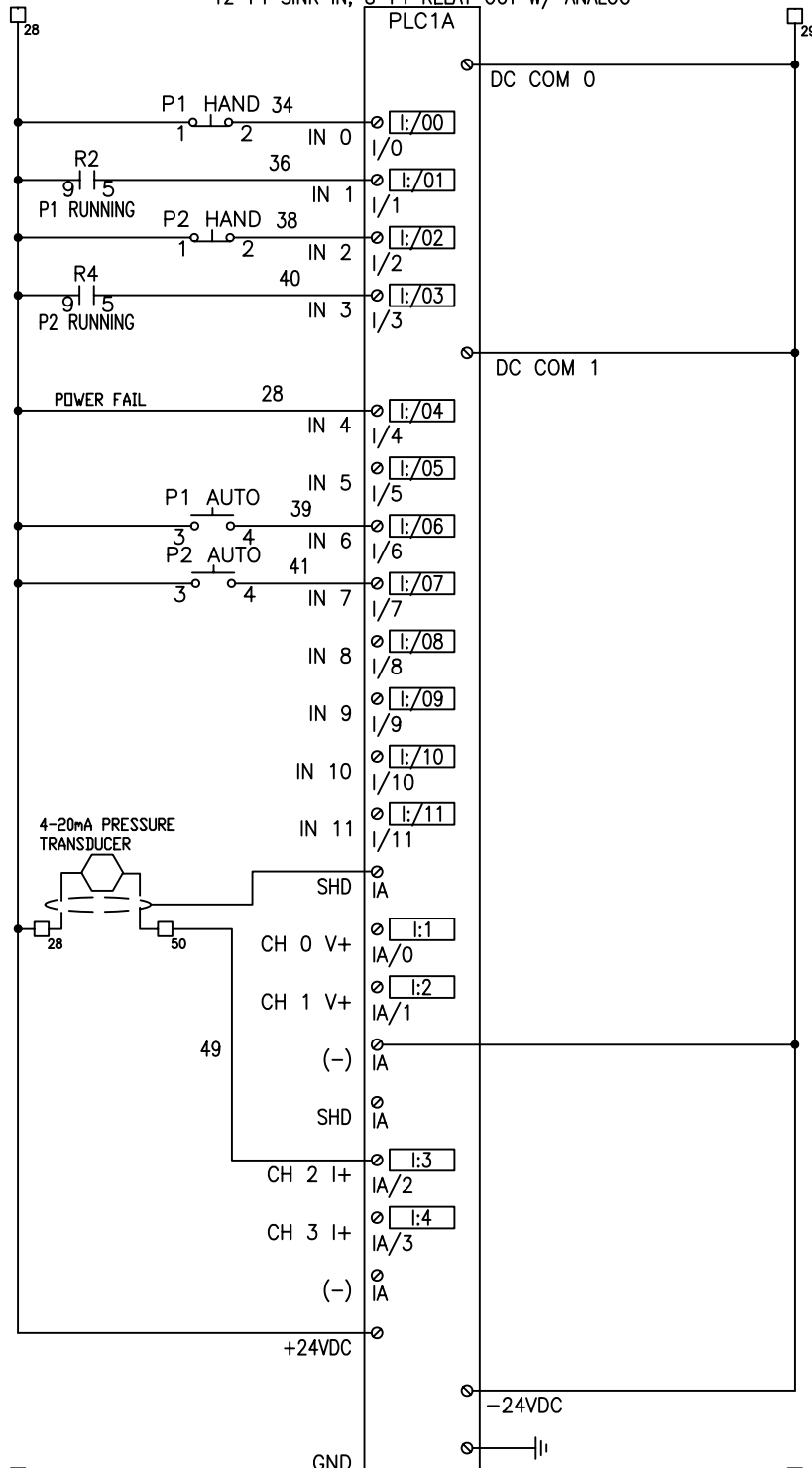

120VAC  
BLACK/  
WHITE

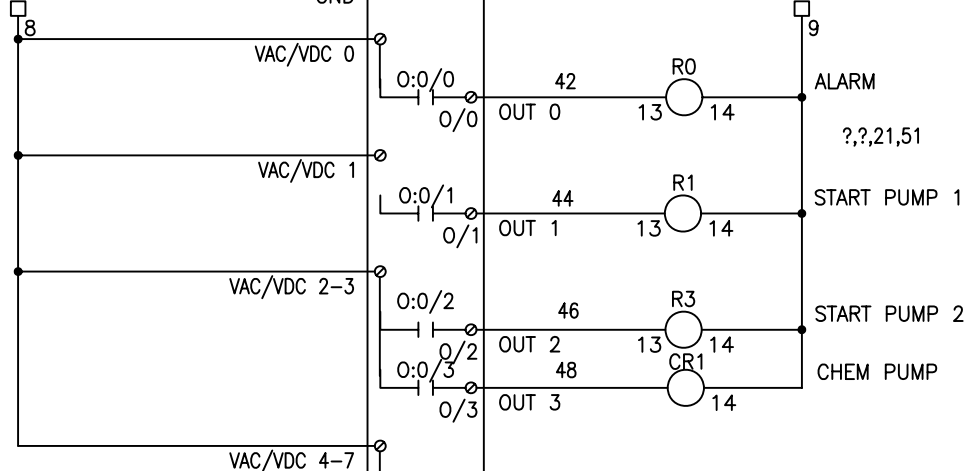

# LLC-2

ALL WIRING #16 STRANDED UNLESS OTHERWISE NOTED.  
 24VDC WIRING IS RED. 120 AND 240V WIRING IS BLACK (WHITE FOR NEUTRAL)

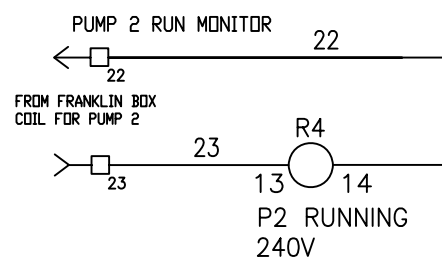
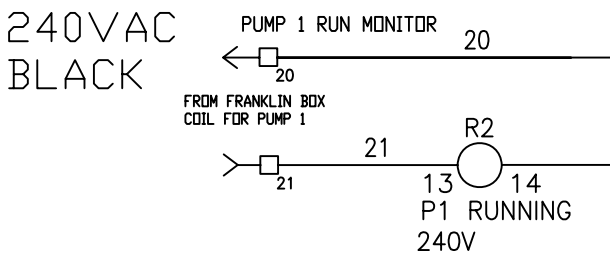
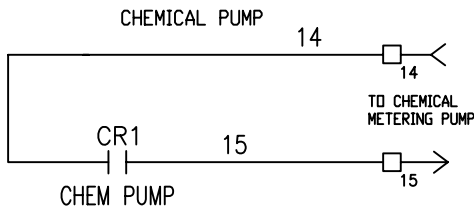
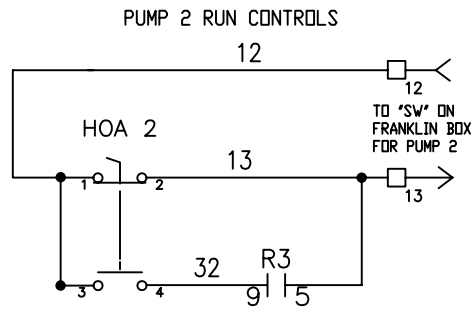
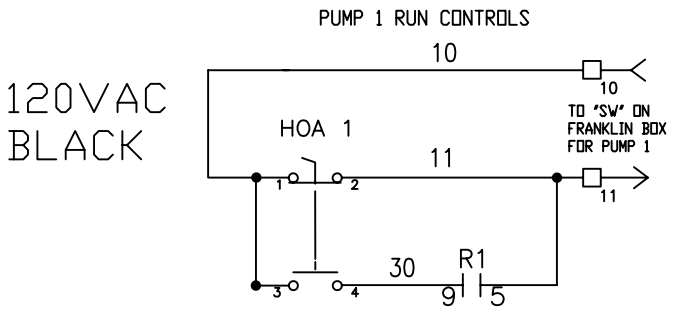
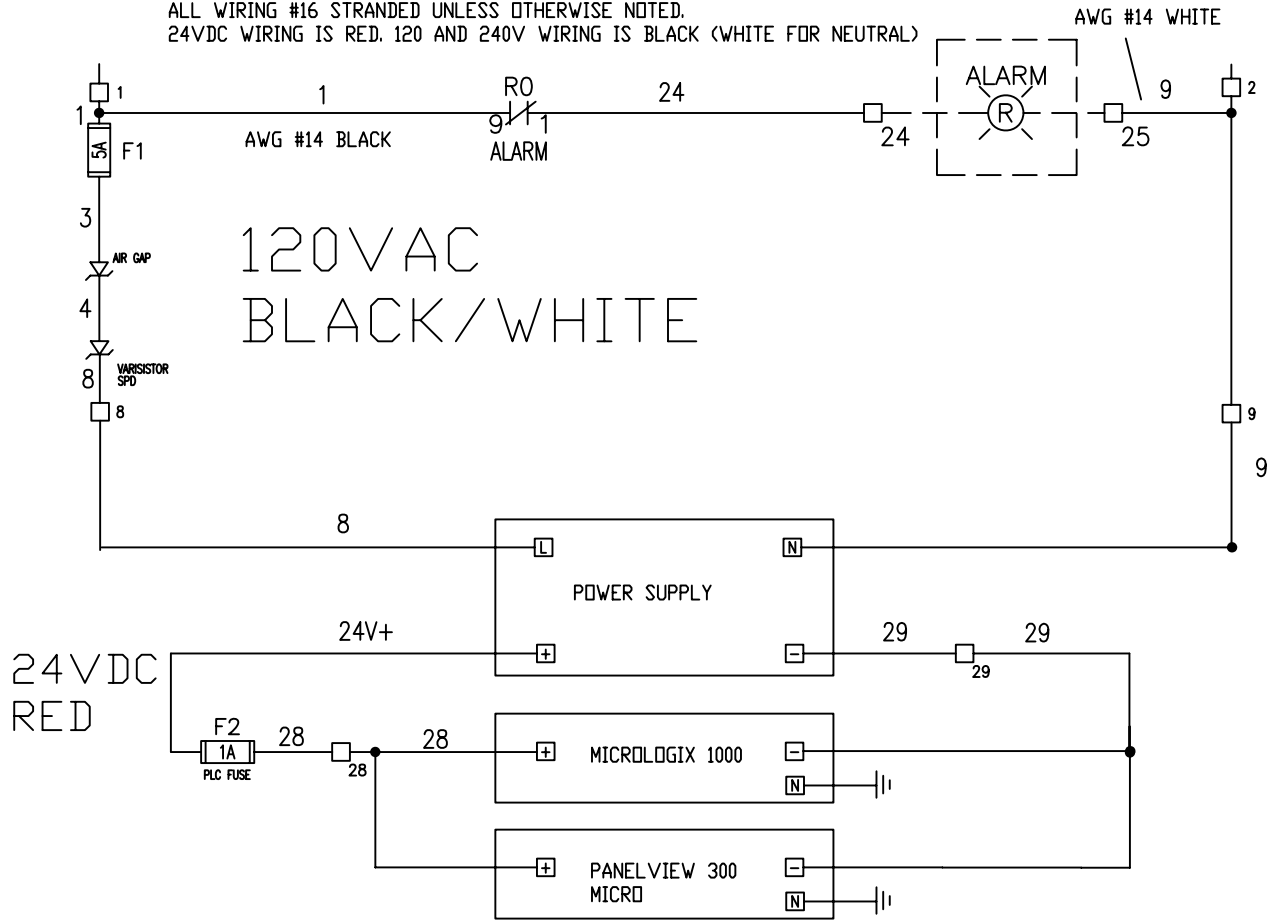

© Paragon Electric, Inc.  
Albuquerque, New Mexico  
505 265-5883  
[www.paragon-electric.com](http://www.paragon-electric.com)

