

URB100CC

High-Speed Belt-Driven Rotation Stage



Newport®

Experience | Solutions

USER'S MANUAL

Precision Motion – **Guaranteed™**

Warranty

Newport Corporation warrants this product to be free from defects in material and workmanship for a period of 1 year from the date of shipment. If found to be defective during the warranty period, the product will either be repaired or replaced at Newport's discretion.

To exercise this warranty, write or call your local Newport representative, or contact Newport headquarters in Irvine, California. You will be given prompt assistance and return instructions. Send the instrument, transportation prepaid, to the indicated service facility. Repairs will be made and the instrument returned, transportation prepaid. Repaired products are warranted for the balance of the original warranty period, or at least 90 days.

Limitation of Warranty

This warranty does not apply to defects resulting from modification or misuse of any product or part.

CAUTION

Warranty does not apply to damages resulting from:

- **Incorrect usage:**
 - **Load on the stage greater than maximum specified load.**
 - **Carriage speed higher than specified speed.**
 - **Improper grounding.**
 - **Connectors must be properly secured.**
 - **When the load on the stage represents an electrical risk, it must be connected to ground.**
 - **Excessive or improper cantilever loads.**
- **Modification of the stage or any part thereof.**



CAUTION

Please return equipment in the original (or equivalent) packing.

You will be responsible for damage incurred from inadequate packaging if the original packaging is not used.

This warranty is in lieu of all other warranties, expressed or implied, including any implied warranty of merchantability or fitness for a particular use. Newport Corporation shall not be liable for any indirect, special, or consequential damages.

No part of this manual may be reproduced or copied without the prior written approval of Newport Corporation.

This manual has been provided for information only and product specifications are subject to change without notice. Any changes will be reflected in future printings.

Table of Contents

Warranty	ii
EC Declaration of Conformity.....	v
Definitions and Symbols.....	vi
Warnings	vii
Cautions	viii
<hr/>	
1.0 — Introduction.....	1
<hr/>	
2.0 — Description	2
2.1 Design Details	2
<hr/>	
3.0 — Characteristics.....	3
3.1 Definitions	3
3.2 Mechanical Specifications	4
3.3 Load Specification Definitions.....	4
3.4 Load Characteristics and Stiffness	4
3.5 Stage Weights	5
<hr/>	
4.0 — Drive	5
4.1 DC-Motor Drive.....	5
<hr/>	
5.0 — Motor	6
5.1 UE34CC Motor Characteristics.....	6
5.2 Command Signals for the DC-Motor	6
5.3 Sensor Position.....	6
5.4 Feedback Signal Position	7
5.5 Pinouts.....	7
<hr/>	
6.0 — Connection to Newport Controllers.....	9
6.1 Warnings on Controllers	9
6.2 Connection.....	10
6.3 Cables	10
6.4 MSCABLE-3 Cable.....	10
<hr/>	
7.0 — Connection to Non-Newport Electronics	11
7.1 Connections.....	11
<hr/>	
8.0 — Disabling of Limit Switches	12
<hr/>	

9.0 — Dimensions	12
-------------------------------	----

10.0 — Maintenance	13
---------------------------------	----

10.1 Maintenance	13
------------------------	----

10.2 Repair	13
-------------------	----

10.3 Calibration	13
------------------------	----

Service Form	15
--------------------	----

EC Declaration of Conformity

URB100CC



Newport®

Experience | Solutions

EC Declaration of Conformity

following Annex II-1A
of Directive 2006/42/EC on machinery

The manufacturer:

MICRO-CONTROLE Spectra-Physics,
9 rue du Bois Sauvage
F-91055 Evry FRANCE

Hereby declares that the machinery:

- Description: " URB100CC "
- Function: High-Speed Belt-Driven Rotation Stage
- Models: URB100CC

– the technical file of which was compiled by:

Mr Dominique DEVIDAL, Quality Director,
MICRO-CONTROLE Spectra-Physics, Zone Industrielle - B.P.29
F-45340 Beauce La Rolande France

- complies with all the relevant provisions of the Directive 2006/42/EC on machinery.
- complies with all the relevant provisions of the Directive 2014/30/EU relating to electro-magnetic compatibility.

– was designed and built in accordance with the following harmonised standards:

- NF EN 61326-1:2013 « Electrical equipment for measurement, control and laboratory use – EMC requirements – Part 1: General requirements »
- NF EN 55011:2010/A1:2011 Class A

– was designed and built in accordance with the following other standards:

- NF EN 61000-4-2
- NF EN 61000-4-3
- NF EN 61000-4-4
- NF EN 61000-4-5
- NF EN 61000-4-6

ORIGINAL DECLARATION

Done in Beauce La Rolande on 26 June 2015
Dominique DEVIDAL
Quality Director

DC1-EN rev:A

Definitions and Symbols

The following terms and symbols are used in this documentation and also appear on the product where safety-related issues occur.

General Warning or Caution



The exclamation symbol may appear in warning and caution tables in this document. This symbol designates an area where personal injury or damage to the equipment is possible.

The following are definitions of the Warnings, Cautions and Notes that may be used in this manual to call attention to important information regarding personal safety, safety and preservation of the equipment, or important tips.



WARNING

Warning indicates a potentially dangerous situation which can result in bodily harm or death.



CAUTION

Caution indicates a potentially hazardous situation which can result in damage to product or equipment.

NOTE

Note indicates additional information that must be considered by the user or operator.

European Union CE Mark



The presence of the CE Mark on Newport Corporation equipment means that it has been designed, tested and certified as complying with all applicable European Union (CE) regulations and recommendations.

Warnings and Cautions



ATTENTION

This stage is a Class A device. In a residential environment, this device can cause electromagnetic interference. In this case, suitable measures must be taken by the user.

Warnings



WARNING

The motion of objects of all types carries potential risks for operators. Ensure the protection of operators by prohibiting access to the dangerous area and by informing the personnel of the potential risks involved.

WARNING

Do not use this stage when its motor is emitting smoke or is unusually hot to the touch or is emitting any unusual odor or noise or is in any other abnormal state.

Stop using the stage immediately, switch off the motor power and then disconnect the electronics power supply.

After checking that smoke is no longer being emitted contact your Newport service facility and request repairs. Never attempt to repair the stage yourself as this can be dangerous.

WARNING

Make sure that this stage is not exposed to moisture and that liquid does not get into the stage.

Nevertheless, if any liquid has entered the stage, switch off the motor power and then disconnect the electronics from power supply.

Contact your Newport service facility and request repairs.

WARNING

Do not insert or drop objects into this stage, this may cause an electric shock, or lock the drive.

Do not use this stage if any foreign objects have entered the stage. Switch off the motor power and then disconnect the electronics power supply.

Contact your Newport service facility for repairs.

WARNING

Do not place this stage in unstable locations such as on a wobbly table or sloping surface, where it may fall or tip over and cause injury.

If this stage has been dropped or the case has been damaged, switch off the motor power and then disconnect the electronics power supply.

Contact your Newport service facility and request repairs.

WARNING

Do not attempt to modify this stage; this may cause an electric shock or downgrade its performance.

WARNING

Do not exceed the usable depth indicated on the mounting holes (see section “Dimensions”). Longer screws can damage the mechanics or cause a short-circuit.

Cautions

CAUTION

Do not place this stage in a hostile environment such as X-Rays, hard UV,... or in any vacuum environment.

CAUTION

Do not place this stage in a location affected by dust, oil fumes, steam or high humidity. This may cause an electric shock.

CAUTION

Do not leave this stage in places subject to extremely high temperatures or low temperatures. This may cause an electric shock.

- Operating temperature: +10 to +35 °C
 - Storage temperature: -10 to +40 °C (in its original packaging)
-

CAUTION

Do not move this stage if its motor power is on.

Make sure that the cable to the electronics is disconnected before moving the stage. Failure to do so may damage the cable and cause an electrical shock.

CAUTION

Be careful that the stage is not bumped when it is being carried. This may cause it to malfunction.

CAUTION

When handling this stage, always unplug the equipment from the power source for safety.

CAUTION

When the carriage is in its end-of-run position, it is strongly recommended not to go beyond this point as this may damage the stage mechanism.

CAUTION

Contact your Newport service facility to request cleaning and specification control every year.

High-Speed Belt-Driven Rotation Stage

URB100CC

1.0 Introduction

This manual provides operating instructions for the URB100CC rotation stage.

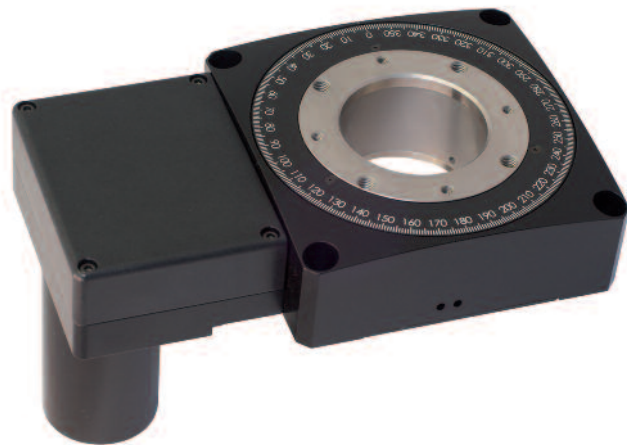

URB100CC rotation stage.

RECOMMENDATION

We recommend you read carefully the chapter “Connection to electronics” before using the URB100CC rotation stage.

2.0 Description

The URB100CC rotation stage is based on our popular URS series, but features a belt drive instead of a worm gear. The belt drive offers significantly higher rotation speeds of up to 720 °/s without sacrificing life time expectancies. Typical applications are LIDAR, 3D imaging, or film thickness measurements of semiconductor wafers. Common to these applications are fast rotations over larger angles or continuous spinning at very high duty cycles and with high precision requirements with regards to wobble, angular repeatability, and speed stability.

Like the URS series, the URB100CC features a proprietary 4-contact point ball bearing. The unique, 2-piece design provides exceptional stiffness, high reliability and outstanding wobble and eccentricity. The enhanced low-profile package supplies easy top down mounting options and is mechanically compatible with our ILS series of linear stages (note, motor protrudes the lower surface of the stage).

Position feedback is provided by a motor mounted 2000 cts/rev. rotary encoder. To minimize the effects of drive chain Hysteresis impacting repeatability, positions should be always approached from the same direction of motion.

2.1 Design Details

Based material	Hardened steel with Aluminum body
Bearings	Large diameter 4-contact point ball bearing
Drive mechanism	Belt drive with 18:1 reduction ratio
Feedback	Motor mounted rotary encoder, 2,000 cts/rev, index pulse
Limit switches	Two independently adjustable optical limit switches, enabled/disabled by external switch
Origin	Optical, fixed at position 0°, Typical 0.015° repeatability
Motor	UE34CC DC servo motor
Cable	3 m long cable included



NOTE

This product complies with the RoHS directive (Restriction of Hazardous Substances).

3.0 Characteristics

3.1 Definitions

Specifications of our products are established in reference to ISO 230 standard part II “Determination of accuracy and repeatability of positioning numerically controlled axes”.

This standard gives the definition of position uncertainty which depends on the 3 following parameters:

(Absolute) Accuracy

Difference between ideal position and real position.

On-Axis Accuracy

Difference between ideal position and real position after the compensation of linear errors.

Linear errors include: cosine errors, inaccuracy of screw or linear scale pitch, angular deviation at the measuring point (Abbe error) and thermal expansion effects. All Newport motion electronics can compensate for linear errors.

The relation between absolute accuracy and on-axis accuracy is as follows:

$$\text{Absolute Accuracy} = \text{On-Axis Accuracy} + \text{Correction Factor} \times \text{Travel}$$

Repeatability

Ability of a system to achieve a commanded position over many attempts.

Reversal Value (Hysteresis)

Difference between actual position values obtained for a given target position when approached from opposite directions.

Minimum Incremental Motion (MIM or Sensitivity)

The smallest increment of motion a device is capable of delivering consistently and reliably.

Resolution

The smallest increment that a motion device can theoretically move and/or detect. Resolution is not achievable, whereas MIM, is the real output of a motion system.

Eccentricity

Displacement of the geometric center of a rotation stage from the rotation axis in the plane defined by bearings.

Wobble

Tilt of rotation axis during rotation of a stage, measured on a reference surface.

The testing of on-axis accuracy, repeatability, and reversal error are made systematically with test equipment in an air-conditioned room (20^{±1} °C).

A linear cycle with 21 data points on the travel and 4 cycles in each direction gives a total of 164 points.

Guaranteed Specifications

Guaranteed maximum performance values are verified per Newport's A167 metrology test procedure. For more information, please consult the metrology tutorial section in the Newport catalog or at www.newport.com

3.2 Mechanical Specifications



Travel Range (°)	360 continuous ⁽¹⁾
Minimum Incremental Motion (°)	0.02
Uni-directional Repeatability ⁽²⁾ (°)	0.015
Bi-directional Repeatability ⁽³⁾ (°)	0.115 or ±0.0575
Absolute Accuracy ⁽³⁾ (°)	0.2 or ±0.1
Maximum Speed (°/s)	720
Maximum acceleration (°/s ²)	1300 (with of 0.025 kg.m ² inertia)
Wobble ⁽³⁾ (µrad)	50 or ±25
Eccentricity ⁽³⁾ (µm)	3 or ±15
MTBF	20000 h at 25% load and with a 30% duty cycle

¹⁾ With disabled limit switches.

²⁾ To minimize drive chain hysteresis affecting repeatability, Newport recommends always approaching positions from the same direction of motion.

³⁾ Shown are peak to peak, guaranteed specifications or ±half the value as sometimes shown. For the definition of typical specifications which are about 2X better than the guaranteed values, visit www.newport.com for the Motion Control Metrology Primer



CAUTION

To reach specifications stated, stages must be fixed on a plane surface with a flatness of 5 µm.

3.3 Load Specification Definitions

Normal Load Capacity (Cz)

Maximum load a rotation stage can move while maintaining specifications.

This value is given with speed and acceleration specified for each rotation stage, and with a load perpendicular to bearings.

Off-Centered Load (Q)

Maximum cantilever-load a rotation stage can move: $Q \leq Cz \div (1 + D/a)$

D: Cantilever distance.

a: Construction parameter.

3.4 Load Characteristics and Stiffness

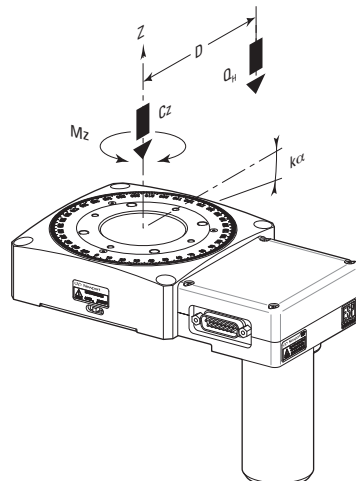

Cz, Normal centered load capacity (N)	100
Kca, Transversal compliance (µrad/Nm)	10
Mz, Maximum torque (Nm)	±0.6
Jz, Maximum inertia (kg.m ²)	0.025
Q, Off-center load (N)	$Q \leq Cz \div (1 + D/35)$
Where D = Cantilever distance (mm)	

3.5 Stage Weight

The stage weight below is the value of the rotation stage without the cable.

	Weight [lb (kg)]
URB100CC	4.0 (1.8)
3-meter MSCABLE-3 Cable	0.66 (0.3)

4.0 Drive

4.1 DC-Motor Drive

	Resolution (°)	Speed (°/s)	Motor
URB100CC	0.01	720	UE34CC

5.0 Motor

5.1 UE34CC Motor Characteristics

Motor	Nominal Voltage (V)	Max. RMS Current (A)	Max. Peak Current (A)	Resistance (Ω)	Inductance (mH)
UE34CC	20	1.0	2.0	2.52	0.51

5.2 Command Signals for the DC-Motor

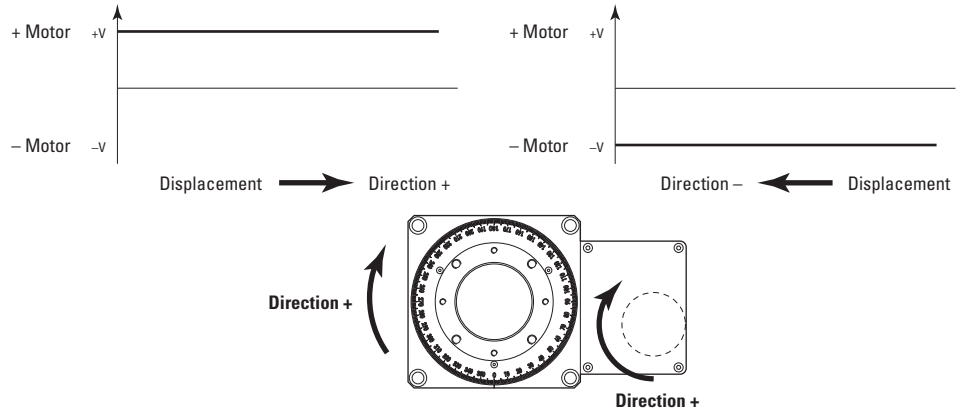

In the above drawings, + Motor signal is referred to - Motor signal.

- ① When the stage moves in + Direction, the + Motor voltage is higher than - Motor voltage.
- ② When the stage moves in - Direction, the + Motor voltage is lower than - Motor voltage.

5.3 Sensor Position

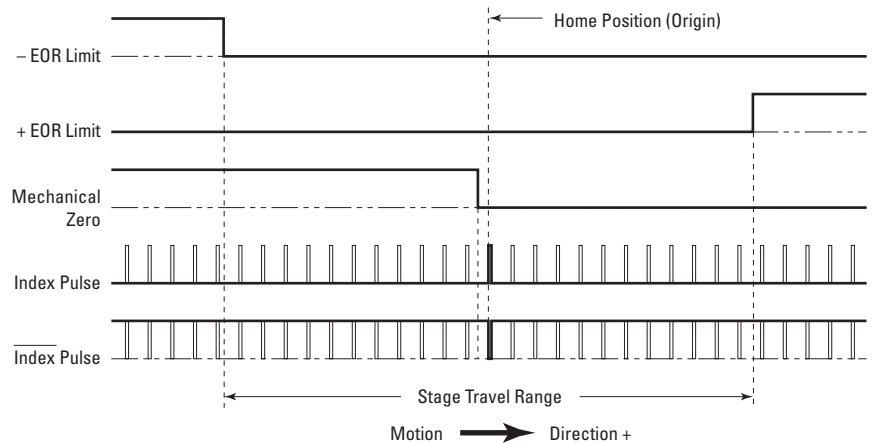

End-of-Run and Mechanical Zero are 5 V open collector type.

The Index Pulse provides a repeatable Home Position at ± 1 step.



CAUTION

“End-of-Run” and “Mechanical Zero” are active signals and should not be connected to any other source.

5.4 Feedback Signal Position

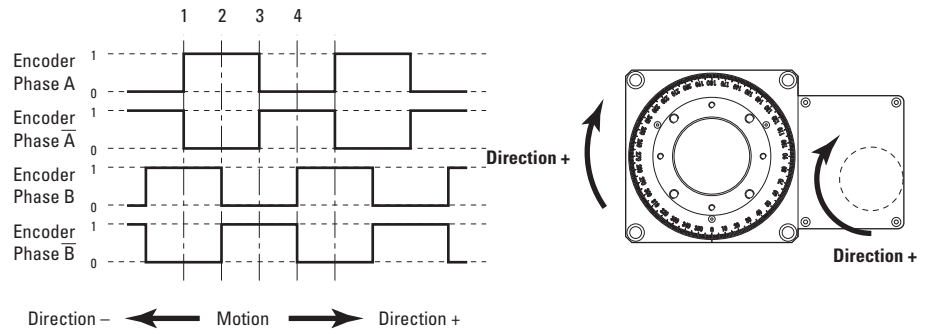

The incremental sensor consists of an optical scale and an encoder head. When the carriages of the stage move, the encoder head generates square signals in quadrature, sent to pins #19, #20, #23 and #24 of the SUB-D25 connector.

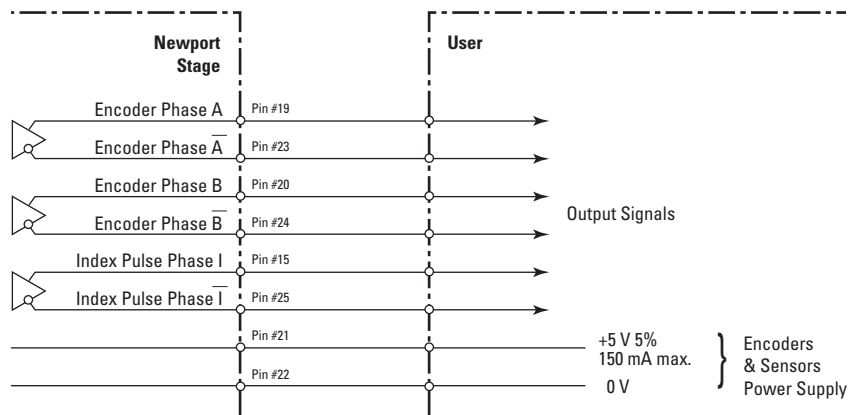

“Encoder” and “Index Pulse” are “differential pair” (type RS-422) type output signals. Using these signals permits a high immunity to noise. Emission circuits generally used by Newport are 26LS31 or MC3487. Reception circuits to use are 26LS32 or MC3486.

5.5 Pinouts

The SUB-D15 connection for the URB100CC rotation stage is given in the following table:

URB100CC UE34CC	
1	N.C.
2	+ Motor
3	Mechanical Zero
4	- End-of-Run
5	0 V
6	Encoder Phase /A
7	Encoder Phase /B
8	/Index Pulse
9	N.C.
10	- Motor
11	+ End-of-Run
12	+5 V
13	Encoder Phase A
14	Encoder Phase B
15	Index Pulse

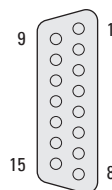

The SUB-D25 connection at the end of the cable is given in the following table:

URB100CC			
UE34CC			
1	N.C.	14	Shield Ground
2	N.C.	15	Index Pulse
3	N.C.	16	0 V logic
4	N.C.	17	+ End-of-Run
5	+ Motor	18	- End-of-Run
6	+ Motor	19	Encoder Phase A
7	- Motor	20	Encoder Phase B
8	- Motor	21	+5 V
9	N.C.	22	0 V Encoder
10	N.C.	23	Encoder Phase /A
11	N.C.	24	Encoder Phase /B
12	N.C.	25	/Index Pulse
13	Mechanical Zero		

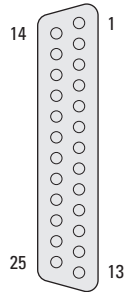

6.0 Connection to Newport Controllers

6.1 Warnings on Controllers

Controllers are intended for use by qualified personnel who recognize shock hazards and are familiar with safety precautions required to avoid possible injury. Read the controller user's manual carefully before operating the instrument and pay attention to all written warnings and cautions.

WARNING

Disconnect the power plug under the following circumstances:

- If the power cord or any attached cables are frayed or damaged in any way.
- If the power plug is damaged in any way.
- If the unit is exposed to rain, excessive moisture, or liquids are spilled on the unit.
- If the unit has been dropped or the case is damaged.
- If you suspect service or repair is required.
- Whenever you clean the electronics unit.

CAUTION

To protect the unit from damage, be sure to:

- Keep all air vents free of dirt and dust.
- Keep all liquids away from the unit.
- Do not expose the unit to excessive moisture (85% humidity).
- Read this manual before using the unit for the first time.



WARNING

All attachment plug receptacles in the vicinity of this unit are to be of the grounding type and properly polarized.

Contact your electrician to check your receptacles.

WARNING

This product is equipped with a 3-wire grounding type plug.

Any interruption of the grounding connection can create an electric shock hazard.

If you are unable to insert the plug into your wall plug receptacle, contact your electrician to perform the necessary alterations to ensure that the green (green-yellow) wire is attached to earth ground.

WARNING

This product operates with voltages that can be lethal.

Pushing objects of any kind into cabinet slots or holes, or spilling any liquid on the product, may touch hazardous voltage points or short out parts.

6.2 Connection

On each stage is represented a label which indicates its name and its serial number.



WARNING

Always turn the controller's power OFF before connecting to a stage.

Stages may be connected to the rear panel motor connectors any time prior to power-up with the supplied cable assemblies.

NOTE



These stages are **ESP compatible**. Enhanced System Performance is Newport's exclusive technology that enables Newport ESP motion controllers to recognize the connected Newport ESP stage and upload the stage parameters. This ensures that the user can operate the motion system quickly and safely.

6.3 Cables

Our stages are delivered with a **MSCABLE-3** 3-meter cable. This cable is equipped with SUB-D15F and SUB-D25M connectors so it can be directly connected to our controllers/drivers.

6.4 MSCABLE-3 Cable

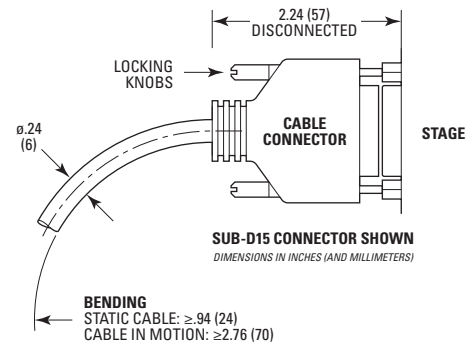

WARNING

This cable is shielded correctly. For a correct operation, make sure to lock connectors (ground continuity provided by the cable).

For applications where the standard 3-meter cable (**MSCABLE-3**) included with your stage is not adequate, Newport offers a 10-m longer length cable (**MSCABLE-10**) designed to ensure the integrity of your positioning application.

These cables are specially shielded and terminated with Newport's standard SUB-D15 and SUB-D25 connectors.



WARNING

Keep the motor cables at a safe distance from other electrical cables in your environment to avoid potential cross talk.

7.0 Connection to Non-Newport Electronics

7.1 Connections

WARNING

Newport is not responsible for malfunction or damage to a URB100CC stage when it is used with non-Newport controllers.

WARNING

Newport guarantees “ C ” compliance of the URB100CC stage only if they are used with Newport cables and controllers.

Nevertheless, the figure below shows the wiring when a URB100CC stage is used with non-Newport controllers.

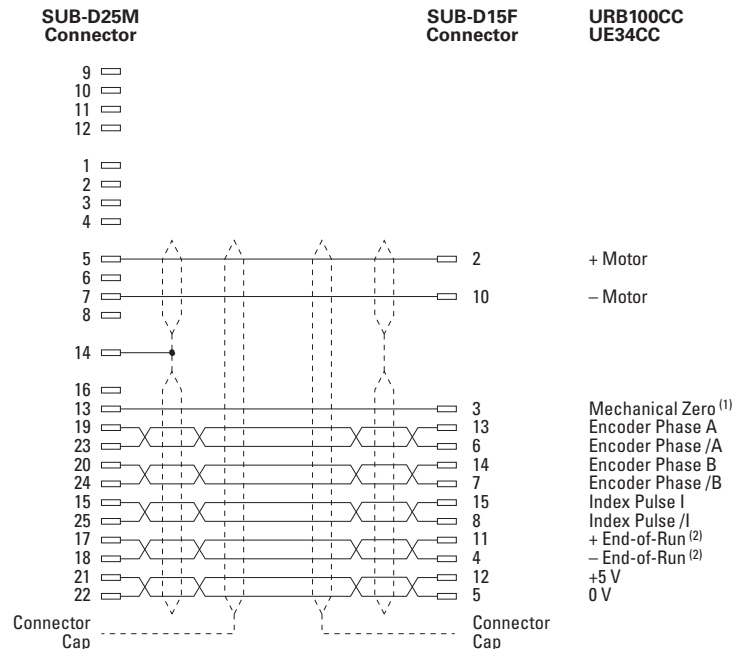

⁽¹⁾ The Mechanical Zero logic signal is open collector type. It supports until 30 V and 10 mA.

⁽²⁾ Open collector type with a 5.6 V protective Zener diode.

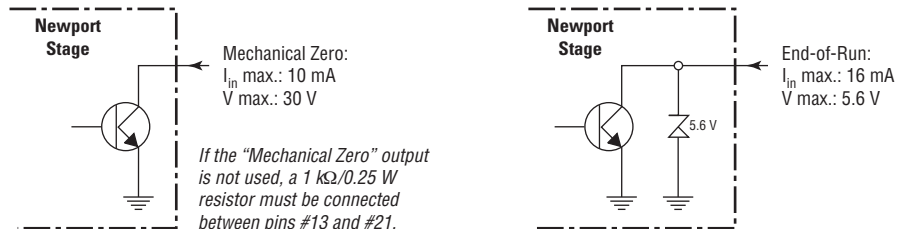

“Encoder” and “Index Pulse” are “differential pair” (type RS-422) type output signals. Using these signals permits a high immunity to noise. Emission circuits generally used by Newport are 26LS31 or MC3487. Reception circuits to use are 26LS32 or MC3486.

8.0 Disabling of Limit Switches

The URB100CC stage is equipped with a $\pm 160^\circ$ optical limit switch which can be disabled for continuous 360° rotation.

NOTE

On request, the limit switch can be set in factory at the desired position. Please contact our sales engineers.

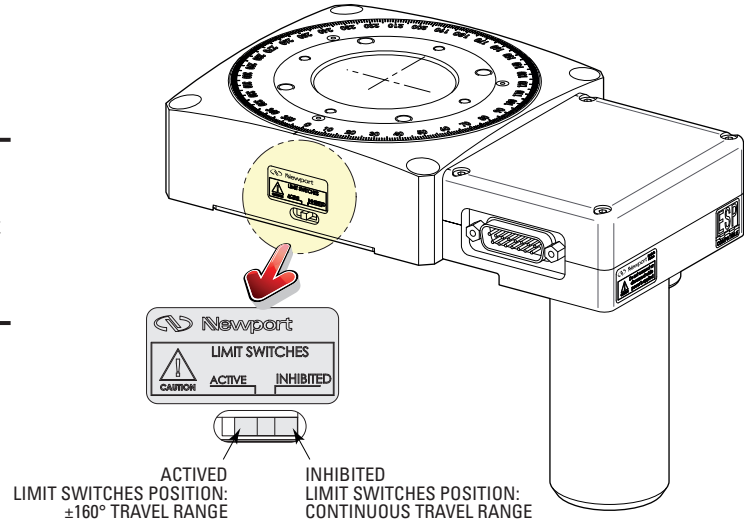

9.0 Dimensions

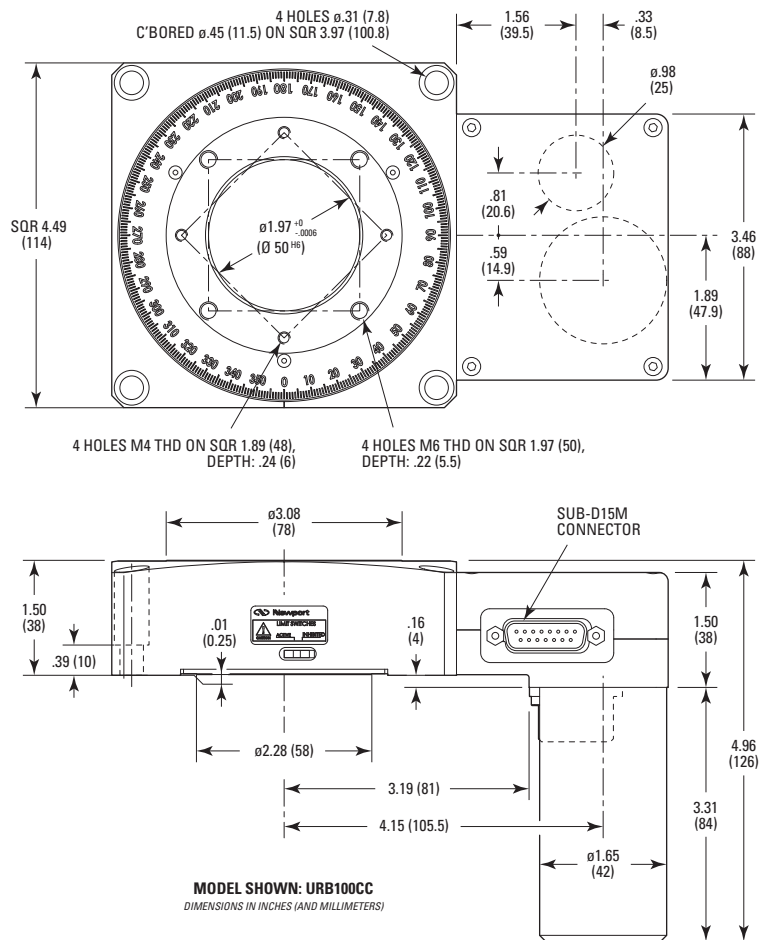

10.0 Maintenance

RECOMMENDATION

It is recommended to contact our After Sales Service which will know to define the appropriate maintenance for your application.

10.1 Maintenance

The URB100CC stage requires no particular maintenance. Nevertheless, this is a precision mechanical device that must be kept and operated with caution.

PRECAUTIONS

The URB100CC stage must be used or stocked in a clean environment, without dust, humidity, solvents or other substances.

RECOMMENDATION

It is recommended to return your URB100CC stage to Newport's After Sales Service after every 2000 hours of use for lubrication.

If your stage is mounted on a workstation and cannot be easily removed, please contact Newport's After Sales Service for further instructions.

10.2 Repair

CAUTION



Never attempt to disassemble a component of the stage that has not been covered in this manual.

To disassemble a non specified component can cause a malfunction of the stage.

If you observe a malfunction in your stage, please contact us immediately to arrange for a repair.

CAUTION



Any attempt to disassemble or repair a stage without prior authorization will void your warranty.

10.3 Calibration

CAUTION



It is recommended to return your URB100CC stage to Newport once a year for recalibration to its original specifications.

Service Form

Your Local Representative

Tel.: _____

Fax: _____

Name: _____

Return authorization #: _____

(Please obtain prior to return of item)

Company: _____

Address: _____

Date: _____

Country: _____

Phone Number: _____

P.O. Number: _____

Fax Number: _____

Item(s) Being Returned:

Model #: _____

Serial #: _____

Description: _____

Reasons of return of goods (please list any specific problems): _____

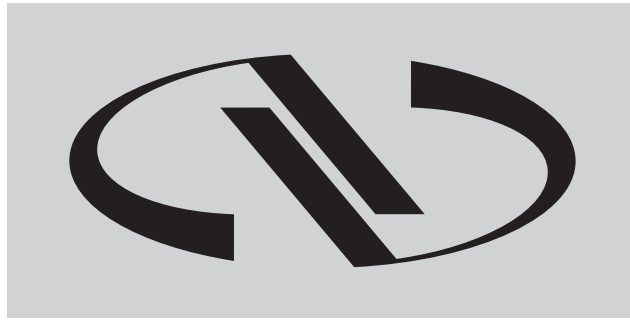

Newport®

Experience | Solutions

**Visit Newport Online at:
www.newport.com**

North America & Asia

Newport Corporation
1791 Deere Ave.
Irvine, CA 92606, USA

Sales

Tel.: (800) 222-6440
e-mail: sales@newport.com

Technical Support

Tel.: (800) 222-6440
e-mail: tech@newport.com

Service, RMAs & Returns

Tel.: (800) 222-6440
e-mail: service@newport.com

Europe

MICRO-CONTROLE Spectra-Physics S.A.S
9, rue du Bois Sauvage
91055 Évry CEDEX
France

Sales & Technical Support

Tel.: +33 (0)1.60.91.68.68
e-mail: france@newport.com

Service & Returns

Tel.: +33 (0)2.38.40.51.55