

# User's Manual of Spring Extension and Compression Testing Machine

## I. Overview

As a special-purpose instrument, this testing machine is used to test amount of deformation and characteristic of load relation of extension and compression springs. It can be applied to the testing of working load of extension and compression springs under certain working length. Advanced and highly integrated chip microprocessor is adopted by this machine, which also has liquid crystal display (English) and metal enclosure. The interference-killing feature of the system is thus greatly improved.

## II. Functional Features

1. Liquid crystal display (English); better Human Machine Interface (HMI)
2. High precision and resolution
3. Three kinds of measurement units can be selected(N, Lb and Kg); inter-conversion is available
4. The user can independently set up acceleration of gravity of the place of usage. In this way, the testing and unit conversion would be more accurate
5. 99 sets of test data can be stored; the user can directly look over, store and delete data in the machine
6. The user can freely shift among the following three patterns: Real-time and peak-value patterns and the pattern of automatic peak value
7. It has the function of client setup and free setup of upper and lower limits (corresponding to audible and visual alarms), storage value, holding value, automatic storage time of peak value, automatic shutdown time (non-operation), etc
8. Judgment of acceptance or rejection of test data to be printed and stored, maximum value, minimum value and mean value (only for tape printing machine)
9. MODBUS-RTU standard agreement is adopted for communication; USB interface is adopted for better connection with configuration and PLC connection

## III. Specification and Parameter

Model Number	ATH-10	ATH-20	ATH-30	ATH-50	ATH-100	ATH-150	ATH-200	ATH-300	ATH-500	ATH-1000	ATH-2000	ATH-3000	ATH-5000
Maximum testing load	10N	20N	30N	50N	100N	150N	200N	300N	500N	1000N	2000N	3000N	5000N
Minimum resolution	0.001N				0.01N				0.1N				
Diameter of the platen	34mm			49mm					108mm				
Maximum free length of measurable spring	80mm			150mm					200mm				
Length of travel of the displacement scale	60mm			90mm					150mm				
Division value of the displacement scale	0.01mm												
Indication error	±1%												
Power Supply	AC 110-220V, 50HZ-60HZ												
Power capability (without printer)	13W												
Power capability (with printer)	20W												
Working temperature	20±10°C												
Temperature of storage and transportation	-27°C~+70°C												
Relative temperature	15%~80%RH												

# IV. Product Structure

## 1. Schematic Diagram

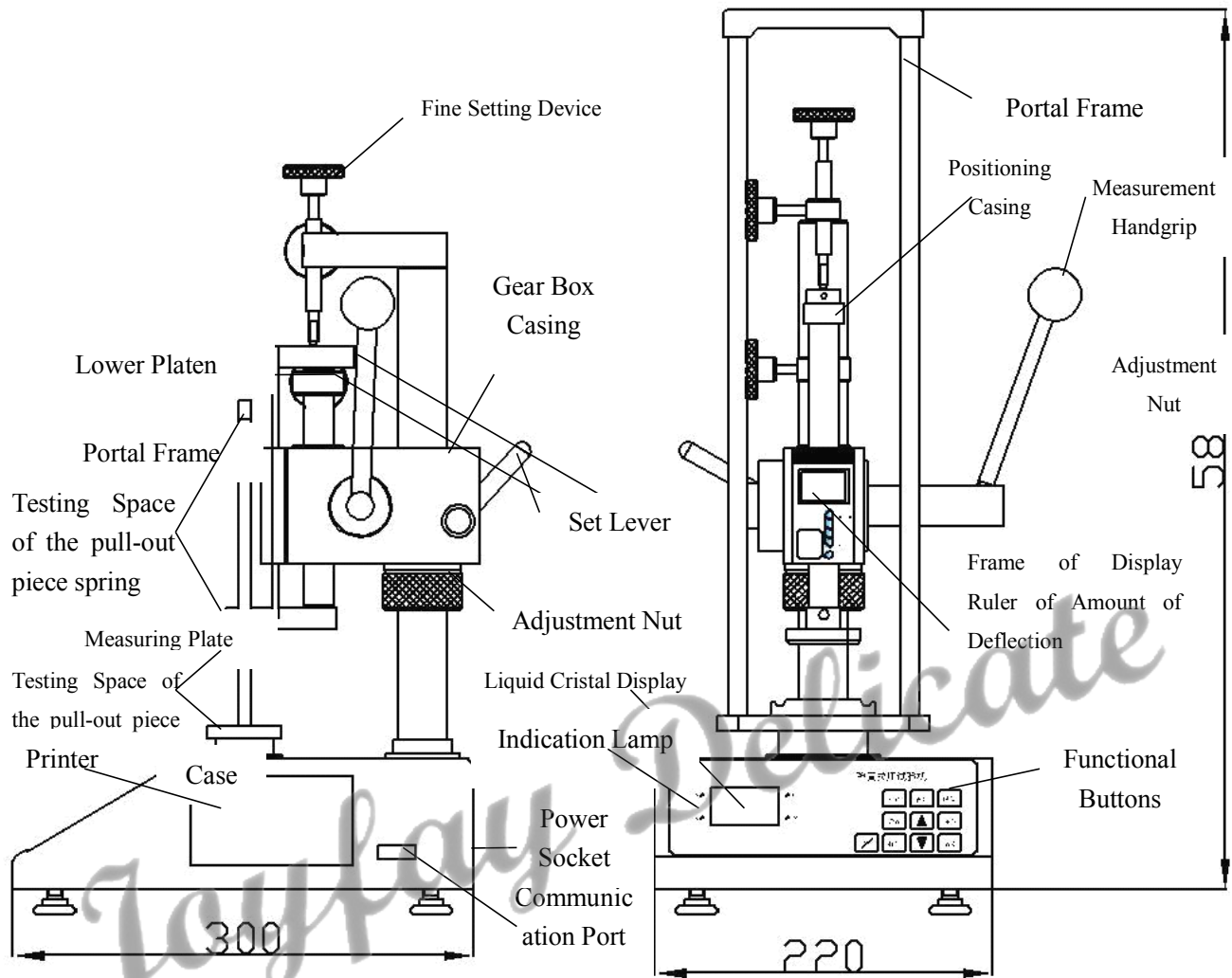

## 2. Frame of Display Ruler of Deflection

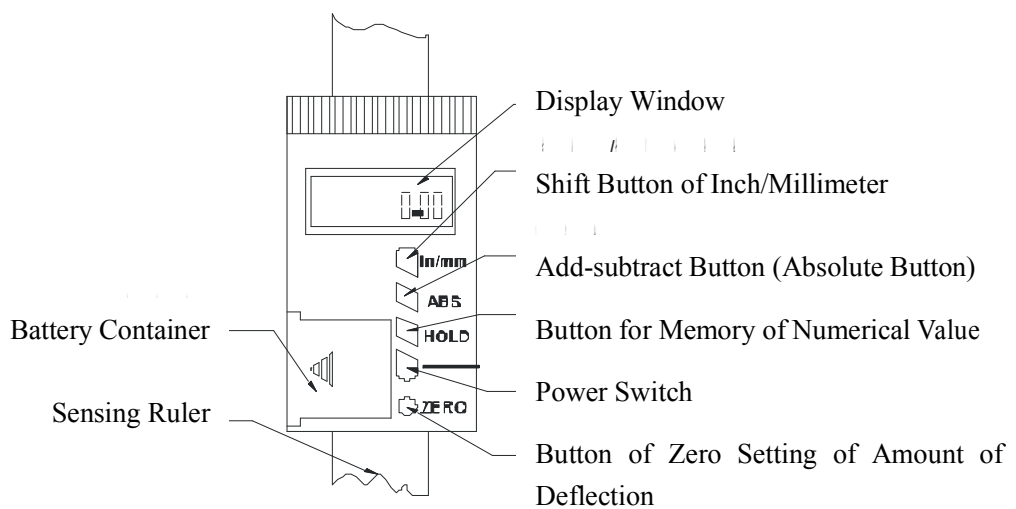

## V. Name and Function of Each Component on the Display Panel

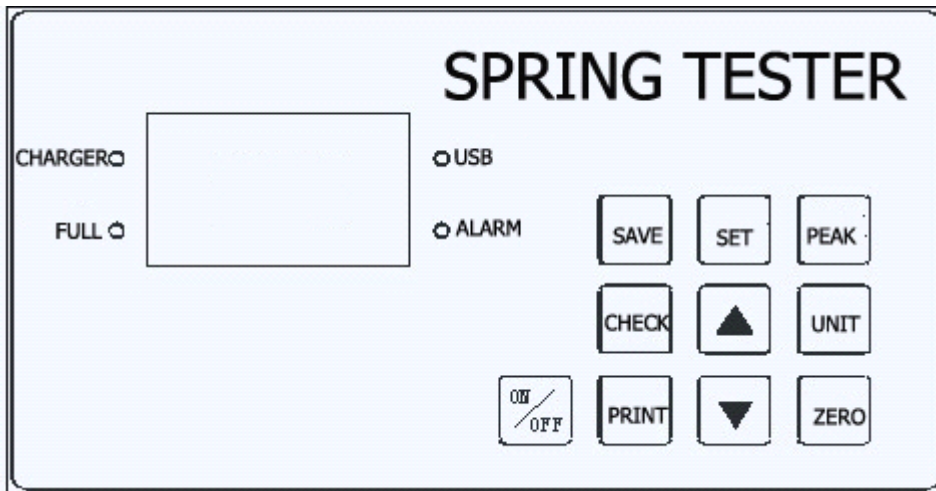

### 1. Liquid Crystal Display Window

#### a. Power-on Indication

Power-on indication: Name of the manufacturer: Welcome to use our products; product model number



#### b. Display of the Main User Interface

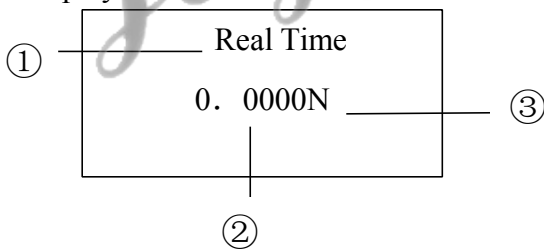

① Measurement patterns: There are three patterns: Real-time and peak-value patterns and pattern of automatic peak-value. The user might, according to his/her needs, freely select among them.

② Measurement force value

③ Measurement unit: There are three units: N, kg and lb. The user might, according to his/her needs, freely select among them.

### 2. Indication Lamp

① Upper limit: When the assorted power adapter is used to charge electricity, the red lamp would be lightened.

② Lower limit: When the assorted power adapter is used to charge electricity and the electricity is full, the green lamp would be lightened.

③ Printing: When instruments with printing function are used and the user press the button of "Print", the

green lamp would be lightened.

④ Communication: Alarm of upper and lower limits: When the measurement force value is higher than the upper limit value, the lamp would be lightened (red) and the buzzer would give out alarm; when the measurement force value is lower than the lower limit value, the lamp would be lightened (green) and the buzzer would give out alarm.

### 3. Functional Buttons

- a. “ON/OFF”: Power switch for on and off of the machine.
- b. “Print”: It is used in instruments with printers. If you press this button in the View Interface, the measurement data stored within the instrument would be printed out (excluding instruments without printing function).
- c. “Setup”: Under the measurement pattern, the user can enter into the setup menu through this button.
- d. “Save”: It is used to save measurement data.
- e. “View”: Under the measurement pattern, the user can look over the stored measurement data through this button. If the user presses this button again, it would return to the measurement pattern.
- f. “▲”: If the user presses this button on the User Setup Interface, he/she would be able to modify the setup items (upwardly or downwardly); if the user presses this button while setting up parameters, he/she would be able to modify the data in current position; if the user presses this button in the View Interface, he/she would be able to look over the last data.
- g. “▼”: If the user presses this button on the User Setup Interface, he/she would be able to modify the setup items; if the user presses this button while setting up parameters, he/she would be able to select the digit to be modified (digit by digit); if the user press this button on the View Interface, he/she would be able to look over the next data.
- h. “Peak-value Pattern”: It is used to shift among the following three patterns: Real-time and peak-value patterns and the pattern of automatic peak value.
- i. “Unit”: It is used to shift among the three units of N, kg and lb.
- j. “Zero Setting”
  - ① During real-time measurement, the user can press this button to modify the zero point;
  - ② Under the peak-value pattern and pattern of automatic peak value, the user can press this button to clear up the peak value and restore to the zero point;
  - ③ The user can press this button on the View Interface to clear up measurement values which are currently stored; he/she might also long-press this button to clear up all the stored measurement values;
  - ④ The user can press this button on the User Setup Interface to return to the previous interface without saving the data.

## VI. Working Environment

1. Operating temperature:  $-10^{\circ}\text{C} \sim 40^{\circ}\text{C}$ .
2. Operating humidity:  $\leq 90\% \text{RH}$ .
3. The environment shall be without vibration source surrounding it and without corrosiveness.

## VII. User's Operation Manual

1. Before using the digital torque tester, the user shall, first of all, inspect whether power line of the instrument is connected properly.
2. Under normal condition, if the user switches on the machine, the displayed force value would be zero. If the displayed force value is not zero, the user could press the button of “Zero Clearing” to clear the force value to zero.
3. Before testing, the user shall, first of all, set up the values of upper and lower limits, minimum storage value, minimum holding value of peak value, automatic peak-value time, automatic shutdown time and acceleration of gravity, etc. The specific operating procedures are as follows:
  - a. Press the button of “Setup” on the Main User Interface for the first time to enter into the User Setup Interface. The display would then be as follows:

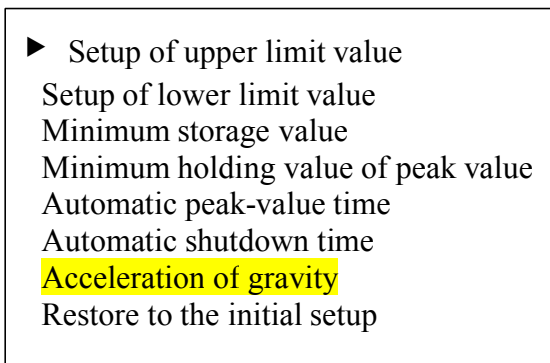

Through the buttons of “▲” or “▼”, the user can select setup items. When the user's setup item is selected, the user can press the button of “Setup” to enter into the Parameter Setup Interface.

### a. Parameter Setup Interface

On the User Setup Interface, the user can press the button of “Setup” to enter into the Parameter Setup Interface. The display is as follows:

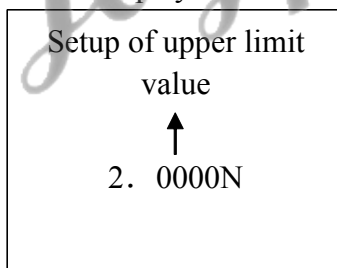

Illustration of setup parameters: (take the above-mentioned setup of values of upper and lower limits as examples)

Through the buttons of “▲” and “▼”, the user can modify and remove the data. At this time, if the user press the button of “Save”, he/she would be able to save the setup data. Interface of the displayer would then return to the User Setup Interface and the user would be able to set up the following setup item. (For example, if the user presses the button of “Zero Setting”, the machine would return to the User Setup Interface and no modification data would be stored). When all the setup items have been set up and saved, the user could directly press the button of “ON/OFF” to shut down the machine. Then he/she could press the button of “ON/OFF” to restart the machine and enter into the Main User Interface. The data setup shall not exceed the maximum loading value.

- ① **Setup of upper limit value:** The user can, according to his/her needs, freely set up the upper limit

value. When the upper limit value is reached, automatic audio & lighting alarms would be given out. The upper limit value shall not be higher than the full range.

② **Setup of lower limit value:** The user can, according to his/her needs, freely set up the lower limit value. When the lower limit value is reached, automatic audio & lighting alarms would be given out. The setup of lower limit value shall not be higher than the setup of upper limit value.

③ **Setup of minimum storage value:** The user can, according to his/her needs of storage, set up the minimum storage value. Data the values of which are smaller than the minimum storage will not be stored.

④ **Setup of the minimum holding value of peak value:** The user can, according to his needs of measurement of the peak value and automatic peak value, freely set up the minimum holding value of peak value. Data the values of which are smaller than it will not be stored.

⑤ **Setup of the automatic peak-value time:** The user can, according to the time of peak value which needs to be kept under the measurement status of automatic peak value, freely set up the automatic peak-value time (1-99 seconds).

⑥ **Setup of the automatic shutdown time:** Under the status of non-operation, the automatic shutdown time can be freely set up (0-9 minutes) (when the setup value is 0, it means that automatic shutdown is disabled).

⑦ **Setup of acceleration of gravity:** The user can, according to position of local area, set up value of the acceleration of gravity. Default value of this machine is 9.794.

⑧ **Restore to the initial setup:** When confusion is caused due to improper operation of the user or the fact that the user modifies the data for many times, the user could, through this setup, restore the data (1-7) to the factory default.

4. Before testing, the user shall, secondly, select the measurement pattern

When the Main User Interface is shown as the real-time measurement pattern, the user can: Enter into the peak-value measurement pattern by pressing the button of “Peak-value Pattern” for the first time; enter into the measurement pattern of automatic peak value by pressing the button of “Peak-value Pattern” for the second time; enter into the real-time measurement pattern by pressing the button of “Peak-value Pattern” for the third time. The cycling sequence is as follows:

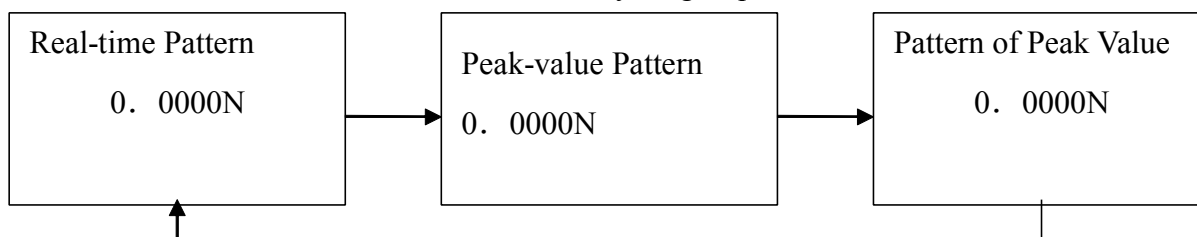

5. Before testing, the user shall, thirdly, select the measurement units

Under any measurement pattern, the user can: Enter into the display of the unit of Kg from the unit of N by pressing the button of “Unit” for the first time; enter into the display of the unit of lb by pressing the button of “Unit” for the second time.

6. During the testing process, the user shall, first of all, unscrew the set lever. Then he/she shall, as required, rotate the adjusting nut and remove the gear case body. Finally, he/she shall screw up the set lever.

A. While testing amount of deformation and working load of the extension spring, the user shall drive the

handgrip upwardly, connect the hook head of the pullback spring and drive (adjust) the measurement handgrip. When the display of working load is approaching the value of testing load of the tested spring, he/she shall push down the button of “ZERO” on the frame of display ruler of the amount of deformation, append the tested pullback spring, drive and pull the handgrip to the required amount of deformation (namely, the working length of the pullback spring displayed on display window of the amount of deformation) and read the displayed numerical value of load, which is the working load of the spring under the amount of deformation.

B. While testing amount of deformation and working load of the compression spring, the user shall drive the handgrip downwardly to cause the upper and lower platens (measurement contactors) to touch with each other and drive (adjust) the measurement handgrip. When the display of working load is approaching the value of testing load of the tested spring, he/she shall push down the button of “ZERO” on the frame of display ruler of the amount of deformation, place the tested pull-out piece spring, rotate and press the handgrip to the required amount of deformation (namely, the working length of the pullback spring displayed on display window of the amount of deformation) and read the displayed numerical value of load, which is the working load of the spring under the amount of deformation.

During the testing process, the user can press the button of “Save” to save the measurement data.

**Note: During the testing process, when the measurement value exceeds the upper limit value, the communication indication lamp would become red and the buzzer would give out alarm; when the measurement value is less than the lower limit value, the communication indication lamp would become green and the buzzer would give out alarm. When the measurement value exceeds 120% of the peak load, the transducer would probably be damaged; when the measurement value exceeds 150% of the peak load, the system would surely be damaged. When the warning reminder of “Serious Overload” appears, the machine would automatically be shut down and enter into the status of automatic protection. At this time, the machine shall be start up again. When the warning reminder of “Serious Overload” is displayed on the displayer, the user can enter into the User Setup Interface by pressing the button of “Setup”. By utilizing the button of “▼”, he/she can select to restore the initial setup item. After that, he/she shall press the button of “Setup” and the displayer would then display the reminder for input of the password. The input of password is as follows: “▲”, “▼”, “Peak-value Pattern”, “Save”, “▲”, “▼”, “Peak-value Pattern” and “Save” (in sequence). After input of the password, the system can be restored (if this fails, please contact with the manufacturer).**

7. User’s Manual of the staff gauge with digital display

① in/mm: This button is for conversion of units. It is used for shift between inch and millimeter;

② ABS: This button is the absolute button;

- If the display window displays a certain numerical value (without the character of “ABS”), it would mean the normal measurement pattern;
- After pressing this button, the display window will display the numerical value of zero (with the character of “ABS”).It means the ABS measurement pattern and here would be the starting point for measurement of the distance. The displayed numerical value is the one under the ABS measurement pattern;
- After pressing this button again, if the numerical value is without the character of “ABS”, it would mean that the system is returned to the normal measurement pattern. The displayed numerical value

is the one under the normal measurement pattern.

③ hold: This button is for memory lockout. If the user presses this button, the numerical value would be locked out. If no change happens and the user presses this button again, the lockout function would be cleared away. If no change happens and the user presses this button again, the lockout function would be cleared away;

④ ON/OFF: This button can be used to switch on or off the machine;

⑤ ZERO: This button is for zero setting. It can be used to carry out zero clearing of the displayed numerical value.

8. After the testing, the user can press the button of “View” to look over the stored data. Through the buttons of “▲” and “▼”, the user can display the last piece of stored data or the next piece of stored data.

9. After using the spring testing machine, the user shall press the button of “ON/OFF” to switch it off for later use. If the machine is not used for a long time, the user shall unplug the power plug and cover the spring testing machine with a duster.

## VIII. USB Output

This instrument communicates with the upper computer through USB and the MODBUS-RTU communication protocol is adopted by it. Specific connecting method of the instrument and software is as follows:

1. Use the straight-through cable to connect this instrument and the computer as well as male connector of the USB and this instrument. Female connector of RS-232 shall be connected to the computer.
2. Switch on power supply of the instrument and let it be on the measurement interface.
3. Put the disk attached to the machine into the optical drive of the computer and open path of the software of serial port: Optical Drive\aliyiqi\AutoTest.exe.
4. Click the button of “System” in lower part of the window of the software and the dialog box of “System Setting” would pop up. The user can then select corresponding serial ports of the computer among the communication ports. Specific procedures of operation are as follows:
  - ① Right-click “My Computer” and select “Property”. The dialog box of “System Property” will pop up and the user shall select the optional field of “Hardware” from it and click the button of “Device Manager”:
  - ② After the dialog box of “Device Manager” is pop up, the user can view the serial port number (sub-item) of the port options:
  - ③ Return to the dialog box of “System Setup” which has popped up, select corresponding serial port number among the communication ports (for instance, 5) and press the button of “Confirm”:
  - ④ Shut down the software and double-click the button of AutoTest.exe again. At this time, the user can inspect whether the serial ports have been connected. There are many kinds of inspection methods: Exert some force to transducer of the instrument and check whether the torque value on upper side of the software window is pulsing accordingly. If it is pulsing, it would mean that the connection is completed; otherwise it would mean that the connection is not completed.
  - ⑤ Click the button of “Setup” on lower part of the software window and the dialog box of “Parameter Setup” will pop up. The user shall, according to needs of the testing, fill in relevant data. For details of values of parameters, please refer to the description of the step of 6-3-b. After completion of the data input, please press the button of “Confirm”. If the setup is successful, the data displayed on lower part of



the software window will be changed accordingly.

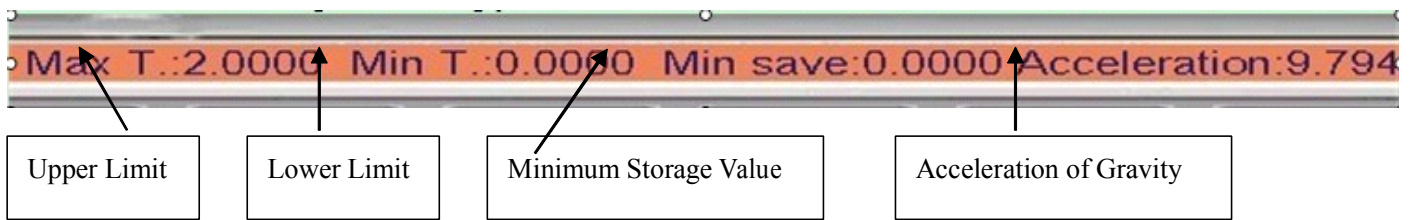

- ⑥ First of all, make sure that the serial ports have been connected. Then press the button of “Begin” to carry out the synchronization test.
- ⑦ After completion of the test, the user shall click the button of “Save” or “Shut Down”. If the button of “Save” is pressed, the test curve would be saved into the software; if the button of “Shut Down” is pressed, the test curve would not be saved into the software.
- ⑧ Introduction of the software interface:
  - A. On the upper side, there are Display Area of Torque Value, Display Area of Time and Number of Testing Times.
  - B. On the left side, there are Upper Limit Line, Lower Limit Line, Indication Line, Specification Display, Display Curve, Erase Curve and Derive Curve.

Specification Display: Just as its name implies, it means specification(model number and measurement range) display of the instrument.

Upper Limit Line: When the box in front of the upper limit line is checked, there is display of horizontal line of the torque value of upper limit on the display window of curve.

Lower Limit Line: When the box in front of the lower limit line is checked, there is display of horizontal line of the torque value of lower limit on the display window of curve.

Indication Line: Within the display window of curve, the mouse would be shown as a cross. When position of the mouse (cross) moves, the display areas of torque value and time would be changed accordingly.

Display Curve: By pressing this button, the user can jump out of the dialog box of “Curve Selection”, select test items which need to be displayed and then select the times of testing which needs to be displayed.

Erase Curve: If the user presses this button, the currently displayed curve would be erased. However, it does not mean that the currently displayed curve would be deleted from the software.

Derive Curve: If the user presses this button, the dialog box of “Derive Curve” would pop up. The user shall, after selecting the format of figures of curves which are needed and the saving path, press the button of “Confirm”.

C. On the lower side, there are buttons of Setup, Begin, Shut Down, Report Form, System, Help, Delete and Exit.

The buttons of Setup, Begin, Shut Down and System have been introduced previously.

Report Form: If the user presses this button, the dialog box of “Preview of Curve Data Selection” would pop up. The user shall, first of all, select size of frequency of the sampling point. Then he/she shall select the test items which need to be displayed or times of test which need to be displayed. Finally, he/she shall press the button of “Excel”.

## IX. Matters Needing Attention

Operational mistakes may damage this instrument or result in serious accident. This *User's Manual* points out material particulars for accident prevention and directions of the instrument. Before using the instrument, please carefully read this User's Manual. After reading it, please keep it properly for future use.

### • Matters Needing Attention for Use of It

A. The environment shall be kept tidy, so as to avoid intrusion of substances such as liquid and scrap iron, etc to the components of the transducers of amount of deformation and working load. Such intrusion may cause damage to electronic components.

B. Please use soft cloth to clean this instrument. Add some detergent to the water and immerse the cloth into the water. After that, wring it out and clean up the dusts and dirt.

**Note: Do not use highly volatile chemical substances (such as propellant, thinner and alcohol, etc) to clean this instrument.**

C. Please do not operate this machine under the following environments:

- (1) Damp environment.
- (2) Dusty environment.
- (3) Place where oil or chemicals are used.
- (4) Place where there are vibration source around it.

D. The surfaces of the sensing caliper of amount of deformation and slippery rack can be scrubbed by white gasoline. In addition, they can be lubricated by small amount of watch oil. It is not allowed to use acetone or alcohol.

E. If the instrument is not used for a long time, please unplug the power plug and get done with the dust-proof and moisture-proof works.

## X. Malfunctions and Maintenance

Phenomenon	Cause	Maintenance
The displayer of amount of deformation only displays 000.00 or IN00.000	Short circuit of spring leaf of the dual-function button	Take down the protective frame and make sure that spring leaf of the button is in a perfect state
Functional buttons of the displayer of amount of deformation fail to function	The spring leaf is deformed due to the reason that the user press the functional button too hard	Take down the protective frame and make sure that spring leaf of the button is in a perfect state
After using for a period of time, out-of-tolerance of the span indicating value of the amount of deformation $\leq 0.1\text{mm}$	Filth has permeated through the transducer of amount of deformation	Take down the protective frame, dismantle fittings of the displayer and use cleaning pressured air ( $\leq 5\text{kg/cm}$ ) to blast surface of the transducer. In addition, use small amount of gasoline wipe it and clear away filth on it.
The load displayer displays nothing	1. The power supply is not connected properly. 2. The machine is not switched on	1. Connect the power supply properly. 2. Press the button of "Switch" again.

## XI. Packing List

Number	Name	Quantity
1	Main body of the Spring Tension and Compression Testing Machine	1 set
2	Portal frame	1 suit
3	Fine setting device	1 suit
4	Assembly of draw hook	1 suit
5	Extension rod (draw hook)	1 suit
6	Button-cell batteries for display of amount of deformation	1 piece
7	Power line	1 piece
8	Straight-through cable	1 piece
9	Assorted software disk	1 piece
10	User's Manual	1 piece
11	Certificate of Product Inspection	1 piece
12	Warranty Card and Certificate of Compliance of the Product	1 piece

Joyfay Delicate