



12 VOLT

LOW VOLTAGE DISCONNECT USER MANUAL



P/No LVD30 & LVD50

WARNING

- PLEASE READ THESE INSTRUCTIONS COMPLETELY PRIOR TO INSTALLATION.
- BATTERIES PRODUCE EXPLOSIVE GASES – Ensure no sparks or flames are present.
- Wear eye protection.
- Vehicles must be in 'NEUTRAL' or 'PARK', park brakes 'ON'.
- Follow all vehicle manufacturer's instructions.
- Beware of moving parts.
- Low Voltage Disconnects (LVD) are designed for negative ground alternator systems with batteries of the same nominal voltage.
- Batteries of differing voltages cannot be used.

FEATURES

OVER DISCHARGE PROTECTION

Protects batteries and equipment from damage due to over discharge

ADJUSTABLE DISCONNECT POINT

Set the disconnect point to best suit the Application

FULLY SEALED (IP65)

Fully sealed shock proof aluminium housing protects against water and dust ingress

PRODUCT OVERVIEW



REAR VIEW

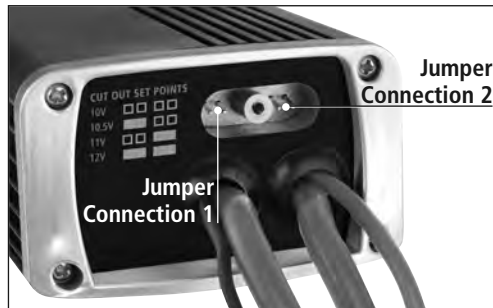

Adjustable Disconnect Points
Set the voltage disconnect point at 10, 10.5, 11 or 12V

INSTALLATION

1. Low voltage disconnect units feature a fully sealed (IP65) shock proof aluminium housing, protecting the unit against water and dust ingress. The LVD end plates include a mounting flange for easy mounting, if permanently fixed the LVD should be mounted to a suitable horizontal or vertical panel. Mount in a convenient location. Mount as far away as possible from the exhaust manifold, turbo or any other high temperature components. Do not mount on the engine.
2. Disconnect the negative battery cable (Ground) from the starting battery.
Note: To prevent the loss of the vehicle's electronic memory, preset radio and security codes it is recommended that an 'Electrical System Memory Protector' (P/No. IPS700) be used.
3. Connect the LVD 'INPUT' (+) wire to the battery.
Note: For safety reasons it is recommended to install a fuse close to the battery.
4. Connect the LVD 'OUTPUT' (+) wire to the auxiliary load.
5. Connect the LVD 'GROUND' (-) wire (small black wire) to a suitable chassis bolt or screw ensuring a good electrical connection is made.
6. Reconnect the main/starting battery's negative cable (Earth).
7. The 'REMOTE' wire must be connected to a positive 12V power source for the LVD to operate.
 - a) Connect 'REMOTE' wire to the vehicle's ignition or accessories switch. The LVD will operate only when the ignition or accessories switch is turned on. Install a fuse to the remote wire as close as possible to the ignition switch.

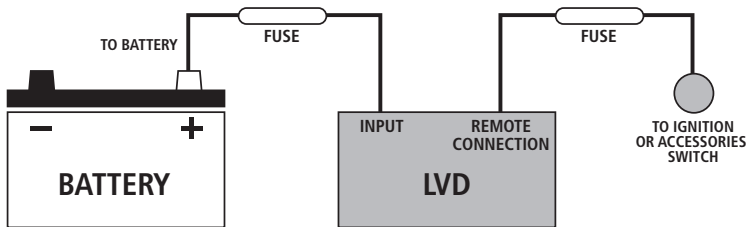

Note: Fuses used when wiring the LVD unit should be rated to the cable being used for the installation.

- b) For continuous operation connect the 'REMOTE' wire to the LVD positive 'INPUT' wire.

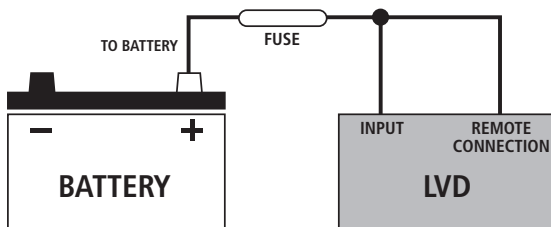

Note: Fuses used when wiring the LVD unit should be rated to the cable being used for the installation.

WIRING DIAGRAM

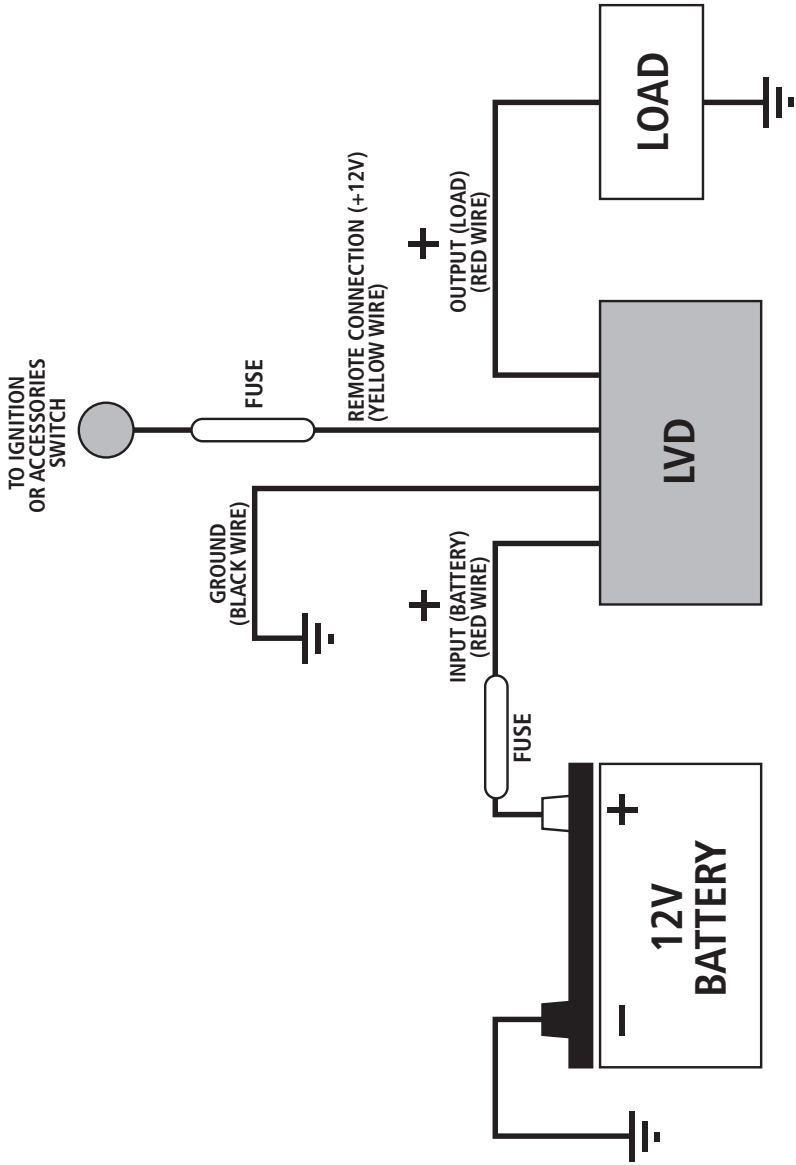





Note: Fuses used when wiring the LVD unit should be rated to the cable being used for the installation.

OPERATING INSTRUCTIONS

The LVD unit monitors the battery voltage and disconnects the DC load when the battery voltage falls below the set disconnect point, preventing further discharge and possible damage. Once the set disconnect point has been reached, a 60 second delay will occur prior to disconnection allowing for short periods of low voltage eg engine starting. Once the battery is recharged and the battery voltage is above 13V the DC load will automatically be reconnected. The LVD can also be reconnected manually prior to reaching 13V by pressing the reset button.

SETTING VOLTAGE DISCONNECT POINTS

The LVD allows you to set the voltage disconnect point of your unit to best suit your application. Disconnect points are set by applying the jumper pins provided to the jumper connection points at the back of the unit. The table below illustrates the 4 disconnect points that can be set by applying the jumper pins in the following sequences:

DISCONNECT POINT	JUMPER CONNECTION		ILLUSTRATION
	LEFT	RIGHT	
10V	N/A	N/A	
10.5V (default)	Pin installed	N/A	
11V	N/A	Pin installed	
12V	Pin installed	Pin installed	

OVERLOAD

In the event your LVD unit exceeds its maximum operating temperature the LVD will disengage and the LED on the front of the unit will flash red. Once the LVD has reached a safe operating temperature the LED will illuminate solid red indicating the load is disconnected. When the battery reaches above 13.0V, the LED on the front of the unit will then flash green (Check Load) indicating that the LVD has reconnected. You can reset the device at any stage by pressing the reset button on the front of the unit.

An overload situation will occur due to excessive current draw being placed on the LVD unit, if the Check Load LED illuminates it is advised to check the load which has been connected to the LVD unit to ensure it is best suited to the model of LVD chosen for your application.

FUSE FAILURE

If your LVD unit displays a green & red flashing LED this will be indicating a fuse failure. To replace the fuses remove the screws from the bottom of the unit and remove cover. Remove and refit with 30A blade fuses. Refit the bottom cover of your LVD unit.

LVD ACTIVITY/STATUS

LED SIGNAL		STATUS	REMEDY
Green	○	Monitoring	No action required
Red	●	Load Disconnect	Recharge your battery or press the reset button to reconnect the LVD manually prior to reaching the automatic reconnect point (13V)
Red (Flashing)	☀	Overload	Check the load connected to the LVD, overload situation has occurred due to excessive current draw
Green (Flashing)	☀	Check Load	
Red / Green (Flashing)	☀ / ☀	Fuse Failure	Replace fuse, check wiring for short circuit
OFF		No Power to LVD	No action required

SPECIFICATIONS

P/No:	LVD30	LVD50
Output Current	30A	50A
Input Voltage	10–16V	10–16V
Current Draw	10mA	10mA
LVD Disconnect (Disconnect delay 60 seconds)	10V, 10.5V, 11V & 12V	10V, 10.5V, 11V & 12V
LVD Reconnect	13V	13V
Size (mm)	108 x 66 x 38	180 x 66 x 38
Weight	0.3kg	0.5kg
Fuse	1 x 30A Blade Fuse	2 x 30A Blade Fuse

WARRANTY STATEMENT

Brown & Watson International Pty Ltd ("BWI") of 1500 Ferntree Gully Road, Knoxfield, Vic., telephone (03) 9730 6000, fax (03) 9730 6050, warrants that all products described in its current catalogue will under normal use and service be free of failures in material and workmanship for a period of one (1) year from the date of the original purchase by the customer as marked on the invoice. This warranty does not cover ordinary wear and tear, abuse, alteration of products or damage caused by the purchaser.

To make a warranty claim the consumer must deliver the product at their cost to the original place of purchase or to any other place which may be nominated by either BWI or the retailer from where the product was bought in order that the warranty assessment may be performed. The consumer must also deliver the original invoice evidencing the date and place of purchase together with an explanation in writing as to the nature of the claim.

In the event that the claim is determined to be for a minor failure of the product then BWI reserves the right to repair or replace it at its discretion. In the event that a major failure is determined the consumer will be entitled to a replacement or a refund as well as compensation for any other reasonably foreseeable loss or damage.

This warranty is in addition to any other rights or remedies that the consumer may have under State or Federal legislation.

IMPORTANT NOTE

Our goods come with guarantees that cannot be excluded under the Australian Consumer Law. You are entitled to a replacement or refund for a major failure and compensation for any other reasonably foreseeable loss or damage. You are also entitled to have the goods repaired or replaced if the goods fail to be of acceptable quality and the failure does not amount to a major failure.

Distributed by

AUSTRALIA

Brown & Watson International Pty Ltd

Knoxfield, Victoria 3180

Telephone (03) 9730 6000

Facsimile (03) 9730 6050

National Toll Free 1800 113 443

NEW ZEALAND

Narva New Zealand Ltd

22–24 Olive Road

PO Box 12556 Penrose

Auckland, New Zealand

Telephone (09) 525 4575

Facsimile (09) 579 1192