

AUTOCLAVEERBARE BIOREACTOR

2 - 7 LITER

GEBRUIKSAANWIJZING

INHOUDSOPGAVE

Hoofdstuk	Omschrijving	Pagina
1	Hardware specificatie	1-1
1.1	Algemeen	1-1
1.2	De reactoren	1-2
1.3	De deksels	1-7
1.4	De roerder	1-9
2	Roeren en beluchten	2-1
3	Gebruik	3-1
3.1	Algemeen	3-1
3.2	Klaarmaken voor sterilisatie	3-1
3.3	Sterilisatie	3-2
3.4	Installatie	3-2
3.5	Klaarmaken voor gebruik	3-2
3.6	Enting	3-3
3.7	Acties tijdens fermentatie	3-3
3.8	Pasteurisatie	3-3
4	Onderhoud	4-1
4.1	De reactor	4-1
4.2	De roerder	4-2
4.3	Hulpstukken en reserveonderdelen	4-3

HOOFDSTUK 1

HARDWARE SPECIFICATIE

1.1 ALGEMEEN:

De geroerde-tank reactor is het in de praktijk van de biotechnologie meest toegepaste type bioreactor.

De 2 - 7 liter autoclaveerbare bioreactoren van Applikon brengen verschillende voordelen met zich mee; door modulair en flexibel ontwerp wordt de beschikbare ruimte optimaal benut en is de reactor zeer praktisch in het gebruik.

In combinatie met de roersystemen, motoren, roervinnen en andere hulpstukken van Applikon kan elke gevraagde configuratie snel worden opgebouwd, bijvoorbeeld voor toepassingen als:

- medium optimalisatie,
- controle van cellijnen,
- produkt optimalisatie,
- studies ten aanzien van schaalvergroting/-verkleining,
- reactor optimalisatie,
- continue culturen,
- perfusie systemen, etc.



Gevaar:

Glas is een materiaal dat snel beschadigd kan worden (krasjes op het oppervlak). Daardoor vermindert de materiaalsterkte. De procesdruk dient om deze reden beneden de 50 kPa (0.5 bar, 7 psig) gehouden te worden. Reduceer de inlaatdruk van de gassen tot dit niveau of gebruik een juist ingestelde drukveiligheid!

1.2 DE REACTOREN:

De 2 - 7 liter bioreactoren zijn ideale gereedschappen voor onderzoekers die zich bezig houden met fermentatiestudies en voor die toepassingen waar kleine of middelmatige reactorvolumes worden gebruikt.

Vanwege het modulair ontwerp kunnen de reactoren ingezet worden bij een scala van toepassingen met inbegrip van microbiologische- en gistfermentaties, dierlijke en plantaardige celkweek, etc.

Reactormateriaal:	borosilicaat glas.
Andere materialen in contact met het medium:	roestvast staal (deksel), silicone rubber, viton en EPDM.

De reactor-typen en bijbehorende specificaties staan hieronder weergegeven.

- De 2 l bioreactor met schaalvormige bodem Z611020002:

Specificaties:

Maximum werkvolume : 2.2l (H/D verhouding = 2.3)

Minimum werkvolume : 0.5l

Werkvolume : 1.7l (H/D verhouding = 1.9)

Een warmtewisselaar binnen de reactor of een siliconen verwarmingsmantel om de reactor heen kunnen worden gebruikt voor de temperatuurregeling. De reactor wordt geleverd met standaard.

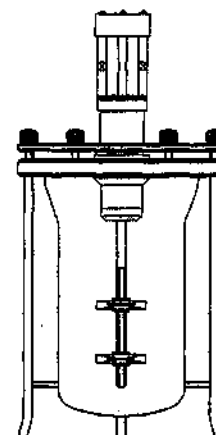

- De 2 l bioreactor met mantel Z61104CT04:

Specificaties:

Maximum werkvolume : 2.2l (H/D verh. = 2.3)

Minimum werkvolume : 0.5l

Werkvolume : 1.7l (H/D verh. = 1.9)

Mantelvolumen : 1.3l

Deze reactor is speciaal ontwikkeld voor de dierlijke celkweek; het grote verwarmingsoppervlak en de warmtecapaciteit van water verzekert een optimale temperatuurregeling.

De reactor wordt geleverd met standaard.

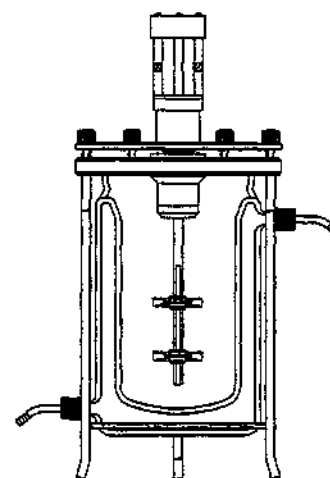

- De 3 l bioreactor met platte bodem Z611000004:
Deze reactor wordt vooral gebruikt voor bacteriële fermentaties met micro-organismen die niet gevoelig zijn voor afschuifkrachten.

Specificaties:

Maximum werkvolume	: 3.2l (H/D verhouding = 1.8)
Minimum werkvolume	: 0.44l
Werkvolume	: 2.6l (H/D verhouding = 1.5)

Een warmtewisselaar binnen de reactor of een siliconen verwarmingsmantel om de reactor heen kunnen worden gebruikt voor de temperatuurregeling.

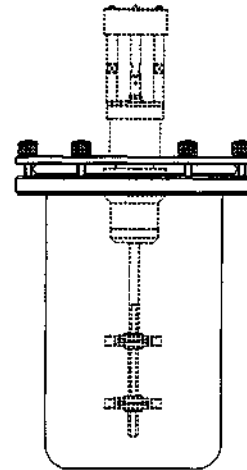

- De 3 l bioreactor met schaalvormige bodem Z61101C006:
Deze reactor wordt normaal gebruikt voor het kweken van voor afschuifkrachten gevoelige cellen/organismen. De schaalvormige bodem zorgt voor optimale roer-eigenschappen.

Specificaties:

Totaalvolume	: 3.2l (H/D verhouding = 1.9)
Minimum werkvolume	: 0.47 l
Werkvolume	: 2.7l (H/D verhouding = 1.5)

Een warmtewisselaar binnen de reactor of een siliconen verwarmingsmantel om de reactor heen kunnen worden gebruikt voor de temperatuurregeling.

De reactor wordt geleverd met standaard.

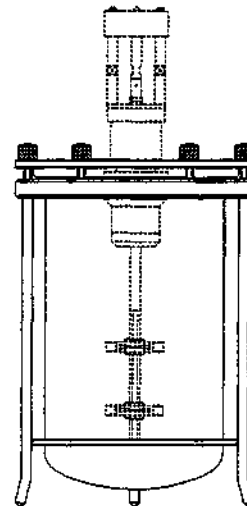

- De 3 l bioreactor met mantel Z61103CT04:
 Deze reactor heeft dezelfde specificaties als de 3 l reactor met schaalvormige bodem; echter, de temperatuurregeling wordt nu tot stand gebracht door middel van een watermantel, hetgeen een meer nauwkeurige regeling oplevert. De mantel kan worden gebruikt voor zowel verwarmen als koelen.

Mantel volume : 1.3l

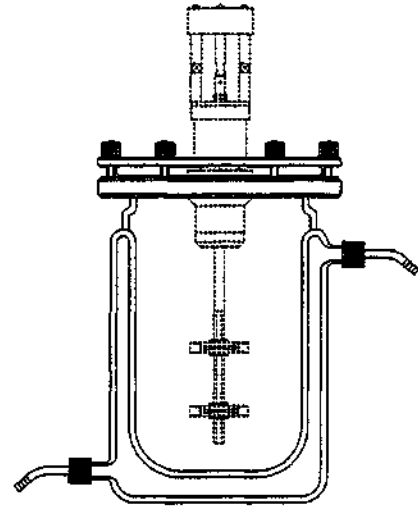

- De 5 l bioreactor met schaalvormige bodem Z611000005:
 Specificaties:
 Maximum werkvolume : 4.8l (H/D verh. = 1.6)
 Minimum eorkvolume : 2l
 Werkvolume : 3.4l (H/D verh. = 1.1)

Een warmtewisselaar binnen de reactor of een siliconen verwarmingsmantel om de reactor heen kunnen worden gebruikt voor de temperatuurregeling.
 De reactor wordt geleverd met standaard.

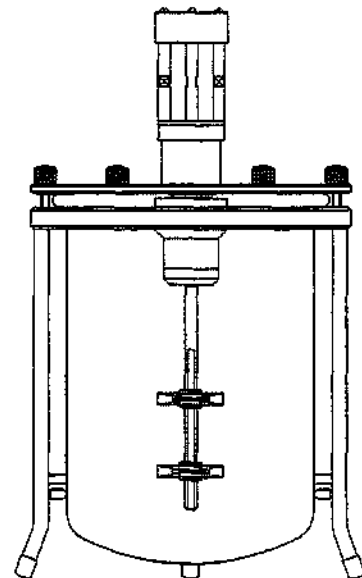

- De 5 l bioreactor met mantel Z61104CT05:

Deze reactor heeft dezelfde specificaties als de 5 l reactor met schaalvormige bodem; echter, de temperatuurregeling wordt nu tot stand gebracht door middel van een watermantel, hetgeen een meer nauwkeurige regeling oplevert. Hierdoor is deze geschikt voor dierlijke celkweek. De mantel kan worden gebruikt voor zowel verwarmen als koelen.

Mantelvolumen : 2.8l

De reactor wordt geleverd met standaard.

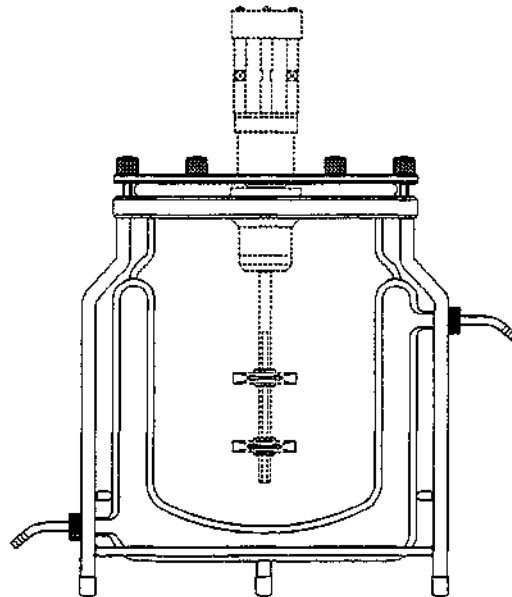

- De 7 l bioreactor met schaalvormige bodem Z611000007:

Specificaties:

Maximum werkvolume : 6.9l (H/D verh. = 2.2)

Minimum werkvolume : 2.0l

Werkvolume : 5.4l (H/D verh. = 1.8)

Een warmtewisselaar binnen de reactor of een siliconen verwarmingsmantel om de reactor heen kunnen worden gebruikt voor de temperatuurregeling.

De reactor wordt geleverd met standaard.

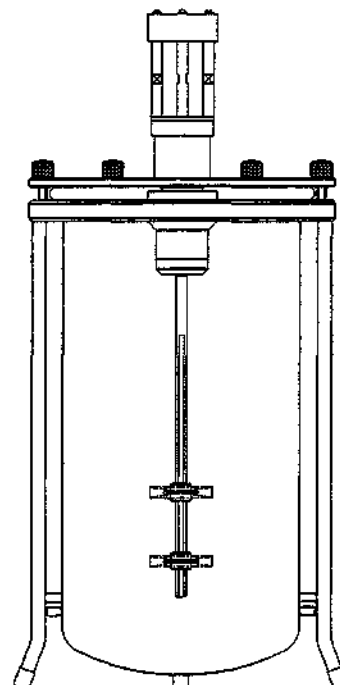

- De 7 l bioreactor met mantel Z61103CT07:

Deze reactor heeft dezelfde specificaties als de 7 l reactor met schaalvormige bodem; echter, de temperatuurregeling wordt nu tot stand gebracht door middel van een watermantel, hetgeen een meer nauwkeurige regeling oplevert. Hierdoor is deze geschikt voor dierlijke celkweek.

De mantel kan worden gebruikt voor zowel verwarmen als koelen.

Mantelvolumen : 4.2l

De reactor wordt geleverd met standaard.

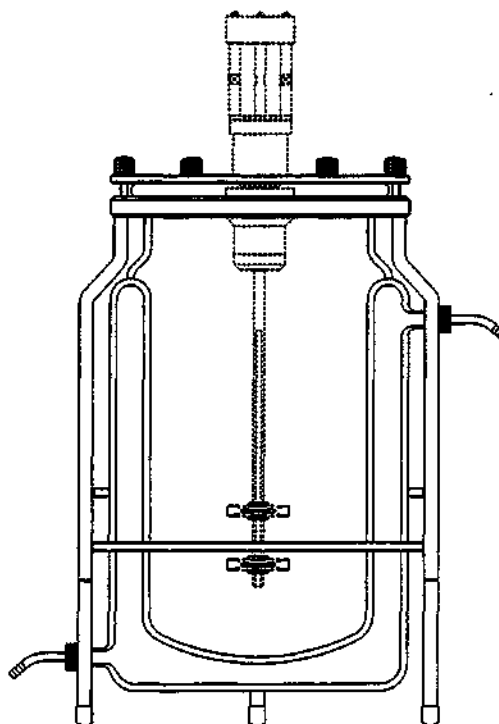

1.3 DE DEKSELS:

De reactordeksels zijn gemaakt van roestvast staal 316. De indeling van de gaten in de deksels is weergegeven in de onderstaande tekeningen.

De 2 liter reactor:

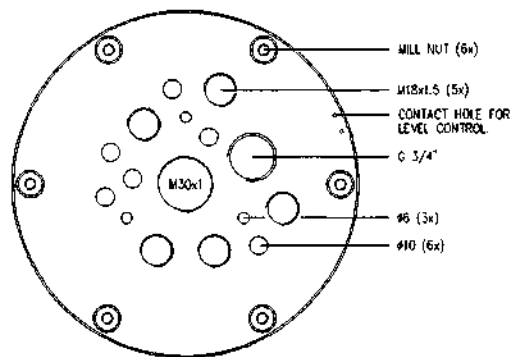

Dit deksel bevat de volgende poorten:

- een centrale M 30 x 1 poort (voor de bovenroerder),
- een G3/4" poort (voor de opgelost zuurstof sensor),
- vijf M 18 x 1.5 poorten (voor hulpstukken),
- drie 6 mm poorten (voor keerschotten of andere hulpstukken),
- zes 10 mm poorten (voor hulpstukken).

De 3 liter reactor:

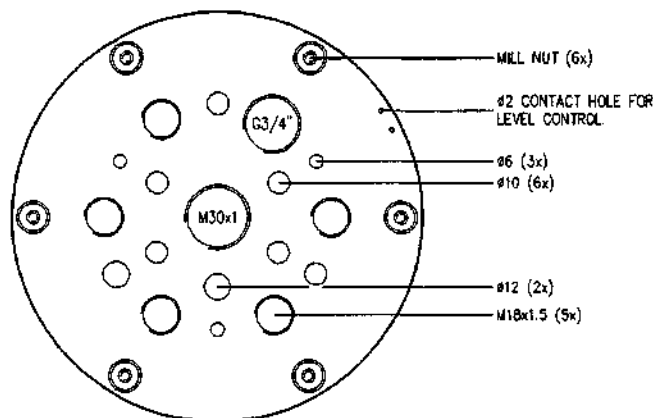

Dit deksel bevat de volgende poorten:

- een centrale M 30 x 1 poort (voor de bovenroerder),
- een G3/4" poort (voor de opgelost zuurstof sensor),
- vijf M 18 x 1.5 poorten (voor hulpstukken),
- drie 6 mm poorten (voor keerschotten of andere hulpstukken),
- zes 10 mm poorten (voor hulpstukken).
- twee 12 mm poorten (voor hulpstukken zoals een oogstpijp, etc.),

De 5 en 7 liter reactor:

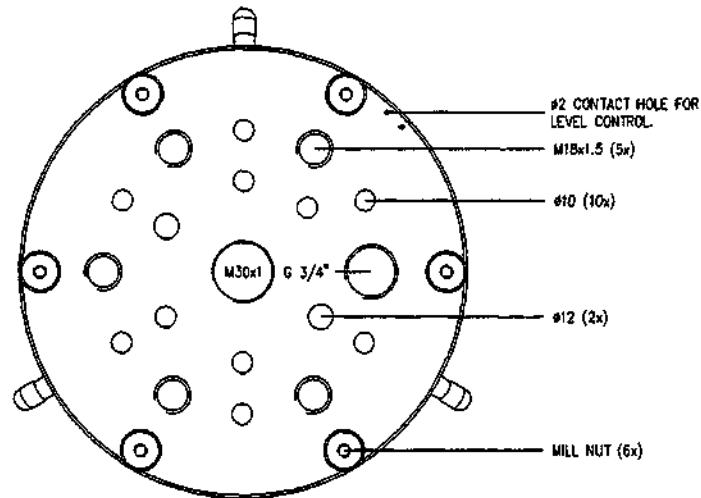

Dit deksel bevat de volgende poorten:

- een centrale M 30 x 1 poort (voor de bovenroerder),
- een G3/4" poort (voor de opgelost zuurstof sensor),
- vijf M 18 x 1.5 poorten (voor hulpstukken),
- tien 10 mm poorten (voor hulpstukken, zoals keerschotten, etc.),
- twee 12 mm poorten (voor hulpstukken zoals een oogstpijp, etc.).

! Let op:

Het is zeer aan te bevelen om het reactordeksel te aarden om ruis op de electrodesignalen te voorkomen (statische electriciteit); gebruik hiervoor een van de twee 2 mm gaatjes in het deksel.

Het andere gaatje kan dan gebruikt worden voor de aansluiting van de niveauregeling.

1.4 DE ROERDER:

Twee verschillende typen roerders zijn beschikbaar voor toepassing in bioreactoren:

Z81315R003: Lipseal roerder 2, 3, 5 liter

Z81315R007: Lipseal roerder 7 liter

Z81315MG03: Magnetisch gekoppelde roerder 2, 3, 5 liter

Z81315MG07: Magnetisch gekoppelde roerder 7 liter

Materiaal: roestvast staal 316.

De roerders zijn volledig autoclaveerbaar en ontworpen voor lange gebruiksperiodes met een minimum aan onderhoud.

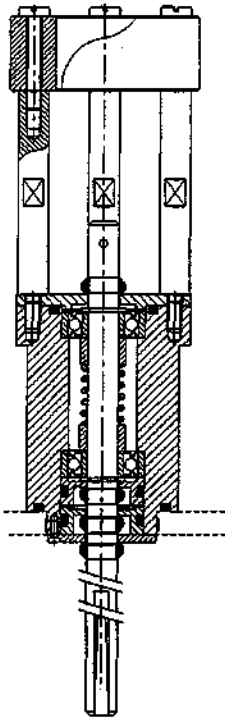

Lipseal roerder

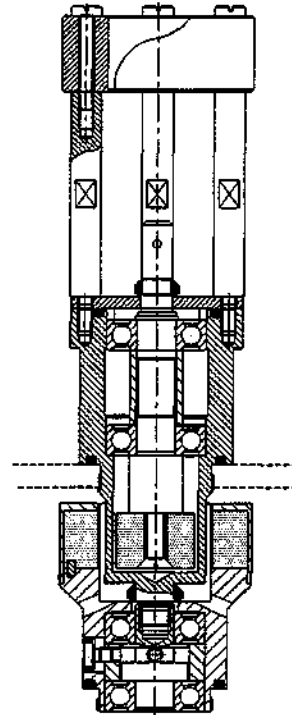

Magn. gekoppelde roerder (zonder as)

De roeras van de lipseal roerder is direct gekoppeld aan de roermotor die op de roerder wordt geplaatst. Dit is de meest gebruikte benadering, waarbij infectiegevaar wordt voorkomen door een viertal viton afdichtingen (lipseals).

De magnetisch gekoppelde roeras daarentegen is special ontworpen voor toepassing bij genetisch onderzoek en dierlijke celkweek. Dit ontwerp bevat geen bewegende afdichtingen tussen de reactor en de omgeving waardoor veilig gebruik gegarandeerd wordt.

De toe te passen roermotoren staan beschreven in de gebruiksaanwijzing van de roermotoren.

HOOFDSTUK 2

ROEREN EN BELUCHTEN

Om te komen tot een optimaal gedrag van een willekeurig biologisch systeem, is het noodzakelijk de omgeving van het micro-organisme in optimale conditie te houden. Naast temperatuur en mediumsamenstelling, zijn de twee meest belangrijke factoren die de omgevingsconditie beïnvloeden de mate van roeren en beluchten.

In de Engelse versie van deze gebruiksaanwijzing wordt uitgebreid aandacht besteed aan de theoretische en praktische kanten van deze materie; tevens kunt u in getalvorm gegevens vinden ten aanzien van mengtijden en snelheid van zuurstofoverdracht voor de hele range van de Applikon autoclaveerbare reactoren.

HOOFDSTUK 3

GEBRUIK

3.1 ALGEMEEN:

Controleer bij het uitpakken van de reactor of er geen transportschade aan het systeem is aangericht en of het compleet (in overeenstemming met de order) is afgeleverd.

Reinig alle delen met 70% ethanol. Wees voorzichtig bij het in elkaar zetten van de reactor en bijgeleverde hulpstukken om zodoende schade aan de poorten met schroefdraad te voorkomen; monteer de hulpstukken altijd vertikaal in het deksel en draai de bevestigingsringen slechts handvast aan.

Let op dat de O-ring aanwezig is tussen het hulpstuk en het reactordeksel om zodoende steriliteit te garanderen.

3.2 KLAARMAKEN VOOR STERILISATIE:

Vul het vat met kweekmedium; overschreid hiermee niet het maximum volume dat in hoofdstuk 1 wordt gegeven (hardware specificatie). Reserveer voldoende volume voor toevoegingen na sterilisatie (zoals inoculatie vloeistof, apart gesteriliseerde nutriënten, en dergelijke).

Draai de zes kartelmoeren op het deksel kruiselings handvast aan.

Controleer of de elektroden goed functioneren (vul het electroliet van de pH-electrode bij). Steek de "niveau-sensor" zo ver mogelijk in de reactor en zet deze vast (na sterilisatie kan deze op het juiste niveau naar boven toe worden bijgesteld).

Controleer de bevestiging van alle hulpstukken. Sluit de slangen voor toevoegingen aan, zoals vloeistoffen, lucht-in en lucht-uit; gebruik hiervoor siliconenslang of ander steriliseerbaar materiaal.

Gebruik voor dit doel geschikte luchtfilters voor in- en uitgaande lucht. Sluit de slang tussen deksel en het luchtinlaatfilter af met een slangenklem om te voorkomen dat het filter van binnen nat wordt tijdens de sterilisatie.

Sluit alle andere aansluitingen af met uitzondering van de luchtuitlaat; via het filter kan er zo drukevenwicht tot stand komen tijdens sterilisatie. Vul alle open slanguiteinden met een wattenprop en bedek deze met aluminiumfolie tegen het nat worden.

De warmtewisselaar dient leeg te zijn.

3.3 STERILISATIE:

De bioreactor met alle hulpstukken (met uitzondering van de roermotor) kan in een autoclaaf geplaatst worden. De ruimte die hiervoor nodig is kan worden afgeleid van de maten op de tekeningen in de Engelse versie van dit manual.

De autoclaaf dient minimaal 20 minuten op een temperatuur van 121°C gehouden te worden om alle levende organismen en hitte-resistente sporen te doden.

Laat de autoclaaf na sterilisatie zonder te openen afkoelen tot beneden de 90°C. Daarna kan de autoclaaf worden geopend om verder af te koelen.

N.B.:

In geval van reactoren met een mantel kan het nodig zijn om het sterilisatieinterval te verlengen aangezien de warmte-uitwisselingscapaciteit van een lege mantel gering is.

Indien het medium een langer interval niet kan verdragen, kan de mantel gevuld worden met water om op die manier de warmte-uitwisseling te verbeteren (sluit de onderste connector aan en klem de slang af, laat de bovenste aansluiting open voor drukevenwicht).

3.4 INSTALLATIE:

Zet de reactor zo dicht mogelijk naast de regelapparatuur (de Bio Processor of Bio Controller) en sluit de elektroden aan. Sluit de warmtewisselaar aan op het waterbad en de lucht-inlaatpijp en eventuele zuurstof/stikstof-inlaat op de voorziening-voor-gassen; maak verder alle aansluitingen die in uw specifieke configuratie noodzakelijk zijn. Verbind de sterile vloeistoffen die moeten worden toegevoegd, op aseptische wijze met de invoerpijpjes.

Vul de thermometerhouder met water of siliconenolie om de warmte-uitwisseling tussen het medium en de thermometer te verbeteren; hierdoor wordt de temperatuurregeling nauwkeuriger. Wanneer gewerkt wordt bij hogere temperaturen, dan heeft siliconenolie het voordeel dat het een lagere dampspanning heeft (minder verdamping).

3.5 KLAARMAKEN VOOR GEBRUIK:

Wanneer alle kabels en slangen aangesloten zijn, kunnen de regelaars ingeregeld worden op de optimale proceswaarde (temperatuur, pH, dO₂, etc.).

Schakel het waterbad (verwarmingselement) in en zet de roerder en andere aandrijvingen (zoals pompen e.d.) aan; open de toevoer van gassen.

Nadat de ingestelde waarden bereikt zijn en de reactor hierop is gestabiliseerd, kan de inoculatie (enting) plaatsvinden.

3.6 ENTING:

Er zijn verschillende manieren om een reactor te enten; de twee meest gebruikte methoden worden hieronder beschreven:

1. Vul een steriele fles, waarop een steriele slang is aangesloten, met entvloeistof. Het andere eind van de slang wordt aangesloten op een steriele naald. Sluit de beluchting van de reactor af, prik de naald door het septum en breng de entvloeistof over naar de reactor door middel van zwaartekracht of een pomp.
2. Vul een steriele injectiespuit met entvloeistof; prik de naald door het septum en injecteer de vloeistof (deze methode is geschikt voor ent-volumina tot 100 ml).

Ook andere ent-methoden kunnen worden gebruikt zolang deze aseptisch worden uitgevoerd.

3.7 ACTIES TIJDENS FERMENTATIE:

- **Monstername:**

Verbindt een monsternamesysteem met de monsternamepijp. Sluit hierop (via een slang met een filter of een wattenprop) een injectiespuit aan.

Trek aan de plunjer van de injectiespuit, waardoor onderdruk ontstaat in het monsternamesysteem. Als gevolg wordt een deel van de reactorinhoud in het monsternamesysteem gezogen.

Vervang de monsternamefles op aseptische wijze door een gesteriliseerde lege fles.

- **Toevoegingen:**

Indien extra substraat toegevoegd moet worden tijdens de kweek, dan kan dit gedaan worden op analoge wijze als beschreven onder 3.6 (Enting).

Controleer of er voldoende ruimte is in de reactor om de toevoeging uit te voeren.

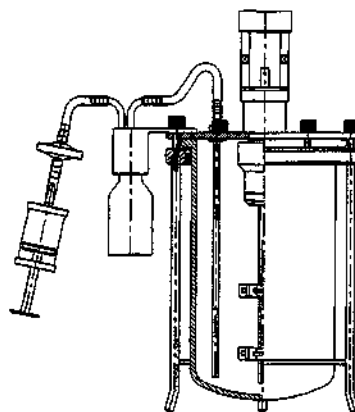

3.8 PASTEURISATIE:

Na de fermentatie kan de kweek worden gepasteuriseerd om de organismen te doden. Dit wordt gedaan door de sterilisatie-procedure te volgen; stel de temperatuur van de autoclaaf in op circa 80°C.

Na pasteurisatie kan het deksel van de reactor worden verwijderd en de kweek kan worden geoogst.

HOOFDSTUK 4

ONDERHOUD

4.1 DE REACTOR EN HET DEKSEL:

Na beëindiging van het fermentatieproces dienen de glazen en roestvast stalen onderdelen grondig te worden gereinigd. Gebruik hiervoor heet water, 70% ethanol of andere geschikte reinigingsmiddelen. Gebruik nooit schuurmiddelen om de metalen onderdelen te reinigen.

Laat de onderdelen drogen en zet de reactor weer in elkaar. Let op: vergeet geen O-ringen en zorg ervoor dat ze niet beschadigd worden, aangezien dit tot infectie kan leiden tijdens de volgende kweek.

Wanneer de reactor regelmatig gebruikt wordt, is het aan te raden om de O-ringen van de hulpstukken twee maal per jaar te vervangen.

N.B.:

Zorg dat de pH-electrode grondig wordt schoongemaakt voordat hij wordt opgeborgen; volg de voorschriften in de gebruiksaanwijzing van de electrode.

4.2 DE ROERDER:

De roerder dient twee maal per jaar uit elkaar genomen en onderhouden te worden. Instructies hiervoor staan hieronder vermeld.

4.2.1 LIPSEAL ROERDER:

- Verwijder het deksel van de reactor en verwijder de roervinnen van de roeras. Schroef de roerder uit het deksel.
- Verwijder de koppelingsring (A) door de vier schroeven te verwijderen.
- Schroef de pennen (B) los waarop de koppelingsring was bevestigd en verwijder de "spring pin" (C) en de bovenste lipseal (D).
- Verwijder de bovenplaat (E).
- Verwijder de onderplaat (H) door de drie kleine schroeven los te schroeven en lipseal te verwijderen.
- Verwijder borgveer (G) die kogellager (F) op zijn plaats houdt.
- Zet de roerder op zijn kop en duw de as langzaam uit het kogellagerhuis. Dit gaat het meest gemakkelijk door de roeras (op zijn kop) op een tafel te zetten en het kogellagerhuis naar beneden te drukken.
- Reinig alle onderdelen en smeer de kogellager met hiervoor speciaal beschikbaar vet (art. no. V3LA120031).
Vervang zonodig O-ringen en/of lipseals en zet de roerder weer voorzichtig in elkaar; volg deze instructie in omgekeerde volgorde.

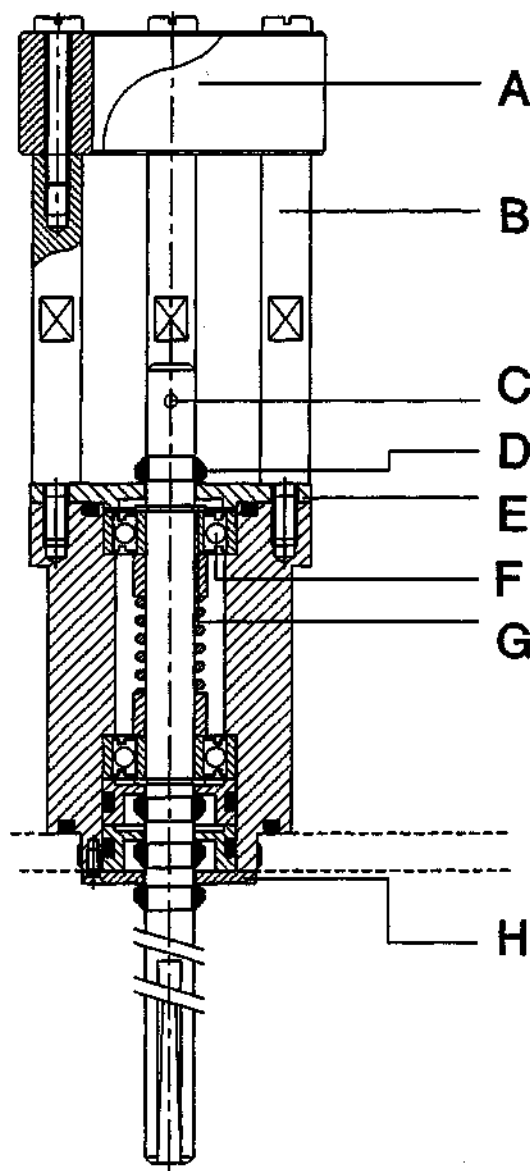

4.2.2 MAGNETISCH GEKOPPELDE ROERDER:

- Verwijder het deksel van de reactor en zet deze ondersteboven neer.
- Draai de ontmantelingsschroef (A) zo ver mogelijk naar binnen. Verwijder het onderste deel van de roerder door de rotor (B) tegen de klok in te draaien. Verwijder de rotor voorzichtig; denk om het magnetisch veld!
- Schroef de roerder uit het deksel.
- Neem de roerder uit elkaar door de bovenste vier schroeven los te maken en de pennen (C) los te schroeven. Trek de "spring pin" (D) uit de as en verwijder de bovenste lipseal (E). Neem de bovenplaat (F) weg.
- Trek de roeras en de binnenmagneet uit de behuizing.
- Reinig alle onderdelen met celstof, smeer de kogellagers (G) met speciaal hiervoor beschikbaar vet (art. no. V3LA120031).
- Verwijder de roeras van de rotor (B); reinig en smeer het oppervlak van de kogellager (G).
- Vervang zonodig O-ringen of lipseals en zet de roerder weer voorzichtig in elkaar; volg deze instructie in omgekeerde volgorde.

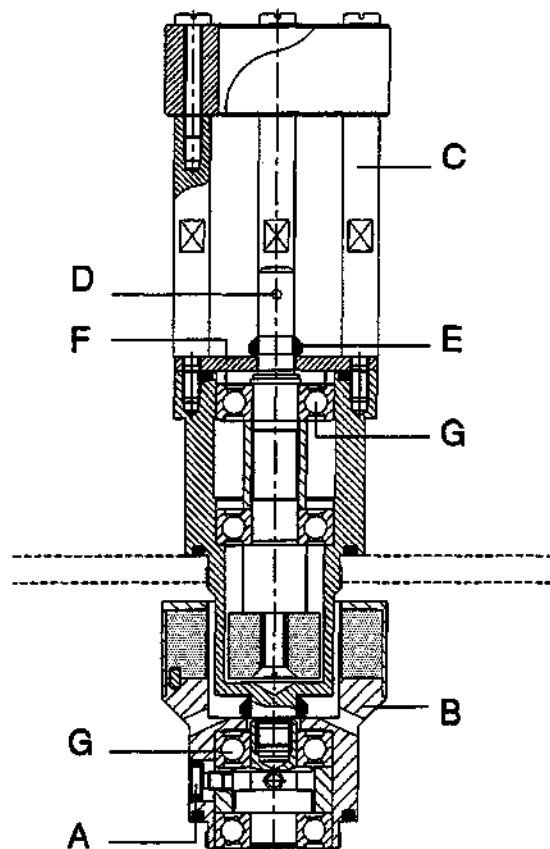

4.3 HULPSTUKKEN EN RESERVEONDERDELEN:

In de Engelse versie van dit manual is een opsomming te vinden van alle toepasbare hulpstukken (hoofdstuk 5) en lijsten met reserveonderdelen (hoofdstuk 6).

AUTOCLAVABLE BIOREACTOR

2 - 7 LITER

USER MANUAL



TABLE OF CONTENTS

Chapter	Description	Page
1	Hardware specification	1-1
1.1	General	1-1
1.2	The reactors	1-2
1.3	The head plates	1-7
1.4	The stirrer assemblies	1-9
2	Mixing and aeration	2-1
2.1	Mixing	2-1
2.2	Aeration	2-6
2.3	Literature	2-9
3	Operation	3-1
3.1	General	3-1
3.2	Preparing for sterilization	3-1
3.3	Sterilization	3-2
3.4	Installation	3-2
3.5	Preparing for operation	3-2
3.6	Inoculation	3-3
3.7	Actions during fermentation	3-3
3.8	Pasteurization	3-3
4	Maintenance	4-1
4.1	The reactor	4-1
4.2	The stirrer assembly	4-2
5	Auxiliaries	5-1
5.1	Sampling	5-1
5.2	Aeration	5-6
5.3	Addition	5-9
5.4	Mixing	5-11
5.5	Heat exchangers	5-14
5.6	Sensor holders	5-15
5.7	Blind stoppers	5-16
6	Drawings	6-1



CHAPTER 1

HARDWARE SPECIFICATION

1.1 GENERAL:

The stirred tank reactors (STR) are the most applied reactor types in biotechnology.

The Applikon 2 - 7 liter autoclavable bioreactors offer several advantages; its modular and flexible design requires minimum bench space and is very practical in operation.

In combination with Applikons stirrer assemblies, motors, impellers and auxiliaries, you can configure the reactor for a variety of applications, like:

- medium optimization,
- screening of strains,
- product optimization,
- scale up/down studies,
- reactor optimization,
- continuous cultures,
- perfusion systems, etc.



Danger:

Glass is a material that may be damaged easily (scratches on the surface)! As a result, its strength is reduced. Therefore do not apply a process pressure that exceeds 50 kPa (0.5 bar, 7 psig).

Reduce the pressure of the inlet gasses to this extend or apply a pressure relief that is properly adjusted.

1.2 THE REACTORS:

The 2 - 7 liter bioreactors are ideal tools for researchers who start fermentation studies and for those applications where small or medium volumes are required.

Due to the modular design, the reactors can be used for a variety of applications, including microbial and yeast fermentations, cell cultures, etc.

Reactor material: borosilicate glass.
 Other materials in contact with the medium: stainless steel (head plate),
 silicone rubber,
 viton and EPDM.

The reactor types and their specifications are listed below.

- The 2 l dished bottom bioreactor Z611020002:
 Specifications:
 Maximum working volume : 2.2l (H/D ratio = 2.3)
 Minimum working volume : 0.5l
 Working volume : 1.7l (H/D ratio = 1.9)

For temperature control, a heat exchanger inside the reactor can be used or a silicone heating blanket can be wrapped around the vessel. The reactor comes with a tripod for support.

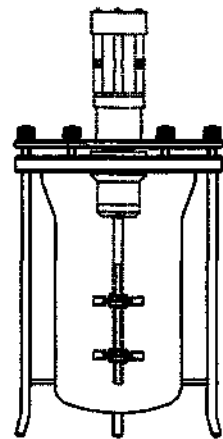

- The 2 l jacketed bioreactor Z61104CT04:
 Specifications:
 Maximum working volume : 2.2l (H/D ratio = 2.3)
 Minimum working volume : 0.5l
 Working volume : 1.7l (H/D ratio = 1.9)
 Jacket volume : 1.3l

The jacketed reactor is especially developed for mammalian cell cultures; the large heat transfer area ensures optimum conditions for temperature control.

The tripod is supplied with extension shafts.

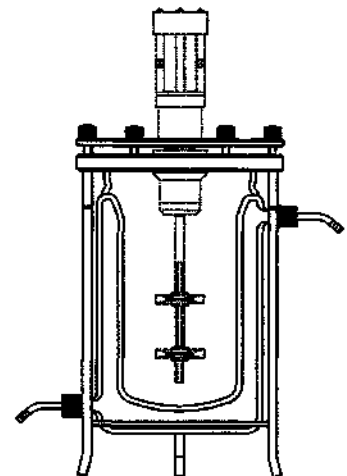

- The 3 l flat bottom bioreactor Z611000004:
This reactor is generally used for bacterial fermentations with micro organisms that are not very sensitive to shear forces.

Specifications:

Max. working volume : 3.2l (H/D ratio = 1.8)
Min. working volume : 0.44l
Working volume : 2.6l (H/D ratio = 1.5)

A heat exchanger, inside the vessel, or a silicone heating blanket, wrapped around the vessel, can be used for temperature control.

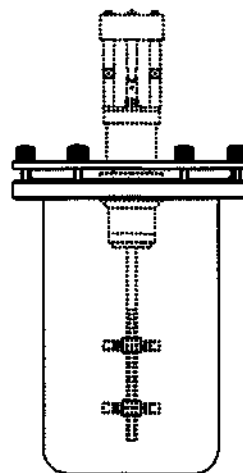

- The 3 l dished bottom bioreactor Z61101C006:
This reactor is mostly used for culturing shear sensitive cells/organisms. The dished bottom ensures optimum mixing properties.

Specifications:

Total volume : 3.2l (H/D ratio = 1.9)
Minimum working volume : 0.47 ml
Working volume : 2.7l (H/D ratio = 1.5)

Temperature control can be obtained in the same way as with the 3 l flat bottom bioreactor.

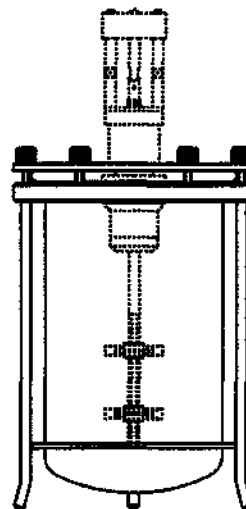

- The 3 l jacketed bioreactor Z61103CT04:
 This reactor has the same specifications as the 3 l
 dished bottom reactor; however, temperature control is
 performed through the glass jacket. In this way, the
 temperature can be controlled more accurately; the
 jacket can both be used for heating and cooling.

Internal jacket volume : 1.3l

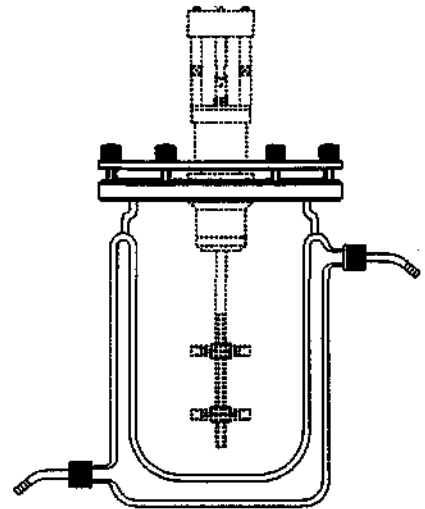

- The 5 l dished bottom bioreactor Z611000005:
 Specifications:
 Max. working volume : 4.8l (H/D ratio = 1.6)
 Min. working volume : 2l
 Working volume : 3.4l (H/D ratio = 1.1)

For temperature control, a heat exchanger inside the reactor
 can be used or a silicone heating blanket can be wrapped
 around the vessel. The reactor comes with a tripod for
 support.

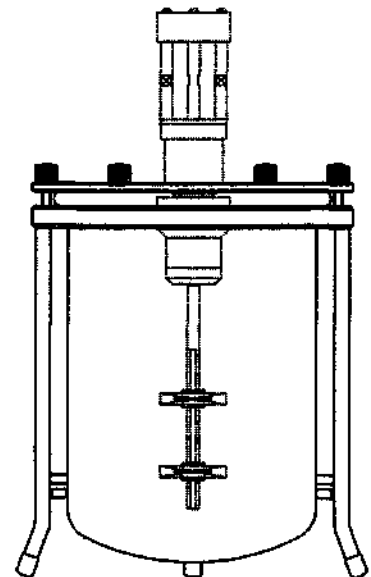

- The 5 l jacketed bioreactor Z61104CT05:
This reactor has the same specifications as the 5 l dished bottom reactor; however, temperature control is performed through the glass jacket.

Jacket volume : 2.8l

The jacketed reactor is especially developed for mammalian cell cultures; the large heat transfer area ensures optimum conditions for temperature control.

This reactor has a tripod for support.

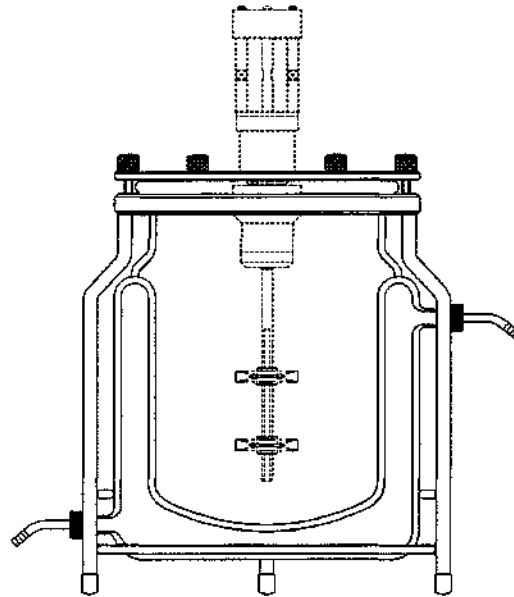

- The 7 l dished bottom bioreactor Z611000007:
Specifications:
Max. working volume : 6.9l (H/D ratio = 2.2)
Min. working volume : 2.0l
Working volume : 5.4l (H/D ratio = 1.8)

For temperature control, a heat exchanger inside the reactor can be used or a silicone heating blanket can be wrapped around the vessel. The reactor comes with a tripod for support.

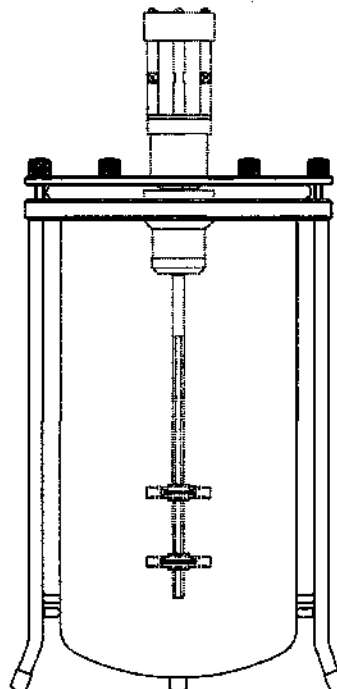

- The 7 l jacketed bioreactor Z61103CT07:
This reactor has the same specifications as the 7 l dished bottom reactor; however, temperature control is performed through the glass jacket.

Jacket volume : 4.2l

The jacketed reactor is especially developed for mammalian cell cultures; the large heat transfer area ensures optimum conditions for temperature control.

This reactor has a tripod for support (tripod of the 5 liter reactor with extension shafts).

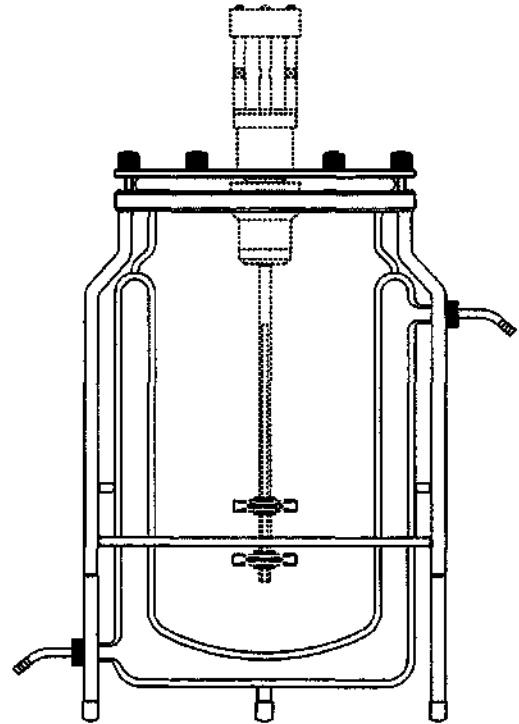

1.3 THE HEAD PLATES:

The head plates are made of stainless steel 316. The port lay-outs are presented in the figures below:

The 2 liter reactor:

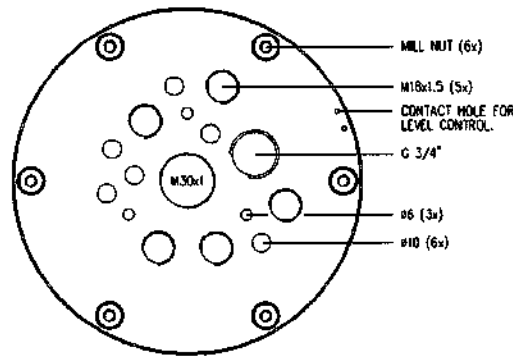

The following ports are present:

- one central M 30 x 1 port (for the top stirrer),
- one G3/4" port (for dissolved oxygen sensor),
- five M 18 x 1.5 ports (for auxiliaries),
- three 6 mm ports (for baffles or other auxiliaries),
- six 10 mm ports (for auxiliaries).

The 3 liter reactor:

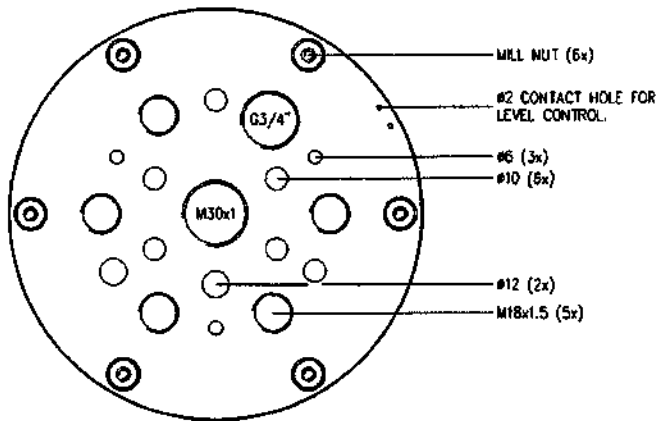

The following ports are present:

- one central M30 x 1 port (for the stirrer assembly),
- one G3/4" port (for dissolved oxygen sensor),
- five M18 x 1.5 ports (for auxiliaries like other sensors (pH, mV), etc.),
- two 12 mm ports (for auxiliaries like harvesting pipes, etc.),
- six 10 mm ports (for auxiliaries like air inlet pipes, etc.),
- three 6 mm ports (for baffles, etc.).

The 5 and 7 liter reactor:

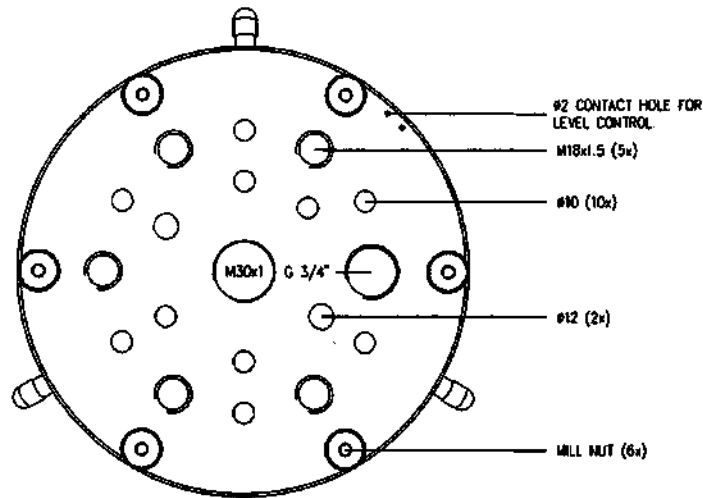

The following ports are present:

- one central M 30 x 1 port (for the stirrer assembly),
- one G3/4" port (for the dissolved oxygen sensor),
- five M 18 x 1.5 ports (for auxiliaries like other sensors (pH, mV), etc.),
- two 12 mm ports (for auxiliaries like harvesting pipes, etc.),
- ten 10 mm ports (for auxiliaries like baffles, air inlet pipes, etc).



Caution:

It is strongly advised to ground the head plate in order to avoid disturbances on electrode/sensor signals (static electricity); use one of the two 2 mm holes in the head plate. The other 2 mm hole can be used for level control connection.

1.4 THE STIRRER ASSEMBLY:

Two different stirrer assembly types are available: a lipseal stirrer assembly and a magnetically coupled stirrer assembly .

Z81315R003: Lipseal stirrer assembly 2, 3, 5 liter

Z81315R007: Lipseal stirrer assembly 7 liter

Z81315MG03: Magnetically coupled stirrer assembly 2, 3, 5 liter

Z81315MG07: Magnetically coupled stirrer assembly 7 liter

Material: stainless steel 316.

The assemblies are autoclavable and are designed for long periods of operation with minimum maintenance.

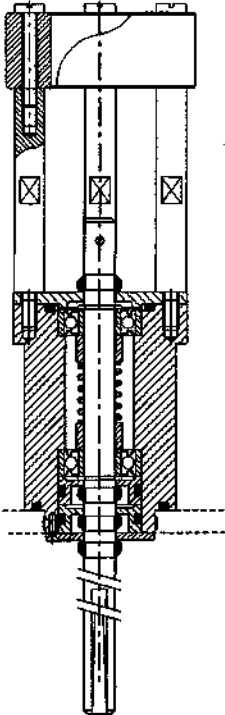

Lipseal stirrer assembly

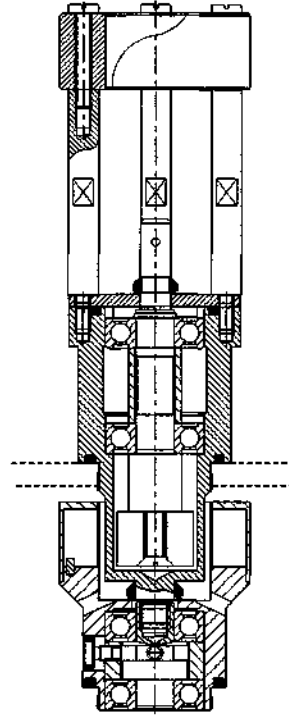

Magn. coupled stirrer assembly (ex. shaft)

The stirrer shaft of the lipseal stirrer assembly is coupled directly to the stirrer motor. This is the most common way of coupling, whereby contamination-free operation is ensured by the use of viton lipseals.

The magnetically coupled stirrer assembly is especially developed for applications concerning genetic engineering organisms and cell culture. This ensures absolute contamination-free operation since there is no moving seal between the reactor content and the environment.

The applicable stirrer motors are described in the stirrer motor manual.

HARDWARE SPECIFICATION

USER MANUAL
Autoclavable Bioreactor 2 - 7 liter
October 1994

CHAPTER 2

MIXING AND AERATION

For an optimum performance of any biological system, it is necessary to keep the environment of the micro-organisms at optimal conditions. Apart from temperature and medium composition, the two most important factors that effect this environment are the degree of mixing and aeration.

2.1 MIXING:

The aim of mixing is to obtain uniform conditions in the working volume of the bioreactor, in order to obtain an optimal mass transfer, to avoid gradients of any of the medium components, and to keep the microcarriers or cells in suspension. In a normally used stirred tank reactor, mixing is accomplished by the impeller. The resulting flow pattern is a function of the impeller configuration, agitation speed, the geometry of the system and gas inflow rate employed.

One aspect of mixing is preventing the cells or microcarriers to settle. In order to achieve this, the fluid velocity must at least be equal to the settling velocity of the particles (v_{sett}), which can be calculated according to Stokes' law (Cherry and Papoutsakis, 1986):

$$v_{sett} = d_p^2 \cdot (\rho_s - \rho_f) \cdot g / (18 \cdot \eta)$$

where:

d_p	= particle diameter (m),
ρ_s	= particle density (kg m^{-3}),
ρ_f	= medium density (kg m^{-3}),
g	= gravitational constant (m s^{-2})
η	= medium viscosity (N m s^{-1}).

Stokes' law only holds for particles whose Reynolds numbers are smaller than 1 (which holds for all normally used biological systems). As the biomass should be homogeneously distributed throughout the reactor, not only must the particles be lifted from the bottom of the vessel but they must also be transported through the whole volume of the reactor.

Generally, the minimum required stirring speed to achieve homogeneous suspension, N_{hs} , is much greater than that to lift the particles from the bottom of the reactor. Buurman et al. (1986) also derived a simple Froude relationship to define homogeneity in a stirred tank reactor (STR), based on the assumption of fluctuating velocity being proportional to the circulation velocity:

$$\rho_f N_{hs}^2 D_i^2 / (g \cdot (\rho_s - \rho_f) \cdot d_p) = \text{constant}$$

where: D_i = diameter of the impeller (m)

which implies that:

$$N_{hs} \sim 1/D_i$$

The parameter used to describe the medium homogeneity aspect of mixing is the mixing time, which is in fact also the characteristic time for mixing. The mixing time, t_m , is often expressed in the liquid circulation time, t_c . In the case of a stirred tank t_m equals 4 times t_c (Voncken, 1966).

The liquid circulation time in STRs with a Rushton impeller can be calculated according to (Oosterhuis, 1984):

$$t_c = V / (0.75 \cdot N \cdot D_i^3)$$

where: V = working volume of the reactor (m^3),
 N = rotation speed of the impeller (s^{-1}),

If the geometry of the system has to be taken into account in ungasged STRs the following correlation for the mixing time can be used:

$$t_m = 1.2 / N \cdot (D/D_i)^3 \cdot (H/D) \cdot N_p^{-1/3} \cdot (D_i/H_i)^{2/3}$$

where: D = diameter of the reactor (m),
 H = liquid height in the reactor (m),
 N_p = impeller power number (-),
 H_i = height of impeller blade (m).

The impeller power number is a constant for a given system and related to the power input by the stirrer (P_s) in the following way:

$$P_s = N_p \cdot \rho_f \cdot N^3 \cdot D_i^5$$

The mixing time in a gassed STR is, as a rule of thumb, twice as high as in an ungasged STR. The resulting mixing time in ADI's autoclavable bioreactors for mammalian cell and bacterial culture under average operating conditions (ungasged) is given in the following table.

Applikon Dependable Instruments Autoclavable Bioreactors: Mixing times									
Reactor configuration				Mammalian cell culture N=100rpm, Marine imp.			Bacterial culture N=1000rpm, Rushton imp.		
Reactor volume V (l)	Impeller diameter D _i (mm)	Reactor diameter D _r (mm)	Liquid height H (mm)	impeller power no N _g	Impeller height H _i (mm)	Mixing time t _m (sec)	Impeller power no N _g	impeller height H _i (mm)	Mixing time t _m (sec)
1	45	96	150	3	28	1.3	6	11	0.2
2	45	115	125	3	28	1.6			
2	45	105	175				12	11	0.2
3	45	130	200	3	28	3.2	12	11	0.4
5	60	170	200	3	37	2.8	12	15	0.3
7	60	170	300	6	37	3.4	18	15	0.4
15	74	222	365	6	45	4.3	18	15	0.5
20	74	222	550	9	45	5.7	18	19	0.8

Measurements of the mixing time in a two and three liter reactor have shown to comply well with these correlations (Kakes and Oosterhuis, 1990). It is obvious from this table that the mixing times are very small in relation to the characteristic times that are to be expected for the metabolism (e.g. oxygen uptake rate, substrate consumption rate) of the micro-organisms. Therefore the medium can be looked upon as being ideally mixed at all times during fermentation.

As the bubbles are coalescing behind the impeller and broken up by vortices created by the impeller, the gas will be homogenised in a similar way as the medium and its components. The influence of gas feed on this mechanism is illustrated in the figure below (Warmoeskerken, 1986). Despite this mixing of the gas phase, the cavities behind the impeller blades will decrease the power input to the reactor and thus decrease the oxygen transfer rate to the reactor medium (see chapter 2.2: aeration).

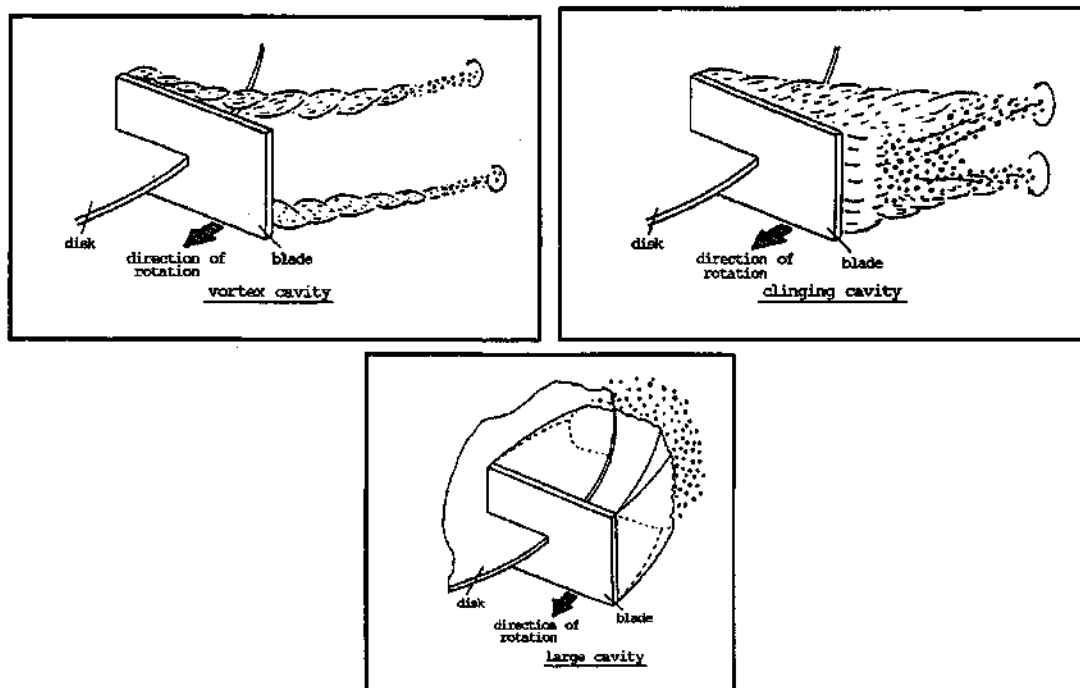

Cavity shape behind Rushton type impellers for small, medium and high gas feed rates.

The operating range of the impeller speed is limited due to the potential damaging effect of the rotating impeller on the micro-organisms. Therefore, it may be impossible to satisfy the criteria for homogeneity. Furthermore, a Rushton type of impeller will only create a homogeneous distribution of bubbles throughout the reactor at relatively high rotation speed (>500 rpm, see figure below, Nienow et al., 1977). Differences in sensitivity to damaging by the impeller and oxygen requirements between bacteria, fungi and mammalian cells have led to the development of various types of impellers. To improve the axially mixing characteristics of the Rushton impeller, impellers with angled blades have been developed. To reduce the damaging effect of the impeller, the (angled) blades are curved in order to create a marine type of impeller for application in mammalian cell or fungi cultures. This impeller also has a good axially pumping capacity which ensures mixing of the complete reactor medium and improves refreshment of the topmost layer of liquid to achieve higher oxygen transfer rates without sparging (see chapter 2.2: aeration).

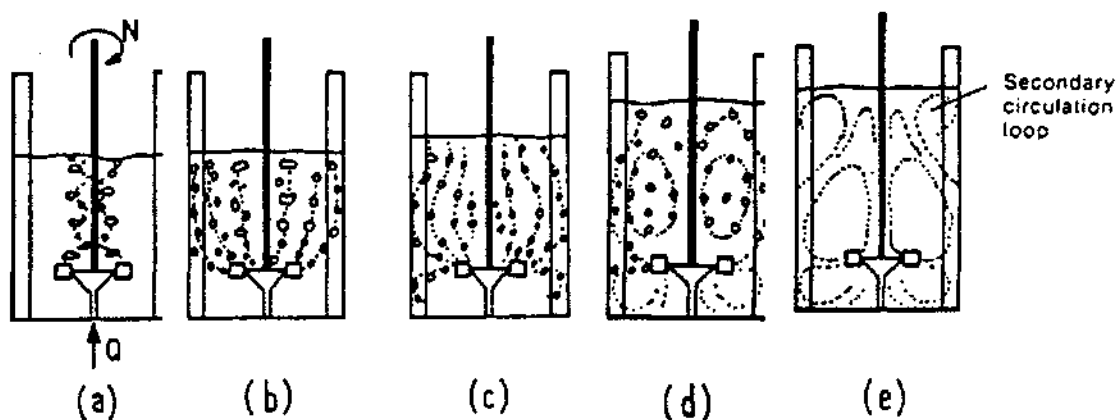

Gas circulation patterns in aerated stirred vessels at increasing stirring speed (constant gas feed).

2.2 AERATION:

Gas-liquid mass transfer in cell culture systems is governed by the solubility of the gas in the liquid medium (Bliem and Katinger, 1988), its molecular diffusivity and the driving force of the gas (which vary with temperature and pressure), and may be described by the expression:

$$\text{OTR} = k_L a \cdot (O^* - O_1)$$

- where: OTR = oxygen transfer rate,
 k_L = liquid phase mass transfer coeff.,
 a = gas-liquid interfacial area per unit liquid volume,
 O^* = liquid phase oxygen concentration in equilibrium with the bulk gas phase (at 1 atm and 37°C: 0.18 mmol O₂/l).
 O_1 = actual oxygen concentration of the liquid phase.

The term $k_L a$ represents the volumetric overall mass transfer coefficient and is one of the most common parameters used to describe the efficiency of an aeration system. Bliem and Katinger (1988) compared the typical efficiency of some forms of aeration which are given in the following table.

Efficiencies of different aeration systems		
Typical oxygen transfer rates under culture conditions, using air (cm s ⁻¹)	$k_L a$ (s ⁻¹)	Aeration system
10 ⁻⁶	10 ⁻⁶	static liquid surface aeration.
10 ⁻⁶ - 10 ⁻³	10 ⁻⁶ - 10 ⁻³	stirred liquid surface aeration.
10 ⁻⁵ - 8 * 10 ⁻⁵	10 ⁻⁴ - 10 ⁻²	silastic membrane aeration.
5 * 10 ⁻⁵ - 3 * 10 ⁻⁴	10 ⁻⁴ - 3 * 10 ⁻⁴	dynamic wire mesh (with agitation).
	< 7 * 10 ⁻³	sparged and stirred liquid for cell culture.
	10 ⁻² - 7 * 10 ⁻¹	sparged and stirred liquid for microbial culture.

The k_a -values are strongly influenced by the medium composition. For example, the addition of silicone antifoam can cause the k_a to decrease drastically whereas the addition of salts to the medium will increase the k_a (Lavery and Nienow, 1987; Bliem and Katinger, 1988).

For a mammalian cell culture to a density of $5 \cdot 10^9$ cells/l (a typical batch culture), the oxygen requirement is in the range of 5-50 ml O_2 /l·h (at 37°C and atmospheric pressure). Therefore, the required k_a for a typical batch culture operation is likely to be $0.5-5 \cdot 10^{-4} s^{-1}$. Static liquid surface aeration is insufficient even for these low requirements (see table on previous page). For high density cultivation, as reached in long-term perfusion systems, the required k_a may increase to as much as $0.1-1 \cdot 10^{-2} s^{-1}$; this oxygen requirement can only be supplied by sparging.

Sparging is the most efficient way to obtain high k_a values. Most experimental data for k_a values can be estimated by the correlations of Van 't Riet (1979) and Henzler (1982) (adapted for temperature difference):

for coalescing media:

$$k_a = (1.022^{(T-20)}) \cdot 0.026 \cdot (P_g/V)^{0.4} \cdot v_s^{0.5}$$

for non-coalescing media:

$$k_a = (1.022^{(T-20)}) \cdot 0.016 \cdot (P_g/V)^{0.7} \cdot v_s^{0.2}$$

where: T = temperature (°C),
 P_g = the gassed power input by impeller ($N m s^{-1}$),
 V = volume (m^3),
 v_s = superficial gas velocity ($m s^{-1}$).

At very low aeration rates P_g will be equal to the ungassed power input P_s (Lavery and Nienow, 1987) but at higher aeration rates the gassed power input has to be calculated according to:

$$P_g \approx 0.5 \cdot P_s = 0.5 \cdot N_p \cdot \rho_f \cdot N^3 \cdot D_i^5$$

The theoretical k_a values from these correlation for ADI's autoclavable reactors are given in the table below. Measurements of k_a values on a two and three liter scale have shown that the oxygen transfer capacity that can be reached in practice is upto 10 times higher (Kakes and Oosterhuis, 1990). Sparging, however, is known to cause inadmissible shear stress for mammalian cells, will increase the problem of foam formation in bacterial as well as mammalian cultures and is, therefore, limited in its applications.

Applikon Dependable Instruments Autoclavable Bioreactors: Theoretical oxygen transfer rates.								
Reactor configuration			Mammalian cell culture, N=100 rpm, Marine impellers, Aeration = 0.05 vvm.			Bacterial culture, N=1000 rpm, Rushton impellers, Aeration = 1 vvm.		
Reactor volume V (l)	Impeller diameter D, (mm)	Reactor diameter Dr (mm)	Impeller power no N_p	Oxygen transfer		Impeller power no N_p	Oxygen transfer	
				coalesc. k_a (h^{-1})	non coal k_a (h^{-1})		coalesc. k_a (h^{-1})	non coal k_a (h^{-1})
1	45	96	3	1	18	6	7	33
2	45	115	3	1	12			
2	45	105				12	8	37
3	45	130	3	1	9	12	7	27
5	60	170	3	2	18	12	10	52
7	60	170	6	2	24	18	12	59
15	74	222	6	3	31	18	16	75
20	74	222	9	4	36	18	16	65

Since the required k_a value and admitted aeration flow vary widely from system to system, various ways are used to introduce a gas flow into the system.

For mammalian cell cultures mostly an (oxygen enriched) air overlay is used in combination with an axially pumping impeller. In order to get a large surface area and thus improve the oxygen transfer, reactors with a low H/D value (usually ≈ 1) are used for this application.

Fermentations that require both a low stirrer speed and gas flow need a sintered steel sparger in order to create small bubbles and thus a large area for oxygen transfer.

High gas flow rates can be reached with open pipes, or pipes with several relatively large holes.

All options are available for every ADI autoclavable bioreactor.

2.3 LITERATURE:

- Bliem, R. and Katinger, H. (1988) *Tibtech*, 6, 190-195 and 224-230.
- Buurman, C., Resoort, G. and Plaschkes, A. (1986) *Chem. Eng. Sci.*, 41, 2865.
- Cherry, R.S. and Papoutsakis, E.T. (1986) *Bioproc. Eng.*, 1, 29-41.
- Henzler, H.J. (1982) *Chem. Ing. Techn.*, 54, 461.
- Kakes, E. and Oosterhuis, N.M.G. (1990) A poster presentation on the Dutch Congress on Biotechnology.
- Lavery, M. and Nienow, A.W. (1987) *Biotechnol. Bioeng.*, 30, 368-373.
- Nienow, A.W., Wisdom, D.J. and Middleton, J.C. (1977) 2nd Eur. Conf. on Mixing, 30-3, Cambridge, England, Paper F1.
- Oosterhuis, N.M.G. (1984) Ph.D. Thesis, T.U. Delft, The Netherlands.
- Van 't Riet, K. (1979) *Ind. Eng. Chem. Proc. Des. Dev.*, 18, 367-375.
- Voncken, R.M. (1966) Ph.D. Thesis, T.U.Delft, The Netherlands.
- Warmoeskerken, M.M.C.G. (1986) Ph.D. Thesis, T.U. Delft, The Netherlands.

CHAPTER 3

OPERATION

3.1 GENERAL:

When unpacking the equipment, verify if there is any transport damage and if the reactor is complete (the way you ordered it). Clean all parts with 70% ethanol to remove dust or dirt from shipping. When assembling the reactor, make sure not to damage the threaded ports; always screw in the auxiliaries straight and by hand. Do not use tools to tighten the auxiliaries in the head plate.

Make sure that an O-ring is present between the auxiliary and the head plate in order to ensure sterility.

3.2 PREPARING FOR STERILIZATION:

Fill the vessel with culture medium, do not exceed the total volume that is specified in chapter 1 (hardware specification). Be sure to leave enough volume for additions after sterilization (e. g. inoculum, separately sterilized nutrients, etc.). Fasten the six mill nuts crosswise by hand. Verify the functioning of the electrodes (refill electrolyte of the pH electrode). Insert the Level probe as far as possible into the vessel and fasten it (after sterilization, the position of this probe can be adjusted, upward to the desired height).

Verify the mounting of all nipples and other auxiliaries. Make connections for liquid additions, air in and air out with silicone tubing or other suitable sterilizable material. Use appropriate filters for air in and air out. To avoid wetting of the inlet filter during sterilization, use a clamp to close the tubing between the head plate and the filter. Close all other connections (except the air out) air-tight with a hose and a hose clamp. Close all open tubing ends with cotton and cover the ends with sterilizable foil or paper.

Make sure that the vessel is not completely closed, since pressure differences during sterilization may damage the reactor or the probes. Use the air outlet filter to maintain pressure equilibrium in- and outside the reactor. The heat exchanger should be empty during sterilization.

3.3 STERILIZATION:

The bioreactor with all accessories (except the stirrer motor) can be placed in an autoclave. The space, needed in the autoclave can be derived from the drawings that are enclosed in the English copy of this manual.

The autoclave should stay at 121°C for at least 20 minutes in order to kill all organisms and thermo-resistant spores. After sterilization, let the autoclave cool down without opening it, until the temperature is below 90°C. When the temperature in the autoclave has dropped below 90°C, it can be opened to allow it to cool down further. This cooling procedure should be performed to avoid low pressure in any part of the reactor system. Low pressure in tubing might result in contamination when the tube is connected to a peripheral device. Low pressure in a pH-electrode may result in sudden boiling of the electrolyte.

Note:

In case of a jacketed reactor, the sterilization interval might need to be increased, since the empty jacket has a poor heat transfer capacity.

If the medium cannot stand a longer interval, you can fill the jacket with water to improve the heat transfer (connect and close the lower tube fitting, do not close the upper one).

3.4 INSTALLATION:

Put the reactor as near as possible to the control equipment (the Bio Processor or Bio Controller) and connect all electrodes to this equipment. Connect the heat exchanger to the thermo circulator; hook up the air inlet pipe to the flow console and, if present, connect cooling water to the condenser. Connect all sterile fluids (acid, base, etc.) that have to be added to the medium, aseptically to the inlet pipes.

To improve heat transfer between the thermometer pocket and the Pt100-sensor, fill the thermometer pocket with water or silicone oil. This will decrease the dead time of the sensor and will make your temperature control more accurate.

When operating at higher temperature, silicone oil has the advantage of a lower vapour pressure (less evaporation).

3.5 PREPARING FOR OPERATION:

After connecting all cables and tubing, adjust the setpoints of the controllers to the desired value (temperature, pH, DO₂, etc.).

Switch on the thermo circulator, stirrer motor, acid and/or base pumps and gas flow.

When temperature, pH etc. have reached their setpoint (and are stabilized), the bioreactor is ready for inoculation.

3.6 INOCULATION:

There are several ways to inoculate. Two methods that are commonly used are described here:

1. Fill a sterile flask, to which a sterile hose is connected, aseptically with inoculum. The other end of the hose should be connected to a sterile needle. Turn off aeration, pierce the needle through the septum and transfer the inoculum to the reactor by gravity feed or by using a pump.
2. In this case a sterile syringe is filled with inoculum. The needle is pierced through the septum and the inoculum is pushed into the reactor (this method is suitable for inoculum volumes smaller than 100 ml).

Other methods of inoculation can be used if they are performed aseptically.

3.7 ACTIONS DURING FERMENTATION:

- **Sampling:**

To sample a fermentation broth, a sample pipe is needed to which a sample system is attached. Connect a syringe to the tubing that is connected to the "out barb" of the sample system. In this tube there should be a filter or cotton. Pull the piston of the syringe to create a vacuum in the sample bottle. As a result, the fermentation broth is pulled into the sample bottle. Replace the sample bottle aseptically with a sterilized empty one.

- **Additions:**

If extra substrate is needed in the culture during fermentation, it can be added as described under "inoculation".

Make sure there is enough space left in your vessel for additions.

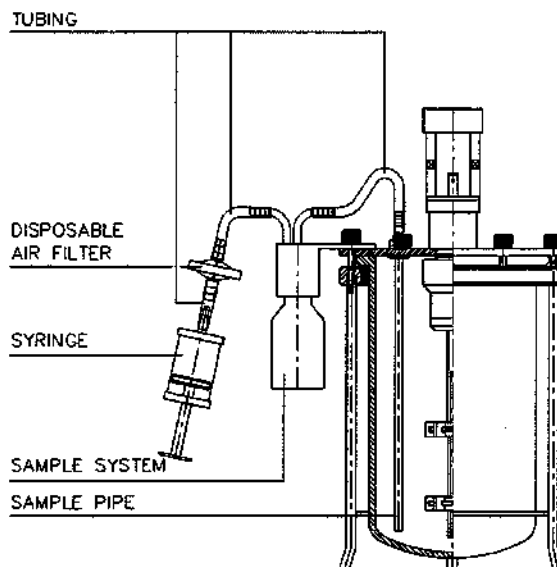

3.8 PASTEURISATION:

After fermentation, the broth can be pasteurized to kill the organisms.

To do this, follow the sterilization procedure, however the operating temperature of the autoclave should now be about 80°C.

After pasteurization, the head plate of the reactor can be removed and the fermentation broth can be collected.

CHAPTER 4

MAINTENANCE

4.1 THE REACTOR AND HEAD PLATE:

After finishing the fermentation process, the glass and stainless steel parts should be cleaned thoroughly.

Use hot water, 70% ethanol or other suitable cleaners to clean all parts. Never use abrasive materials to clean the metal parts.

After cleaning, dry the parts and reassemble the reactor. Take care not to damage or forget any O-rings, since this can cause contamination during the next run.

When the reactor is used frequently, it is advised to replace the O-rings of the auxiliaries twice a year.

Note:

Make sure that the pH-electrode is cleaned thoroughly before it is stored; refer to the user manual of this electrode.

4.2 THE STIRRER ASSEMBLY:

The stirrer assembly should be disassembled, cleaned and lubricated twice a year. Disassembling instructions are listed below:

4.2.1 LIPSEAL STIRRER ASSEMBLY:

- Remove the head plate from the reactor and remove the impellers from the stirrer shaft. Screw the stirrer assembly out of the head plate.
- Remove the coupling ring (A) at the top of the assembly by unscrewing the four slotted cheese head screws.
- Screw out the pillars (B) on which the coupling ring was mounted and remove the "spring pin" (C) and the upper lipseal (D). Take off the upper cover (E) of the stirrer assembly.
- Remove the lower cover (H) by loosening the three small screws and removing the lipseal.
- Remove the circlip (G) from the shaft (on top of the ball bearing (F)).
- Turn the stirrer assembly upside down, and gently push the shaft out of the ball bearing house. This is most easily achieved by placing the top of the stirrer shaft on the table (upside down) and pressing the housing down.
- Clean all parts and lubricate the ball bearing again with special grease (art. no. V3LA120031). Replace any O-ring or lipseal if necessary and reassemble the stirrer assembly carefully.

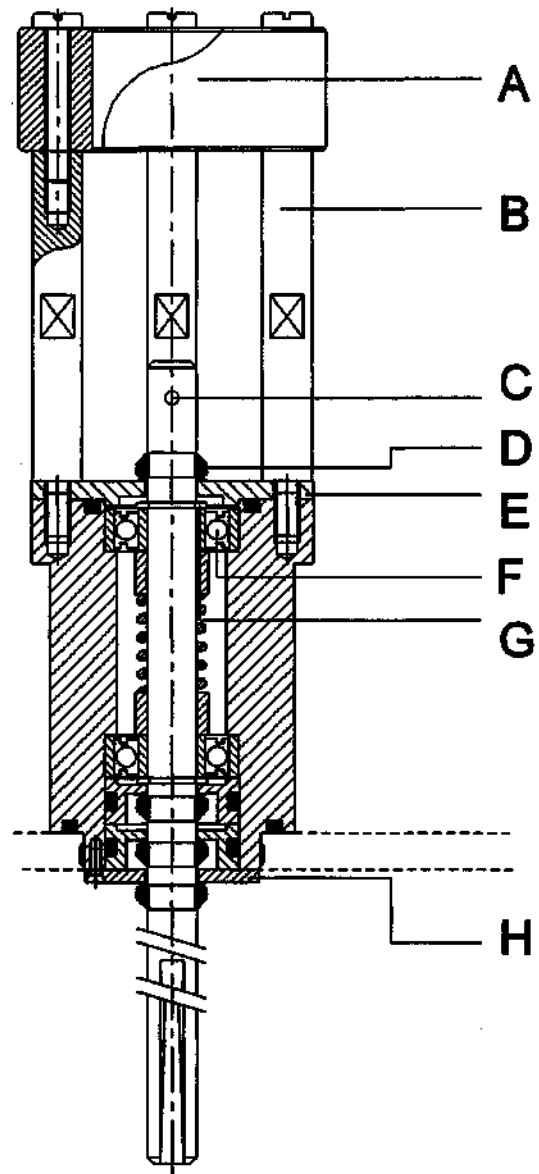

4.2.2 MAGNETICALLY COUPLED STIRRER ASSEMBLY:

- Remove the head plate from the reactor and put it upside down on the motor coupling ring of the stirrer assembly.
- Turn the dismantling screw (A) as far as possible into the housing. Loosen the lower part of the stirrer assembly by turning the rotor (B) counter clockwise. Pull off the lower part; be aware of the magnetic field.
- Remove the motor coupling part from the head plate by turning it counter clockwise.
- Dismantle the motor coupling part by unscrewing the 4 slotted cheese head screws and unscrew the pillars (C). Remove the spring pin (D) from the shaft and remove the upper lipseal (E). Remove the top-plate (F).
- Pull the stirrer shaft and the inner-magnets out of the housing.
- Clean all parts with tissue paper, lubricate the ball bearings (G) with the special grease (art. no. V3LA120031).
- Remove the stirrer shaft from the rotor section; clean and lubricate the surface of the ball bearing (G).
- Replace any O-ring or lipseal if necessary and reassemble the stirrer assembly carefully.

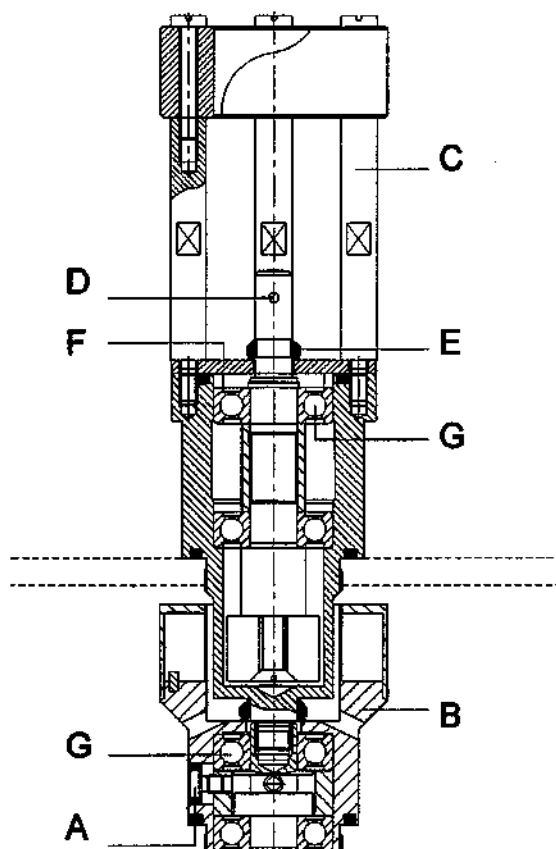

CHAPTER 5

AUXILIARIES

In this chapter, the head-plate-auxiliaries for the 2 - 7 liter bio-reactors are listed.

5.1 SAMPLING:

Assembly holder 6 mm tube for M18 x 1.5 port:

This device fits into a M18 x 1.5 port and can be used to hold any 6 mm (O.D.) tube. The insertion length of this tube can be varied; additions to or sampling from the culture fluid can take place at any level inside the reactor.

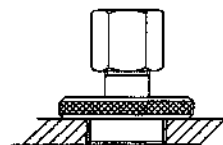

Z811302015

2 - 7 liter reactor, M18 x 1.5 port

Assembly holder 6 mm tube for 10 mm port:

This device can be inserted into a 10 mm port and can be used to hold any 6 mm (O.D.) tube. The insertion length of this tube can be varied; additions to or sampling from the culture fluid can take place at any level inside the reactor.

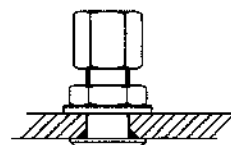

Z81320AH00

2 - 7 liter reactor, 10 mm port

Sample pipe (fixed length):

This assembly is used to sample the culture fluid.

Tube diameter (O.D.): 6 mm (to fit in a 10 mm port)
9.5 mm (to fit in a 12 mm port)

Insertion length: 213 mm (for 2, 3 and 5 l reactors)
325 mm (for 7 l reactor)

Z81319MB03	2 - 5 liter reactor, 10 mm port
Z81319MB05	2 - 5 liter reactor, 12 mm port
Z81319MB07	7 liter reactor, 10 mm port
Z81319MB08	7 liter reactor, 12 mm port

**Sample pipe (height adjustable):**

The height adjustable sample pipe assembly consists of:

- an assembly holder for 6 mm tubes and
- a O.D. 6 mm sample tube.

Tube diameter (I.D.): 4 mm.

Maximum insertion length: 232 mm (2 - 5 liter reactor)
320 mm (7 liter reactor)

With this device, the culture fluid can be sampled at any desired level.

Z81319MB04	2 - 5 liter reactor, 10 mm port
Z81319MB06	7 liter reactor, 10 mm port



Chemostat tube:

The chemostat tube is used in continuous fermentation. This device is designed to achieve a constant level in the reactor.

Liquid is taken out of the reactor through the height adjustable inner tube.

This inner tube is shielded from the reactor by an outer tube to avoid the influence of foam and surface irregularities on the liquid level.

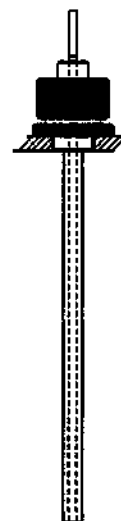

Diameter outer tube: O.D. = 8 mm
I.D. = 6 mm

Diameter inner tube: O.D. = 3.18 mm
I.D. = 1.4 mm

Insertion length: 156 mm (1 - 5 liter reactor)
(outer tube) 306 mm (7 liter reactor)

Z81206CH03 2 - 5 liter reactor, M18 x 1.5 port
Z81206CH07 7 liter reactor, M18 x 1.5 port

Sample pipe (I.D. = 1.56 mm):

This sample pipe is designed for the sampling of small volumes. The internal diameter of the pipe guarantees a minimum dead volume. The sample pipe fits into a 6 mm (baffle) port or into a 10 mm port, depending on type number.



Insertion length: 180 mm

Z81319MB13 2 and 3 liter reactor, 6 mm port
Z81319MB15 2 - 7 liter reactor, 10 mm port

Drain tube:

The drain tube is used to take relatively large samples from the culture and to drain bio-reactor after finishing the process.

Diameter: O.D. = 6.35 mm
I.D. = 4.53 mm

Insertion length: 217 mm

Z81319MB14 2 - 5 liter reactor, 10 mm port

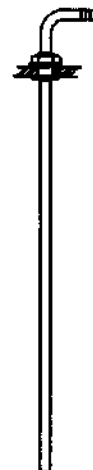
**Sample pipe for screens:**

The sample pipe for screens has a very small dead volume. The height adjustable sample pipe can be used with or without a sample screen.

If it is used without sample screen, the small dead volume of the pipe guarantees samples from the culture that are representative for the reactor contents.

If a sample screen is used at the end of this pipe, cell free samples can be drawn from the culture. Sample screens are available in several pore sizes (see below).

Z81319MB09 2 - 5 liter reactor, 10 mm port
Z81319MB11 7 liter reactor, 10 mm port

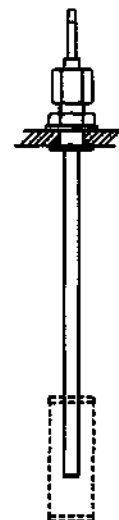
**Sample screen:**

Available pore sizes:

Z811303010 13 μ sample screen
Z811303011 25 μ sample screen
Z811303012 76 μ sample screen
Z811303013 105 μ sample screen

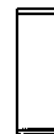

Sample pipe I.D. 10 mm:

This sample pipe is designed for sampling cultures with flocculating organisms (in this case a sample pipe with a small diameter will ruin the flocks and the pipe will be clogged).

The shear forces inside this sample pipe are nearly negligible.

The sample pipe can be fitted in a 12 mm I.D. pH/mV nipple.

Z81319MB22
Z81319MB23

2 - 5 liter reactor, pH/mV nipple
7 liter reactor, pH/mV nipple

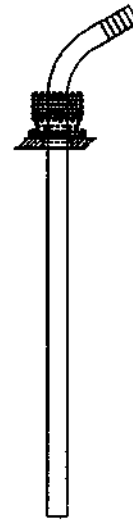

Sample system:

The sample system with a 60 (or 30) ml glass bottle can be mounted onto the head plate of the bio-reactor.

This system, completed with a syringe and connected to the sample pipe (tubing), provides your bio-reactor with an easily operated sampling device.

Z81207SS02

2 - 7 liter reactor

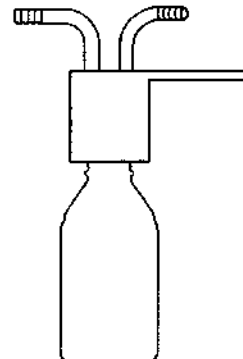

5.2 AERATION:**Air-inlet pipe:**

To meet the oxygen demand of a culture, a sterile gas stream can be sparged through the culture, using an air-inlet pipe.

This pipe can be applied when high gas flow rates are required, since this pipe causes hardly any pressure drop.

The holes in this pipe are located at the bottom to make sure that medium will be driven out by the gas stream.

Insertion length: 236 mm (2 - 5 liter reactor)
 330 mm (7 liter reactor)

Z81318L002	2 liter reactor, 10 mm port
Z81318L003	3 liter reactor, 10 mm port
Z81318L005	5 liter reactor, 10 mm port
Z81318L007	7 liter reactor, 10 mm port

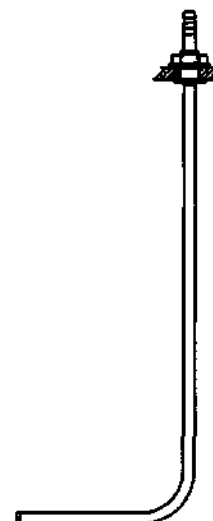
**Air-inlet pipe with porous sparger:**

In cell culture fermentations, high gas flow rates (causing shear forces) might damage the cells.

To be able to meet the oxygen demand of the cells at lower gas flow, the exchange-surface must be increased.

This can be achieved by using this sparge pipe.

The sintered metal tip produces tiny air bubbles for optimum gas distribution.

Insertion length: 238 mm (2 - 5 liter reactor)
 330 mm (7 liter reactor)

Z81318L004	2 liter reactor, 10 mm port
Z811303005	3 liter reactor, 10 mm port
Z81318L006	5 liter reactor, 10 mm port
Z81318L008	7 liter reactor, 10 mm port

Z811303008 Porous sparger for air-inlet pipe

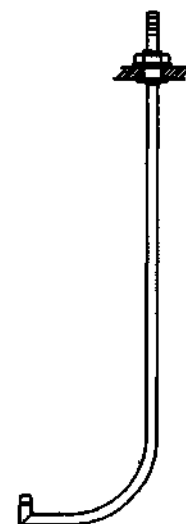

Tuning valve:

The tuning valve can be installed on top of the stainless steel air-outlet condenser in order to create a small over-pressure in the reactor.

This has the following advantages:

- risk of contamination is reduced,
- oxygen transfer to the medium is increased,
- sampling the culture is eased.

For safety reasons it is strongly advised to use this tuning valve in combination with the pressure relief valve (listed below).

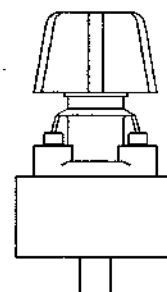

Z811302020 1 - 7 liter reactor

Pressure relief valve:

When over-pressure is applied in the (glass) Applikon 1 - 7 liter bio-reactors, it is advised to install this relief valve.

The pressure at which the relief valve will open can be adjusted manually.

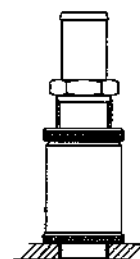

Z811302050 1 - 7 liter reactor, M18 x 1.5 port

Air-outlet pipe:

The air-outlet pipe can be used for either gas outlet or gas overlay. The latter use is for head space aeration (separate from or in combination with sparging gas through the culture).

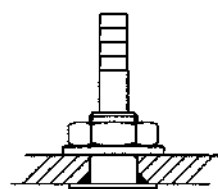

Z81308LU02 2 - 7 liter reactor, 10 mm port

Air-outlet condenser:

Working at elevated temperature and using aeration of the culture might cause too much evaporation during fermentation (increase of nutrient concentration and decrease in volume); this can be prevented by using an air-outlet condenser.

Available condensers:

- glass condenser, fits into the pH/mV nipple.
- stainl. steel condenser, fits into the M18 x 1.5 port

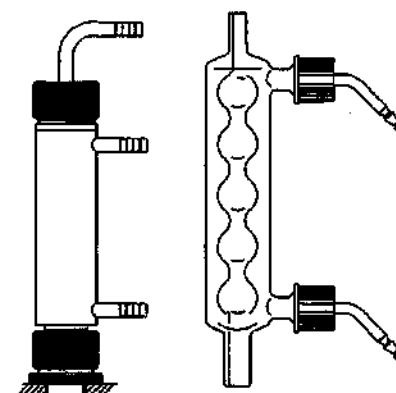

Z81309L003

glass condenser for 2 - 5 liter reactor, pH/mV nipple

Z81309L002

SS condenser for 2 - 5 liter reactor, M18 x 1.5 port

✱ Z81309L007

SS condenser for 7 liter reactor, M18 x 1.5 port ✱

5.3 ADDITION:

Septum holder:

The septum holder is equipped with a silicone rubber septum and can be used as a universal addition port by piercing it with one or more needles.

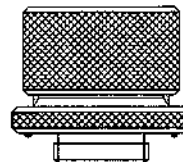

Z81302PD02

2 - 7 liter reactor, M18 x 1.5 port

Needle for septum:

The needle is used to pierce the septum and to add a fluid or gas to the culture.



Z81309IN02

Addition pipe 10 mm port:

This addition pipe can be used to add fluids or gasses to the reactor.

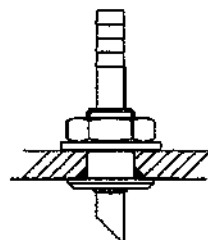

Z81324MT02

2 - 7 liter reactor, 10 mm port

Medium inlet triple:

The medium inlet triple allows you to equip one M18 x 1.5 port with three addition ports (e.g. for acid, alkali and anti-foam addition). This device can be used to expand the number of entries beyond the number of ports in the head plate.

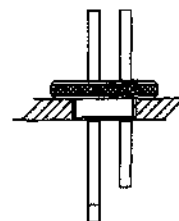

Z81324MT03

2 - 7 liter reactor, M18 x 1.5 port

Liquid entry system:

When running a continuous culture, backgrowth of organisms into the medium container must be prevented.

The liquid entry system uses a sterile gas flow to transfer the fresh medium to the reactor; in this way, direct contact between the culture and the medium storage container does not exist.

The liquid entry system fits into the pH/mV nipple (Z81300N002).

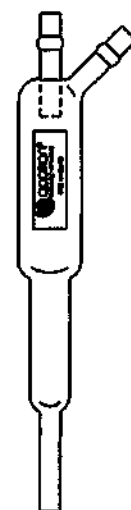

Z81309IN03

2 - 7 liter reactor, pH/mV nipple

Liquid addition bottle:

The liquid addition bottles are available in the following sizes:

0.5 liter	Z811302009
1.0 liter	Z811302010
2.0 liter	Z811302011
5.0 liter	Z811302012
10 liter	Z811302013
20 liter	Z811302014

The liquid addition bottle comes with an air-inlet filter.



5.4 MIXING:

Two types of stirrer assemblies are available for insertion in the central M30 x 1 port of the head plate:

1. The lipseal stirrer assembly:

Material: Stainless Steel

Diameter shaft: 8 mm

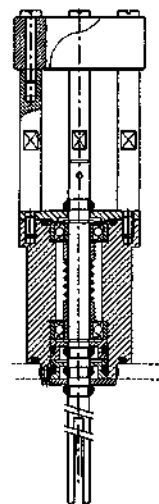

Z81315R003 2 - 5 liter reactor, M30 x 1 port
Z81315R007 7 liter reactor, M30 x 1 port

2. The magnetically coupled stirrer assembly:

Material: Stainless Steel

Diameter shaft: 8 mm

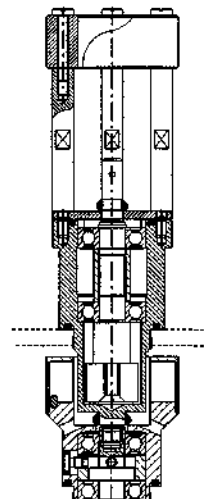

Z81315MG03 2 - 5 liter reactor, M30 x 1 port
Z81315MG07 7 liter reactor, M30 x 1 port

Baffle assembly:

Baffles are used to increase the mixing efficiency (without baffles, the medium flow can become laminar, causing poor mixing efficiency and mass transfer). The baffles are mounted near the reactor wall for optimum mixing performance. The baffle assembly consists of one baffle and mounting material. Normally three baffles are used to create maximum mixing efficiency.

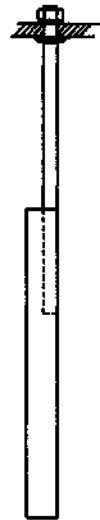

Insertion length: 220 mm (for 2 and 3 liter reactor)
 223 mm (for 5 liter reactor)
 317 mm (for 7 liter reactor)

Z81326KS03 2 and 3 liter reactor, 6 mm port
 Z81326KS05 5 liter reactor, 10 mm port
 Z81326KS07 7 liter reactor, 10 mm port

Draught tube:

The draught tube is used to obtain maximum mixing efficiency and optimum oxygen mass transfer by enforcing an axial flow pattern in the reactor. The draught tube must be used in combination with a marine impeller (the vortex type for foam killing, the scoping type in case a vortex or gas bubbles in the culture liquid are not allowed).

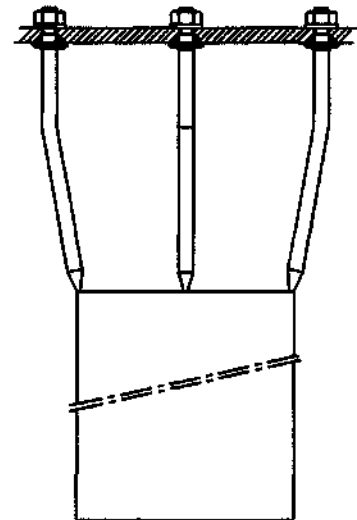

Insertion length: 220 mm (3 liter reactor)
 Tube length: 120 mm

Draught tubes for other reactors: on request.

Z81334DT03 3 liter reactor, 3 x 6 mm port

Impellers:

The following impellers are available for the Applikon stirrer assemblies (lipseal and magnetically coupled):

- Z81312RS02 Rushton impeller, 4 bladed, 2 - 3 liter reactor
- Z81313R602 Rushton impeller, 6 bladed, 2 - 3 liter reactor
- Z81313R645 Rushton impeller, 6 bladed (vortex), 2 - 3 liter reactor
- Z81313R607 Rushton impeller, 6 bladed, 5 and 7 liter reactor

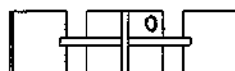

- Z81314RC02 Marine impeller (vortex), 2 - 3 liter reactor
- Z81314RC03 Marine impeller (scoping), 2 - 3 liter reactor
- Z81314RC07 Marine impeller (vortex), 5 and 7 liter reactor
- Z81314RC08 Marine impeller (scoping), 5 and 7 liter reactor

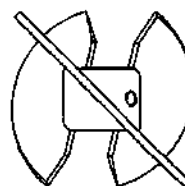

5.5 HEAT EXCHANGERS:

Two different types of heat exchangers are available.

1: fitting into a M18 x 1.5 port. This heat exchanger can be used in the 2 - 5 liter reactors.

Insertion length: 226 mm

Z81317KV03 2 - 5 liter reactor, M18 x 1.5 port



2: fitting two 10 mm ports. This type of heat exchanger is available for the 5 and 7 liter reactor.

Insertion length: 210 mm (5 liter reactor)
 315 mm (7 liter reactor)

Z81317HE05 5 liter reactor, two 10 mm ports
 Z81317HE07 7 liter reactor, two 10 mm ports

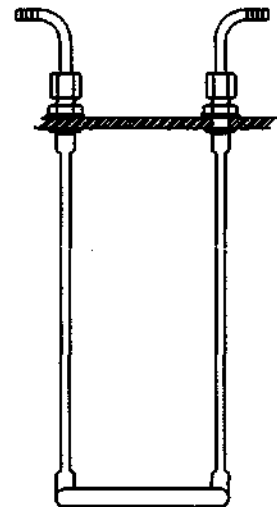

5.6 SENSOR HOLDERS:**pH/mV nipple:**

This nipple fits into a M18 x 1.5 port and can accommodate a pH or mV electrode, a liquid entry system, the glass condenser or other 12 mm (O.D.) tubes.

All items that are hold by this nipple are height-adjustable.

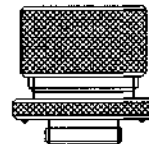

Z81300N002

2 - 7 liter reactor, M18 x 1.5 port

Thermometer pocket:

Temperature measurement (and control) is very important in bio-technology. The thermometer pocket allows you to insert a temperature probe (Pt100 or mercury thermometer) in the reactor.

Fill the thermometer pocket with water or silicone oil in order to improve thermal contact between the culture and the probe.

Insertion length: 200 mm (2 - 5 liter reactor)
 300 mm (7 liter reactor)

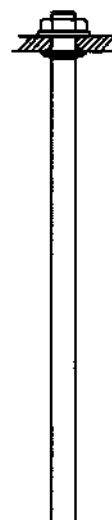

Z81323TP03

2 - 5 liter reactor, 10 mm port

Z81323TP07

7 liter reactor, 10 mm port

DO₂ electrode holder:

Every Applikon 2 - 7 liter head plate is equipped with a G3/4" port for the DO₂ electrode holder. The electrode is height-adjustable.



Z811303001

2 - 7 liter reactor, G3/4" port

Nipple ID = 12 mm for G3/4" port:

This nipple can be used to fit a pH or mV electrode or any other device with an OD of 12 mm (height adjustable).

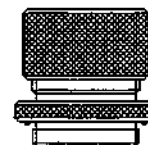

Z81300N005 1 - 7 liter reactor, G3/4" port

Available sensors:

Z71201AP10	Sensor pH, L = 235 mm for 2 - 5 liter reactor
Z71201AP20	Sensor pH, L = 385 mm for 7 liter reactor
Z71201AG10	Sensor pH gel, L = 235 mm for 2 - 5 liter reactor
Z71201AG20	Sensor pH gel, L = 385 mm for 7 liter reactor
Z71202AP10	Sensor DO ₂ , L = 215 mm for 2 - 5 liter reactor
Z71202AP20	Sensor DO ₂ , L = 215 mm for 7 liter reactor
Z71203MV02	Sensor redox, L = 320 mm
Z71204T002	Sensor temperature, L = 200 mm
Z71205AF03	Sensor foam for 2 - 7 liter reactor
Z711203001	Level detector for 2 - 7 liter reactor

5.7 BLIND STOPPERS:

Blind stopper 6, 10 and 12 mm ports:

These blind stoppers can be used to blind unused ports in the head plate; the assemblies are fitted into the head plate from the inside of the reactor, leaving only a flat surface in the reactor.



Z81321BP03	2 and 3 liter reactor, 6 mm port
Z81322BP03	2 - 7 liter reactor, 10 mm port
Z81322BP08	2 - 7 liter reactor, 12 mm port

Blind stopper threaded ports:

The following blind stoppers are available for the threaded ports:

Z81301BD04	2 - 7 liter reactor, G3/4" port
Z81301BD03	2 - 7 liter reactor, M30 x 1 port
Z81301BD02	2 - 7 liter reactor, M18 x 1.5 port

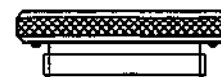

CHAPTER 6

DRAWINGS

The following drawings are enclosed:

D3002-1b.12.006	Bioreactor 2l dished H/D = 1.5
D3002-1 .12.013	Bioreactor 2l jacketed H/D = 1.5
D3003-1 .12.018	Bioreactor 3l flat bottom
D3003-1 .12.017	Bioreactor 3l dished bottom
D3003-1 .12.019	Bioreactor 3l jacketed
D3005-1a.12.001	Bioreactor 5l dished bottom
D3005-1a.12.007	Bioreactor 5l jacketed
D3007-1a.12.014	Bioreactor 7l dished bottom
D3007-1a.12.015	Bioreactor 7l jacketed
D3002-1a.06.005	Stirrer assembly lipseal 2 - 5 liter
D3007-1a.06.004	Stirrer assembly lipseal 7 liter
D3002-1 .06.006	Stirrer ass. magn. coupled 2 - 5 liter
D3007-1 .06.003	Stirrer ass. magn. coupled 7 liter

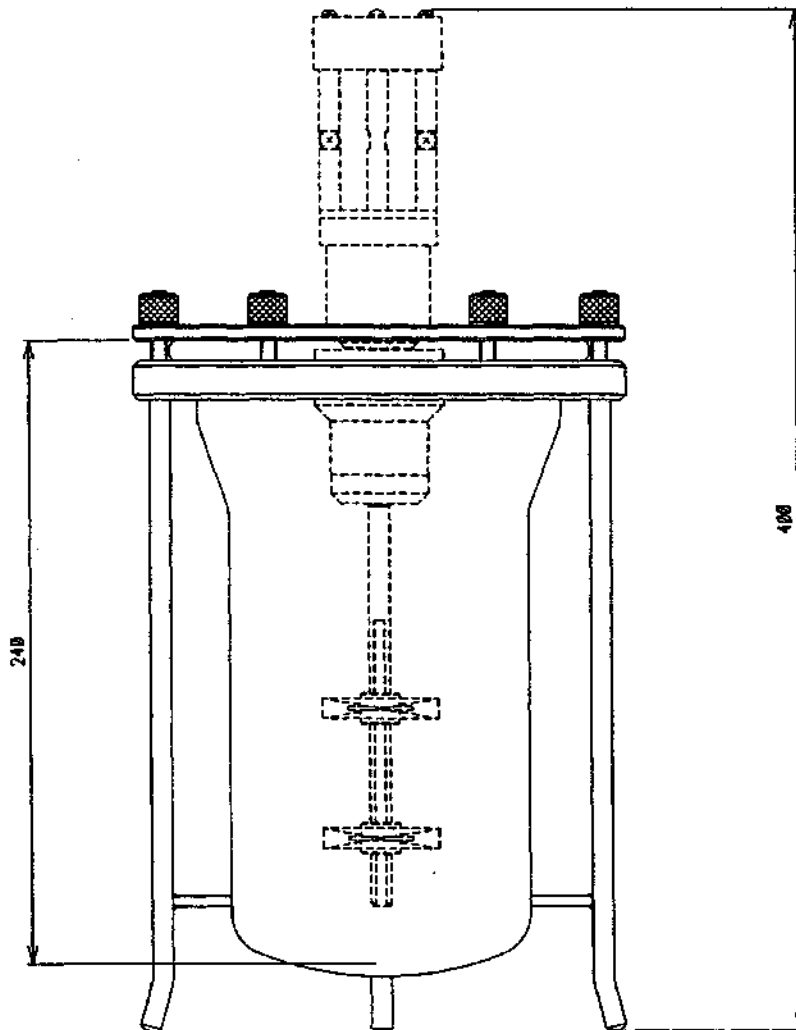
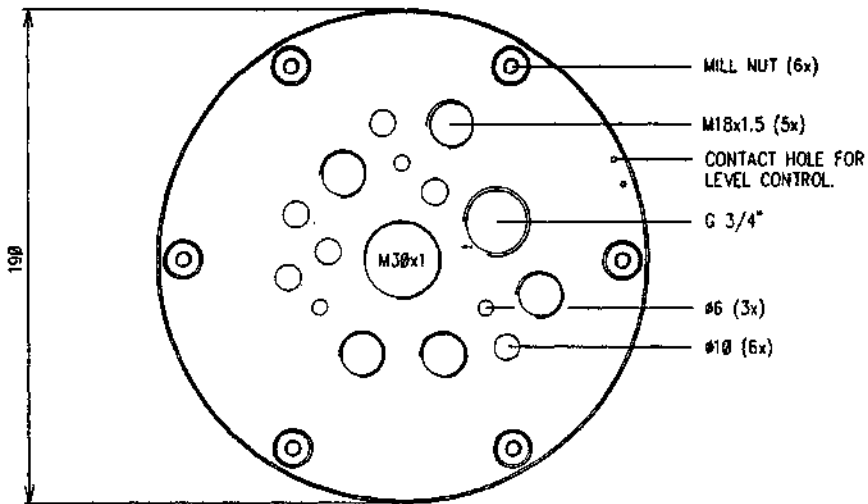

POS.	QTY.	DESCRIPTION	MATERIAL OR TYPE	REMARKS
BIOREACTOR BASIC 2L DISHED H/D=1.5				PROJ. CHECKED: <i>258</i>
aplikon DEPENDABLE INSTRUMENTS			PART NO.: 2611020002 SCALE: DESIGN: PV DATE: 26-09-90 MOD.: 613 03 91	DRAWING NO.: D3002-1b.12.006 SHEET: 1 OF 1 DIMENSIONS IN mm FORM: A3
<small>© 1998 Applikon Dependable Instruments B.V. No part of this drawing may be copied or reproduced in any form or by any means or transferred to any third party without the prior written consent of Applikon Dependable Instruments B.V.</small>				
<small>APPLIKON DEPENDABLE INSTRUMENTS BV SCHEDAM-HOLLAND P.O.B. 48 010 - 462 18 55 010 - 437 96 48</small>				

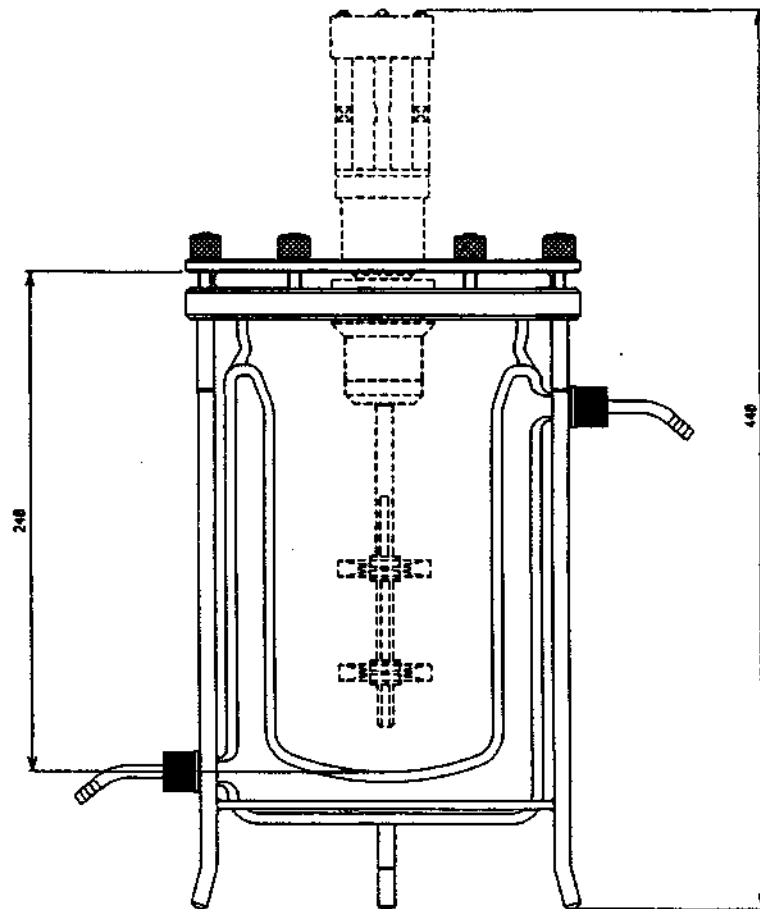
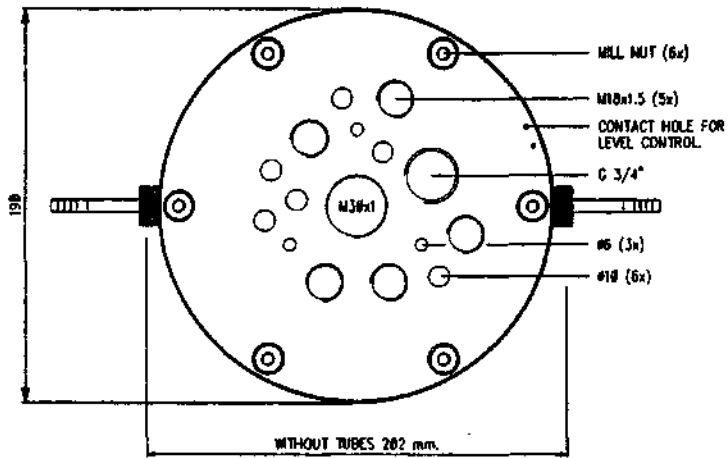

POS.	QTY.	DESCRIPTION	MATERIAL OR TYPE	REMARKS
BIOREACTOR 2L JACKETED HD=1.5				PROJ. CHECKED: <i>Vmes</i>
		PART NO.: 761104CT04 SCALE: : DESIGN.: PV DATE: 01-10-91 MOD.:	DRAWING NO.: D3002-1 .12.013 SHEET: 1 OF 1 DIMENSIONS #1 mm FORM: A3	
<small>© 1991 Applikon Dependable Instruments B.V. No part of this drawing may be copied or reproduced in any form or by any means or transferred to any third party without the prior written consent of Applikon Dependable Instruments B.V.</small>				
<small>APPLIKON DEPENDABLE INSTRUMENTS BV SCHEDAM-HOLLAND P.O.B 149 D10 - 462 18 55 FAX 010 - 437 96 48</small>				

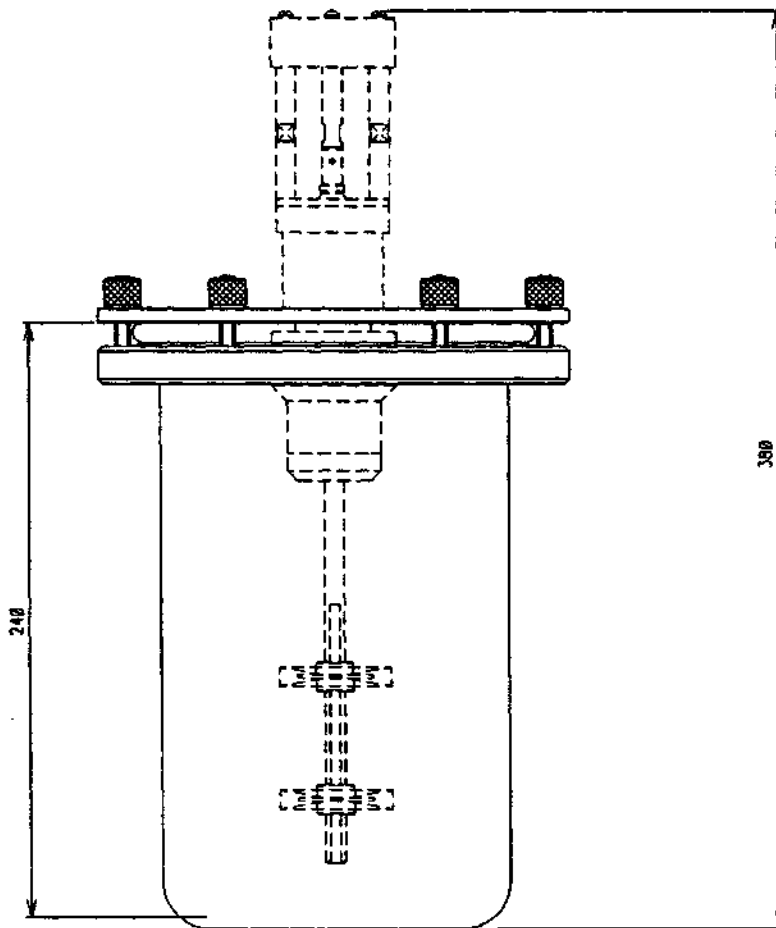
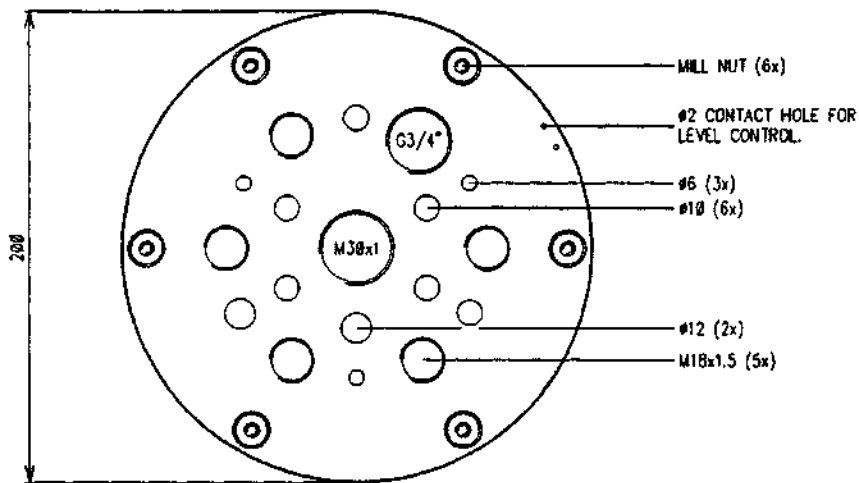

POS.	QTY.	DESCRIPTION	MATERIAL OR TYPE	REMARKS
BIOREACTOR 3 L FLAT BOTTOM				PROJ. CHECKED: <i>Vms</i>
aplikon DEPENDABLE INSTRUMENTS		PART NO.: 7611000004 SCALE: : DESIGN.: PV DATE: 26-09-91 MOD.:	DRAWING NO.: D3003-1.12.018 SHEET: 1 OF 1 DIMENSIONS IN mm FORM: A3	
<small>© 1991 Applikon Dependable Instruments B.V. No part of this drawing may be copied or reproduced in any form or by any means or transferred to any third party without the prior written consent of Applikon Dependable Instruments B.V.</small>				
<small>APPLIKON DEPENDABLE INSTRUMENTS BV SCHEDAM-HOLLAND P.O.B. 149 010-4821855 FAX 010-4379648</small>				

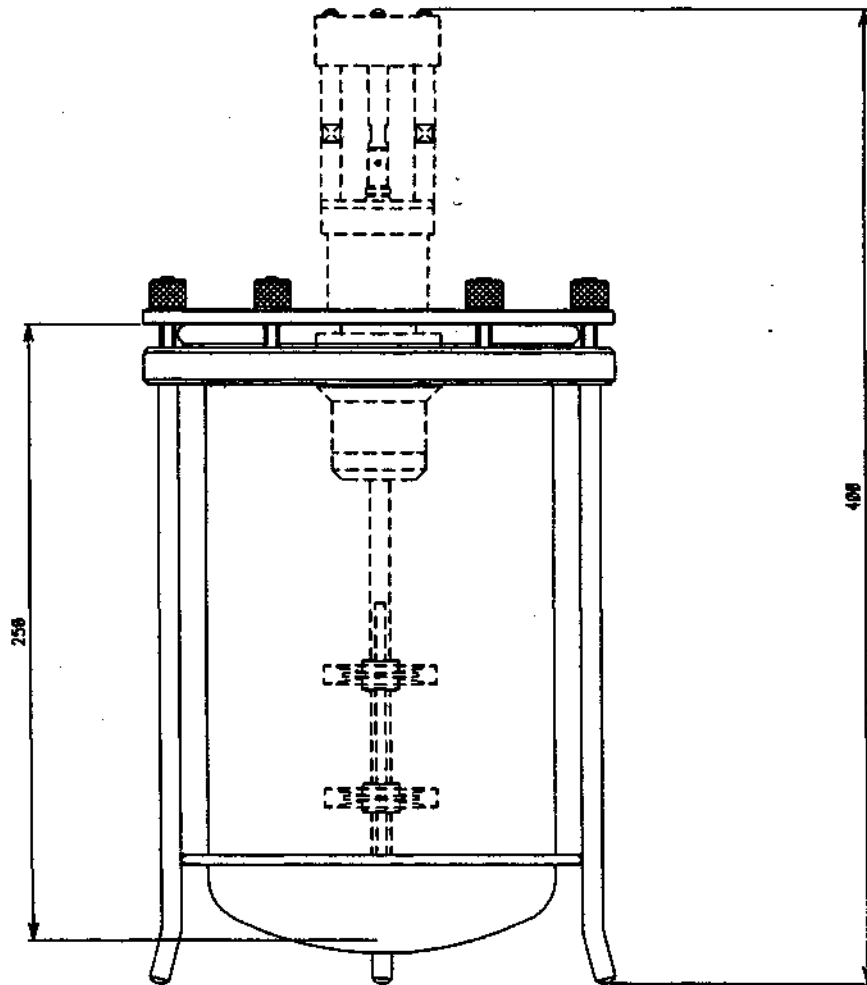
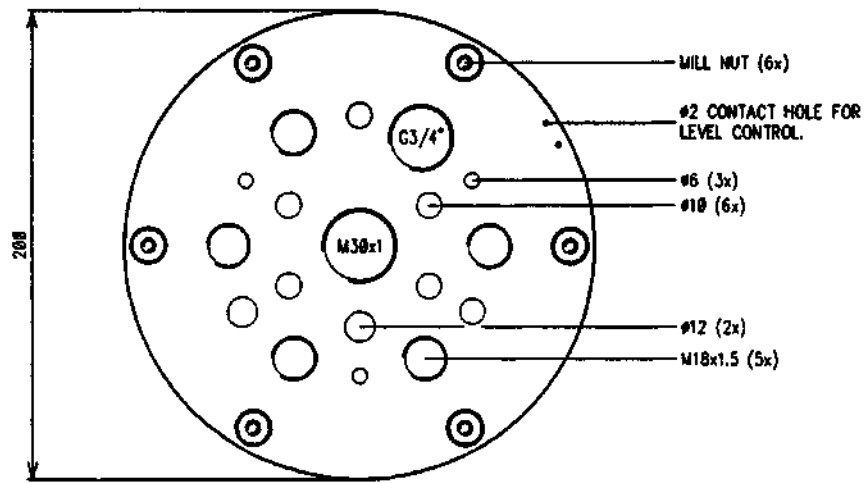

POS.	QTY.	DESCRIPTION	MATERIAL OR TYPE	REMARKS
BIOREACTOR 3 L DISHED BOTTOM				PROJ. CHECKED: <i>Jms</i>
 applikon [®] DEPENDABLE INSTRUMENTS		PART NO.:	Z61101C006	DRAWING NO.:
		SCALE:		D3003-1 .12.017
		DESIGN:	PV	SHEET: 1 OF 1
		DATE:	26-09-91	DIMENSIONS IN mm FORM: A3
MOD.:				
<small>© 1991 Applikon Dependable Instruments B.V. No part of this drawing may be copied or reproduced in any form or by any means or transferred to any third party without the prior written consent of Applikon Dependable Instruments B.V.</small>				
<small>APPLIKON DEPENDABLE INSTRUMENTS BV SCHEDAM-HOLLAND ☐ P.O.B. 149 ☉ 010 - 402 14 95 FAX 010 - 437 86 48</small>				

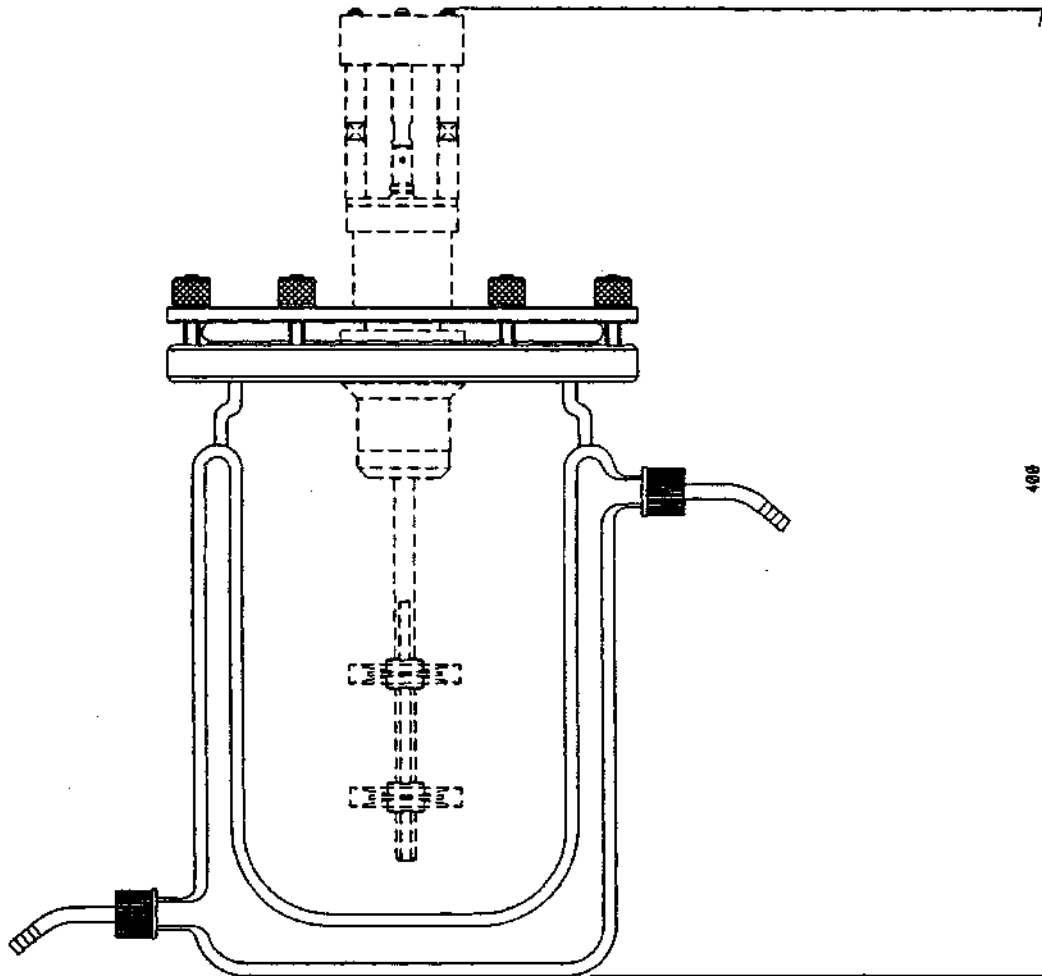
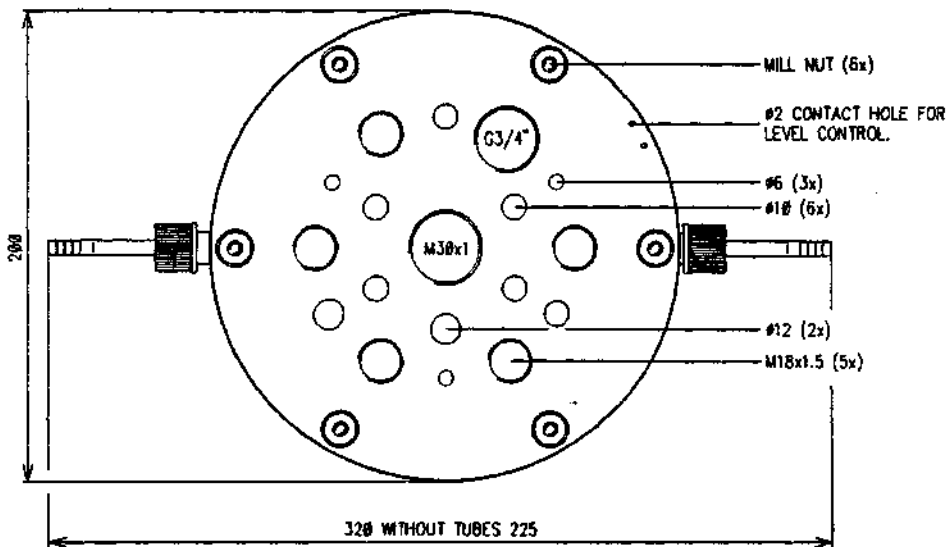

POS.	QTY.	DESCRIPTION	MATERIAL OR TYPE	REMARKS
BIOREACTOR 3 L JACKETED				PROJ. CHECKED: <i>Vms</i>
aplikon DEPENDABLE INSTRUMENTS		PART NO.: 261103CT04 SCALE : DESIGN : PV DATE : 26-09-91 MOD :	DRAWING NO.: D3003-1 .12.019 SHEET : 1 OF 1 DIMENSIONS IN mm FORM: A3	
<small>© 1991 Applikon Dependable Instruments B.V. No part of this drawing may be copied or reproduced in any form or by any means or transferred to any third party without the prior written consent of Applikon Dependable Instruments B.V.</small>				
<small>APPLIKON DEPENDABLE INSTRUMENTS BV SCHEDAM-HOLLAND P.O.B. 149 010-4621855 FAX 010-4379848</small>				

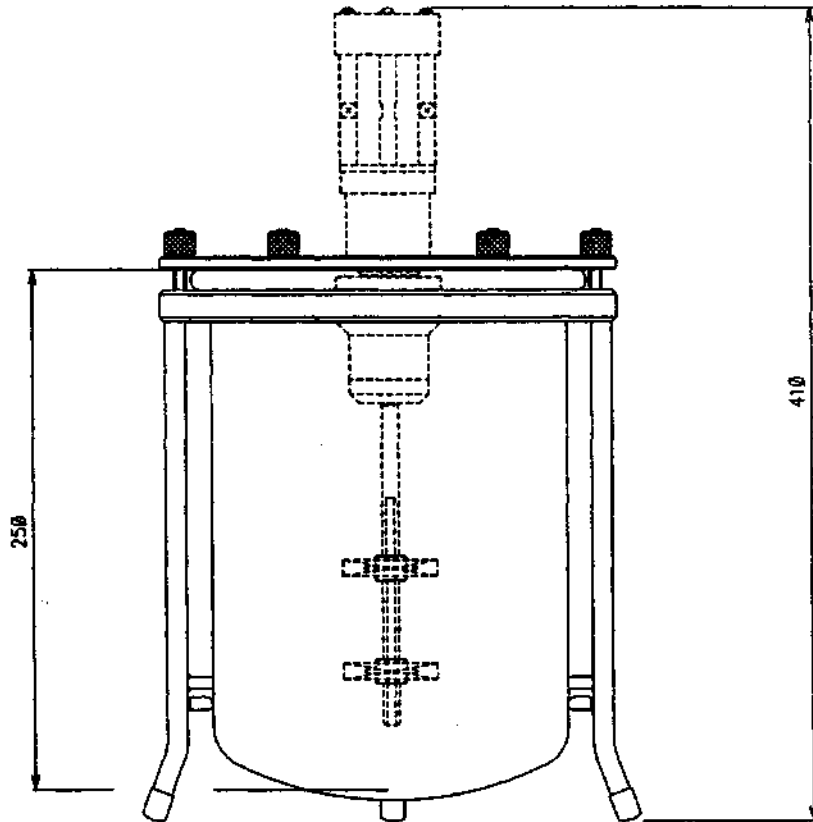
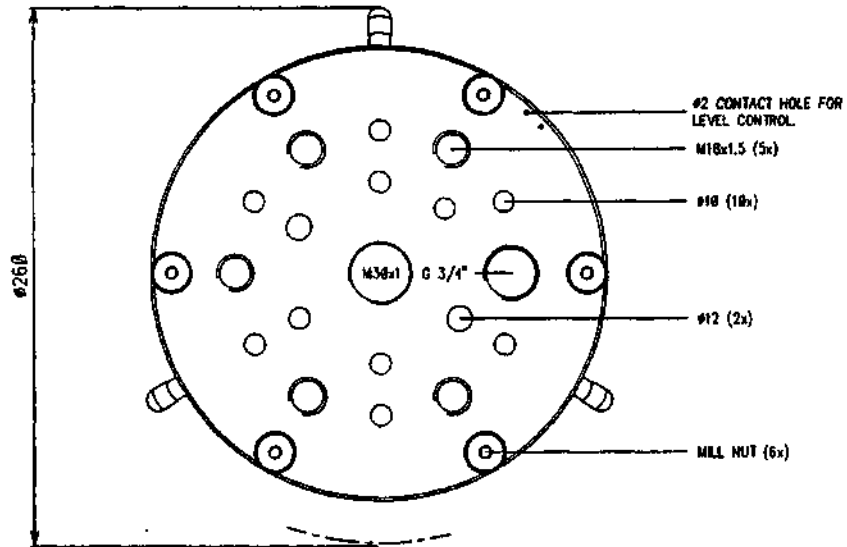

POS.	QTY.	DESCRIPTION	MATERIAL OR TYPE	REMARKS
BIOREACTOR 5L DISHED BOTTOM				PROJ. CHECKED: Vms DRAWING NO.: D3005-1a.12.001
 applikon® DEPENDABLE INSTRUMENTS		PART NO.:	Z611000005	SHEET : 1 OF 1 DIMENSIONS IN mm FORM: A3
		SCALE :		
		DESIGN :	PV	
		DATE :	24-07-90	
		MOD :	0108 10 91	
© 1991 Applikon Dependable Instruments B.V. No part of this drawing may be copied or reproduced in any form or by any means or transferred to any third party without the prior written consent of Applikon Dependable Instruments B.V.				
APPLIKON DEPENDABLE INSTRUMENTS BV SCHEDAM-HOLLAND P.O.B. 149 010 - 482 8555 FAX 010 - 437 9846				

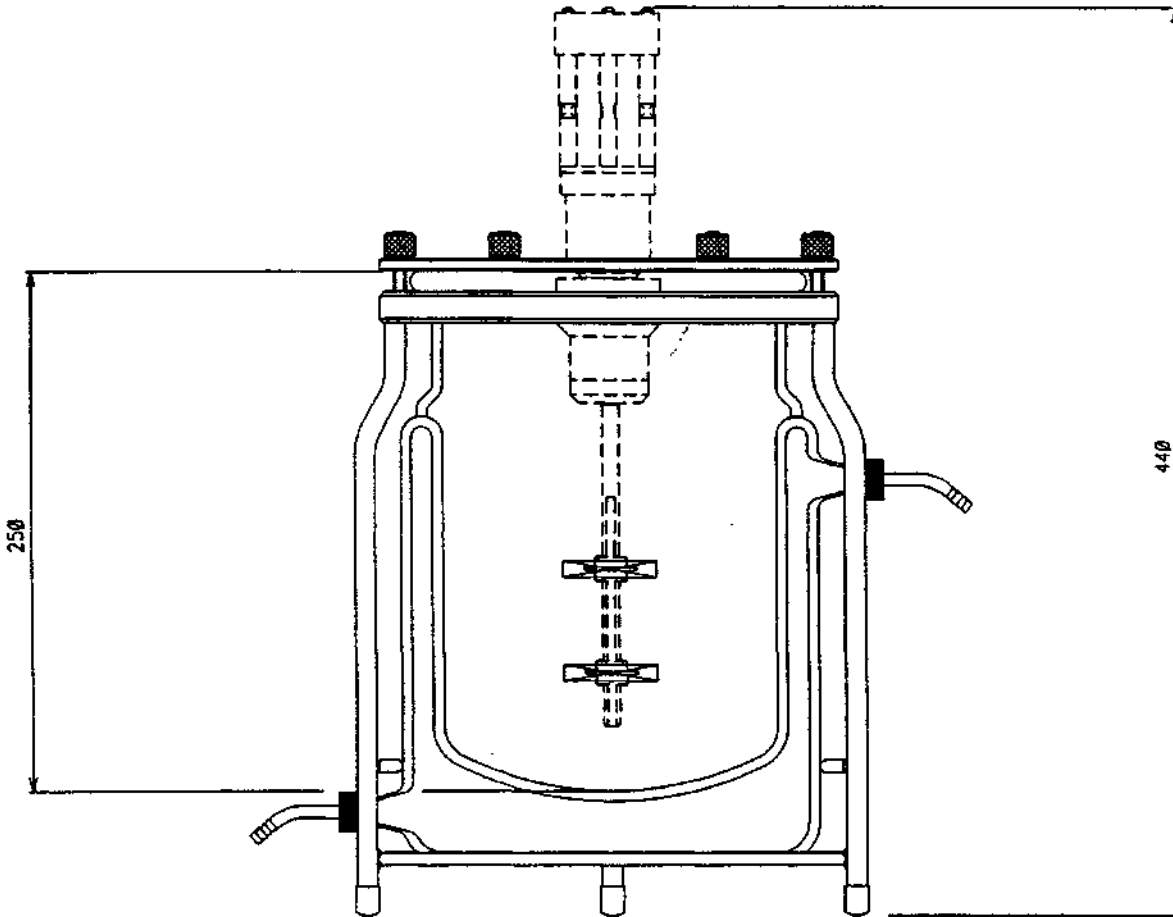
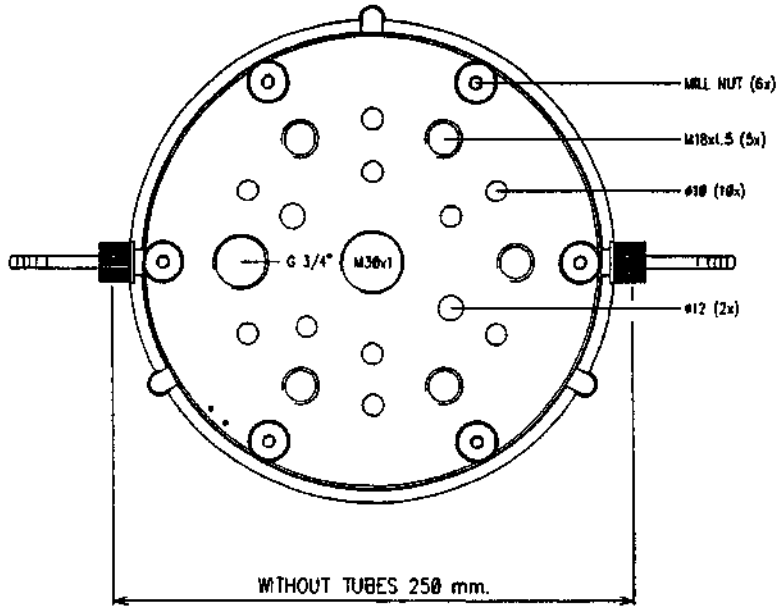

POS.	QTY.	DESCRIPTION	MATERIAL OR TYPE	REMARKS
BIOREACTOR 5L JACKETED				PROJ. CHECKED: <i>V. M. G.</i>
 applikon [®] DEPENDABLE INSTRUMENTS		PART NO. :	761104CT05	DRAWING NO. :
		SCALE :		D3005-1a.12.007
		DESIGN :	PV	SHEET : 1 OF 1
		DATE :	04-10-91	DIMENSIONS IN mm FORM: A3
MOD. :	05 11 91			

© 1991 Applikon Dependable Instruments B.V.
 No part of this drawing may be copied or reproduced in any form or by any means or transferred to any third party without the prior written consent of Applikon Dependable Instruments B.V.

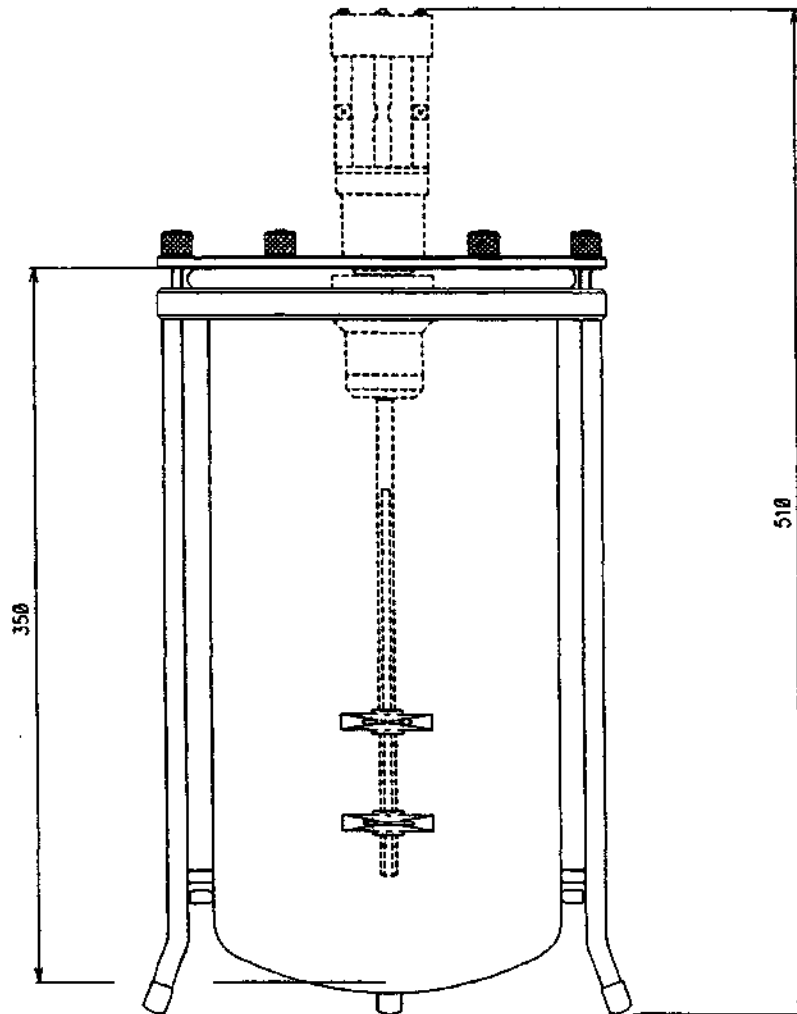
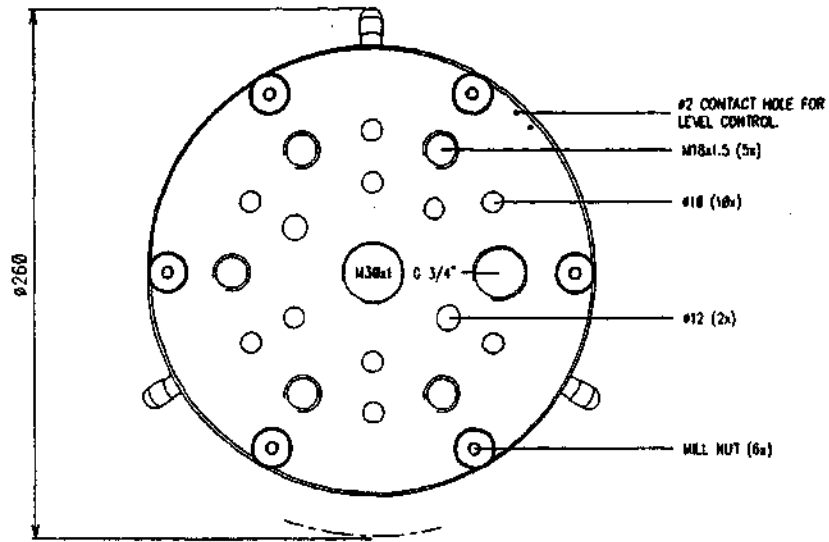

POS.	QTY.	DESCRIPTION	MATERIAL OR TYPE	REMARKS
BIOREACTOR BASIC 7L. DISHED BOTTOM				PROJ. CHECKED: <i>Rbl</i>
		PART NO.: 7611000007 SCALE: DESIGN: PV DATE: 24-07-90 MOD: 020 03 91	DRAWING NO.: D3007-1a.12.014 SHEET: 1 OF 1 DIMENSIONS IN mm FORM: A3	
<small>© 1990 Applikon Dependable Instruments B.V. No part of this drawing may be copied or reproduced in any form or by any means or transferred to any third party without the prior written consent of Applikon Dependable Instruments B.V.</small>				
APPLIKON DEPENDABLE INSTRUMENTS BV SCHEDAM-HKJ AND P.O.B. 149 4009 ORO 482 1855 FAX 010 - 437 96 41				

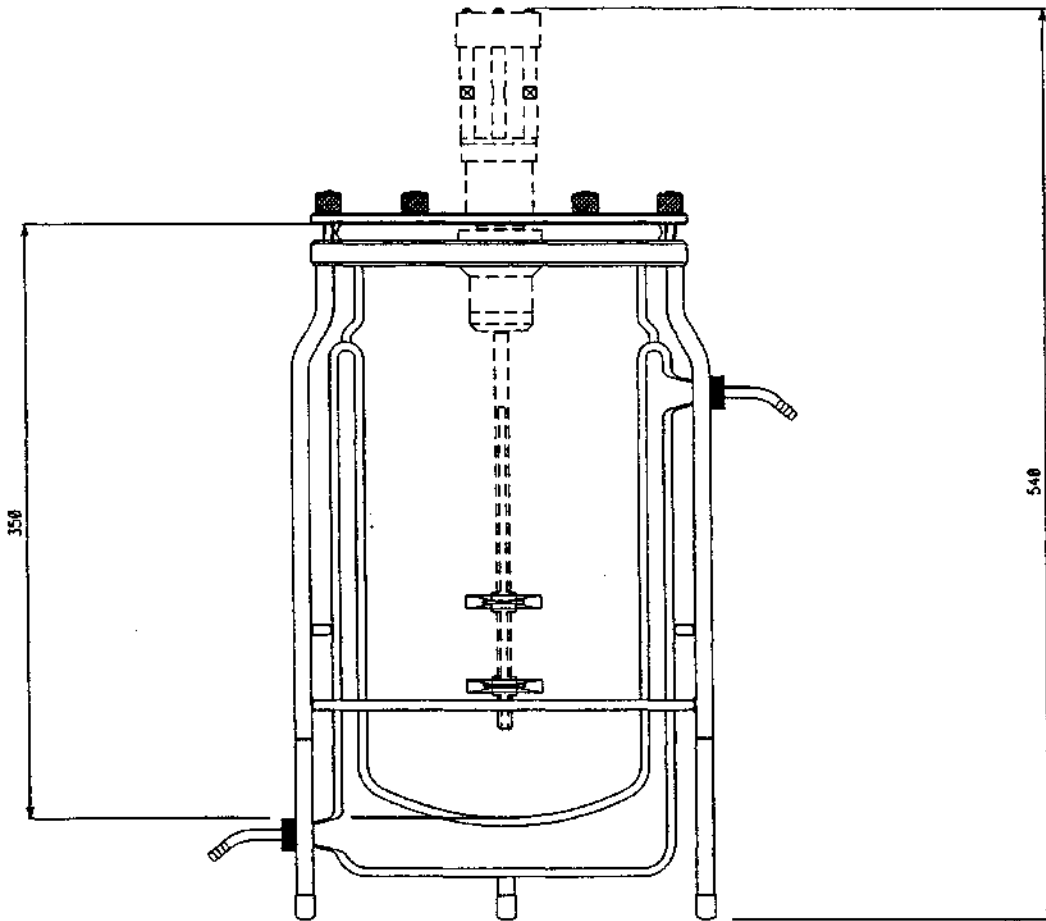
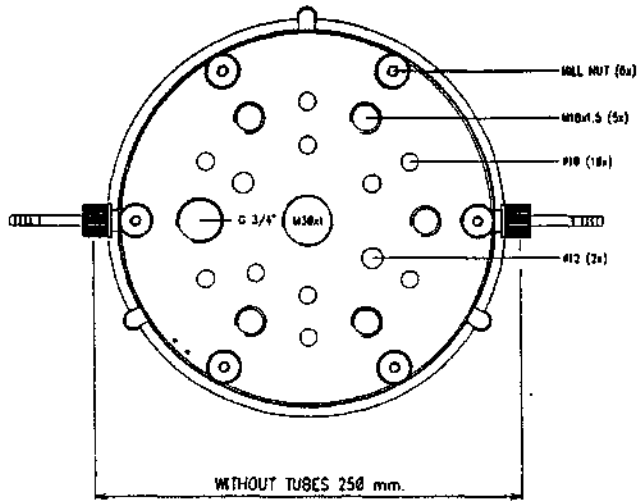

POS.	QTY.	DESCRIPTION	MATERIAL OR TYPE	REMARKS
BIOREACTOR 7L JACKETED				PROJ. CHECKED:
		PART NO.: Z61103CT07		DRAWING NO.: D3007-1a.12.015
		SCALE:	DESIGN.: PV	SHEET: 1 OF 1
		DATE: 04-10-91	MOD.: 0105 11 91	DIMENSIONS IN mm FORM: A3
<small>© 1991 Applikon Dependable Instruments B.V. No part of this drawing may be copied or reproduced in any form or by any means or transferred to any third party without the prior written consent of Applikon Dependable Instruments B.V.</small>				
<small>APPLIKON DEPENDABLE INSTRUMENTS BV SCHIEDAM-HOLLAND ☒ P.O. 149 ☉ 010 - 462 1855 FAX 010 - 437 9648</small>				

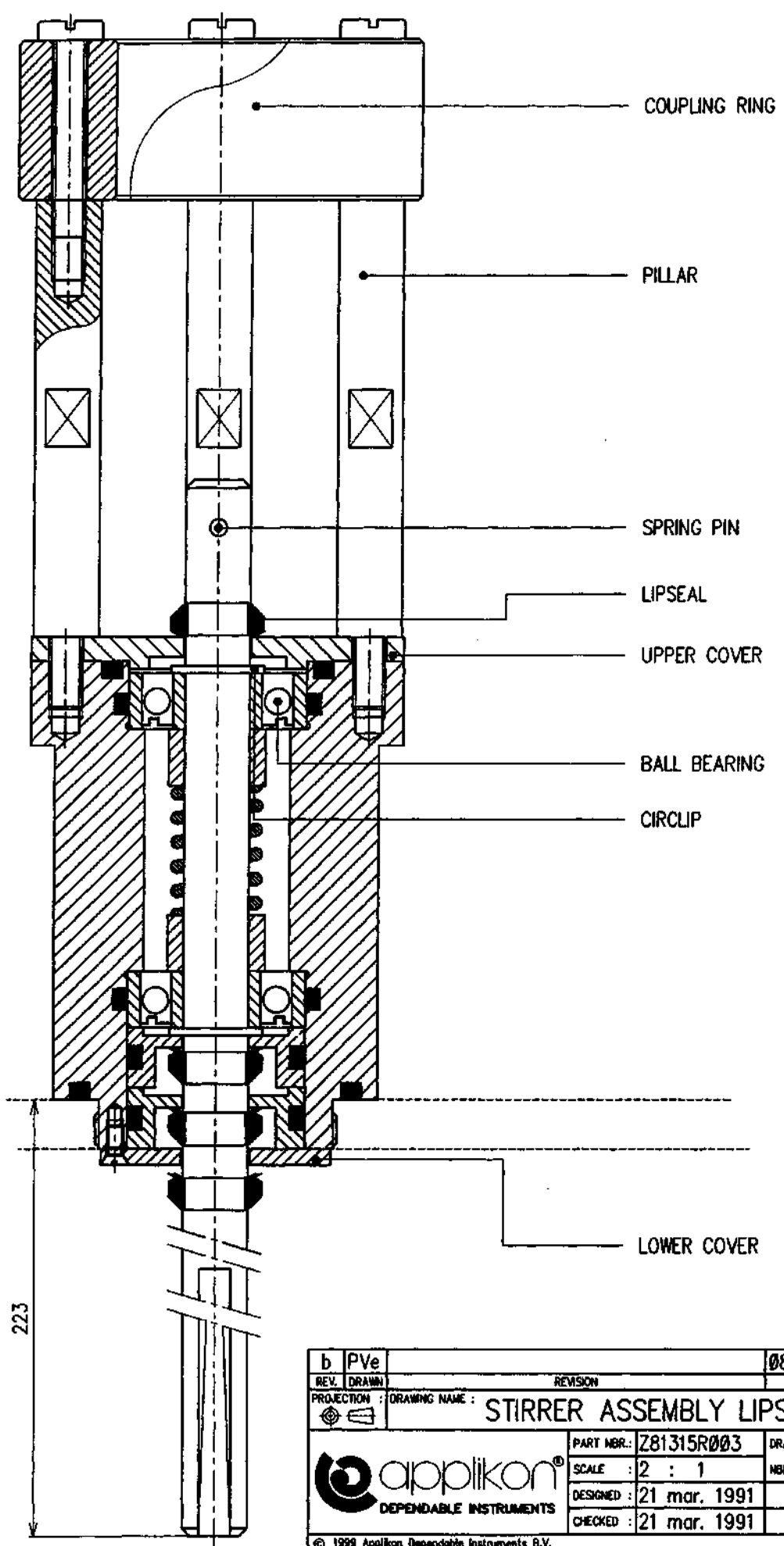

b	PVe	08 nov. 1995	08 nov.95 MVo
REV. DRAWN	REVISION	REVISION DATE	CHECKED
PROJECTION : DRAWING NAME : STIRRER ASSEMBLY LIPSEAL 2-5L.			
 applikon DEPENDABLE INSTRUMENTS		PART NBR.: Z81315R003	DRAWING NBR.: D3002-1b.06.005
SCALE : 2 : 1		DESIGNED : 21 mar. 1991	PVe
CHECKED : 21 mar. 1991		JHe	APPR.: SHEET: 1 of 1
<small>© 1999 Applikon Dependable Instruments B.V. No part of this drawing may be copied or reproduced in any form or by any means or transferred to any third party without the prior written consent of Applikon Dependable Instruments B.V.</small>			DIMENSIONS ARE IN mm
<small>A.D.I. B.V. P.O. BOX 149 3100 AC SCHEDAM HOLLAND (31)10-2983555 FAX (31)10-4379648</small>			SIZE : A3

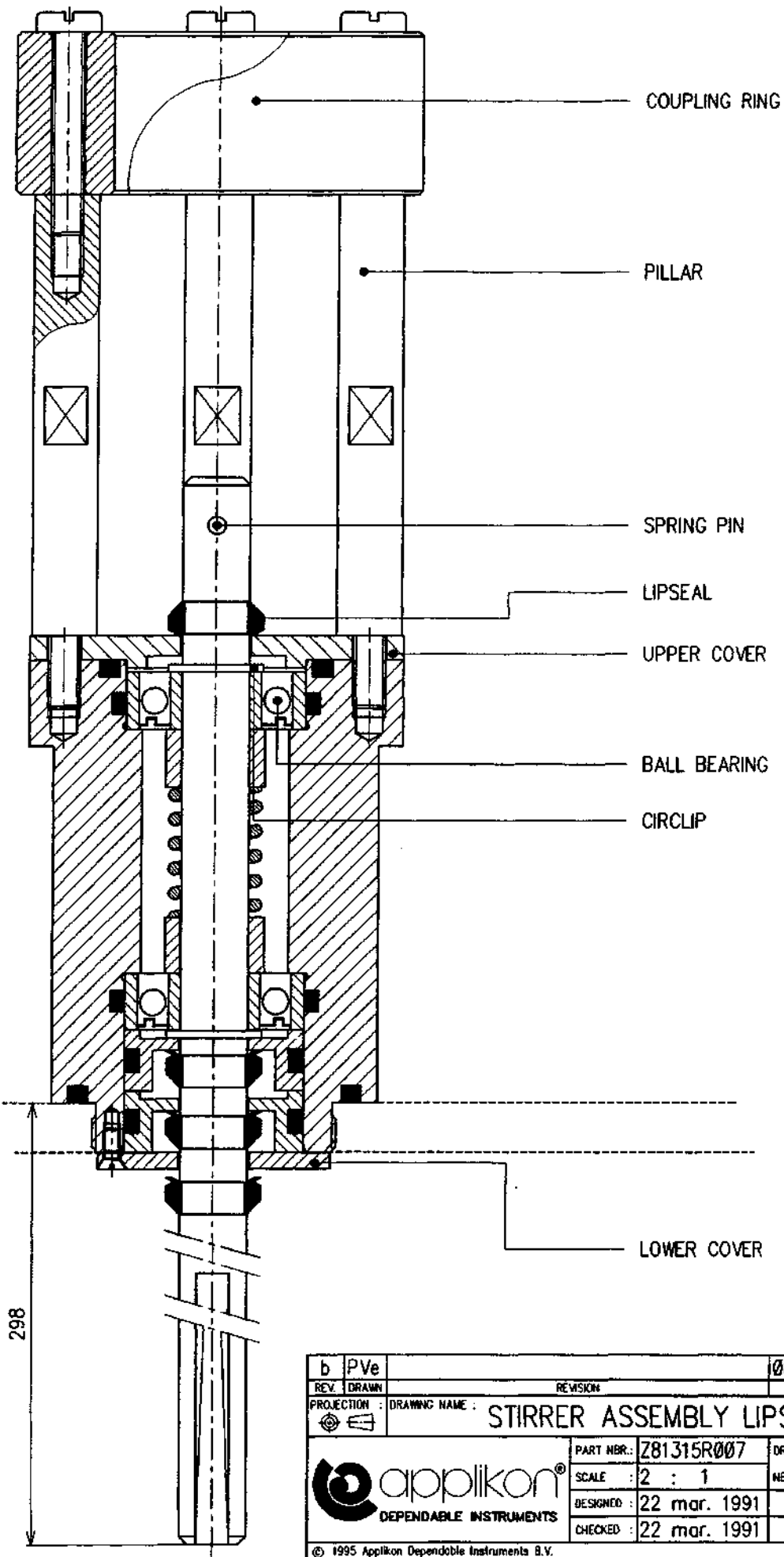

b	PVe	08 nov. 1995	08 nov.95	MVo
REV	DRAWN	REVISION	REVISION DATE	CHECKED
PROJECTION	DRAWING NAME : STIRRER ASSEMBLY LIPSEAL 7L.			
 applikon DEPENDABLE INSTRUMENTS		PART NBR. : Z81315R007	DRAWING NBR. : D3007-1b.06.004	
		SCALE : 2 : 1	DESIGNED : 22 mar. 1991	PVe
		CHECKED : 22 mar. 1991	JHe	APPR. : MVo
		© 1995 Applikon Dependable Instruments B.V. No part of this drawing may be copied or reproduced in any form or by any means or transferred to any third party without the prior written consent of Applikon Dependable Instruments B.V.		DIMENSIONS ARE IN mm
A.D.I. B.V. ☒ P.O. BOX 149 3189 AC SCHEDAM HOLLAND		(31)10-4621855	FAX (31)10-4379648	SHEET: 1 OF 1
				SIZE : A3

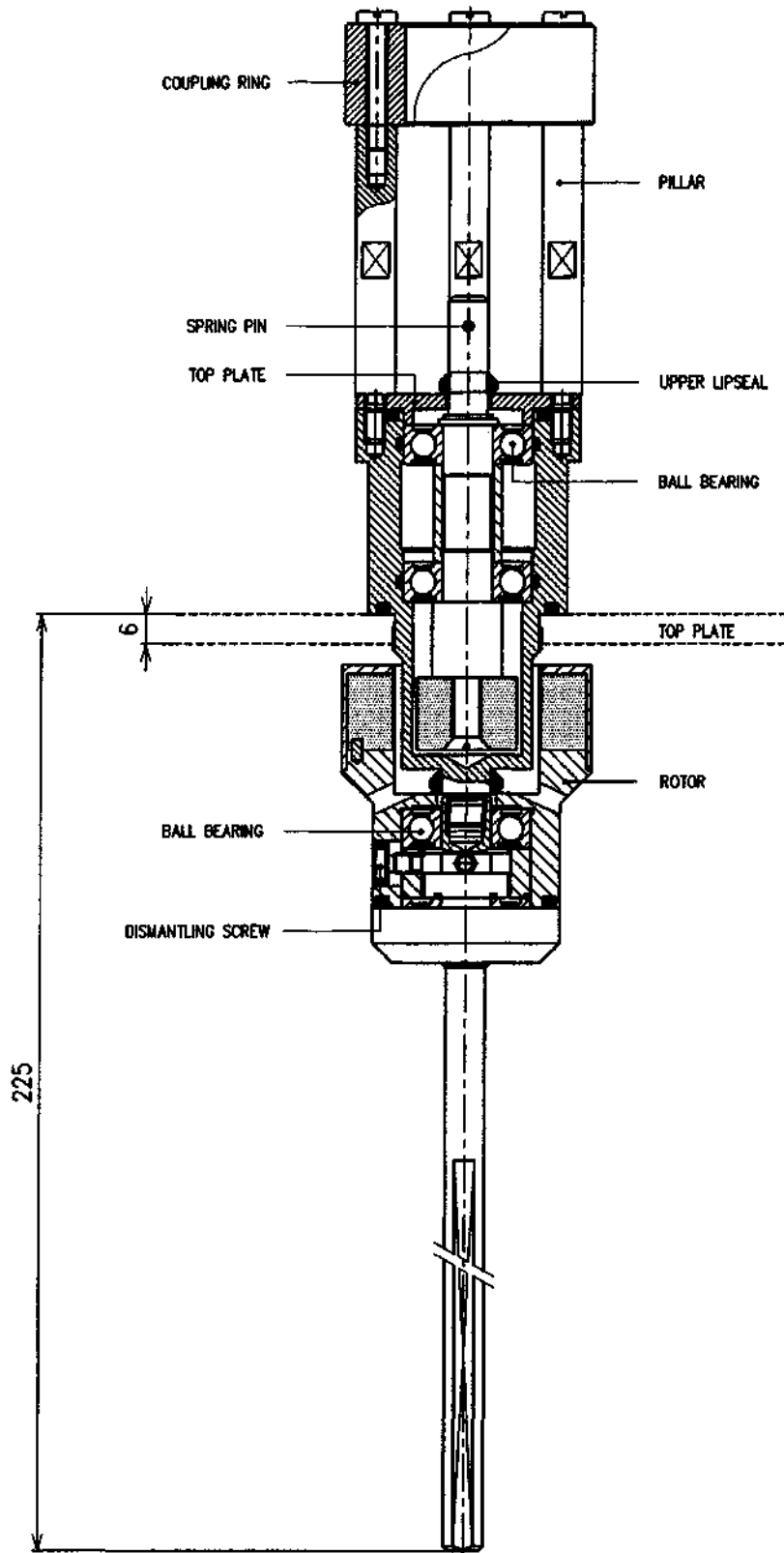

PROJECTION :	DRAWING NAME : STIRRER ASS. MAGNET COUPLED 2-5L.				
 applikon [®] DEPENDABLE INSTRUMENTS	PART NBR.:	Z81315MG03	DRAWING NBR.:	D3002-1 .06.006	
	SCALE :	1 : 1	DESIGNED :	PVe	APPR:
	CHECKED :	17 nov. 1995	DESIGNED :	MVo	SHEET: 1 OF 1
		17 nov. 1995			
© 1995 Applikon Dependable Instruments B.V. No part of this drawing may be copied or reproduced in any form or by any means or transferred to any third party without the prior written consent of Applikon Dependable Instruments B.V.					DIMENSIONS ARE IN mm
A.D.I. B.V. P.O. BOX 149 3106 AC SCHIEDAM HOLLAND (31)10-4821035 FAX (31)10-4379648					SIZE : A3

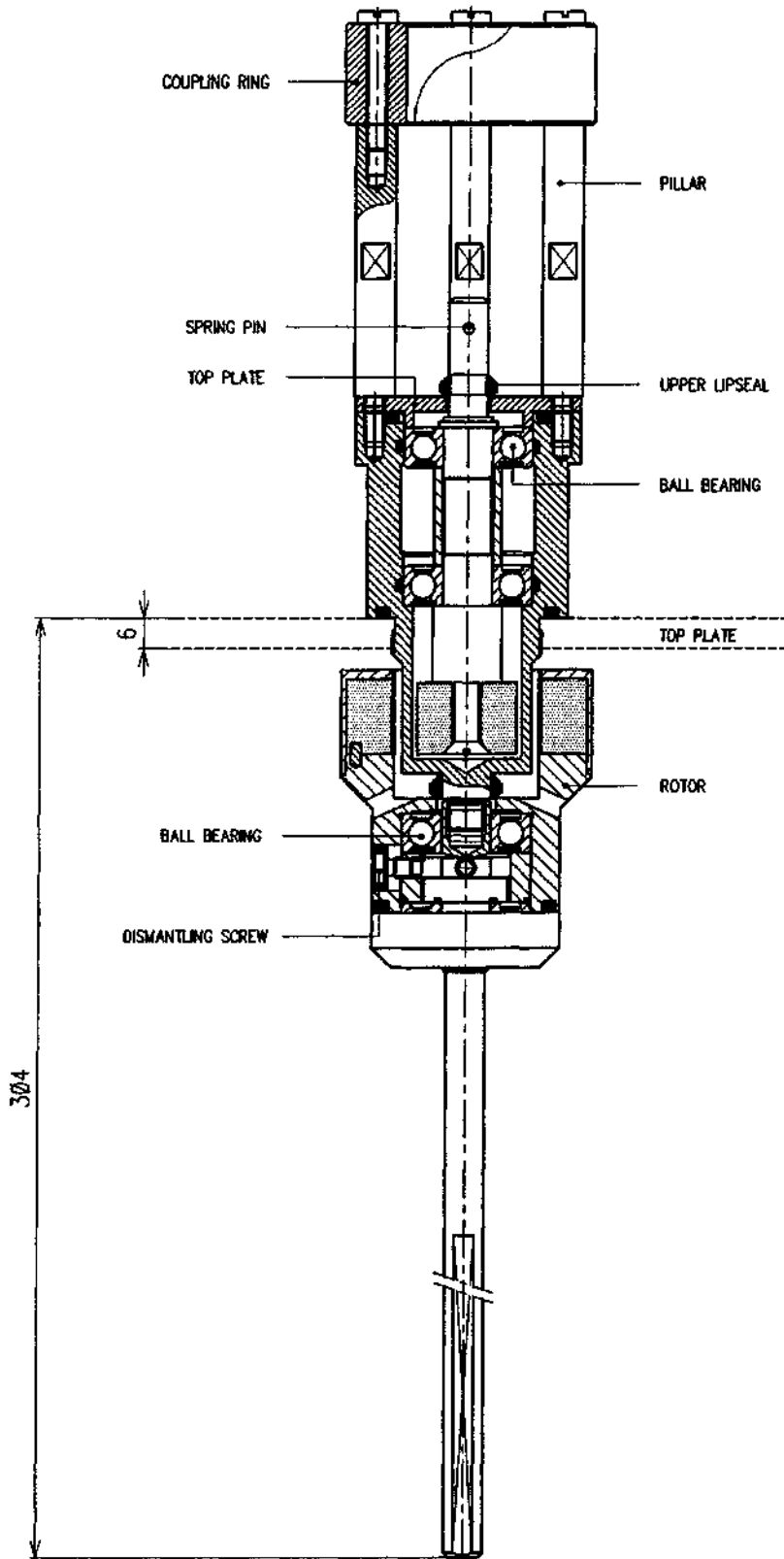

PROJECTION:	DRAWING NAME: STIRRER ASS. MAGNET COUPLED 7L.		
 applikon [®] DEPENDABLE INSTRUMENTS	PART NBR.: Z81315MG07	DRAWING NBR.: D3007-1 .06.003	
	SCALE: 1 : 1	DESIGNED: 17 nov. 1995	PVe
	CHECKED: 17 nov. 1995	MVo	APPR.: <i>MVo</i>
	© 1995 Applikon Dependable Instruments B.V. No part of this drawing may be copied or reproduced in any form or by any means or transferred to any third party without the prior written consent of Applikon Dependable Instruments B.V.		DIMENSIONS ARE IN mm
A.D.I. B.V. P.O. BOX 149 3180 AC SCHEDAM HOLLAND		(31)10-4821855 FAX (31)10-4379648	
SIZE: A3			SHEET: 1 OF 1