

Electro-pneumatic Positioners
YT-1000L Series

USER'S MANUAL

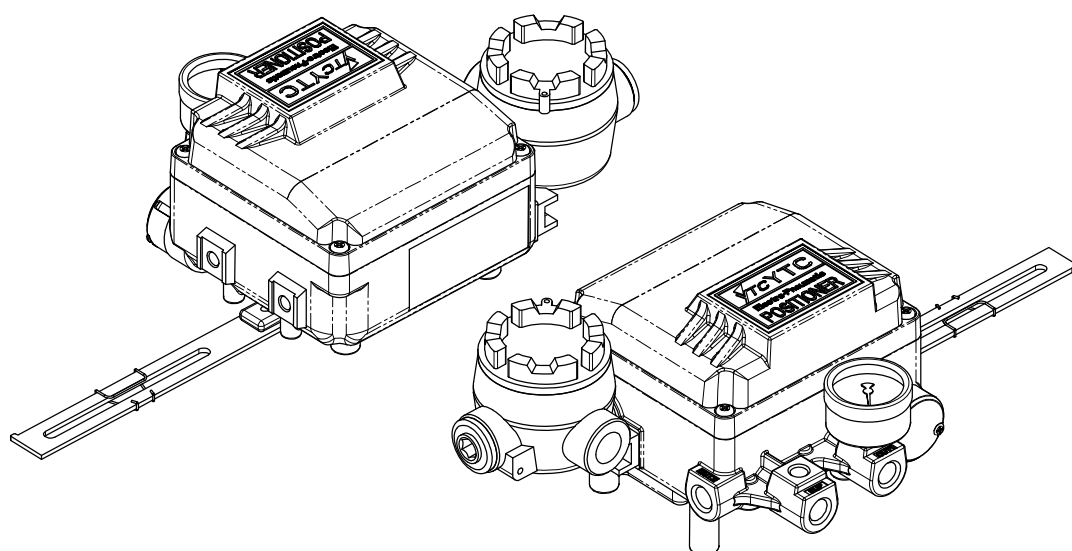

Table of Contents	
Introduction	3
Manufacturer Warranty	3
Product Description	4
Main Features and Functions	4
Operation Logic	4
Label Description	5
Suffix Symbol	5
Specification	6
Parts and Assembly	7
Dimension	8
YT-1000L: Explosion-Proof Type	8
YT-1000L: Intrinsically Safe Type	8
Installation	9
Safety Waring	9
Tools for Installation	9
YT-1000L Installation	9
Piping Connection	12
Supply Pressure Condition	12
Pipe Condition	12
Piping Connection with Actuator	12
Power Connection	13
Connection - Connection Port	13
Connection - Cable Gland	13
Connection - Power	14
Connection - Ground	14
Adjustment	15
Adjustment - Zero	15
Adjustment - Span	15
Adjustment - A/M Switch (Automatic/Manual)	15
Adjustment - Seat Adjuster	15
Adjustment - Orifice	16
Troubleshooting	17

Introduction

Thank you for choosing YTC product. Each product is fully inspected after the production to offer you the highest quality. In order to fully utilize the product, we strongly recommend users to read this manual carefully and understood.

- The manual should be provided to the end user.
- The manual can be changed or revised without any prior notice. Any changes in product's specification, structure, and/or any components may not result immediate revised version of the manual.
- The manual should not be duplicated or reproduced for any purpose without any approval from Young Tech Co., Ltd, South Korea.

YOUNG TECH CO., LTD

Manufacturer Warranty

- For the safety, it is imperative to follow instructions in the manual. It is not manufacturer's liability for any damages which caused by users' negligences.
- It is not manufacturer's liability for any damages or accidents which resulted by any alteration or modification of the product and parts. If alteration or modification is necessary, please contact the manufacturer directly.
- Manufacturer warrants the product from the date of original retail purchase of the product for one (1) year, except as otherwise stated.
- Manufacturer warranty will not cover the products that the product have been subjected to abuse, accident, alteration, modification, tampering, negligence, misuse, faulty installation, lack of reasonable care, repair or service in any way that is not contemplated in the documentation for the product, or if the model or serial number has been altered, tampered with, defaced or removed; damages that occurs in shipment, due to act of God, failure due to power surge, and cosmetic damage. Improper or incorrectly performed maintenance or report voids this Limited Warranty.
- For detailed warranty information, please contact the corresponding local Young Tech Co., Ltd office or main office in South Korea.

Product Description

Main Features and Functions

- It is designed for high durability and performance in high vibration environment.
- Durability has proven after testing of 1 million times, at least.
- Response time is very short and accurate.
- Simple part change can set 1/2 Split Range.
- It is economical due to less air-consumption.
- Direct/Reverse action can be set easily.
- Zero & Span adjustment process is simply.
- Feedback Connection is easy.

YOUNG TECH CO., LTD

Operation Logic

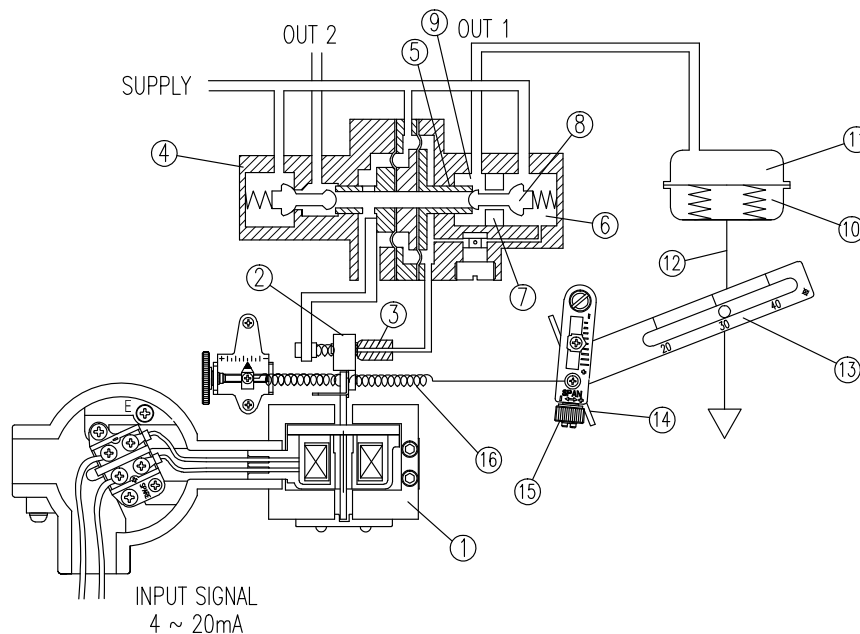

<Figure 1>

Flapper(2) pushes nozzle(3) if input pressure increases. Then the gap between the nozzle(3) and the flapper(2) increases, which results pressure in upper spool(5) exhaustion. This would cause spool(5) to rise upward. As the spool(5) rises, the air pressure will be supplied to the actuator(10). As the actuator's inner pressure increases, the actuator stem(12) will move. The movement will be transferred to cam(14) and pulls the span spring(15). The span spring(15)'s force will be balanced with torque motor(1), and this would cause to move flapper(2) to the normal position and reduce the gap between the nozzle(3). As the air pressure exhaustion level decreases through the nozzle(3), the pressure level in upper spool(5) increases again. The spool(5) would come back to the normal position and block the seat(7) which would lead to block the supply air from the actuator(10). When the actuator(10) stops the movement, the positioner would come back to the normal position. <Figure 1>

Label Description

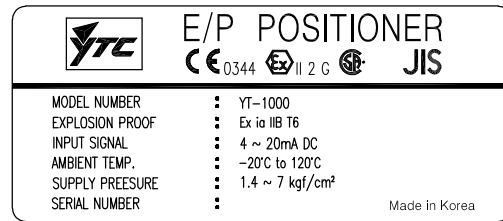
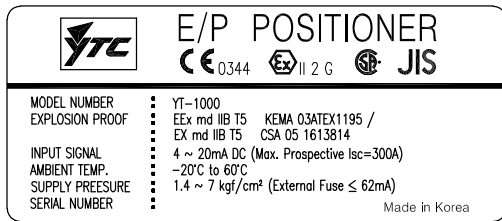

- Model Number: Indicates model name and any options (if any).
- Explosion Proof: Indicates explosion proof grade.
- Input Signal: Indicates current input signal range.
- Ambient Temperature: Indicates ambient temperature for normal operation.
- Supply Pressure: Indicates the range of supply pressure.
- Serial Number: Indicates unique serial number.

Suffix Symbol

YT-1000L series follows suffix symbols as follows.

YT-1000L [1] [2] [3] [4] [5] [6]

[1] Motion Type	S : Linear D : Double
[2] Explosion Proof	m : Ex dm IIB T5 C : Ex dm IIC T5 i : Ex ia IIB T6 n : Non-Explosion
[3] Feedback Lever	1 : 10 ~ 40mm 2 : 30 ~ 70mm 3 : 60 ~ 100mm 4 : 100 ~ 150mm
[4] Orifice	1 : Ø1 2 : Ø2 3 : None
[5] Connection Type	1 : PT 2 : NPT
[6] Ambient Temperature	S : -20 ~ 70°C H : -20 ~ 120°C L : -40 ~ 70°C

* For special specification, please contact our sales department.

Specification

Category		YT-1000L	
		Single	Double
Input Signal		4~20mA DC *1	
Impedance		250±15Ω	
Supply Pressure		1.4~7.0kgf/cm ² (20~100 psi)	
Stroke		10~150mm *2	
Air Connection		PT(NPT) 1/4	
Gauge Connection		PT(NPT) 1/8	
Conduit Entry		PF 1/2 or G 1/2	
Explosion Proof *3		Domestic : ExdmIIBT5, ExdmIICT5, ExialIBT6 ATEX: EExmdIIBT5, JIS : ExsdIIBT5 CSA : ExmdIIBT5	
Protection		IP66	
Ambient Temperature	Operating	-20~70℃, -40~60℃, -20~120℃	
	Explosion	-20~60℃	
Linearity		±1.0% F.S	
Hysteresis		1.0% F.S	
Sensitivity		±0.2% F.S	±0.5% F.S
Repeatability		±0.5% F.S	
Air Consumption		3LPM (Sup=1.4kgf/cm ² ,20psi)	
Flow Capacity		80LPM (Sup=1.4kgf/cm ² ,20psi)	
Material		Aluminum Diecasting	
Weight		2.7kg(6.1lb)	

- * Tested under ambient temperature of 20℃, absolute pressure of 760mmHg, and humidity of 65%.
Please contact us for more detailed specification.
- * 1: For 1/2 Split Control, it can be applied by adjusting zero and span.
- * 2: For inquiry regarding strokes under 10mm or above 150mm, please contact YTC.
- * 3: YT-1000L has different types of explosion proof certificates. Please make sure to check explosion proof grade.

Parts and Assembly

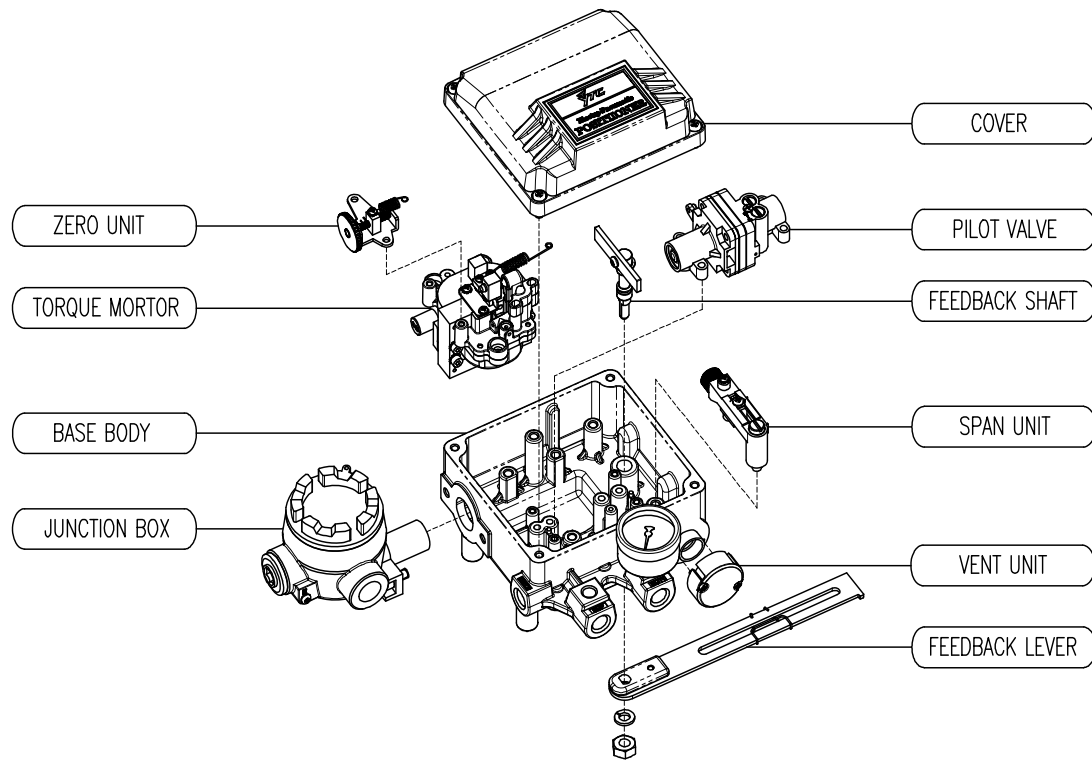

<http://www.ytc.kr>

Dimensions

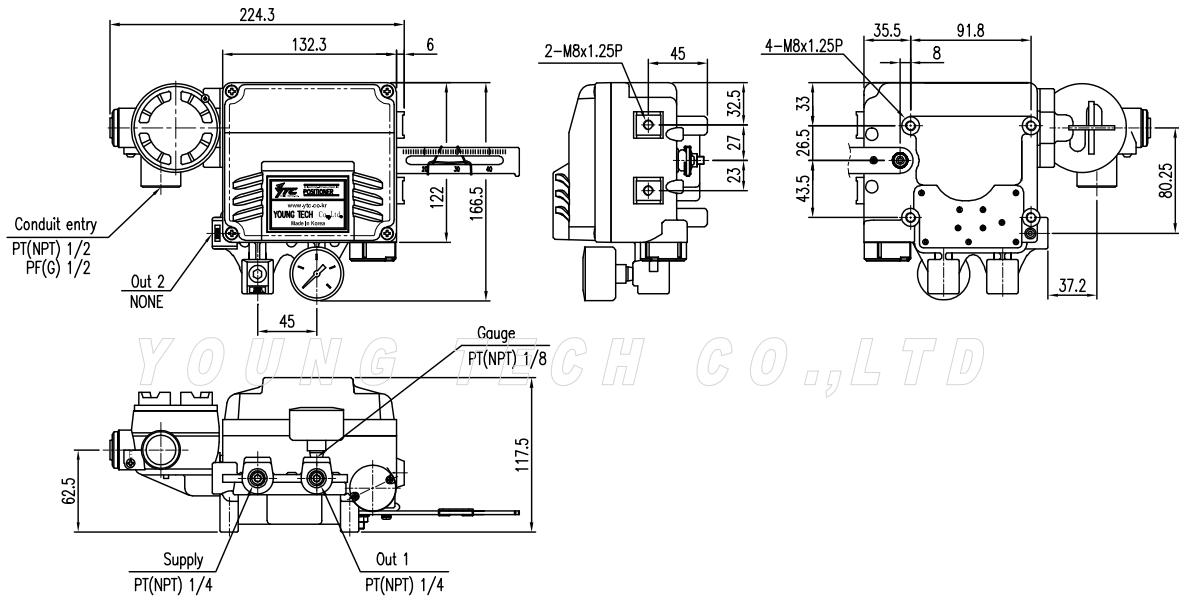

< Explosion-proof type YT-1000L >

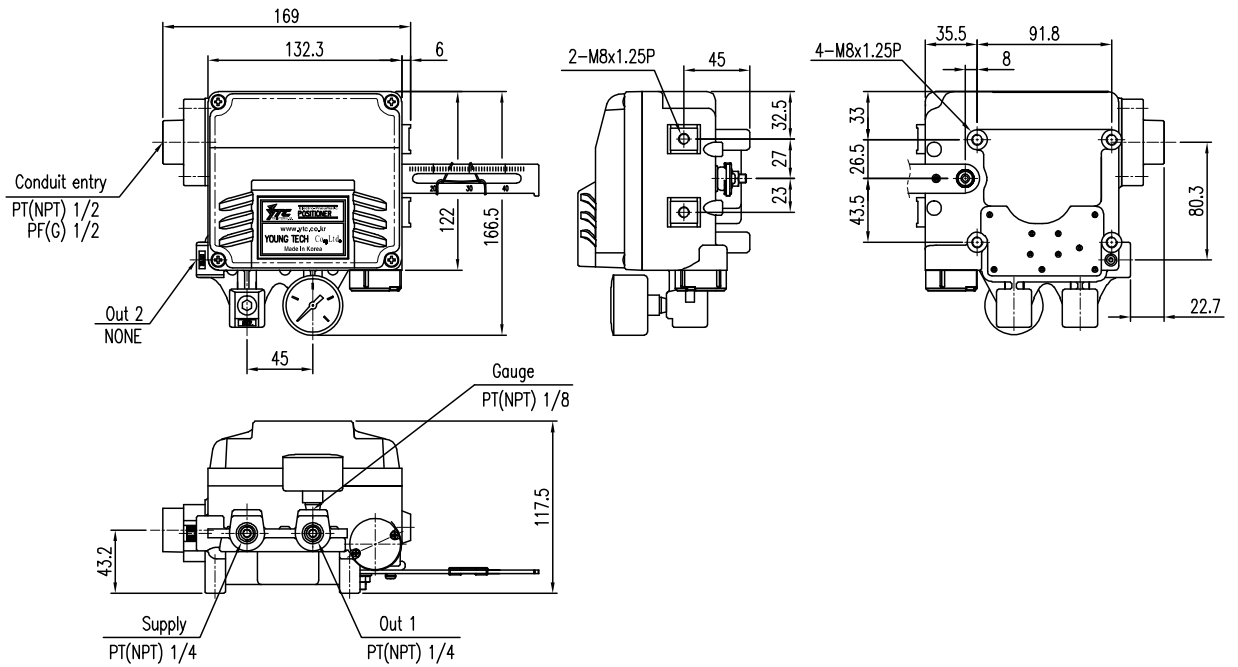

< Intrinsically safe type YT-1000L >

Installation

Safety Warning

When installing positioner, please ensure to read and follow safety instruction.

- All input and supply pressure to valve, actuator, and other related devices must be turned off.
- Use bypass valve or other equipment to avoid entire system "shut down."
- Make sure there is no remaining pressure in the actuator.

Tools for installation

- ① Hexagonal wrench
- ② Screw drivers (+) & (-)
- ③ Spanners for hexagonal-head bolts

YT-1000L installation

YT-1000L should be installed on linear motion valve such as globe valve or gate valve using spring return type diaphragm or piston actuator. Before installation, be sure to check for following installation components.

- ① YT-1000L main body
- ② Feedback lever and lever spring
- ③ Flange nut (bottom side of YT-1000L)
- ④ 4 pcs. of hexagon head bolts (M8 X 1.25P)
- ⑤ 4 pcs. of M8 plate washer

Installation Steps

(1) Proper bracket must be made in order to attach positioner on the actuator yoke. Please consider following when making a bracket.

- ① Feedback lever should be leveled at 50% of valve stroke. (Refer to Step 7)
- ② Feedback lever connection bar of actuator clamp should be installed at the position that the valve stroke and numbers which indicated on the feedback lever must be fitted. (Refer to Step 8)

(2) Attach YT-1000L to the bracket, which was produced in earlier step, by using bolts.

<Figure 2> Please refer to backside of the product for size of bolts. The standard size of bolt is M8 X 1.25P, and other bolt sizes are available. Please contact YTC sales department.

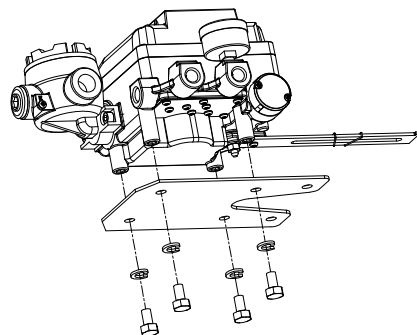

<Figure 2>

(3) Attach YT-1000L (with bracket) to the actuator yoke - DO NOT TIGHTEN COMPLETELY.

(4) Connect YT-1000L feedback lever to the actuator clamp. The gap on the YT-1000L feedback lever is 6.5mm. The connection bar thickness should be less than 6.3mm. <Figure 3>

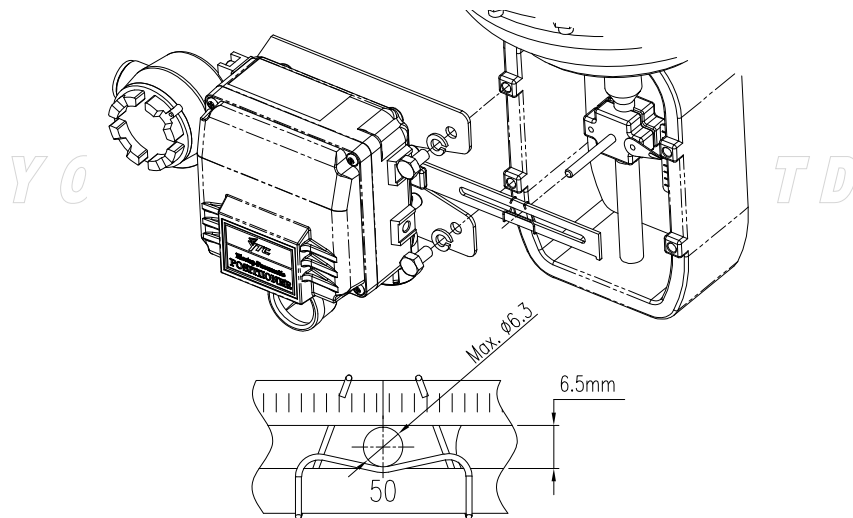

<Figure 3>

(5) Connect air filter regulator to the actuator temporarily. Set supply pressure of the regulator in order to position the actuator clamp at 50% of valve stroke.

<Figure 4>

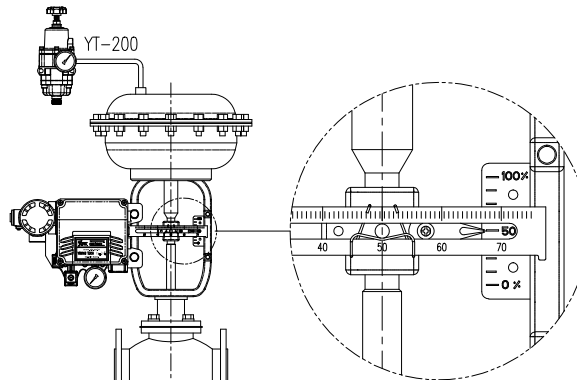

<Figure 4>

(6) Insert connection bar into the YT-1200L feedback lever. The connection bar should be inserted at the 50% point on the feedback lever, which would help to reduce hysteresis.

<Figure 5>

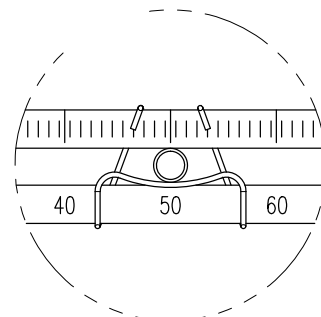

<Figure 5>

(7) If connection bar does not point at 50% point, then adjust bracket or feedback link bar position. Failure to position at 50% would lower the linearity of the positioner. <Figure 6>

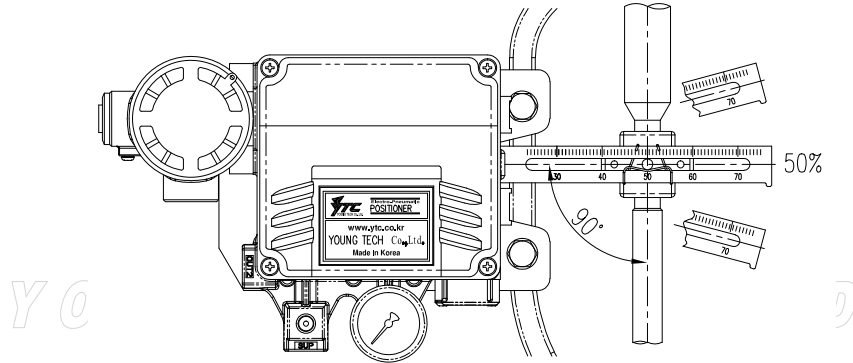

<Figure 6>

(8) Check valve stroke. The stroke numbers are indicated on the feedback lever. Position connection bar at the number on the feedback lever according to the valve stroke. <Figure 7> To adjust, move the bracket or connection bar.

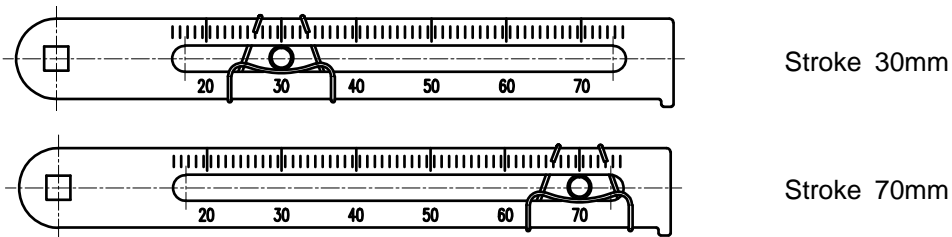

<Figure 7>

Note

After installing YT-1000L, operate the valve from 0% to 100% stroke by using air filter regulator on the actuator. Both of 0% and 100%, the feedback lever should not touch the lever stopper, which is located on the backside of YT-1000L. <Figure 8> If the feedback lever touches the lever stopper, YT-1000L should be installed further away from the center of the yoke.

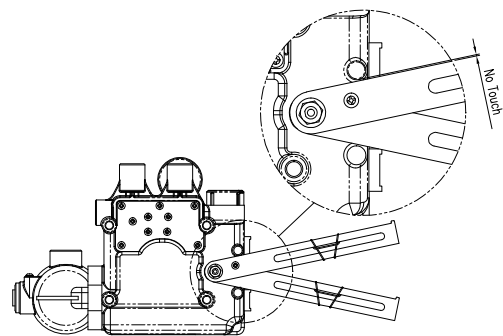

<Figure 8>

(9) After the proper installation, tighten all of the bolts on the bracket, the feedback lever, and the connection bar.

Piping Connection

Note

- To avoid entering moisture, oil, or dust into the product, please carefully make selection of supply pressure compressor.
- It is recommended to attach air filter regulator before supply port of YT-1000.

Supply Pressure Condition

- ① Dry air with at least 10°C lower than ambient temperature.
- ② Avoid from dusty air. Filter can only sort 5 micron or larger.
- ③ Avoid any oil.
- ④ Comply with ANSI/ISA-57.3 1975(R1981)이나 ISA S7.3-1975(R1981).
- ⑤ Not to be used beyond the range of 1.4 - 7 kgf/cm²(140 - 700 kPA).
- ⑥ Set air filter regulator's supplied pressure 10% higher than actuator's spring range pressure.

Pipe Condition

- ① Make sure inside of pipe is emptied.
- ② Do not use pipeline that is squeezed or has hole.
- ③ To maintain flow rate, use the pipeline that has more than 6mm inner diameter. (10mm outer diameter)
- ④ Do not use extremely long pipeline system. It may affect flow rate due to the friction inside of the pipeline.

Piping connection with actuator

YT-1000 series single acting type is set to use OUT1 port. OUT1 port should be connected with supply pressure port from actuator when using single acting type of spring return actuator. For double acting type, the piping connection can be changed due to the operation direction. Please refer to below diagrams when piping. <Figure 9~11>

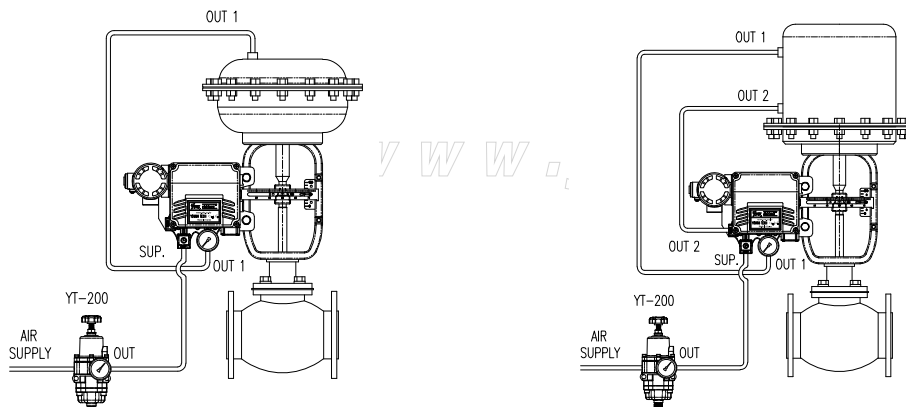

<Figure 9: Single Acting Type Actuator> <Figure 10: Double Acting Type Actuator>

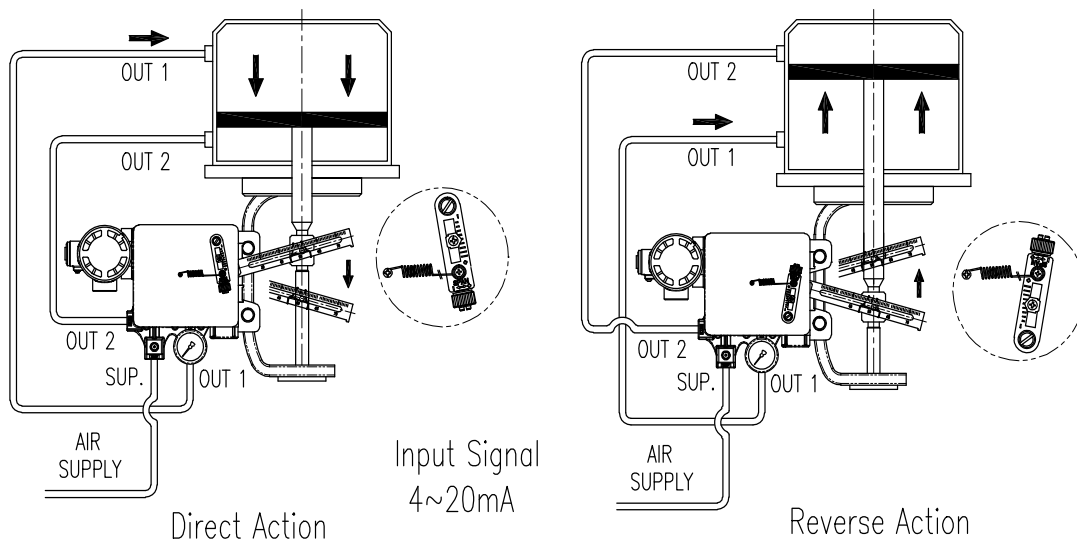

<Figure 11: Connection difference between action>

Power Connection - Explosion-Proof Type

Connection - Connection Port

- (1) Connection port size is PF1/2 or G1/2.
- (2) Make sure that the fastener bolts is tightly fastened.
- (3) Make sure to seal tightly on the connection port, and there is no leak.
- (4) When connecting explosion-proof type terminal, the number of thread must be at least six and has to be water-proof. <Figure 12>

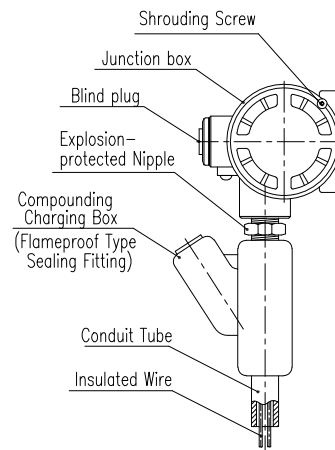

<Figure 12>

Connection - Cable Gland

- 1) Use certified explosion proof products.
- 2) End of cable must be crimp style terminal. Please refer to below table.<Figure 13>

Basic Shape of Rubber Packing Unit : mm

Nominal Size of Packing	In side Diameter of Packing (φd)	Outer Diameter of Cable
10	φ10	φ9.1~10
11	φ11	φ10.1~11

<Figure 13>

- 3) Insert the terminal connection into terminal box and lock completely.
- 4) Insert washer and rubber packing, and fasten the cable gland completely.
- 5) Fasten the clamp, then Union Grouping and Union Cover. <Figure 14>

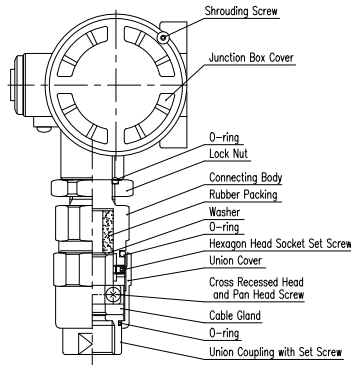

<Figure 14>

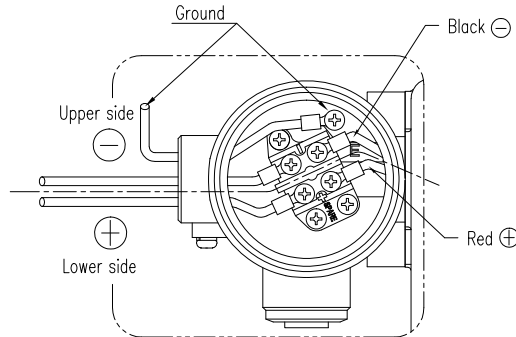

<Figure 15>

Connection - Power

- ① Open terminal box cover.
- ② Locate the poles and connect them properly. Make sure to fasten the connection.
- ③ Close back the terminal box cover. <Figure 15>

Safety Warning

YT-1000L designed under intrinsically safe procedures and restriction. However, intrinsically safe system can be damaged from electronic energies from other electronic devices. To avoid any system damages, please read the following.

- Differentiate intrinsically safe type circuit with other types of circuit clearly.
- Apply proper protection device to reduce frictions.
- If possible, minimize the use of inductance and capacitance. If they must be used, set the devices at lower level than the maximum level.
- Protect the wires from damages.
- Grounding must be done properly according to the field's procedures.

Connection - Ground

- ① Open positioner's body cover.
- ② Locate the poles and connect them properly. <Figure 16>

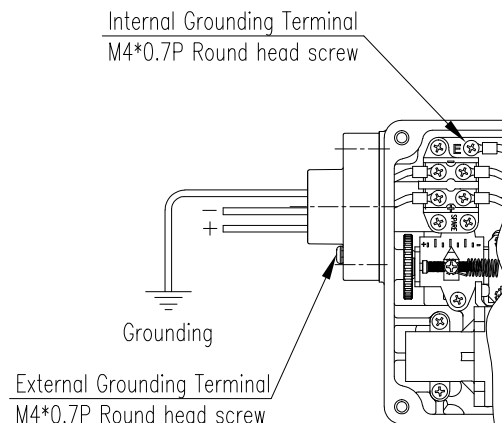

<Figure 16>

Adjustment

Adjustment - Zero Point

- ① Set supply signal at 4mA or 20mA and rotate adjuster clockwise or counter-clockwise to adjust actuator's initial point. When setting initial point, the specification of valve and system must be taken account. Please refer to <Figure 17> for increase/decrease of the zero point.

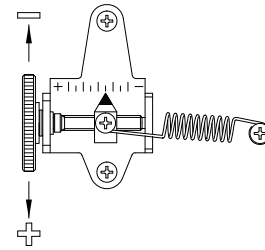

<Figure 17>

- ② When single acting actuator with spring is used, please check if the pressure level which is indicated on the positioner is same to the supplied pressure level.

Adjustment - Span

- ① After setting zero, supply 20mA or 4mA of signal. Check the actuator's stroke. If the stroke is too low, adjust the span towards '+' direction. On the other hand, if the stroke point is too high, adjust the span towards '-' direction. <Figure 18>
- ② Changing span point affects zero point setting. So zero setting must be set again. After setting zero point, confirm the span point. This step must be repeated until both points are properly set.
- ③ After setting is completed, tighten Lock Screw. <Figure 18>

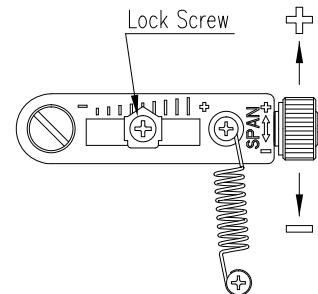

<Figure 18>

Adjustment - A/M Switch (Auto/Manual)

- ① A/M switch adjusts the valve operation to automatic or manual.
- ② When produced, YT-1000L is set at "A(Automatic)". If user prefers the positioner's setting as "M(Manual)," the setting can be changed by turning the switch counter-clockwise. <Figure 19>
- ③ If it is set as "M(Manual)", the air pressure will be supplied to the actuator directly. Always set back to "A(Automatic)" after setting change.
- ④ If OUT2 in single acting actuator or double acting actuator is used, A/M Switch will not operate.

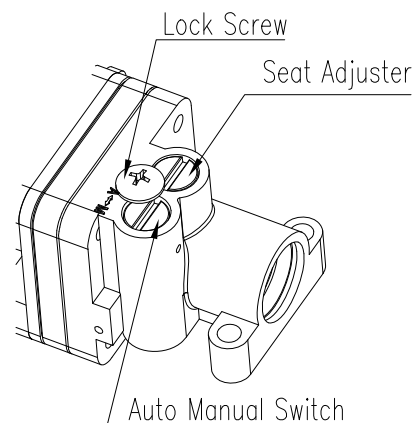

<Figure 19>

Adjustment - Seat Adjuster

- ① Seat Adjuster is set according to the customer's request before the positioner is delivered. Please do not adjust the Seat Adjuster.

- ② Seat Adjuster is used for double acting actuator always and adjusted when the pressure balance point must be changed. Please do not touch the Seat Adjuster, because it can affect the positioner's performance. <Figure 20>

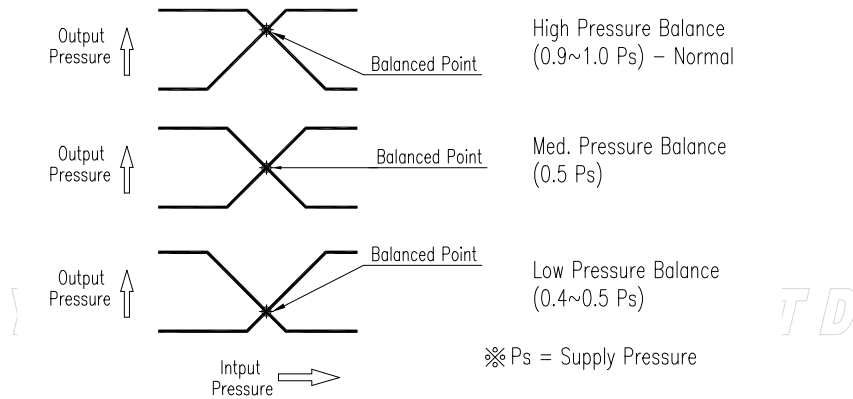

<Figure 20>

Adjustment - Orifice

- ① If the size of actuator is too small relative to the flow rate, positioner can have hunting. In order to avoid hunting, orifice can be used. There are three types of the orifice.

Actuator Size	Orifice Size	Suffix Symbol
90 cm ³ less	∅1	1
90 ~ 180 cm ³	∅2	2
180 cm ³ more	none	3

- ② Remove the o-ring from OUT1 and OUT2 port and insert appropriate orifice. After inserting orifice, place back the o-ring. Make sure there is no substance entering into port. <Figure 21>
- ③ If hunting persists after inserting the orifice, please contact YTC or its appropriate agent.

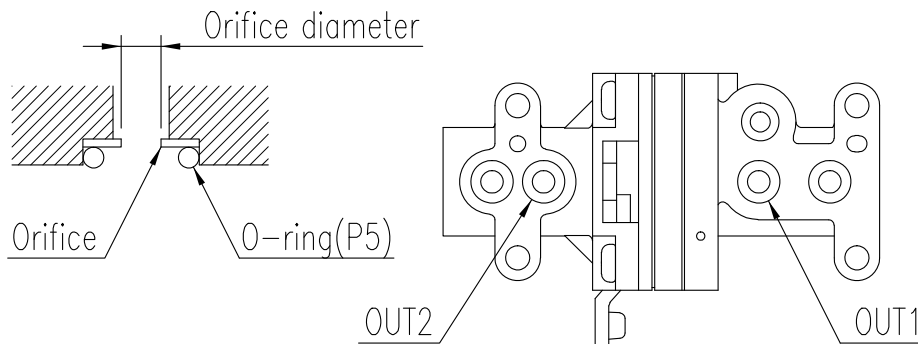

<Figure 21>

TROUBLESHOOTING

► **Positioner does not respond to the input signal.**

- (1) Check supply pressure level. The lever must be at least 1.4 kgf/cm². For spring-return type of actuator, the supply pressure level has to be larger than the spring's specification.
- (2) Check if input signal is properly supplied to the positioner. The signal should be 4~20mA DC.
- (3) Check if zero point or span point is properly set.
- (4) Check if the positioner's nozzle has been blocked. Also, check if the pressure is supplied to the positioner and the pressure is being exhausted through the nozzle. If the nozzle has been blocked by any substances, please send the product for repair.
- (5) Check if feedback lever has been installed properly.

► **The pressure of OUT1 reaches exhausting pressure level and does not come back down.**

- (1) Check A/M Switch. If the switch has been damaged, replace the switch or pilot relay valve.
- (2) Check for a gap or damages between the nozzle and the flapper. If damaged, please send the product to YTC for repair.

► **The pressure is exhausted only by A/M Switch.**

- (1) Check if the positioner's nozzle has been blocked. Also, check if the pressure is supplied to the positioner and the pressure is being exhausted through the nozzle. If the nozzle has been blocked by any substances, please send the product to YTC for repair.

► **Hunting occurs.**

- (1) Check if safety spring has been displaced. (Next to Pilot relay valve)
- (2) Check if the size of actuator is too small. If so, insert an orifice in order to reduce the pressure flow rate.
- (3) Check if there is any friction between the valve and the actuator. If so, increase actuator's size or reduce the friction level.

► **Actuator only operates by On/Off.**

- (1) Check actuator and positioner's acting type. Air pressure exhausts from YT-1000L's OUT1 port as input signal level increases. Therefore, it is standard to connect to OUT1 port when single actuator is used. Make sure the span adjustment is properly set according to the valve system.

► **Linearity is too low.**

- (1) Check if positioner is properly positioned. Especially check if the feedback lever is parallel to the ground at 50% point.
- (2) Check if zero and span point have been properly adjusted. If either one of values is being adjusted, another one must be re-adjusted as well.
- (3) Check if supply air pressure level is stable from the regulator. If the level is

unstable, the regulator must be replaced.

► **Hysteresis is too low.**

- (1) In case of double acting actuator, check if seat adjustment has been properly performed. Please contact YTC for any further inquiries regarding the seat adjustment.
- (2) Backlash can occur when the feedback lever and lever spring are loosen. To avoid backlash, please adjust the lever spring.
- (3) Check if the connection bar to the feedback lever is tightly fastened.

YOUNG TECH CO.,LTD

<http://www.ytc.kr>

Young Tech Co., Ltd

Address : #662-8 Pungmu-Dong, Gimpo-City, Kyunggi-Do, South Korea
Telephone: +82-31-986-8545
Fax: +82-31-986-2683
Website: <http://www.ytc.kr>

User Manual and other information on the documents are subjected to change without any notice.

Please visit website for most updated information.

Printed Date: June, 2007