

TURBO.DRIVE 400

Frequency Converter for
Turbomolecular Pumps

Operating Instructions 17200492_002_A5

Part Numbers

800073V0002

800073V0003

800073V0004

800073V0008

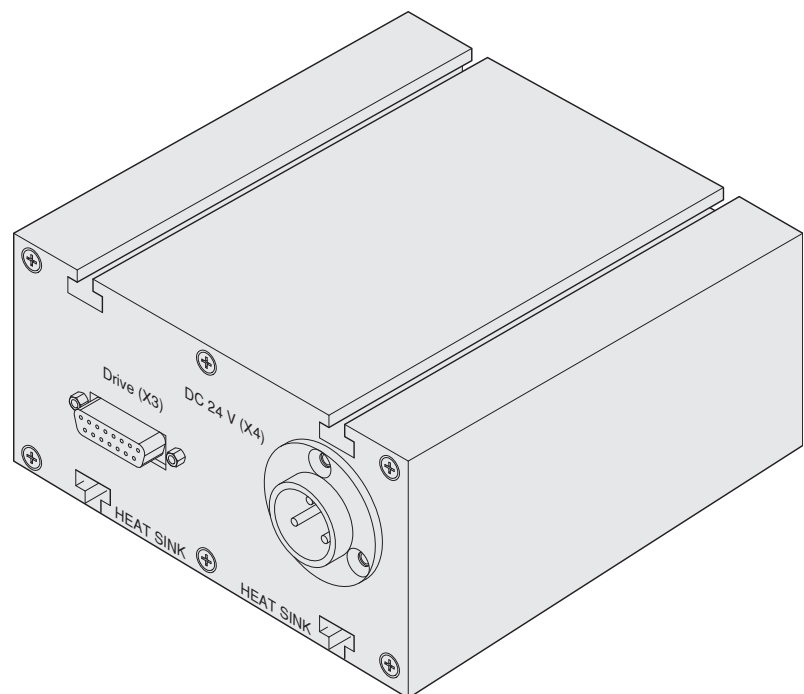

Contents

	Page
Important Safety Information	4
1 Description	7
1.1 Design and function	7
1.2 Standard equipment	7
1.3 Technical data	8
1.4 Ordering data	10
1.5 Accessories	10
2 Installation	13
2.1 Conforming utilization	13
2.2 Operating environment	14
2.3 Mounting the frequency converter	15
2.4 Connecting the pump	16
2.5 Connecting the power supply	16
2.6 Relay status	21
3 Operation	22
3.1 Start-up	22
3.2 Interfaces	23
3.2.1 RS 232 C interface (SERVICE X5)	26
3.2.2 RS 485 interface	27
3.2.3 Profibus DP	29
3.2.4 USB interface (X106)	30
3.2.5 Parameter list	31
3.2.6 Specific parameter data for the pumps	36
3.2.7 Warning codes for parameter 227	38
3.3 Switching on	40
3.4 Shutting down	41
3.5 Emergency shut down	41
3.6 Setting pumping speed and rotational speed	42
3.7 Operation at reduced current	43
3.8 Changing the frequency dependent normal operation level	44
3.9 Changing the maximum permissible run up time	45
3.10 Changing the start delay time	46
3.11 Selecting relay functions	47
3.12 Reading the error memory	47

Contents / Safety Information

4	Maintenance	48
5	Troubleshooting	49
6	Waste Disposal	57
	EC Conformance Declaration	59

Obligation to Provide Information

Before installing and commissioning the TURBO.DRIVE, carefully read these Operating Instructions and follow the information so as to ensure optimum and safe working right from the start.

The Oerlikon Leybold Vacuum **TURBO.DRIVE 400** has been designed for safe and efficient operation when used properly and in accordance with these Operating Instructions. It is the responsibility of the user to carefully read and strictly observe all safety precautions described in this section and throughout the Operating Instructions. The TURBO.DRIVE **must only be operated in the proper condition and under the conditions described in the Operating Instructions**. It must be operated and maintained by trained personnel only. Consult local, state, and national agencies regarding specific requirements and regulations. Address any further safety, operation and/or maintenance questions to our nearest office.

DANGER indicates an imminently hazardous situation which, if not avoided, will result in death or serious injury.

WARNING indicates a potentially hazardous situation which, if not avoided, could result in death or serious injury.

CAUTION indicates a potentially hazardous situation which, if not avoided, could result in minor or moderate injury.

NOTICE



DANGER



WARNING



CAUTION



Safety Information

NOTICE



NOTICE is used to notify users of installation, operation, programming or maintenance information that is important, but not hazard related.

We reserve the right to alter the design or any data given in these Operating Instructions.

The illustrations are not binding.

Retain the Operating Instructions for further use.

Important Safety Information

WARNING



The frequency converter must only be connected to power supplies which meet the requirements for functional extra low voltage with positive isolation in accordance with IEC 364 (VDE 0100, Part 410, or local regulations) (PELV).



During operation the frequency converter may attain temperatures up to 75 °C. We recommend that the unit be installed so that it can not be touched inadvertently.

Inside the unit there is the risk of suffering burns from hot components.

NOTICE



The pump may be operated only with a suitable frequency converter and suitable connecting cables.

Ensure correct polarity.

Route all cables so as to protect them from damage.

Disconnect and connect the cable connections only while the pump is turning no longer (green status LED off) and with the mains power switched off (yellow power LED off). Otherwise there is the risk of damaging the TURBO.DRIVE 400.

Description

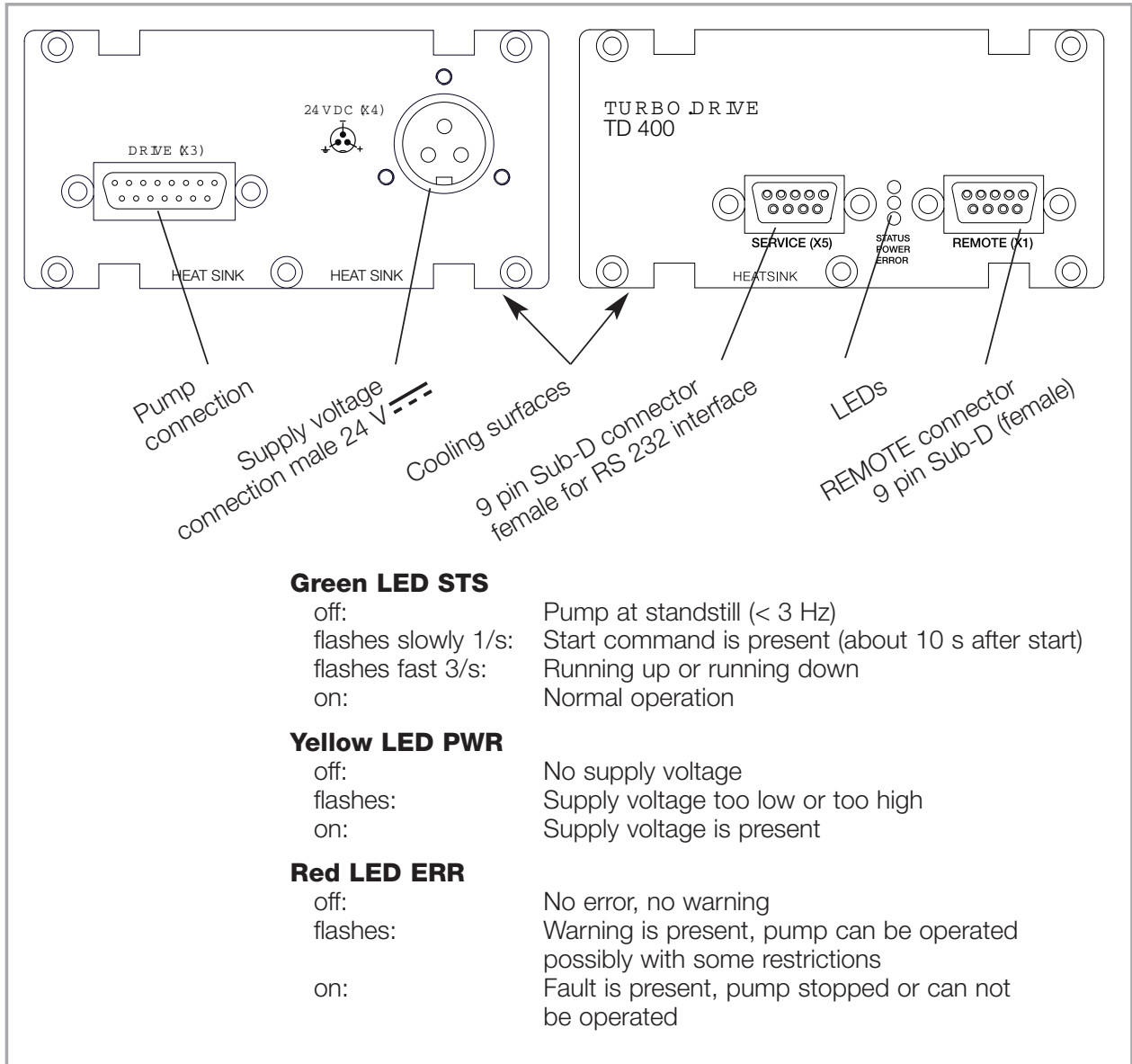

Fig. 1.1 TURBO.DRIVE 400, front and rear side

Description

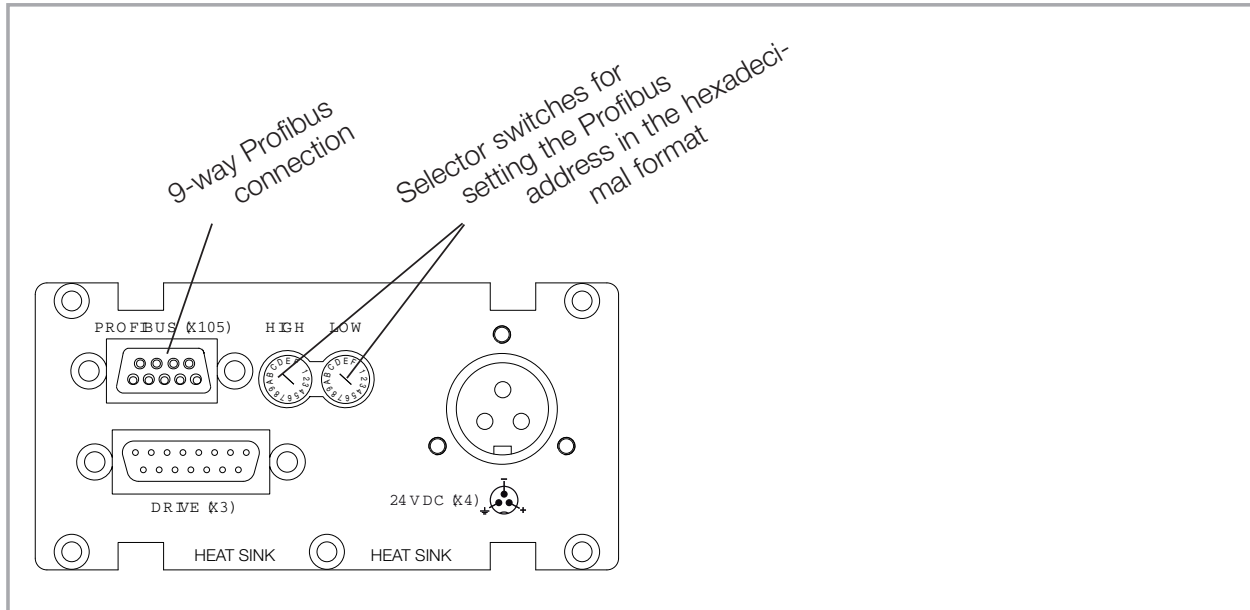

Fig. 1.2 Rear side of TURBO.DRIVE 400 with additional Profibus interface

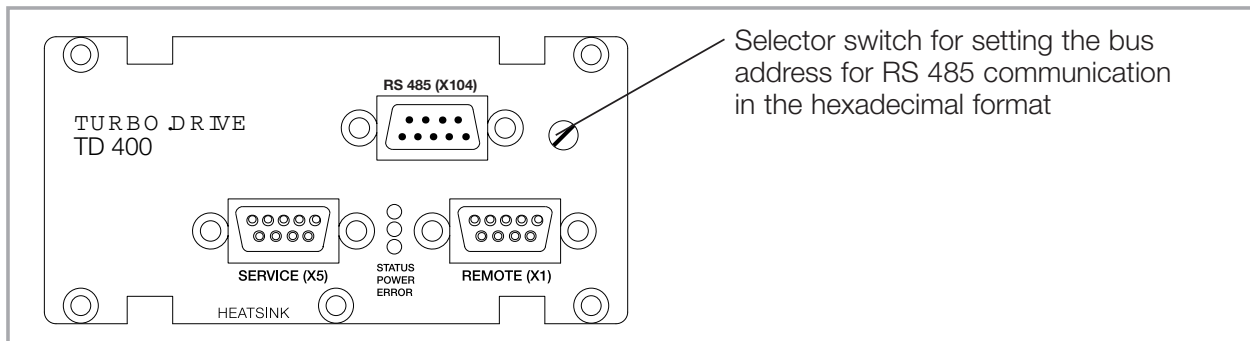

Fig. 1.3 Front side of TURBO.DRIVE 400 with additional RS 485 interface



Abb. 1.4 FTURBO.DRIVE 400 front panel with additional USB interface

1 Description

1.1 Design and function

The TURBO.DRIVE 400 supplies power to the TW and SL series turbomolecular pumps and is used to control their operation.

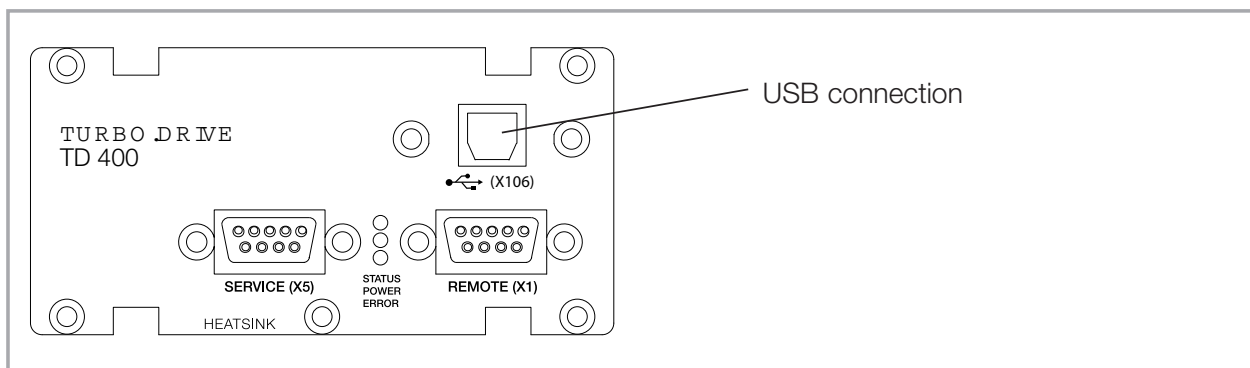
The TURBO.DRIVE 400 is either integrated in the pump or it is separate and linked to the pump by means of a connecting cable.



The TURBO.DRIVE 400 requires a supply voltage of 24 V DC. It is equipped with interfaces for programmable controls (REMOTE) and an optional interface for serial communication.

1.2 Standard equipment

Included with the delivery are the DC connector Hirose HS16P-3, four moving nuts M4 for affixing the frequency converter and the Operating Instructions.

Description

1.3 Technical data

Supply voltage	24 V  ($\pm 10\%$)
Residual ripple	
< 3 %	
Output	
Voltage	0 - 24 V 3~
Power	160 W
Frequency	0 - 1500 Hz
When operating a TW 300, TW 300 H, TW 220/150/(15) S, SL 300	
Nominal voltage	24 V 
Max. power consumption	
190 W	
Max. peak current, input side	8 A DC
Required power output from the power supply	≥ 200 W
When operating a TW 70 H, TW 250 S. SL 80	
Nominal voltage	24 V 
Max. power consumption	
140 W	
Max. peak current, input side	6 A DC
Required power output from the power supply	≥ 150 W
Max. length of the DC cable (shielded)	
at 3 x 1.5 mm ²	5 m
at 3 x 2.5 mm ²	20 m
Relay output rating	42 V, 0.5 A
Ambient temperature	
during operation	5 - 45 °C
storage	- 15 - + 70 °C
Relative air humidity	5 to 85 % non condensing
Overvoltage category	I
Contamination grade	2
Temp. of the cooling surface	5 - 55 °C
For Part Nos. 800073V0004	5 - 50 °C
Power consumption	≤ 20 W
Type of protection	IP 20
Weight, approx.	0.7 kg

Description

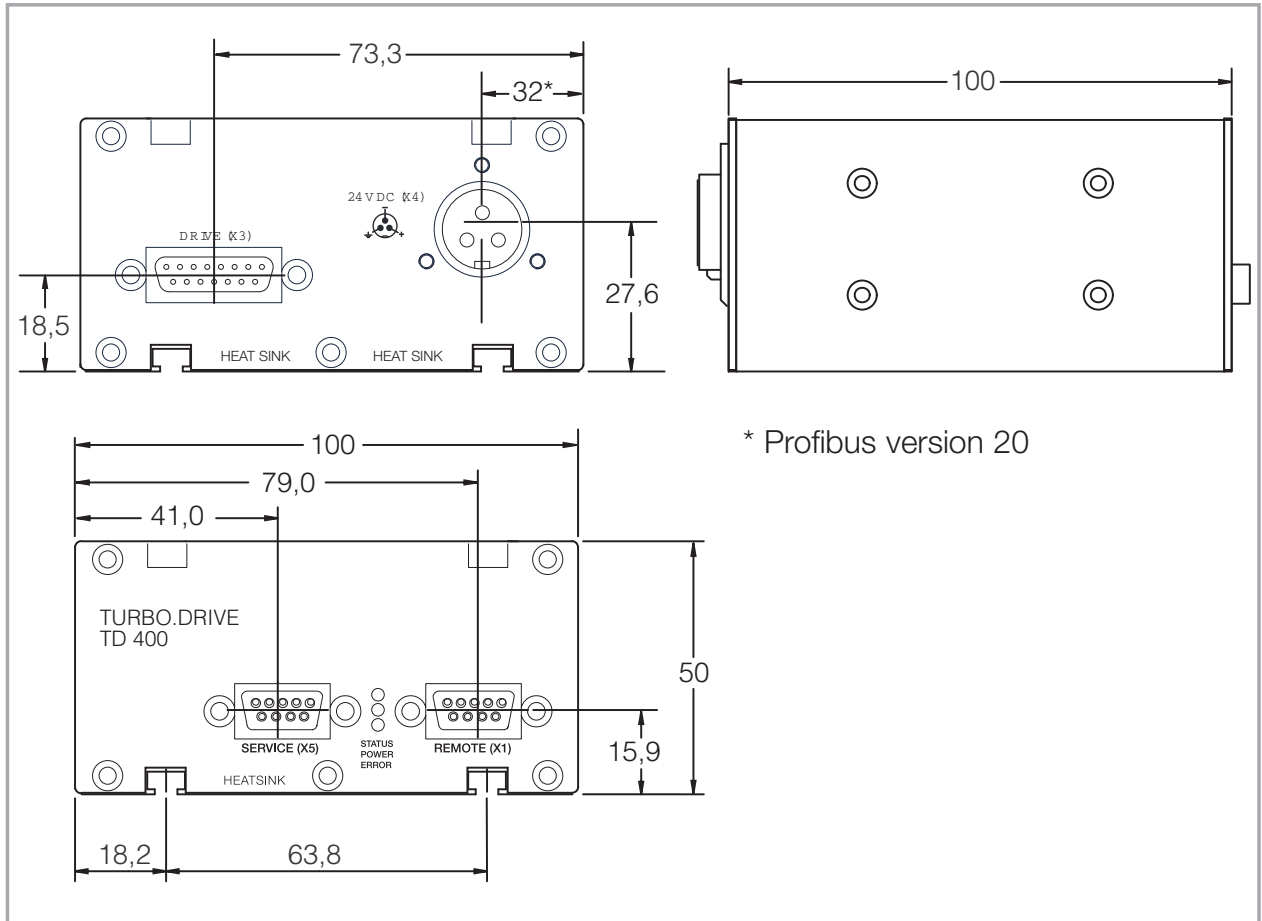
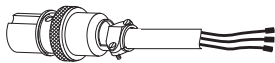
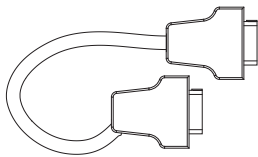
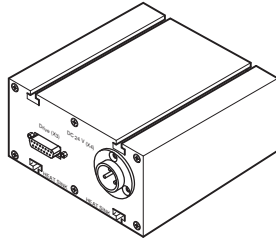

Fig. 1.5 Dimensional drawing for the frequency converter; dimensions in mm

Description



1.4 Ordering data

Frequency converter TURBO.DRIVE 400

with RS 232 C interface	800073V0002
with RS 485 C interface	800073V0003
with Profibus interface	800073V0004
with USB interface	800073V0008

Connecting cable pump - frequency converter

1.0 m long	152 47
2.5 m long	864 49
3.0 m long	864 40
5.0 m long	864 50

1.5 Accessories

OEM power supply (with screw terminals)

SITOP 24 V / 10 A (120/230 VAC / 50/60 Hz) 152 50

■ supplies the TURBO.DRIVE 400 with 24 V DC

■ other power supplies on request

24 V DC cable

(TURBO.DRIVE 400 – OEM power supply)

3 m	200 12 732
5 m	200 12 733
10 m	200 12 734
20 m	200 12 735

Mains cable for power supply, 2 m long

with EURO plug 800102V0001

with US plug 5-15P 800102V1001

Description

Power supply unit - plug and play

TURBO.POWER 300 800100V0002

- supplies the TURBO.DRIVE 400 with 24 V DC
- plug & play cables
- desktop unit or rack mountable

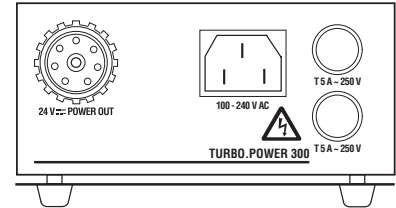

24V DC Power cable TURBO.DRIVE 400 – TURBO.POWER 300)

1 m	800094V0100
3 m	800094V0300
5 m	800094V0500
10 m	800094V1000
20 m	800094V2000

Mains cable for TURBO.POWER 300, 3 m long

with EURO plug	800102V0002
with US plug 6-15P	800102V1002
with UK plug	800102V0003

Power supply and control unit

TURBO.CONTROL 300 800100V0001

- supplies the TURBO.DRIVE 400 with 24 V DC
- plug & play cables
- desktop unit or rack mountable
- with power switch
- with start/stop switch for the turbomolecular pump
- remote control
- status LEDs and status relays

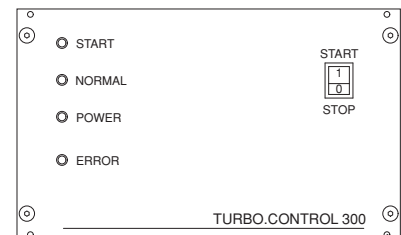

24V DC Control cable (TURBO.DRIVE 400 – TURBO.CONTROL 300)

1 m	800091V0100
3 m	800091V0300
5 m	800091V0500
10 m	800091V1000
20 m	800091V2000

Mains cable for TURBO.CONTROL 300, 3 m long

with EURO plug	800102V0002
with US plug 6-15P	800102V1002
with UK plug	800102V0003

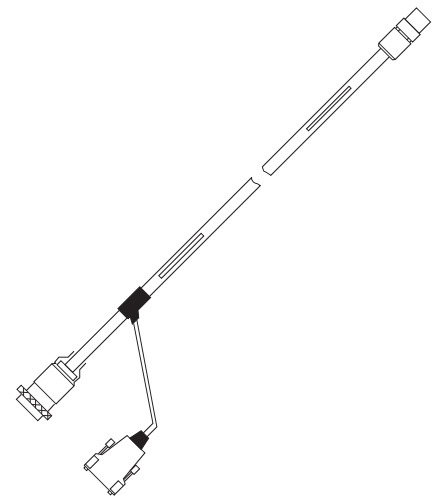

Description

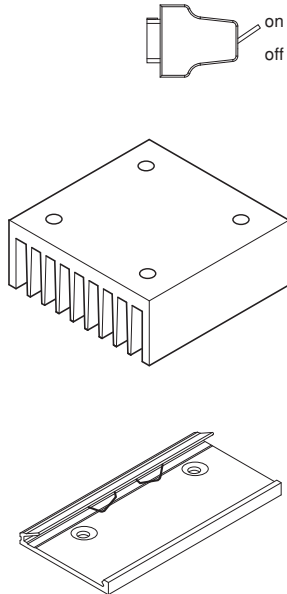

Mechanical accessories

Plug for connector REMOTE with integrated **ON/OFF switch** for the pump
(Sub-D plug, 9 way) 152 48

Heat sink for frequency converter 800110V0001

Top hat rail adaptor (mounting aid for TURBO.DRIVE 400 and TURBO.POWER 300)
800110V0003

Accessories for serial interfaces

USB driver: the Windows driver can be downloaded from www.oerlikon.com after selecting menu item www.oerlikon.com in the menu Oerlikon Leybold Vacuum → Documentation → Download Software

PC software "Turbo.Drive Server" for Windows 95 and higher, CD-ROM

- Display, change, save and compare parameter lists
- Integration of customer's software
- Record parameter data 800110V0102

(new parameter library for TURBO.DRIVE 400 is required, please ask us for a quotation)
The software can also be downloaded from www.oerlikon.com in the menu Oerlikon Leybold Vacuum → Documentation → Download Software

GSD file for Profibus DP upon request
The software can also be downloaded from www.oerlikon.com in the menu Oerlikon Leybold Vacuum → Documentation → Download Software

2 Installation

2.1 Conforming utilization

The TURBO.DRIVE 400 supplies power to the TW series turbomolecular pumps and is used to control their operation.

The TURBO.DRIVE 400 is suited for operation of the following pumps:

- TURBOVAC TW 70 H
- TURBOVAC TW 220/150 S, TW 220/150/15 S, TW 400/300/25 S
- TURBOVAC TW 250 S
- TURBOVAC TW 290 H
- TURBOVAC TW 300, TW 300 H
- TURBOVAC SL 80, SL 300

Other pumps may only be operated after approval from Oerlikon Leybold Vacuum or if the operation of such pumps is expressly permitted in the Operating Instructions for the specific pump.

The TURBO.DRIVE may only be operated with power supply units which meet PELV (Safety Extra Low Voltage) requirements.

The TURBO.DRIVE must only be opened by certified Oerlikon Leybold Vacuum Service Centres. Opening by unauthorised personnel voids warranty.

Installation

2.2 Operating environment

See also Chapter 1.3 Technical Data.

Places of installation up to 1000 m above sea level (3300 ft) are possible without restrictions. At altitudes over 1000 m heat dissipation by the ambient air is impaired. Please consult us.

If the TURBO.DRIVE 400 has been integrated in the pump, it is cooled by the pump.

As to the cooling requirements for the separately fitted TURBO. DRIVE see Fig. 2.1. The bottom side of the frequency converter must not be allowed to attain too high temperatures; see technical data.

Max. magnetic induction levels are 15 mT, max. radioactive radiation spec. is 10^5 rad (10^3 Gy).

The frequency converter must only be used in rooms within buildings. It must not be operated in explosive gas atmospheres.

The frequency converter and the connecting lines must be protected against exposure to sprayed and condensing water.

CAUTION



During operation the frequency converter may attain temperatures up to 75 °C. We recommend that the unit be installed so that it can not be touched inadvertently.

Owing to the small quantity of combustible material and the proven safety of the instrument by testing in accordance with EN 61010, the risk through fire and burning can almost completely be excluded.

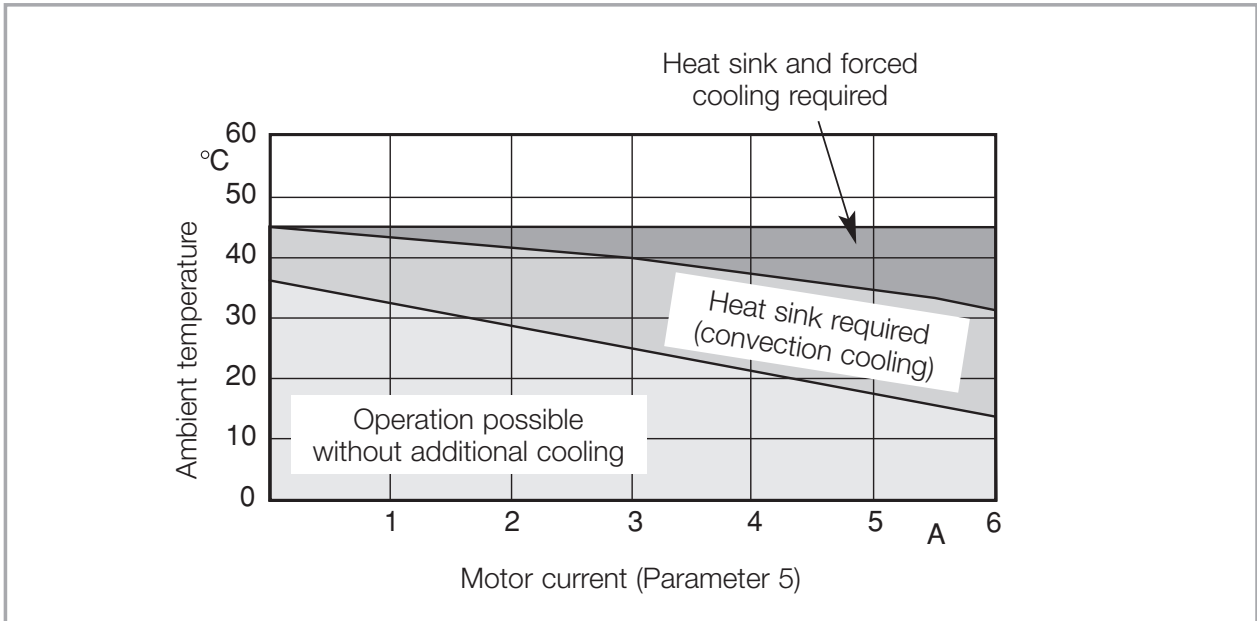

Fig. 2.1 Cooling requirements for the TURBO.DRIVE 400 when fitted separately

2.3 Mounting the frequency converter

The frequency converter may be affixed with the aid of the enclosed M4 sliding nuts. The bottom side of the frequency converter must be cooled sufficiently.

Ensure an adequate supply and discharge of cooling air.

For special requirements please contact us.

Installation

2.4 Connecting the pump

In the case of a separately fitted TURBO.DRIVE 400 connect the pump using the connecting cable.

NOTICE



The pump may be operated only with a suitable frequency converter and suitable connecting cables.

Route all cables so as to protect them from damage.

Disconnect and connect the cable connections only while the pump is turning no longer (green status LED off) and with the mains power switched off (yellow power LED off). Otherwise there is the risk of damaging the TURBO.DRIVE 400.

2.5 Connecting the power supply

WARNING



The frequency converter must only be connected to power supplies which meet the requirements for functional extra low voltage with positive isolation in accordance with IEC 364 (VDE 0100, Part 410, or local regulations) (PELV).

The power supply must meet the requirements given in Section 1.3. Peak currents in the kHz range may be present on the DC side. The power supply should have a current limiter of the current regulated type.

Connect the frequency converter to the 24 V DC power supply or to the TURBO.CONTROL 300 or to the TURBO.POWER 300 via the 24 V DC cable.

NOTICE



Ensure correct polarity.

Pin 1 + 24 VDC

Pin 2 0 V

Pin 3 GND

The frequency converter is equipped with an internal 8 AT (slow blow) fuse. It can only be replaced by Oerlikon Leybold Vacuum staff.

Connect the power supply to the mains.

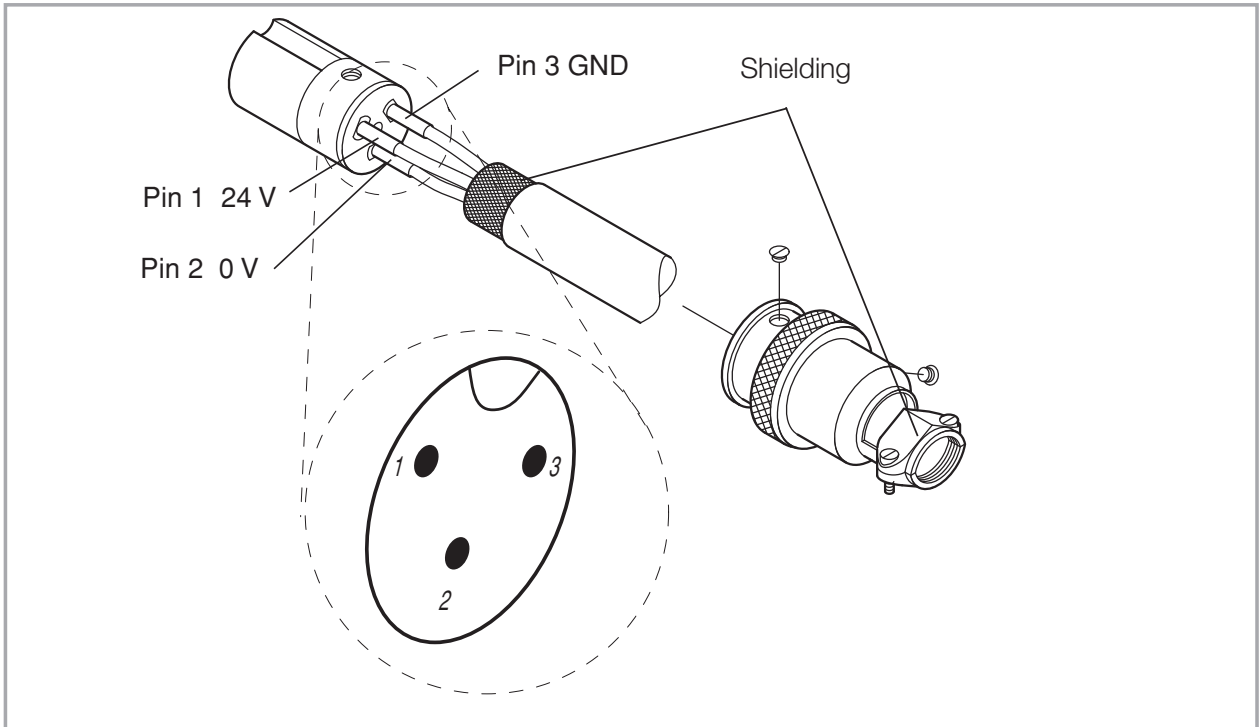

Fig. 2.2 Pin assignment of the DC connector (X4) Model Hirose HS16P-3

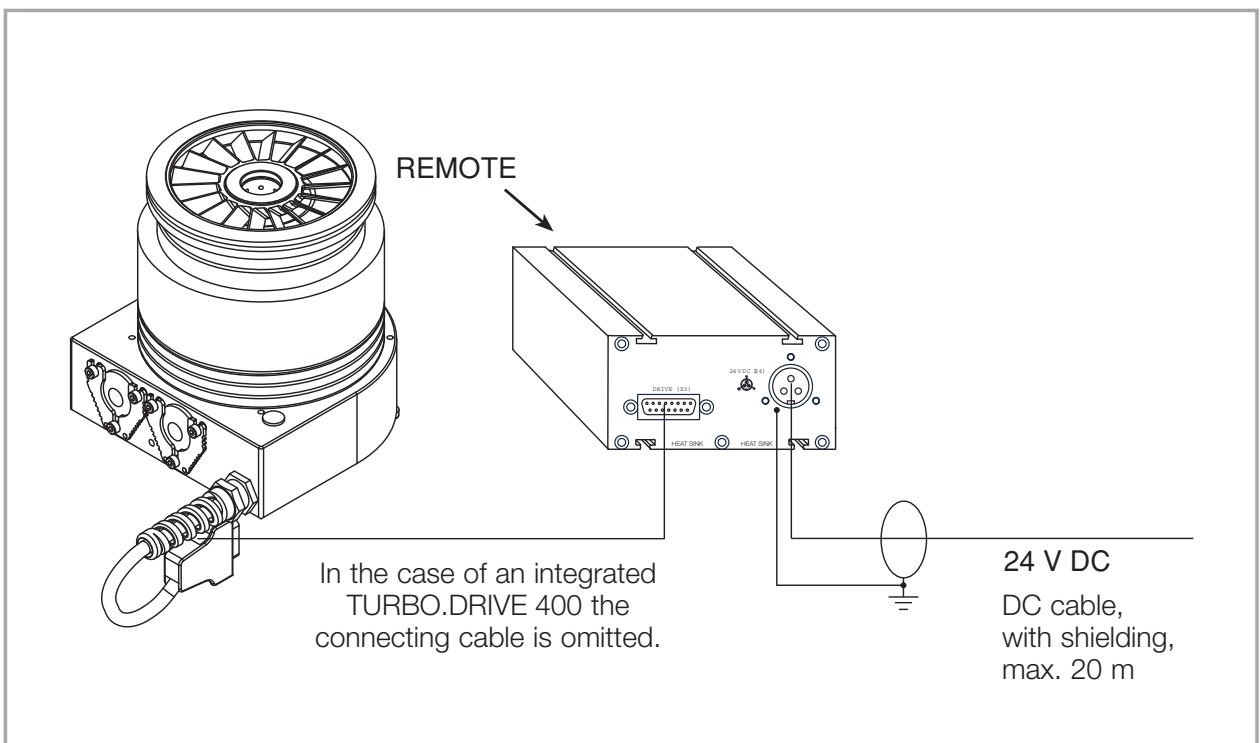

Fig. 2.3 Connecting the pump and the power supply

Installation

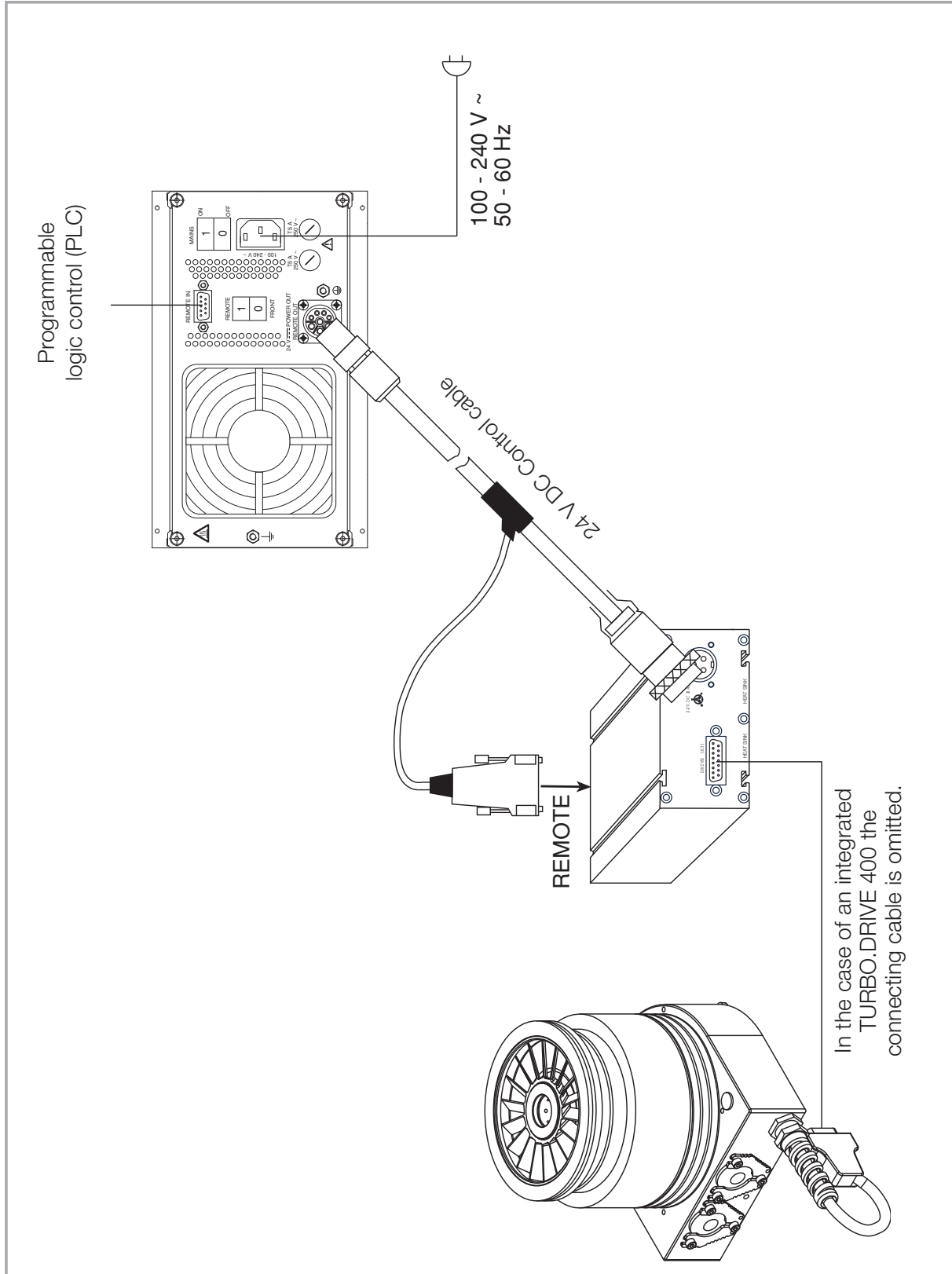

Fig. 2.4 Connecting the pump and the TURBO.CONTROL 300

Installation

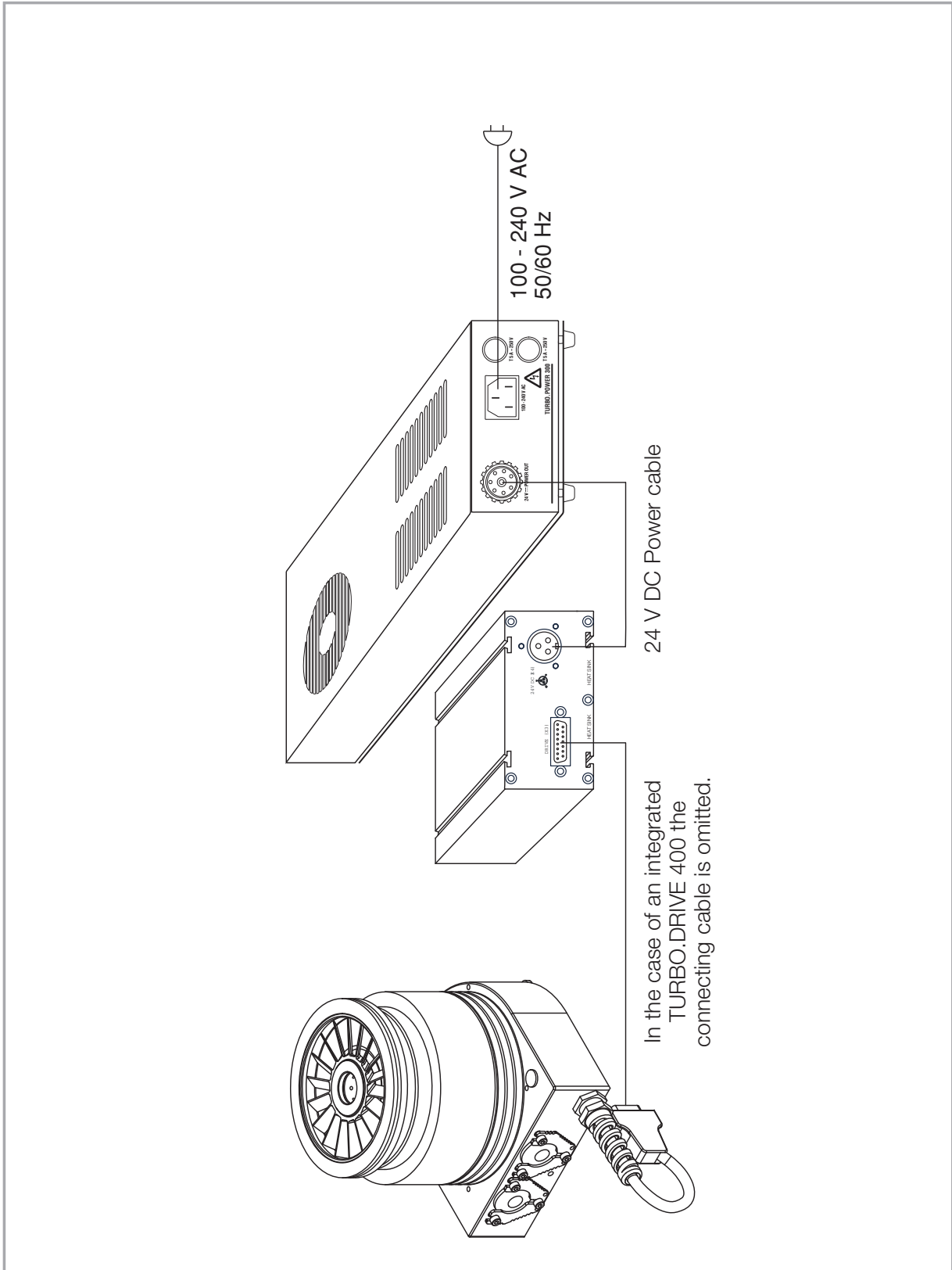

Fig. 2.5 Connecting the pump and the TURBO.POWER 300

Installation

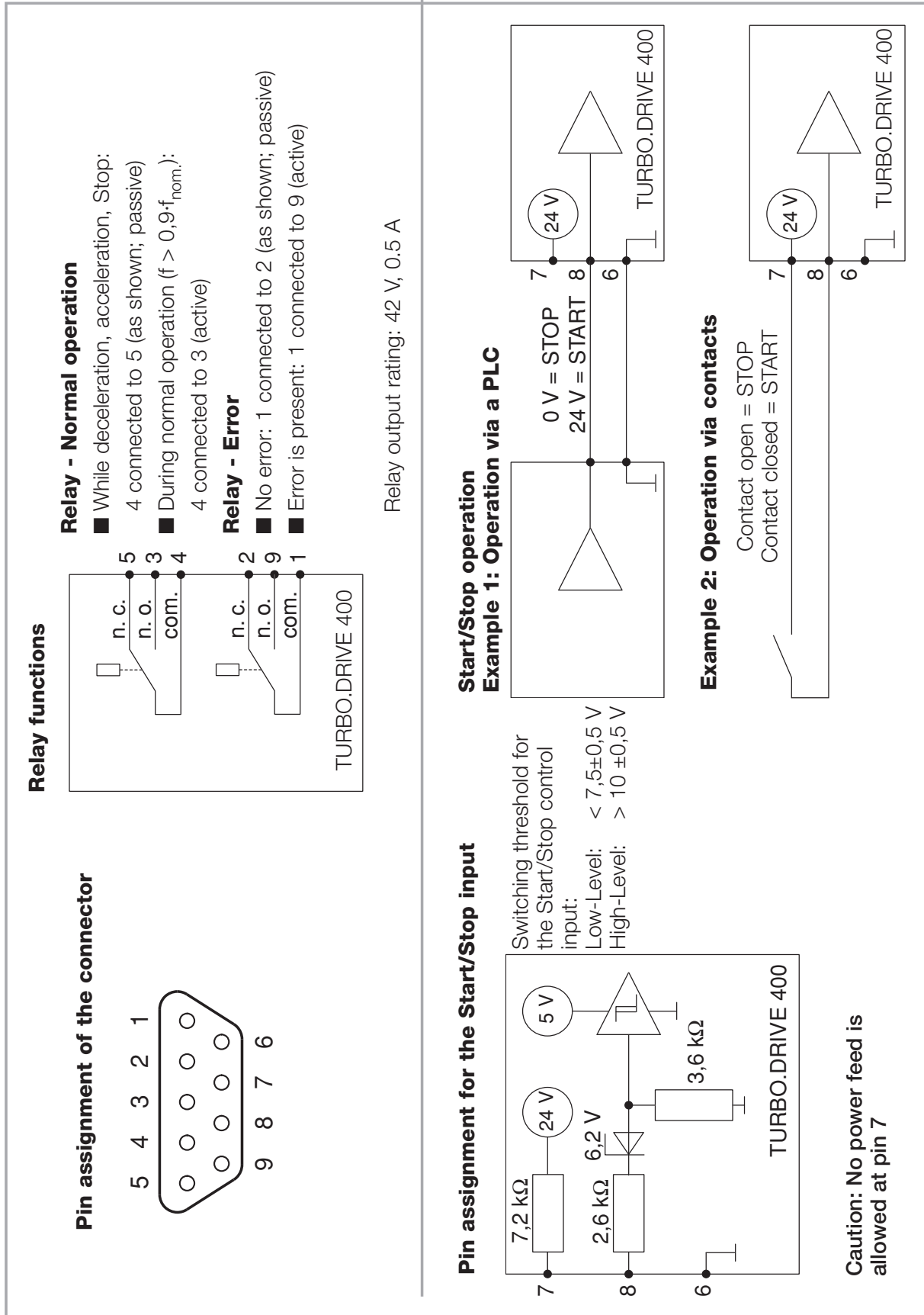

Fig. 2.6 Pin assignment of the REMOTE (X1) connector

2.6 Relay status

Input data / status		Output data				Operating mode			
Start/ stop signal	Pump rotating	Normal frequency ≥ 90% of setpoint frequency	Error is present	Motor drive	Relay NORMAL OPERATION	Relay ERROR	LED STATUS (green)	LED ERROR (red)	
Stop	no	no	no	off	passive	passive	off	off	Pump not operating
Stop	yes	no	no	off	passive	passive	flashes	off	Pump is decelerating
Stop	yes	yes	no	off	passive	passive	flashes	off	Just after stop; pump was in the normal operating mode before that
Start	no	no	no	on	passive	passive	off	off	Just after start
Start	yes	no	no	on	passive	passive	flashes	off	Pump is accelerating
Start	yes	yes	no	on	active	passive	green	off	Pump is in the normal operating mode
Stop	no	no	yes	off	passive	active	off	red	Error is present; pump is at standstill
Stop	yes	no	yes	off	passive	active	flashes	red	Error is present; pump is decelerating
Stop	yes	yes	yes	off	passive	active	flashes	red	Error has just occurred
Start	no	no	yes	off	passive	active	off	red	Error is present; pump is at standstill
Start	yes	no	yes	off	passive	active	flashes	red	Error is present; pump is decelerating
Start	yes	yes	yes	off	passive	active	flashes	red	Error has just occurred

Other modes are not possible; they indicate a failure affecting the TURBO.DRIVE 400.

Installation

3 Operation

3.1 Start-up

The TURBO.DRIVE 400 offers the possibility of gently running in pumps which were not operated for a period between 6 and 12 months.

For this set the parameter P119 “Bearing run-in function” to 1; thereafter start this function through the start command.

All three LEDs will flash rapidly, during acceleration the green LED flash more slowly.

The run can be cancelled by revoking the start command. Pausing is not possible.

After a completed run-in the pump stops. The LEDs continue to flash.

Parameter 119 remains set after the run and needs to be set manually to 0.

In all, the entire bearing run-in process may take up to 4 hours.

Turbomolecular pumps which were not operated for a period of over 12 months should be returned to us. For more information on this please contact your local sales partner.

3.2 Interfaces

The frequency converter has a RS 232 interface as standard (SERVICE X5) and is optionally equipped with serial interfaces:

- RS 485 C
- Profibus DP
- USB

The TURBO.DRIVE 400 is configured through the parameters according to the parameter list. Pxxx denotes parameter value xxx.

The PC software "TURBO.DRIVE Server" allows convenient access by the user to the parameters of the frequency converter. It can be downloaded from www.oerlikon.com in the menu Oerlikon Leybold Vacuum → Documentation → Download Software.

Interfaces priority level

The optional interface has the highest priority level, followed by the Service interface X5. The Remote input X1 has the lowest priority level. See also parameter 179 in Section 3.2.4.

Operation

Applications which can be implemented with the aid of the serial interface:

Application	Benefits to the customer	How to do it
Networking of several pumps and other equipment	Savings relating to the costs for signalling cables	With Field Bus systems like Profibus
Automation	Savings related to repetitive manual work	For example by a control computer
Avoidance of warnings and warnings before overload operation and early detection of a failing pump	<ul style="list-style-type: none"> ■ Precise planning for maintenance ■ Improved reliability of sensitive production processes in a vacuum 	Monitoring of: <ul style="list-style-type: none"> ■ Motor current P5 ■ Ball bearing temperature P125 or P127 ■ Motor temperature P7 ■ Frequency converter temperature P11
Standby operation	<ul style="list-style-type: none"> ■ Extending the service life for the ball bearings ■ Cutting energy consumption 	Reducing the rotor's frequency through P24
Troubleshooting	Quick analysis of problems	Reading of error memories P171, P174 and P176: error code, speed, operating hours for error
Slow pressure control by changing the pumping speed	Dispensing with a flow controller	Changing the rotor frequency through parameter 24
Reducing the maximum motor current	Cost savings through smaller power supply units if peak loads can be reduced	With P139, motor current reduction factor
Starting the pump with a delay if several consumers are connected to the same PSU	Cost savings through smaller power supply units if peak loads can be reduced	With P36, delay
Frequency converter as a simple pressure gauge, since motor current is dependent on the vacuum conditions	Dispensing with pressure gauges	Monitor motor current P5; second function for "Normal Operation" relay: relay switches as soon as the motor current threshold is tripped. Adjust second function: P29 Set motor current thresh.: P27
Lowering the normal operation threshold	Normal operating mode is attained faster, processes can be started faster	Reduce frequency threshold through P25

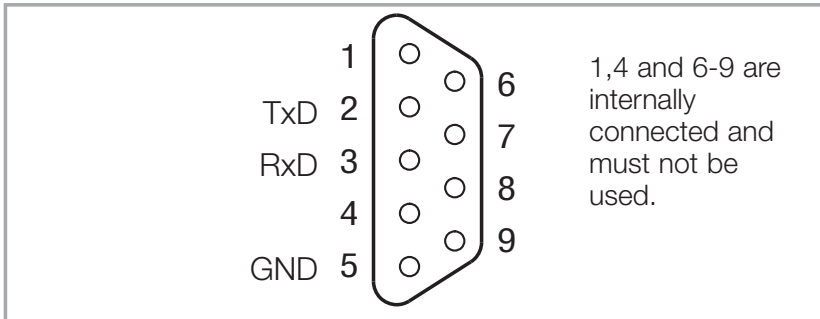

Fig. 3.1 Pin assignment for the socket at the frequency converter (female) SERVICE X5

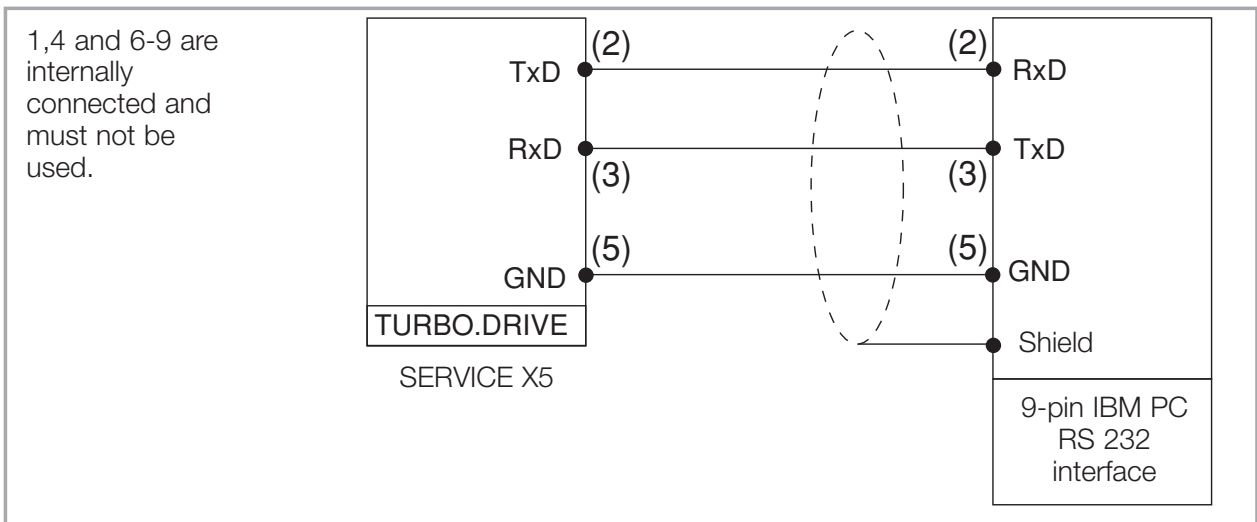

Fig. 3.2 Providing a RS 232 connection

Operation

3.2.1 RS 232 C interface (SERVICE X5)

Standards	DIN 66020
Protocol	acc. to VDI/VE 3689
Transmission rate	19200 baud
Response delay	default setting 10 ms (parameter 180)
Address range	non-addressable
Max. cable length	5 m
Interface connector	9 way Sub-D type, socket on the instrument (female) thread UNC4-40

Note: If on the controlling side an RS 232 interface in accordance with the PC standard with a 9-pin Sub-D male connector is present, then a straight through cable as shown in Fig. 3.2 may be used.

Refer also to Operating Instructions GA 05.281

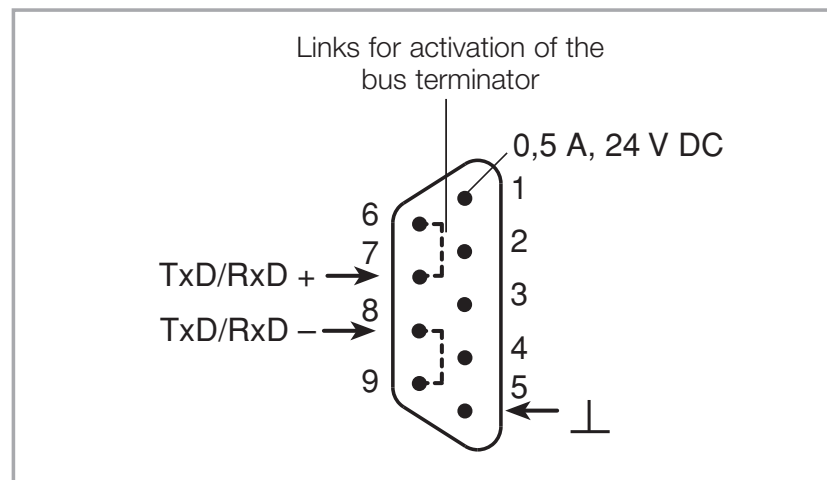

Fig. 3.3 Pin assignment for the socket at the frequency converter for RS 485 interface (male)

3.2.2 RS 485 interface

Standards	ISO/IEC 8482, EIA 485
Protocol	acc. to VDI/VDE 3689
Transmission rate	19200 baud fixed
Response delay	default setting 10 ms (parameter 180)
Address range	0 ... 15
Max. cable length	50 m (with bus termination)
Type of cable	2 wire twisted pair (twisted pair cable)
Differential voltage levels (see also "Standards")	logic "0": transmitter: 1.5 ... 5 V receiver: > 0.3 V logic "1": transmitter: - 1,5 ... - 5 V receiver: ≤ - 0,3 V
Interface connector	9 way Sub-D type, socket on the instrument (male) thread UNC4-40

Note: After having changed the bus address through the rotary switch (see Fig. 1.3), the frequency converter must be switched off (yellow power LED off) and then on again so as to enable the new address setting.

Bus addresses over 15 can only be set via Parameter 37.

Refer also to Operating Instructions GA 05.281

Operation

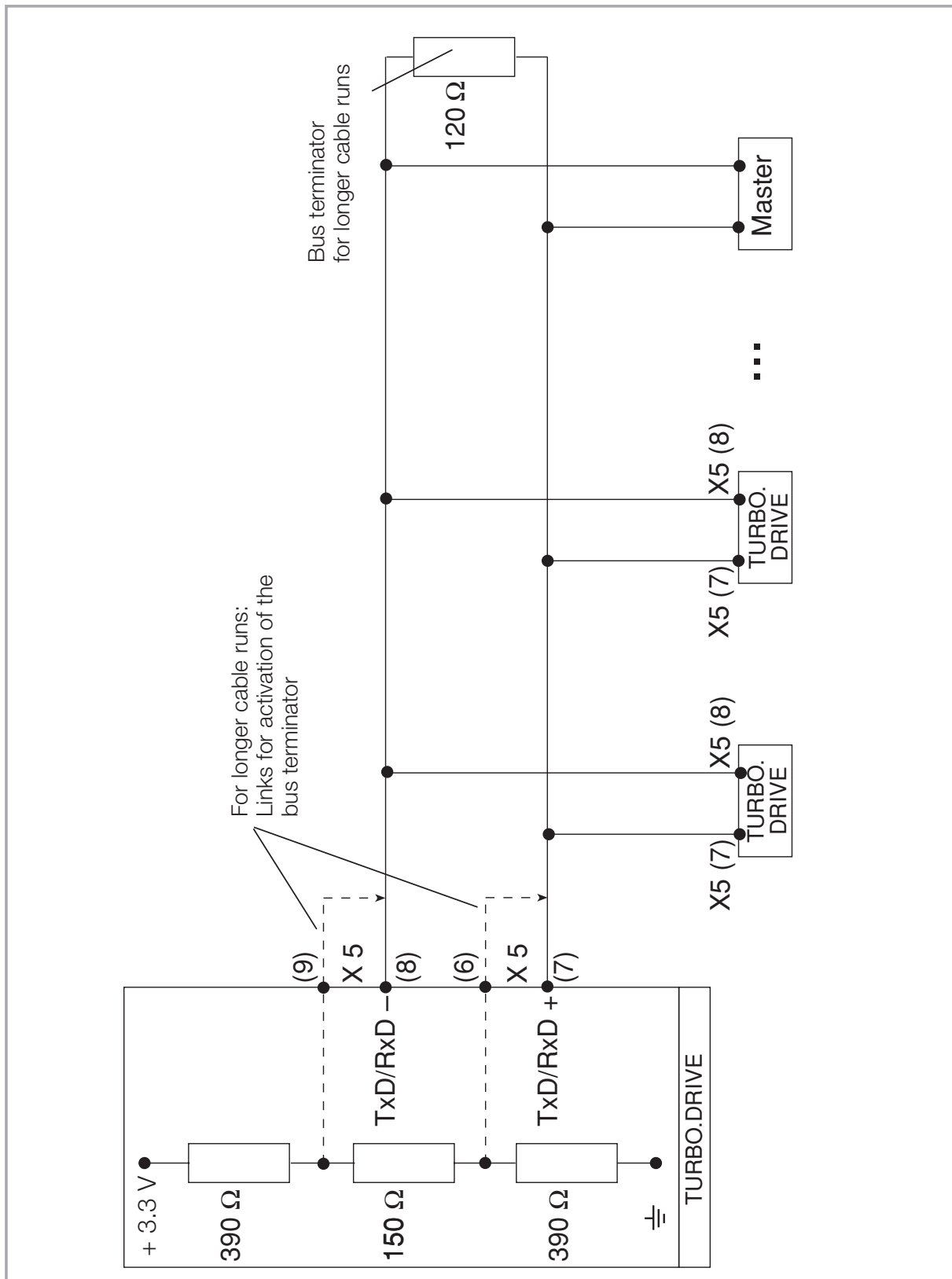

Fig. 3.4 Connection of the RS 485 bus

3.2.3 Profibus DP

The Profibus DP used has been defined in the standards EN 50170 and VDI/VDE 3689.

For more information on the Profibus system:

"The New Rapid Way to Profibus DP",
Manfred Popp, Profibus Nutzerorganisation e.V.,
Haid-und-Neu-Str. 7
76131 Karlsruhe, Germany
P/N: 4.072
www.profibus.com

Upon request we shall be pleased to provide detailed information on the hardware and the protocol used for the data.

Refer also to Operating Instructions GA 05.281

Operation

3.2.4 USB Interface (X106)

Transmission rate	19,200 Baud
Response delay time	10 ms (default) (parameter 180)
Address range	non-addressable
Maximum cable length	5 m
Interface connector	USB B

Notice: the USB interface has been electrically separated from the converter and is supplied from the side of the USB host with a current of approximately 15 mA. Via the protection diode, separation with respect to 33 V is maintained.

3.2.5 Parameter list

* specific values for each pump; see table of pumps, Chapter 3.2.6; r = readable, w = writable

No.	Designation	Min.	Max.	Default	Unit	r/w	Format	Description
1	Converter type	0	65535	0		r	u16	136 = Turbo.Drive 400
2	Software version	0	65535	10000		r	u32	xx.yy: version, zz: correction index
3	Actual frequency	0	65535	0	Hz	r	u16	Actual rotor frequency
4	Actual intermediate circuit voltage	0	1500	30	0,1 V	r	u16	Actual intermediate circuit voltage of the converter
5	Actual current	0	150	0	0,1 A	r	u16	Actual motor current
6	Actual electrical power	0	65535	0	0,1 W	r	u16	Actual drive input power
7	Actual motor temperature	-10	150	0	°C	r	i16	Actual value of the motor temperature.
8	Save data command	0	65535	0		/w	i16	A write command with any value saves temporary data into nonvolatile memory.
11	Actual converter temperature	-10	150	0	°C	r	i16	Actual heat sink temperature of the converter.
16	Motor temperature warning threshold	0	150	*	°C	r	i16	Exceeding the motor temperature warning threshold results in a warning.
17	Nominal motor current	5	60	*	0,1 A	r	u16	Maximum permissible motor current
18	Maximum frequency	750	1200	*	Hz	r	u16	Highest permissible frequency
19	Minimum frequency	0	1200	*	Hz	r	u16	Lowest permissible frequency
20	Critical frequency	0	1200	*	Hz	r	u16	Minimum frequency level. When the pump is accelerating this frequency must be reached within the maximum passing time (P183).
23	Pump type	0	255	*		r	u16	
24	Setpoint frequency	0	1200	*	Hz	r/w	u16	Setpoint of the rotor frequency
25	Normal operation	35	99	90	%	r/w	u16	Setpoint of the frequency dependent normal operation level

Operation

No.	Designation	Min.	Max.	Default	Unit	r/w	Format	Description
27	Current norm. oper.	5	60	20	0,1 A	r/w	u16	Motor current dependent normal operation level; ; If P29[0] = 1: Defines the normal operation level. Normal operation if P5 <= P27 Parameter cannot be changed during operation of the system
29	Relay function X1	0	8	0		r/w	u16	If required, special functions can be assigned to the normal operation and the error relay. Field 0
specifies the function for normal operation: 0 = Frequency dependent 1 = Motor current dependent 2 = Fieldbus controlled 3 = Trigger current bearing temperature (P122) 4 = Venting function (P247/P248) 5 = Pump at standstill (f < 3) 6 = Start command is present 7 = Ready for switch on (=STW Bit1) 8 = No mains power failure or no generator operation (P303 Bit 4 =1 = generator operation) Field 1 specifies the function for the error relay: 0 = Energised when an error is present 1 = Deenergised when an error is present 2 = Fieldbus controlled 3 = Venting function								
32	Max. run-up time	30	2000	720	s	r/w	u16	Max. permissible time during which the pump must attain the normal operation threshold (P24*P25) with the start signal present.
36	Start delay time	0	255	0	0,1 min	r/w	u16	Delays the start of the pump to allow leadtime for the fore vacuum pump for example.
38	Start counter	0	65535	0		r	u16	Increments each time when passing through the critical speed range.
37	RS485 address	0	31	0		r/w	u16	Parameterizable RS485 address; The address is specified either through the address switch or a value entered here provided the address switch is set to 0. A change of this parameter setting will only be effective after the power supply has been switched off and on.
119	Bearing run-in function	0	1	0		r/w	u16	0=deactivated 1=new pump type starts with run-in sequence Run in using the run-in sequence specified through the pump table without run-up time monitoring (a min at b Hzc min at d Hz...in total 4 stages for mechanical pumps)

No.	Designation	Min.	Max.	Default	Unit	r/w	Format	Description
122	Normal TMS	20	70	40	°C	r/w	u16	Switch-on temperature for fan when P29[0]=3. For P125 > P122 the normal operation relay is energised.
125	Bearing temperature	-10	150	0	°C	r	i16	Actual value of the bearing temperature
126	Bearing temperature warning threshold	-10	150	*	°C	r	i16	Exceeding the bearing temperature warning threshold results in a warning
127	Bearing temperature	-10	150	0	°C	r	i16	Actual value of the bearing temperature
128	Motor temperature lower warning threshold	-10	150	2	°C	r	i16	Falling below the motor temperature lower warning threshold results in a warning.
131	Motor temperature lower error threshold	10	150	-10	°C	r	i16	Falling below the motor temperature lower error threshold causes the pump to be switched off.
132	Bearing temperature error threshold	-10	150	*	°C	r	i16	Exceeding the bearing temperature error threshold causes the pump to be switched off.
133	Motor temperature error threshold	-10	150	*	°C	r	i16	Exceeding the motor temperature error threshold causes the pump to be switched off.
134	Enable cooling fan on turbopump	0	19	19		r/w	116	0 = Cooling fan off 19 = Cooling fan on
139	Current reduction factor	30	100	100	%	r/w	u16	Is used for the reduction of the maximum consumption current, e.g. for adaptation of low performance power supplies. Note: values < 100 reduce the pump performance and increase the run-up time.
140	Intermediate circuit current	0	150	0	0,1 A	r	i16	Actual average intermediate circuit current of the converter.
150	Standby frequency	0	1200	*	Hz	r/w	u16	Standby operation frequency setpoint
151	Enable standby	0	1	0		r/w	u16	0 = normal speed (P24); 1 = standby speed (P150)

Operation

No.	Designation	Min.	Max.	Default	Unit	r/w	Format	Description
171	Error code memory	0	65535	0		r	u16	Indexed parameter for storing the most recent 40 error codes. The individual error memory entries are accessed via this parameter with additional index number. The last error code is accessed with index 0 and the oldest with index 39. See Section 5 Troubleshooting for the error codes.
174	Error rotor frequency	0	65535	0	Hz	r	u16	Actual speed, when error occurred. Access analogously as for parameter 171.
176	Error operating hours	0	2147483647	0	h	r	u32	Operating hours, when error occurred. Access analogously as for parameter 171.
179	Fallback PZD1	0	65535	1024		r/w	u16	Response when cancelling the control rights or in the case of a communication interruption of the bus adapter Behaviour in case bit 10 in the control word of the bus adapter is cancelled or when interrupting the communication between converter and bus adapter (see also P182). Here it is assumed that the respective bus adapters perform a cyclic communication on the USS side, so that the respective converter electronics is capable of detecting a communication interruption The bits in parameter 179 represent an equivalent to the control word in the USS protocol. The actions linked to these bits are run provided bit 10 in the control word (USS protocol for bus adapter) is cancelled or if there are interruptions in the communication between converter and bus adapter. Here bit 10 is of special significance: Bit 10 = 0 The control rights are returned to the next lower priority level. All other bits are not relevant. Bit 10 = 1 The control rights remain unchanged. The actions linked to the other bits are run.
180	Resp. delay time	0	20	10	ms	r/w	u16	Response delay time; Pause time between received and transmitted USS protocol string of the frequency converter's serial interface RS232 and RS485. We recommend not to change the default setting (10ms).
182	Watchdog timer USS	0	65535	10	0,1 s	r/w	u16	Delay when cancelling the control rights of the bus adapter and time-out in the case of a communication interruption Defines the time characteristic when cancelling bit 10 in the control word of the USS protocol or when an interruption in the communication between bus adapter and converter and electronics is detected. Handling when cancelling bit 10 or when there is an interruption on the communication side of the USS bus adapter, is the same. Value 0.0: Indefinite time delay. In this way a change of the control right is inhibited. Values 0.1 ..6553.5: A change in the control right corresponding to the setting of parameter 179 is only effected after the time span defined through parameter 182 has elapsed.

No.	Designation	Min.	Max.	Default	Unit	r/w	Format	Description
183	Max. passing time	0	1800	500	s	r	u16	Max. permissible time during which the pump must - with the start signal present - have passed through the critical speed range between 60 Hz and P20.
184	Converter operating hours	0	2147483647	0	0,01 h	r	u32	Counts the operating hours of the converter during active pump operation.
227	Warning bits 1	0	65535	0		r	u16	Active warnings described bit per bit. See Section 3.2.6.
247	Vent on frequency	0	1200	300	Hz	r/w	u16	Frequency at which the venting valve shall be switched on in the event of a mains power failure. Power failure venting can be enabled through P240.
248	Vent off frequency	0	1200	5	Hz	r/w	u16	Frequency at which the venting valve shall be switched off in the event of a mains power failure. Power failure venting can be enabled through P240.
249	Generator operation	0	1	1		r/w	u16	0 = inactive 1 = active
303	Actual operating status	0	65535	0		r	u16	Bit 0: Normal operation Bit 1: Ready for switch on Bit 2: Speed is increasing Bit 3: Speed is dropping Bit 4: Generator operation Bit 5: Standby Bit 6: reserved Bit 7: reserved

Operation

No.	Designation	Min.	Max.	Default	Unit	r/w	Format	Description
312	Catalog number of converter	0	127		:CHAR [8000xxV000x]	r	u16	Catalogue number of the converter. One ASCII char per index.
313	Product name (Index 0...10 usable)	0 0	127 127	[TD_400]	:CHAR :CHAR	r r	u16 u16	Product name of the converter. One ASCII char per index. Only for DeviceNet purpose
315	Serial number of converter (Index 0...10 usable)	0	127		:CHAR [xxxxxxxxxxx]	r	u16	Serial number of the converter. One ASCII char per index.
918	Act. Profibus addr.	0	65535	0		r	u16	Active Profibus address
947	Current error number	0	65535	0		r	u16	Currently pending error. See Chapter 5 Troubleshooting.

3.2.6 Specific parameter data for the pumps

Type of pump	Pump designation	Nominal and setpoint frequency	Minimum setpoint frequency	Minimum frequency level	Max. motor current	Max. bearing temp.	Max. motor temp.	Bearing temp. warning threshold	Motor temp. warning threshold
P23		P18 / P24	P19	P20	P17	P132	P133	P126	P16
0	TW 220/150 TW 220/150/15	750	650	375	6.0	80	100	70	95
1	TW 400/300/25S TW 250/200/40	800	650	375	6,0	80	100	70	95
2	TW 250S	860	750	340	5.0	67	100	60	95
3	TW 70 H	1200	910	340	5.0	67	90	60	85
4	TW 290 H / TW 300 / TW 300 H	1000	890	375	5.0	80	63	70	58
5	SL 80	1200	910	340	5.0	–	55	–	53
6	SL 300	1000	890	375	5.0	–	56	–	54

Type of pump P23	Pump designation	Standby frequency [Hz] P150
0	TW 220/150 TW 220/150/15	700
1	TW 400/300/25S TW 250/200/40	700
2	TW 250S	800
3	TW 70 H	910
4	TW 290 H / TW 300 / TW 300 H	960
5	SL 80	910
6	SL 300	960

Run-in sequence, bearing run-in function

Type of pump P23	Pump designation	Run-in speed 1 [Hz]	Run-in time 1 [s]	Run-in speed 2 [Hz]	Run-in time 2 [s]	Run-in speed 3 [Hz]	Run-in time 3 [s]
0	TW 220/150 TW 220/150/15	100	3600	300	5400	300	5400
1	TW 400/300/25S TW 250/200/40	100	3600	300	5400	300	5400
2	TW 250S	100	3600	300	5400	500	5400
3	TW 70 H	180	3600	350	5400	600	5400
4	TW 290 H / TW 300 / TW 300 H	200	3600	430	5400	580	5400
5	SL 80	180	3600	430	5400	580	5400
6	SL 300	200	3600	430	5400	580	5400

Operation

3.2.7 Warning codes for parameter 227

P227, Bit	Designation	Meaning	Possible cause	Remedy			
0	Motor temperature warning	The motor temperature has passed the warning threshold	Forevacuum pressure too high.	Check the ultimate pressure of the backing pump and install a bigger backing pump if req.			
			Gas flow too high	Seal leak, check process			
			Fan defective	Replace fan			
			Water cooling switched off	Switch on water cooling			
			1	Converter temperature warning	Overtemperature at the power output stage or within the frequency converter	Ambient temperature too high Poor cooling	Ensure max. ambient temperature of 45°C Improve cooling
			2	Bearing over-temperature warning	The permissible warning threshold for the bearing temperature was exceeded.	Forevacuum pressure too high.	Check the ultimate pressure of the backing pump and install a bigger backing pump if req.
Gas flow too high	Seal leak, check process						
Fan defective	Replace fan						
			Water cooling switched off	Switch on water cooling			
			3	Motor under-temperature warning	The minimum permissible motor temperature (warning threshold) is not reached.	Ambient temperature too low	Ensure min. ambient temperature of 0°C
						Pump cooling too high	Reduce water cooling
4, 5	not used						
6	Overspeed warning						

P227, Bit	Designation	Meaning	Possible cause	Remedy
7, 8, 9, 10	not used			
11	Overload warning	The pump speed has dropped under the normal operation threshold	Forevacuum pressure too high. Gas flow too high	Check the ultimate pressure of the backing pump and install a bigger backing pump if req. Seal leak, check process
12, 13	not used			
14	Power supply voltage warning	Supply voltage failure during active operation of the pump $P4 > U_{max}$ or $P4 < U_{min}$	Intermediate circuit voltage too low or maximum time for generator operation was exceeded. DC power supply voltage below 24V Mains voltage failure	
15	Fan voltage has failed			

Operation

3.3 Switching on

Switch on the DC power supply. The yellow LED at the frequency converter lights up.

Switch on the turbomolecular pump at the frequency converter

- via pins 7 and 8 of the socket REMOTE (X1) (For example via a remote control or with the aid of the plug with integrated ON/OFF switch: see Section 1.5 Accessories).
- by a start command via the interface.

The turbomolecular pump accelerates. The green LED flashes. When the pump reaches normal operation the green LED lights up permanently.

After a mains power failure the pump can run up automatically once more.

3.4 Shutting down

Switch off the pump at the frequency converter.

- via contacts 7 and 8 of the socket REMOTE (X1).
- apply a stop command via the interface.
- for the power supply units offered or recommended by Oerlikon Leybold Vacuum switch off the DC voltage.

After switching off, the green status LED will flash until the rotor of the turbomolecular pump is at standstill. This may take several minutes. With the DC power supply off, the turbomolecular pump will act as a generator supplying the frequency converter with energy as indicated by the yellow power LED.

If a failure occurs the turbomolecular pump will be shut down automatically. The red LED at the frequency converter lights up.

To shut down the frequency converter, switch the pump off and wait until the rotor of the turbomolecular pump has arrived at standstill (green status LED off).

Then switch the mains power off and wait until the yellow power LED is off. Then only disconnect any cable connections.

3.5 Emergency shut down

The emergency shutdown facility of a system controller must be capable of shutting the pump down as detailed in Chapter 3.3. The rotor of the turbomolecular pump may be stopped faster by venting the pump; for this refer to the Operating Instructions for the pump.

3.6 Setting pumping speed and rotational speed

For the purpose of reducing the pumping speed of the pump because of application requirements or for other reasons it can make sense to reduce the rotational speed.

In order to permanently reduce the speed we recommend the following procedure:

With the aid of a Windows PC and the PC software "TURBO.DRIVE Server" change the setting for the parameter 24 "Setpoint frequency". The possible values for parameter 24 will depend on the type of pump connected. Parameter 18 "Nominal pump frequency" defines the maximum value and parameter 19 "Minimum setpoint frequency for the pump" defines the minimum value.

So as to retain the value saved for parameter 24 when switching the pump off, the parameter value needs to be saved permanently. For this enter any value (for example 1) for parameter 8. Thereafter changed parameters will be saved permanently.

Parameters which are typical for the specific type of pump (see Chapter 3.2.5) are reset to the factory defaults after having changed the type of pump and when switching on the power supply voltage again.

The rotational speed of the pump may be changed during operation also with the aid of a Windows PC and the PC software "TURBO.DRIVE Server".

However, we here recommend a PLC compliant solution with the aid of the Profibus. The speed can be set over the Profibus in two ways:

- by changing parameter 24 within the limits defined by parameters 19 and 18 or
- by transfer as the main setpoint (for this also refer to VDI/VDE 3689).

3.7 Operation at reduced current

Not all applications require that the TURBO.DRIVE 400 be operated at its maximum current. Operation at reduced current will allow operation off a smaller power supply unit or to operate two or more turbomolecular pumps off a power supply unit which in practice is just not strong enough to supply the maximum current for several connected pumps. However, this will increase the run up time, and the maximum gas throughput and backing pressure specifications are reduced.

For this proceed as follows:

With the aid of a Windows PC and the PC software "TURBO. DRIVE Server" change the setting for the parameter 139 "Current reduction factor". The possible values for parameter 139 can be varied within the limits of 30 to 100 % of parameter 17 (current depends on the type of connected pump). The newly entered current reduction factor will only be active after switching off and on again.

So as to retain the value saved for parameter 139 when switching the pump off, the parameter value needs to be saved permanently. For this enter any value (for example 1) for parameter 8. Thereafter changed parameters will be saved permanently.

3.8 Changing the frequency dependent normal operation level

Depending on the quality of the vacuum which needs to be provided by the turbomolecular pump it may make sense to reduce the frequency dependent normal operation threshold, so that the ready status can be attained faster by the vacuum system. The factory default of 90 % represents a good compromise so that a change will hardly ever be required.

For this proceed as follows:

With the aid of a Windows PC and the PC software "TURBO. DRIVE Server" change the setting for the parameter 25 "Frequency dependent normal operation level". The possible values for parameter 25 can be varied within the limits of 35 to 99 % of parameter 24 (nominal speed depends on the type of connected pump).

So as to retain the value saved for parameter 25 when switching the pump off, the parameter value needs to be saved permanently. For this enter any value (for example 1) for parameter 8. Thereafter changed parameters will be saved permanently.

3.9 Changing the maximum permissible run up time

In vacuum systems at a high backing pressure or with increased quantities of gas during the run up phase, the run up time for the turbomolecular pump may be longer. This will then cause the frequency converter to output an error message,

The maximum permissible run up time is changed as follows:

With the aid of a Windows PC and the PC software "TURBO. DRIVE Server" change the setting for the parameter 32 "Maximum run up time". The possible values for parameter 32 can be varied within the limits of P183 to 2000 seconds. The default setting is 720 seconds. As a rule, no value below 720 seconds should be entered as this would give rise to unnecessary error messages. If a significantly higher value than 720 seconds is required, this may indicate that the turbomolecular pump is being overloaded. For this reason in such a case the temperature data from the frequency converter and the turbomolecular pump (parameter 7 = motor temperature, 11 = frequency converter temperature, 125/127 bearing temperature) should be specially monitored during application trials.

So as to retain the value saved for parameter 32 when switching the pump off, the parameter value needs to be saved permanently. For this enter any value (for example 1) for parameter 8. Thereafter changed parameters will be saved permanently.

Operation

3.10 Changing the start delay time

Generally it will make sense to let the turbomolecular pump run up immediately after applying the start command. However when operating two or more turbomolecular pumps off a single power supply unit, it may make sense to start the pumps one after the other. One way of achieving this is to enter a start delay time differing from 0.

To set up the start delay time proceed as follows:

With the aid of a Windows PC and the PC software "TURBO. DRIVE Server" change the setting for the parameter 36 "Start delay time". The possible values for parameter 36 can be varied within the limits of 0 to 25.5 minutes (0 to 255).

So as to retain the value saved for parameter 36 when switching the pump off, the parameter value needs to be saved permanently. For this enter any value (for example 1) for parameter 8. Thereafter changed parameters will be saved permanently.

3.11 Selecting relay functions

See parameter 29.

3.12 Reading the error memory

The TURBO.DRIVE 400 is capable of permanently saving up to 40 error events. The error codes are saved under parameter number 171. In addition to each error code the following is also saved:

- Rotor frequency at the point of time when the error event in parameter 174 occurred.
- The corresponding number of operating hours in parameter 176.

Access to each of the 40 groups of values is accomplished with the aid of an index value which needs to be stated besides the parameter number when accessing via the protocol in accordance with VDI / VDE 3689. The range of index numbers ranges from 0 to 39.

Maintenance

4 Maintenance

The frequency converter is maintenance free. Repairs must only be done by Oerlikon Leybold Vacuum.

If required clean the frequency converter of dust with a dry cloth.

When removing a defective frequency converter from an installation, please note the information given in Chapter 3.4.

During all work on the pump which is being driven by the frequency converter, the system must be protected against being switched on. For this disconnect the DC power supply.

5 Troubleshooting

Before you start searching for the source of the problem, you should carry out a few simple checks:

Are the connections in good working order?

- Mains connection,
- DC power supply to the frequency converter,
- Connector cable between the frequency converter and the pump

Is the forevacuum pressure sufficient?

After having removed the cause for the error reset the error message at the TURBO.DRIVE:

- In case of error code 8 by switching the mains power off.
- In case of the other errors by applying a STOP signal via the socket REMOTE (X1) or a reset sequence via the serial interface or by switching the mains power off.

The error codes can only be read if a serial interface is present.

The following table has been provided as a guide when determining the causes of errors.

Troubleshooting

Error code	Designation	Meaning	Possible Cause	Remedy	Shut-down
1	Overspeed warning	The actual frequency exceeds the setpoint by over 10 Hz.	Frequency converter defective	Contact Oerlikon Leybold Vacuum Service.	no
2	Pass through time error	The pump has not reached the minimum speed after the maximum run-up time has elapsed.	Forevacuum pressure too high. Gas flow too high Rotor blocked	Check the ultimate pressure of the backing pump and install a bigger backing pump if req. Seal leak, check process Check if the rotor turns freely. Contact Oerlikon Leybold Vacuum Service if the rotor is damaged or blocked.	yes
3	Bearing temperature error	The maximum permissible bearing temperature was exceeded.	Forevacuum pressure too high. Gas flow too high Fan defective Water cooling switched off	Check the ultimate pressure of the backing pump and install a bigger backing pump if req. Seal leak, check process Replace fan Switch on water cooling	yes
4	Short circuit error				yes
5	Converter temperature error	Overtemperature at the power output stage or within the frequency converter	Ambient temperature too high Poor cooling	Ensure max. ambient temperature of 45°C Improve cooling	yes

Troubleshooting

Error code	Designation	Meaning	Possible Cause	Remedy	Shut-down
6	Run-up time error	The pump has not reached the normal operating frequency after the maximum run-up time.	Forevacuum pressure too high.	Check the ultimate pressure of the backing pump and install a bigger backing pump if req.	yes
			Gas flow too high	Seal leak, check process	
7	Motor temperature error	The motor temperature has exceeded the shutdown threshold.	Forevacuum pressure too high.	Check the ultimate pressure of the backing pump and install a bigger backing pump if req.	yes
			Gas flow too high	Seal leak, check process	
			Fan defective	Replace fan	
			Water cooling switched off	Switch on water cooling	
8	Pump error	Pump couldn't be identified or no pump is connected	Pump not connected correctly to frequency converter	Check connection between pump and frequency converter	yes
			Hardware defective	Contact Oerlikon Leybold Vacuum Service	
61	Bearing temperature warning, top				no
82	Fan voltage has failed				no
83	Motor temperature low warning				no

Troubleshooting

Error code	Designation	Meaning	Possible Cause	Remedy	Shut-down
84	Motor over-temperature warning				no
101	overload warning	The pump speed has dropped under the normal operation threshold	Forevacuum pressure too high. Gas flow too high	Check the ultimate pressure of the backing pump and install a bigger backing pump if req. Seal leak, check process	no
103	Supply voltage warning	Intermediate circuit voltage too low or maximum time for generator operation was exceeded.	DC supply voltage below 24V Mains voltage has failed	Check the voltage at the power supply and if required set up correctly Remedy the cause for the mains power failure	no
106	overload error	The pump speed has dropped under the minimum speed	Forevacuum pressure too high. Gas flow too high	Check the ultimate pressure of the backing pump and install a bigger backing pump if req. Seal leak, check process	yes
111	Motor under-temperature error	The minimum permissible motor temperature is not attained.	Ambient temperature too low Pump cooling too high	Ensure min. ambient temperature of 0°C Reduce water cooling	yes

Troubleshooting

Error code	Designation	Meaning	Possible Cause	Remedy	Shut-down
116	Permanent overload error	The speed of the pump has dropped below the normal operation threshold and has stayed there for a longer period of time.	Forevacuum pressure too high. Gas flow too high	Check the ultimate pressure of the backing pump and install a bigger backing pump if req. Seal leak, check process	yes
117	Motor current error	Motor current less than nominal current	Cable fault Faulty connector	Contact Oerlikon Leybold Vacuum Service	yes
126	Bearing temperature sensor error top	Bearing temperature sensor defective	Sensor defective, short circuit or broken cable	Contact Oerlikon Leybold Vacuum Service	yes
128	Motor temperature sensor error	Motor temperature sensor defective	Sensor defective, short circuit or broken cable	Contact Oerlikon Leybold Vacuum Service	yes
143	Overspeed error				yes

Troubleshooting

Error code	Error	Possible Cause	Remedy	Shut-down
–	Yellow power LED is not on	No DC power DC power miswired Frequency converter defective	Check cables and power supply Ensure correct polarity of the DC cable. Replace frequency converter. The following may damage the freq. converter: <ul style="list-style-type: none"> ■ Disconnection of the DC cable while the pump was still rotating ■ Non-compliance with the note related to connecting several pump to a single power supply. 	–
div.	Red LED flashes	Warning message. See Section “3.2.6 Warning codes” for the possible reasons of the warning.	The pump can continue to run, as long as operation limits are only exceeded for a short time. In case of longer exceeding send pump and frequency converter to the OLV service.	no

Troubleshooting

Error code	Error	Possible Cause	Remedy	Shut-down
–	Turbomolecular pump does not start, ERROR LED does not light.	Interface protocol error No communication via the serial interface. REMOTE connector (X1) connected wrongly. REMOTE and SERVICE connectors mixed up. Wrong Profibus address set.	Use USS protocol. Connect bus as shown in Section 3.2. Connect as shown in Fig. 2.6 Connect correctly. Set address between 0 and 126.	–
–	Turbomolecular pump produces loud running noises and vibrations.	Rotor out of balance Bearing defective	Balance the rotor Replace the bearing	no

Troubleshooting

Error code	Error	Possible Cause	Remedy	Shut-down
-	Turbomolecular pump does not reach ultimate pressure.	<p>Measurement instrument defective</p> <p>Measurement sensors soiled</p> <p>Leaks at the equipment, lines or the pump</p> <p>Pump soiled</p> <p>Forevacuum pump provides insufficient pumping speed or ultimate pressure which is too high.</p> <p>Frequency parameters programmed wrongly</p>	<p>Inspect the measurement sensor</p> <p>Clean or replace the sensors</p> <p>Check for leaks</p> <p>Clean the pump</p> <p>Check the ultimate pressure of the forevacuum pump and install a higher-capacity vacuum pump if necessary</p> <p>Check parameters.</p>	no
-	Running pump can not be stopped via X1	Pump has been started via the serial interface, the interface controls the pump	Disconnect the DC supply or connect serial interface and stop via bus	no

Waste Disposal

6 Waste Disposal

The equipment may have been contaminated by the process or by environmental influences. In this case the equipment must be decontaminated in accordance with the relevant regulations. We offer this service at fixed prices. Further details are available on request.

Contaminated parts can be detrimental to health and environment. Before beginning with any work, first find out whether any parts are contaminated. Adhere to the relevant regulations and take the necessary precautions when handling contaminated parts.

Separate clean components according to their materials, and dispose of these accordingly. We offer this service. Further details are available on request.

This product complies with the European Community Regulation 2002/95 (RoHS Restriction of Hazardous Substances).

Contamination

CAUTION



RoHS compliance

EC Declaration of Conformity

The manufacturer: Oerlikon Leybold Vacuum GmbH
Bonner Strasse 498
D-50968 Cologne, Germany
Tel.: +49 (0)221 347-0
info.vacuum@oerlikon.com

herewith declares that the products specified and listed below which we have placed on the market, comply with the applicable EC Council Directives. This declaration becomes invalid if modifications are made to the product without agreement of Oerlikon Leybold Vacuum GmbH. Compliance with the EMC Directives requires that the components are installed within a system or machine in a manner adapted to EMC requirements.

Product designation: Frequency converter
Type designation: TD400
Catalogue No.: 800073V0002 /03 /04 /05 /06 /07 /08

The product complies to the following European Council Directives:

- Directive on Low Voltage (2006/95/EC)
- Directive on Electromagnetic Compatibility (2004/108/EC)

The following harmonised standard has been applied:

- EN 61010-1 2001 incl correction 1 (11/2002) and correction 2 (1/2004)

Störaussendung / Festigkeit

- EN 55011 2007; class B
- EN 55011 2009-A1:2010; class B
- EN 61326-1 2006-05 class B
- EN 61000-6-3 2007 class B
- EN 61000-6-2 2005

Documentation Officer:

Herbert Etges
Tel.: +49(0)221 347-0
Fax: + 49(0)221 347-1250
E-Mail. documentation.vacuum@oerlikon.com
Oerlikon Leybold Vacuum GmbH
Bonner Strasse 498, D-50968 Cologne, Germany

Cologne, dated 2011-4-8

Cologne, dated 2011-4-8



Dr. Monika Mattern-Klosson
Head of Research & Development



Harald Udelhoven
Head of Quality Management

oerlikon
leybold vacuum

www.oerlikon.com

LV_11139_2011 04.11

Oerlikon
Leybold Vacuum GmbH
Bonner Strasse 498
D-50968 Cologne
Phone: +49-(0)221-347 0
Fax: +49-(0)221-347 1250
info.vacuum@oerlikon.com