



# **Multi Variable Air Conditioners Cassette Type Indoor Unit Owner's Manual**

This instruction is suitable for the following model:

TGS-28FWCA

TGS-36FWCA

TGS-45FWCA

TGS-50FWCA

TGS-56FWCA

TGS-63FWCA

TGS-71FWCA

TGS-80FWCA

TGS-90FWCA

TGS-100FWCA

TGS-112FWCA

TGS-125FWCA

TGS-140FWCA



Please read this instruction carefully before operating  
 Thank you for your selecting of TOYOTOMI air conditioner, please read this usage  
 and install instruction carefully and keep it well in order to use this unit correctly.

Contents	USER NOTICES		1	
	Safety information		3	
	Install the cassette type indoor unit		4	
	Constitutes and Names of Parts of Cassette Type Indoor Unit		14	
	Working Temperature Range		14	
	Wired Remote Controller Operation Procedure	The components of the wired remote control		15
		ON/OFF operation		15
		Timer setting		16
		SLEEP mode setting		17
		Swing Control		17
		Fan Speed Control		17
		Temp. adjusting		18
		Set of running mode		18
		Malfunction display		18
	Remote controller operation procedure	Names and functions of every button of the remote control		20
		Names and functions of every button of the remote control (Remove the cover)		21
		Operation procedure		22
		How to insert batteries		22
	Operation Method When Meeting An Emergency		23	
	Malfunction Debarring		24	
Maintenance Method		26		
Model and Technical Parameter		29		



# USER NOTICES

- ☆ **When operating, the entire capacity of the cooperating indoor unit should be not larger than that of outdoor unit. Otherwise, it will cause the shortage of cooling (heating) capacity.**
- ☆ **A Breaker(or fuse) need to be installed in every indoor unit, and the capacity should in according with indoor unit's electrical parameter; all the indoor units are required to be centralized controlled by a total Switch, this Switch can cut off the electric power supply in case of emergency. The Breaker(or fuse) on each indoor units have the function of short circuit prevention and abnormal overload avoiding, it should be connected in normal situation. The total switch controlling the power supply of all the indoor units. Before clearing and maintenance job being carried out to the indoor units, it is very important to turn off the total power supply switch.**
- ☆ **In order to turn on the units successfully, the main power switch should be opened 8 hours before the operation.**
- ☆ **After receiving the turn off signal, every indoor unit will continue to work for 20-70sec to make use of the rest cool air or the rest heat air in the heat exchanger, while preparing for the next operation. And this is normal.**
- ☆ **When the selected operating mode of the indoor unit are clash with the operating mode of the outdoor unit, the malfunction light will blink after 5s on the indoor unit or remote controller showing that the operation clash, then the indoor unit will stop. At this time, change the operation mode of the indoor unit to the one that would not clash with the outdoor operating mode to make the operation normal. The cooling mode is not clash with the dry mode, while the fan mode is not clash with any mode.**
- ☆ **The appliance shall not be installed in the laundry**
- ☆ **An all-pole disconnection switch having a contact separation of at least 3mm in all poles should be connected in fixed wiring**
- ☆ **Missing information regarding electric supply tolerances( $\pm 10\%$ ,  $\pm 1\text{Hz}$ ) in documentation**
- ☆ **Missing information regarding humidity (30-95%) in documentation**

- ☆ **Missing information regarding installation altitude (max 1000m) in documentation**
  
- ☆ **Information regarding transport/storage temperature (-25-55°C) is missing**
  
- ☆ **Main switch provided by end user: main switch handle should be black or gray, it can be locked in “OFF” position with padlock**
  
- ☆ **The main disconnection device should be explained in user manual and the height should be recommended at 0.6-1.7m. over current protection is required(EN 60947-3, EN 60947-2)**
  
- ☆ **The cooling range of the unit is the outdoor environment temp.18-43°C DB, the heating range of the unit( only for the heat pump type unit) is the outdoor environment temp. -16-15°C WB.**

# Safety information

---

Please read this manual carefully before use this unit, and operate it correctly according to the guide in this manual.

1. Please take specially note to the meaning of these two marks:



**Warning !:** This mark means that it may cause casualty or badly heart if the operation is incorrect.



**Note !:** This mark means that it may cause casualty or property loss if the operation is incorrect.



**Warning!**

- Do not adopt fuse with unsuitable capacity or adopt iron thread instead of fuse, otherwise malfunction or fire may happened.
- Cut down the main power switch immediately if malfunction (such as smell the burning odor etc.) happened.
- Maintain ventilation to prevent oxygen leakage in room.
- Don't insert finger or stick like things into discharge vent or outlet grill.
- Please make sure that the unit is installed in the place that can bear the weight of it adequately. If the place is not strong enough, the air conditioner may drop and cause casualty event.
- Don't spray or smear any oil paint or insecticide on the surface of unit, otherwise, fire may be leaded.
- Do not refit the conditioner. Please contact the agency or prefect ional personnel to repair or move the conditioner.



**Note! :**

- Please check and make sure that the cord, drainage pipe and tubes are connected in the correct way to prevent leakage of water, refrigerant, electric shock or fire.
- The main power must connectable to the earth in order to assure the conditioner earthing effectively and to prevent electric shock. Please don't connect the earthing line with the gas pipe, water pipe, lightening rod or the connecting line of telephone.
- The air conditioner should be turned off at least after 5 mins' operation; otherwise it would affect the duration of the unit.
- Don't let the children operate the air conditioner.
- Please don't operate the unit by wet hand.
- Please turn off the main power of the unit before cleaning the conditioner or change the filter.
- Please cut off the main power if the conditioner will be used for a long time.

# Install of the Cassette type indoor unit

## ● Schematic diagram of installation spaces

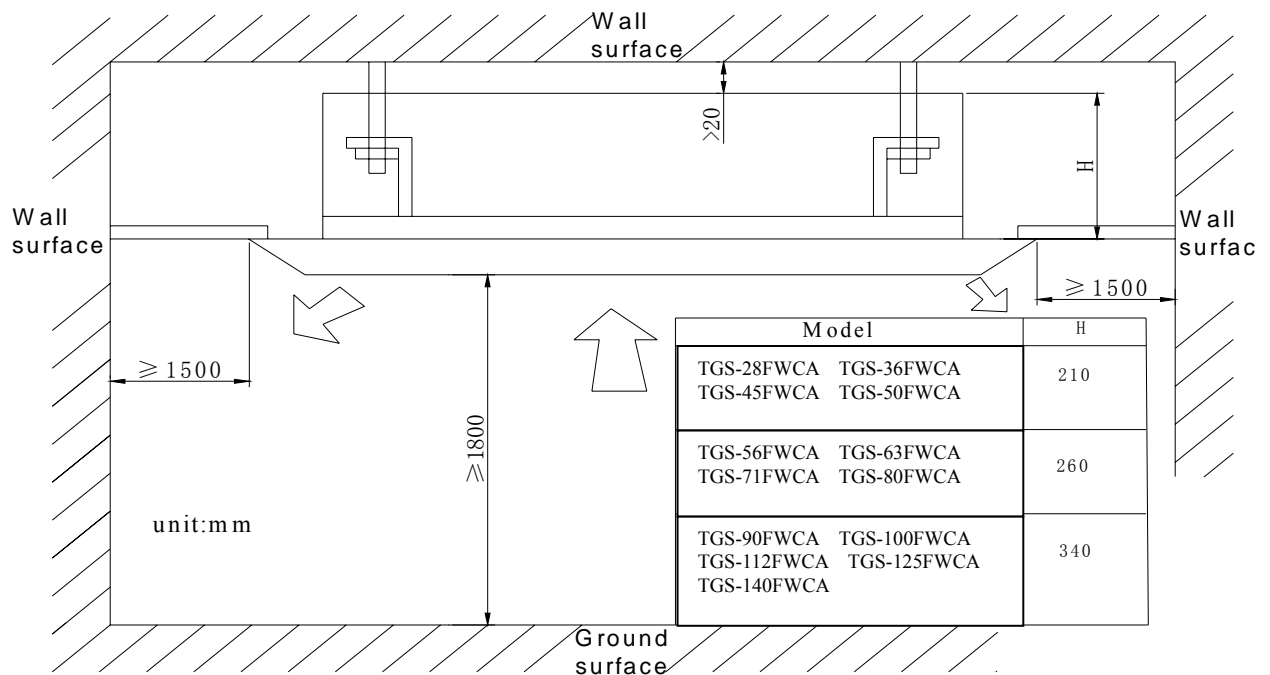

Fig.1

## ● Select install location of the indoor unit

1. Obstruct should put away from the intake or outlet vent of the indoor unit so that the airflow can be blown though all the room.
2. Make sure that the installation had accord with the requirement of the schematic diagram of installation spaces.
3. Select the place where can stand 4 times of the weight of the indoor unit and would not increase the operating noise and oscillate.
4. The horizontally of the installation place should be guaranteed.
5. Select the place where easy drain condensated coagulated water, and easy connect with outdoor unit.
6. Make sure that there are enough space for care and maintenance. Make sure that the weight between the indoor unit and ground is above 1800mm.
7. When installing the steeve bolt, check if the install place can stand the weight 4 times of the unit's. If not, reinforce before installation. (Refer to the install cardboard and find where should be reinforced)

### ⚠ Note!

There will be lots of lampblack and dust stick on the acentric, heat exchanger and water pump in dining room and kitchen, which would reduce the capacity of heat exchanger, lead water leakage and abnormal operation of the water pump. **The following treatment should be taken under this circumstance:**

1. Ensure that the smoke trap above cooker has enough capacity to obviate lampblack to prevent the indraft of the lampblack by the air conditioner.
2. Keep the air conditioner far from the kitchen so that the lampblack would not be indraft by the air conditioner.



# Install the cassette type indoor unit

## ● Important notice:

☆ To guarantee the good performance, the unit must be installed by professional personnel according with this instruction.

☆ Please contact the local TOYOTOMI special nominated repair department before installation. Any malfunction caused by the unit that is installed by the department that is not special nominated by TOYOTOMI would not deal with on time by the inconvenience of the business contact.

## ● Dimension of ceiling opening and location of the hoisting screw (M10)

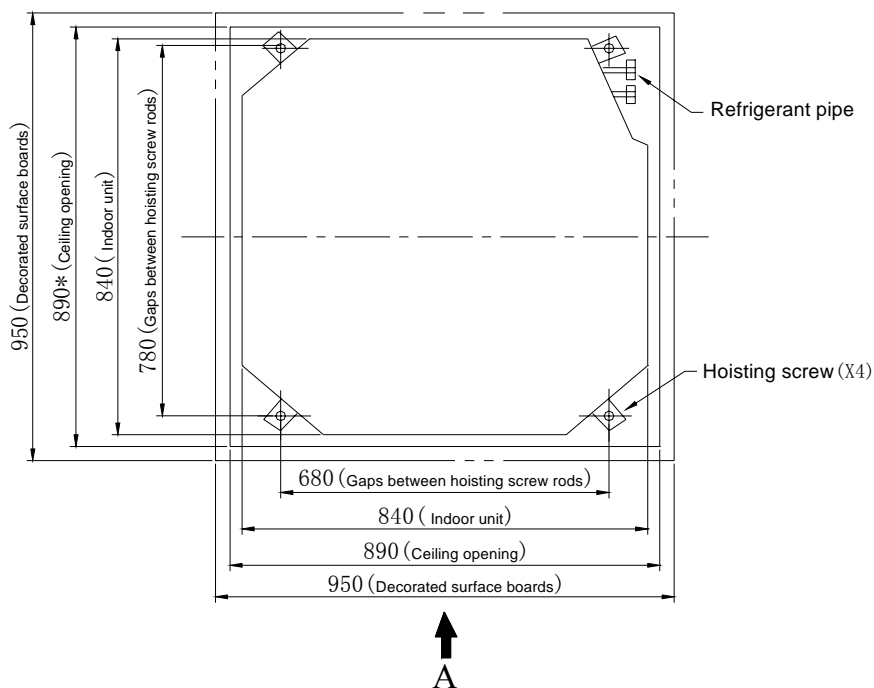

Install dimension of mode

TGS-28FWCA, TGS-36FWCA, TGS-45FWCA, TGS-50FWCA, TGS-56FWCA, TGS-63FWCA, TGS-71FWCA, TGS-80FWCA, TGS-90FWCA, TGS-100FWCA, TGS-112FWCA, TGS-125FWCA, TGS-140FWCA

☆ The drilling of holes in the ceiling must be done by the professional personnel.

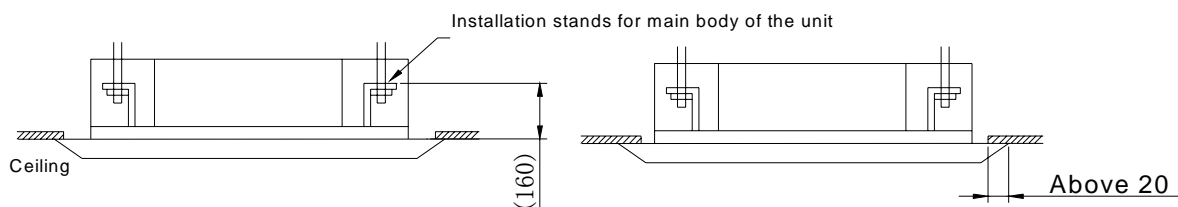

Fig.2

**Notes:** The dimension for the ceiling openings with \* marks can be as large as 910mm. But the overlapping sections of the ceiling and the decorated surface boards should be maintained at no less than 20mm.

# Install of the Cassette type indoor unit

## ● Main body of hoisting air conditioner

- 1 The primary step for install the indoor unit.
- ☆ When attach the hoisting stand on hoisting screw, do use nut and gasket individually at the upper and lower of the hoisting stand to fix it. The use of gasket anchor board can prevent gasket break off.
- 2 Use install cardboard
- ☆ Please refer to the install cardboard about the dimension of ceiling opening.
- ☆ The central mark of the ceiling opening is marked on the install cardboard.
- ☆ Install the install cardboard on the unit by bolt (3 piece), and fix the angle of the drainage pipe at the outlet vent by bolt.
- 3 Adjust the unit to the suitable install place. (Refer to the fig.2)
- 4 Check if the unit is horizontal.
- ☆ Inner drainage pump and bobber switch are included in the indoor unit, check if 4 angle of every unit are horizontal by water lever. (If the unit is slant toward the opposite of the coagulate water flow, there may be malfunction of the bobber switch and lead water drop.)
- 5 Backout the gasket anchor board used to prevent gasket break off and tighten the nut on it.
- 6 Backout the install cardboard.

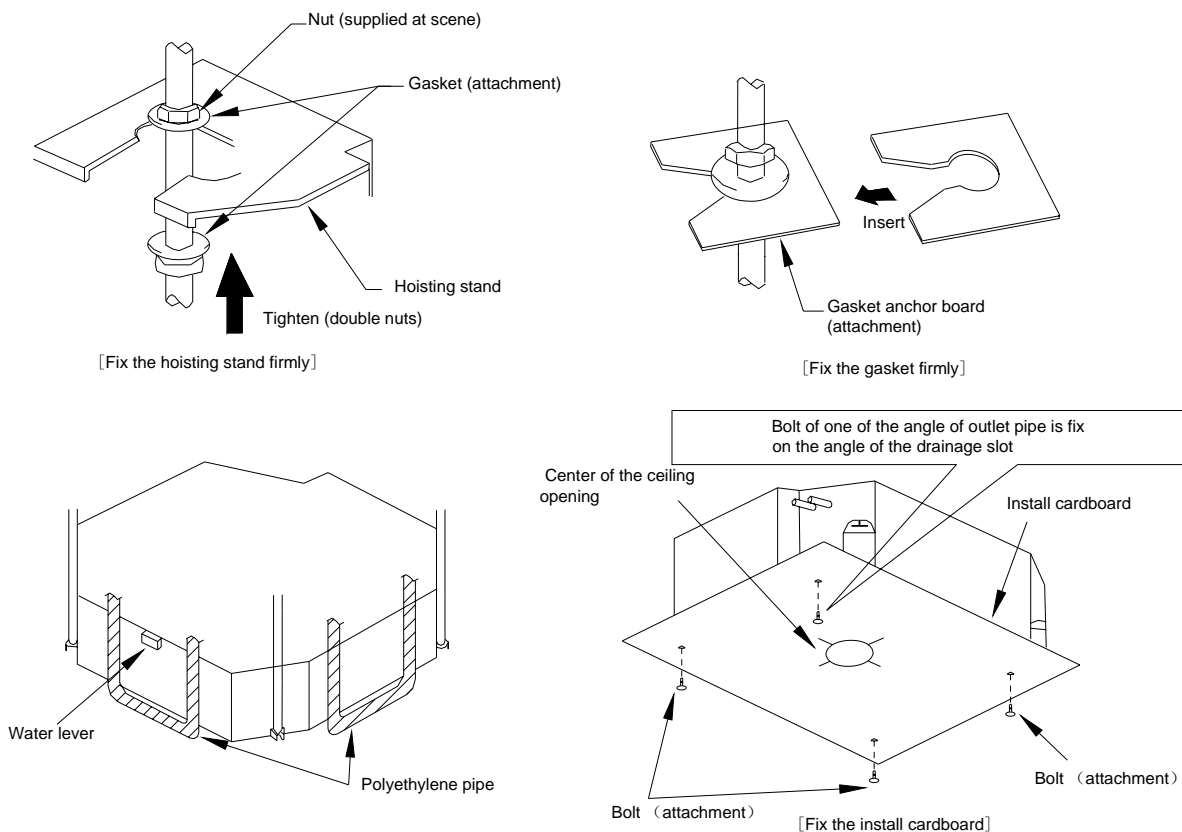

### ⚠ Note!

- Please do tighten the nuts and bolts to prevent air conditioner break off.

# Install of the Cassette type indoor unit

## ● Connect the refrigerant pipe

- ☆ When connect the pipe to the unit or backout it from the unit, please do use both spanner and torque wrench. as shown in fig.3.
- ☆ When connect, smear both inside and outside of the flare nut with freeze motor oil, screw it by hand and then tighten it with spanner.
- ☆ Refer to form 1 to check if the wrench had been tightened (too tight would mangle the nut and lead leakage).
- ☆ Examine the connection pipe to see if it had gas leakage, then take the treatment of heat insulation, as shown in the fig.3.
- ☆ Only use median sponge to entwine the wiring interface of the gas pipe and heat preservation sheath of the gas collection tube.

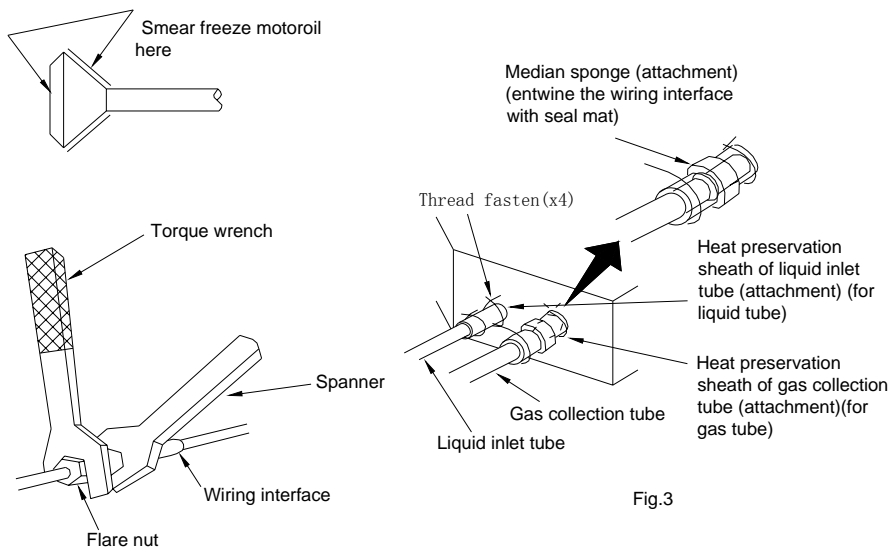

Fig.3

Form 1: The tightening torque needed for tightening nut

Diameter (Inch)	Surface thickness (mm)	Tightening torque (N.m)
φ 1/4"	≥0.5	15-30 (N • m)
φ 3/8"	≥0.71	30-40 (N • m)
φ 1/2"	≥1	45-50 (N • m)
φ 5/8"	≥1	60-65 (N • m)
φ 3/4"	≥1	70-75 (N • m)

## ● Drainage hose

### 1. Install the drain hose

- ☆ The diameter of the drain hose should be equal or bigger than the connection pipe's. ( The diameter of polythene pipe: Outer diameter 25mm Surface thickness ≥1.5mm)
- ☆ Drain hose should be short and drooping gradient should at less 1/100 to prevent the formation of air bubble.
- ☆ If drain hose cannot has enough drooping gradient, drain raising pipe should be added.
- ☆ To prevent bent of the drain hose, the distance between hoisting stand should is 1 to 1.5m.

# Install the cassette type indoor unit

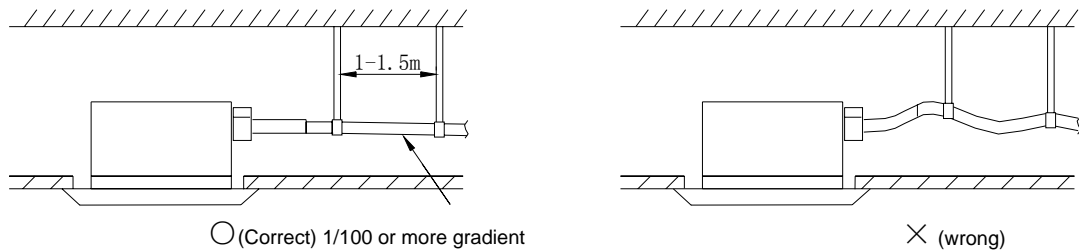

☆ Use the drain hose and clamp attached. Insert the drain hose to the drain vent, and then tighten the clamp.

☆ Entwine the big sponge on the clamp of drain hose to insulate heat.

☆ Heat insulation should be done to indoor drain hose.

## Drain step up pipe note

☆ The install height of the drain raising pipe should less than 280mm.

☆ The drain raising pipe should form a right angle with the unit, and distance to unit should not beyond 300mm.

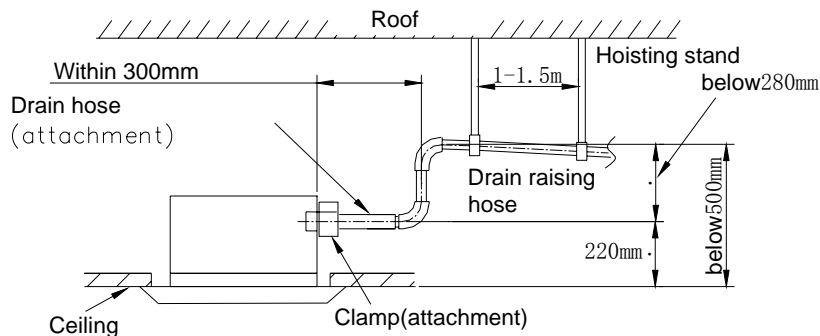
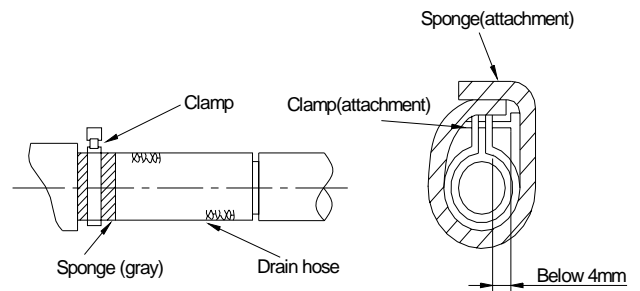

## Instruction

☆ The slant gradient of the attached drain hose should be within 75mm so that the drain hole doesn't have to endure the unnecessary outside force.

☆ Please install the drain hose according to the following process if several drain hoses join together.

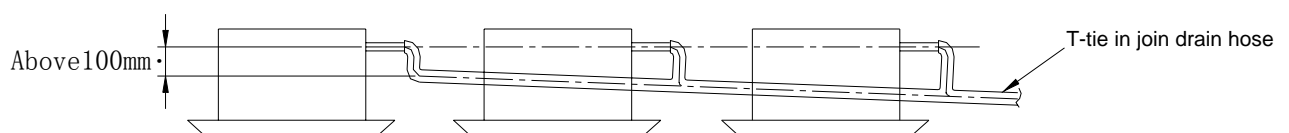
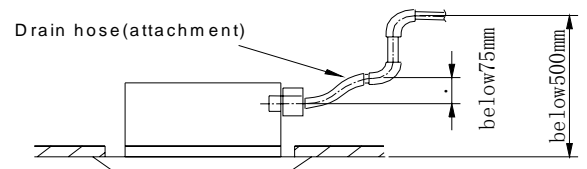

The specs of the selected join drain hose should fit the running capacity of the unit.

## Install the cassette type indoor unit

---

2 Check the smoothness of drain after installation.

☆ Check the drain state by immitting 600cc water slowly from the outlet vent or test hole.

☆ Check the drain in the state of refrigerating after installation of the electric circuit.

[Way of immiting]

Drain vent for repair use (plastic stopper is included) (drain the water in waterspout by this outlet vent)

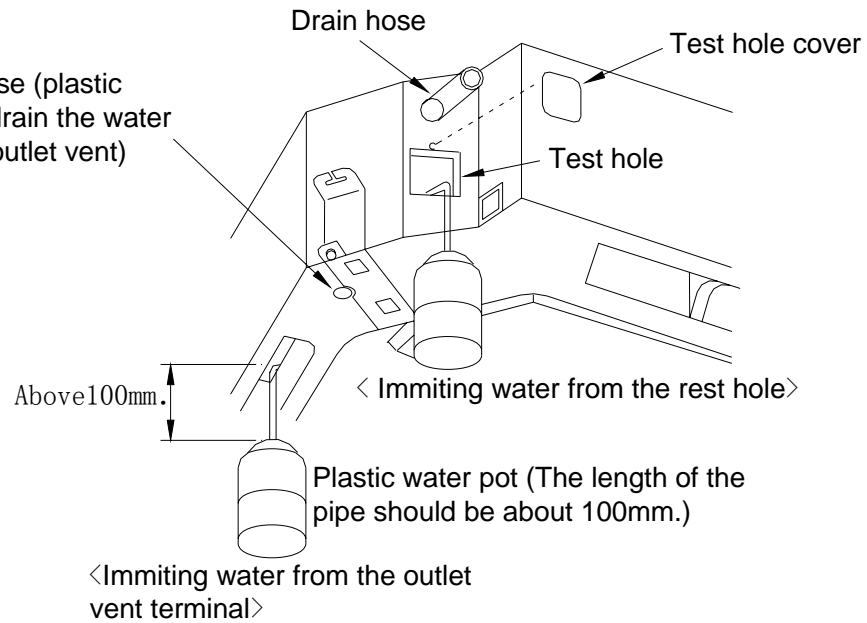

# Install the cassette type indoor unit

## ● Electrical wiring

**⚠ Note: The power of the entire indoor unit must be unity power supply**

- ☆ About the electrical wiring, please see the circuit diagram attached with the unit.
- ☆ All the installation of electrical wiring must be done by professional personnel.
- ☆ Please do take the earthing treatment.

### Wiring method of connection unit and controller

☆ Connection wiring (communication):

- ① Open electric box cover(1), drag the wiring (communication) from the rubber plug A, and impact them well individually by impact fastener.
  - ② Wiring according to the indoor side circuit diagram.
- ☆ Fix the impact fastener after connection.
  - ☆ Entwine the small sponge on the electric wire ( do entwine it to prevent condensation)
  - ☆ Impact tightly by impact fastener after connection and then fit on the electric box (1) and (2).
  - ☆ Connect the 3 cord rubber wire to the counter terminal of the 3 way terminal board.

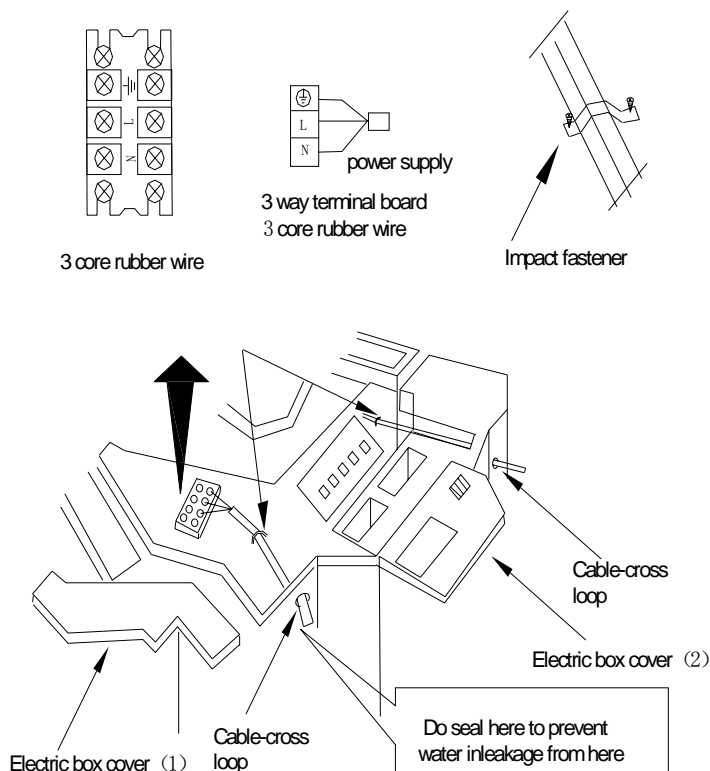

## Install the cassette type indoor unit

---

### ● Function description of functional dial switch S7

1. The 3-bit dial switch must be set before energizing the main board and it determines running state of indoor unit.
2. Function of it is as follow:

<b>Dial switch Silk screen</b>	<b>Function</b>	<b>Dial ON</b>	<b>Dial OFF</b>
1 (S/R)	Selection of memory mode: A: Selection between reset mode and standby mode after energizing B: This function is available without wired controller.	Standby after energizing	Reset after energizing
2 (L/I)	Selection between manual controller and receiver A: If manual controller is selected, remote-control function of receiver will be shielded. B: If receiver is selected, wired controller will be non-effective.	Selecting wired controller	Selecting receiver joint
3 (M/S)	Setting of main and slave indoor units A: For resolution of conflict among the modes. B: This function is available without wired controller.	Main indoor unit	Slave indoor unit

# Install the cassette type indoor unit

## ● Install the panel

1. Set the panel to the indoor unit body by matching the position of the swing flap motor of the panel to the piping position of the panel to the piping position of the indoor unit as shown by fig.4.

2. Install the panel

① Install the panel on the indoor unit temporarily. When install, hang the latch on the hook that is located on the opposite side of the swing flap on the panel of the indoor unit. (2 positions)

② Hang the remaining 2 latches to the hooks on the sides of the indoor unit.(Be careful not to let the swing motor lead wire get caught in the sealing material.)

③ Screw the 4 hexagon head screws under the latches in about 15mm. (The panel would rise)

④ Adjust the panel by turning it toward the direction pointed by the arrow as shown in fig.4, so that the adjust board connect the ceiling well.

⑤ Tighten the screws until the thickness of the sealing material between panel and indoor unit reduced to 5-8mm.

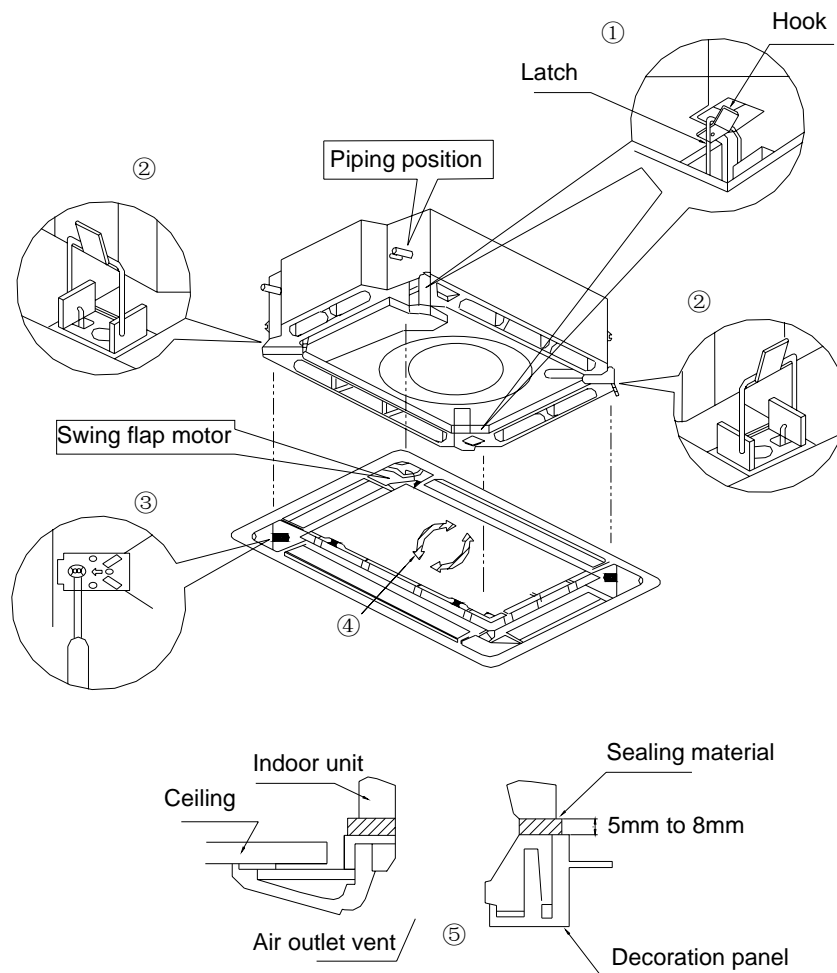

Fig 4



# Install the cassette type indoor unit

## Note

1. Improper screwing of the screws may cause the troubles shown in fig.5.

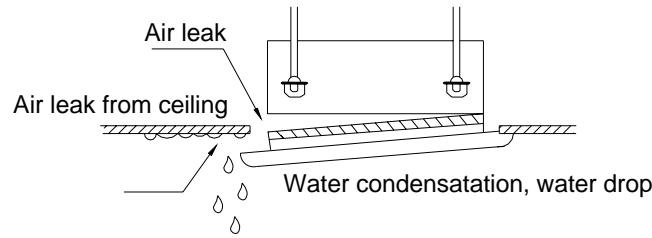

Fig.5

2. If gap still exist between ceiling and decoration panel after tightening the screws, readjust the height of the indoor unit. (As shown in fig.6)

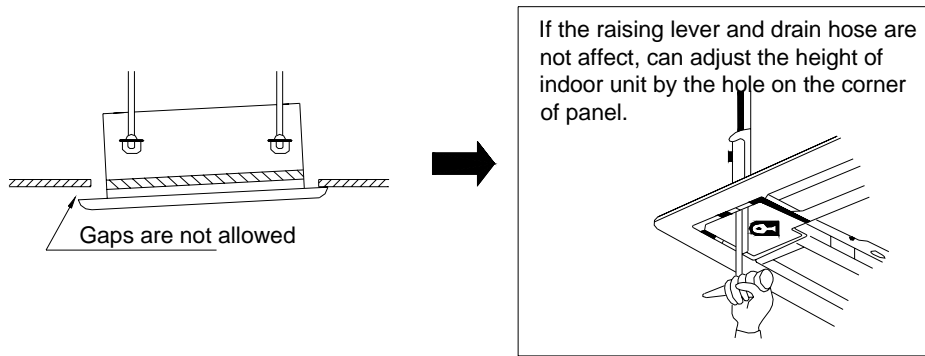

Fig.6

※ After fixing, be sure no gap left between the ceiling and the panel.

3. Wiring of the decoration panel (Fig.7)

☆ Connect the joints for swing flap motor lead wire (at 2 places) installed on the panel.

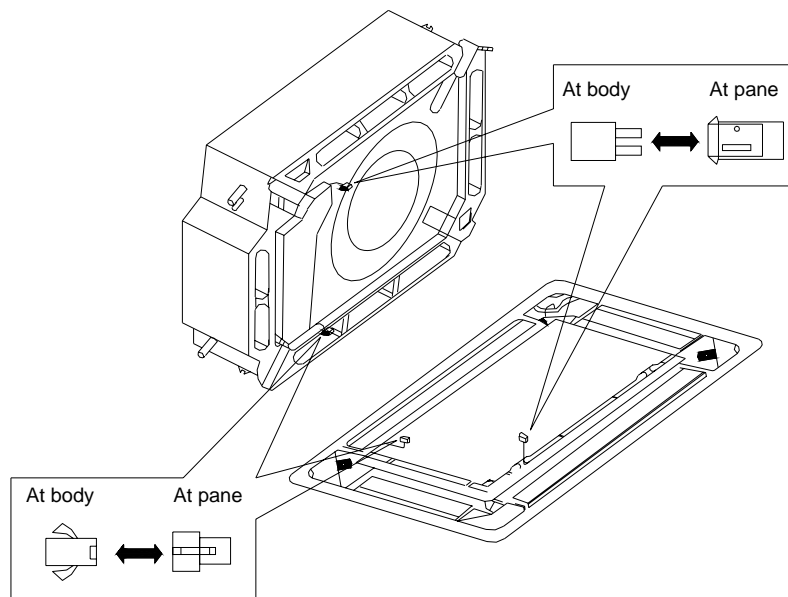
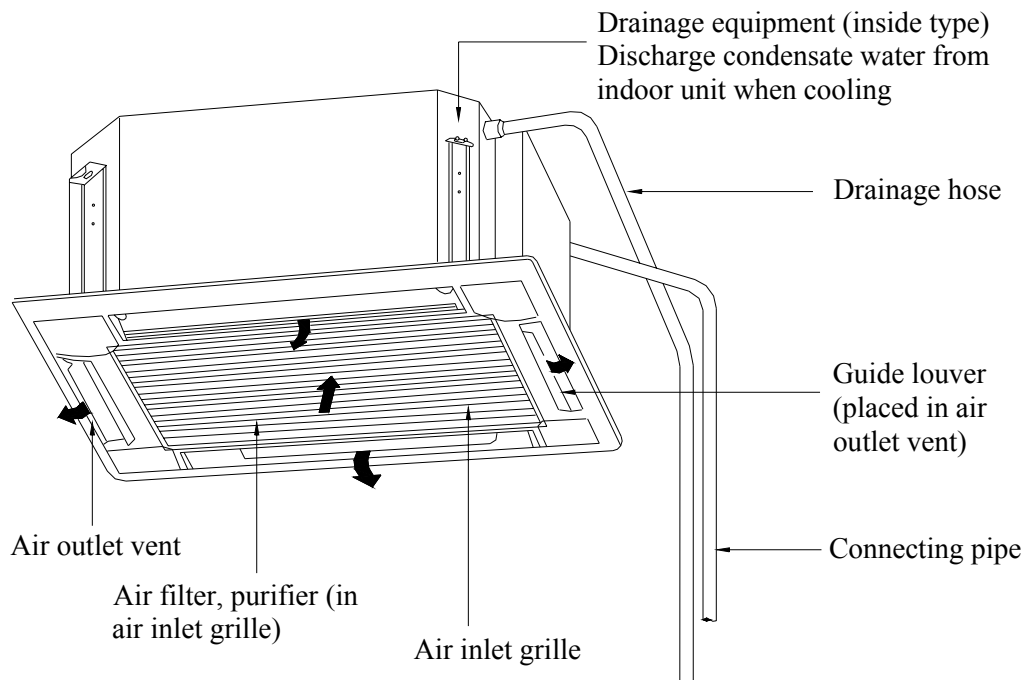

Fig.7

## Constitutes and Names of Parts of Cassette Type Indoor Unit



TGS-28FWCA  
TGS-36FWCA  
TGS-45FWCA  
TGS-50FWCA  
TGS-56FWCA  
TGS-63FWCA  
TGS-71FWCA  
TGS-80FWCA  
TGS-90FWCA  
TGS-100FWCA  
TGS-112FWCA  
TGS-125FWCA  
TGS-140FWCA

## Working Temperature Range

**Working Temperature Range**

	Indoor side state		Outdoor side state	
	Dry bulb temp. °C	Wet bulb temp. °C	Dry bulb temp. °C	Wet bulb temp. °C
Rated Cooling	27	19	35	24
Max. cooling	32	23	43	26
Min. cooling	21	15	18	—
Rated Heating	20	15	7	6
Max. heating	27	—	24	18
Min. heating	20	15	—15	—16

# Wired Remote Controller Operation Procedure

## The components of the wired remote control

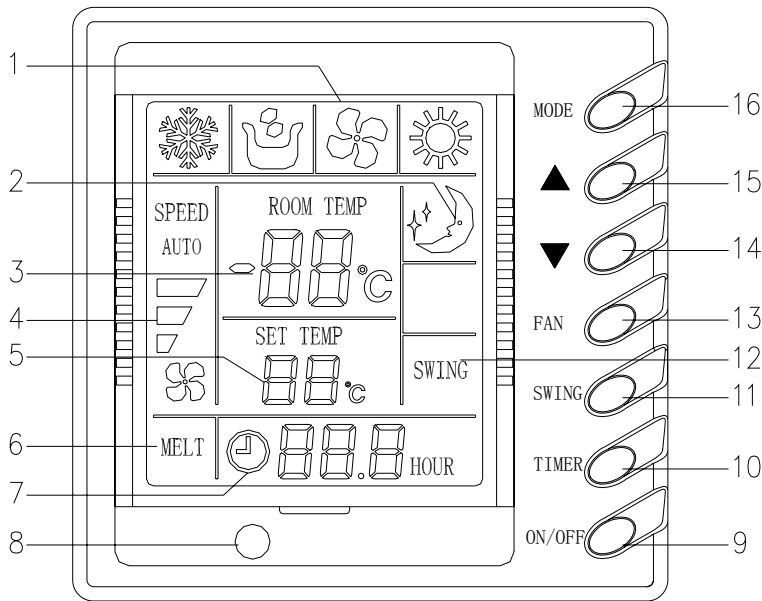

Fig.1

Every part of wired remote controller			
1	Operating mode display (Cool, Dry, Fan, Heat)	9	On/Off button
2	Sleep mode display	10	Timer button
3	Environmental temp. display / Malfunction display	11	Swing button
4	Fan control display (automatic, high, media, low)	12	Swing display
5	Set Temp. display	13	Fan control button
6	Defrosting display	14	Temp. / Timer reducing button
7	Timer display	15	Temp. / Timer rising button
8	Signal receptor	16	Mode button

### 1) On/Off (Fig.2)

- ❖ Press On/Off button to turn on air conditioner.
- Repress On/Off button once to turn off air conditioner.

**Note:** The displaying in fig.2 is the turned off state after connecting with power supply. After connecting power and normal communication, the environmental temp. will be displayed on LCD under state of both turned on or off. At this time, as shown in fig.3 there is no pane displayed on LCD, which means that the air conditioner is turned off.

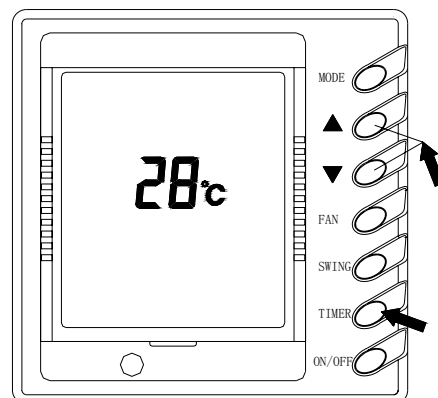

Fig2

# Wired Remote Controller Operation Procedure

2) **Timer setting** (Fig.3, the following sketch is displayed according to the functions of wired remote controller)

- ❖ Press TIMER under off state can set On Time; press TIMER under on state can set Off Time.
- ❖ Under the circumstance that without setting time ( there isn't information in the Timer Time Display Zone), press TIMER, then the LCD will display the pattern of “⌚ xx.x Hours” , and the “⌚” and “hours” will keep blinking for 0.5s, press adjusting button“▲”or“▼”can adjust set time. After adjusting set time by button “▲”or“▼”, repress TIMER once, the pattern “⌚” and “hours” will no longer blinking, which indicates that TIMER had been set.
- ❖ Press TIMER once after electrify, “⌚ 0.0 hour” is displayed and both of the two patterns are blinking on LCD, repress TIMER once again, then the Timer pattern no longer displayed on LCD, which indicated that the TIMER setting had been cancelled.
- ❖ Under the circumstance of TIMER time had been set ( i.e. the state that “⌚” and “hours” don't blink) , repress TIMER, then the “⌚ xx.x hours” will be redisplayed on LCD (note: “xx.x” indicates the set time of last time, and will be cancelled after electrify), and both “⌚” and “hours” are blinking, at this time, adjust “▲”or“▼”to reset timer, or repress TIMER to confirm timer function.
- ❖ The timer of turning on/off ranged from 0.5-24 hours. Every single press of“▲”or“▼”, the set time will be added or subtracted 0.5 hour. Press “▲”or“▼” serially the set time will add or subtract 0.5 hour automatically for every 0.5s. The adjusting range of “▲”and“▼”are from 0 to 24, and the mode is recycling mode.

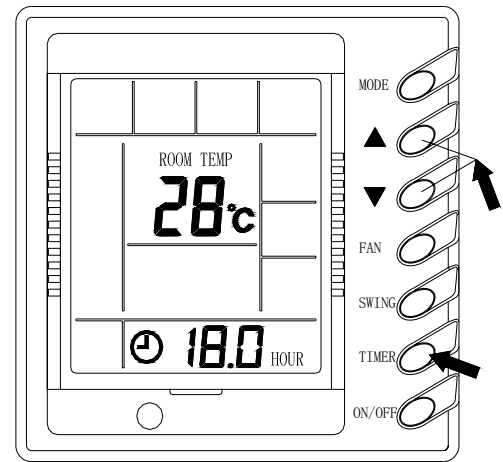
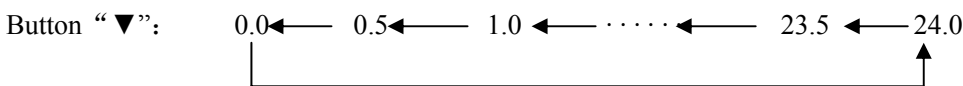
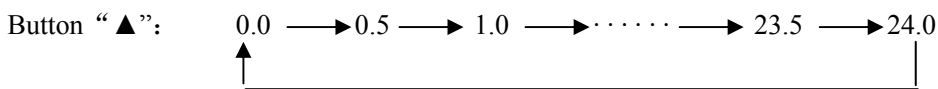

Fig3



**Note:** The above displayed is the relative displaying zone.

# Wired Remote Controller Operation Procedure

## 3) SLEEP mode setting (fig.4)

- ❖ When under the cooling or dehumidifying mode, after receiving the SLEEP order for 1 hour, the previous set temp.  $T_{set}$  will be risen for  $1^{\circ}\text{C}$ , and another  $1^{\circ}\text{C}$  will be risen after 2 hours that means that the temperature been risen  $2^{\circ}\text{C}$  within 2 hours. Then the unit will run according to this set temp.
- ❖ When under the heating mode, after receiving the SLEEP order for 1 hour, the previous set temp.  $T_{set}$  will be lower for  $1^{\circ}\text{C}$ , and another  $1^{\circ}\text{C}$  will be lower after 2 hours that means that the temperature been lowered  $2^{\circ}\text{C}$  within 2 hours. Then the unit will run according to this set temp.
- ❖ There is no SLEEP mode under fan mode.

Note: The wired remote controller has no SLEEP mode button; if SLEEP mode is needed to be set, complete the procedure by wireless remote controller.

## 4) Swing Control (Fig.5)

- ❖ Press Swing button then the swing mode will be operated by the air conditioner.
- ❖ Repress Swing button once to stop swing mode.

Note: There is no swing mode for duct type indoor unit

## 5) Fan Speed Control (fig.6)

- ❖ Every press of the fan speed button, the fan speed will be changed according to the following order:

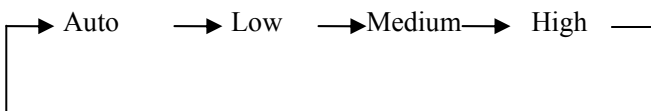

- ❖ Under dehumidifying mode: Fan speed will be set to low automatically.

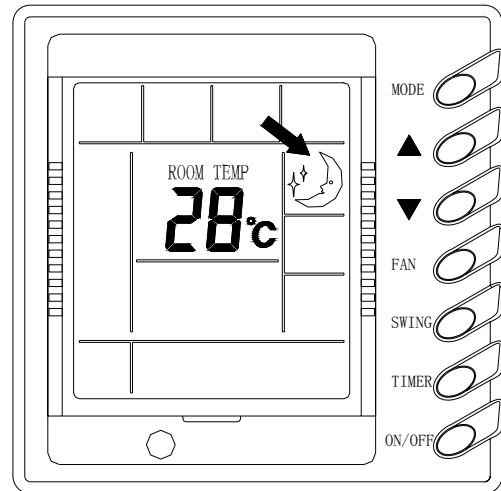

Fig4

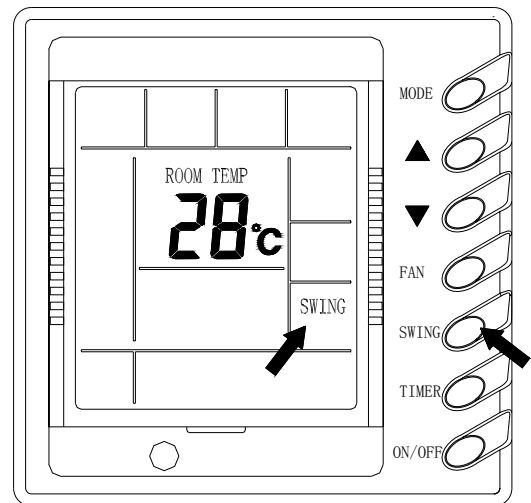

Fig5

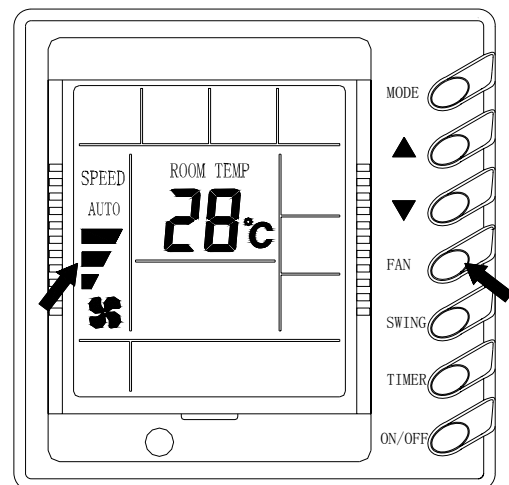

Fig6

# Wired Remote Controller Operation Procedure

## 6) Temp. adjusting (Fig.7)

❖ Under the state without time setting, press“▲”and“▼”to adjust temp..

▲: To rise set temp.;

▼: To reduce set temp.

(every press of this button, temp. will be risen or subtracted for 1°C.)

❖ Temp. adjusting ranged from 16°C ~ 30°C under any running mode.

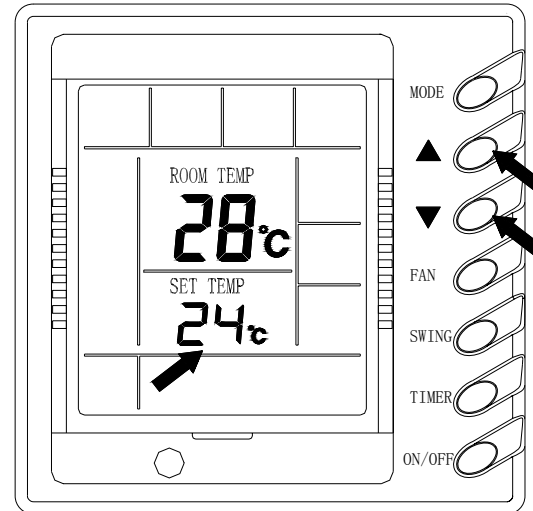
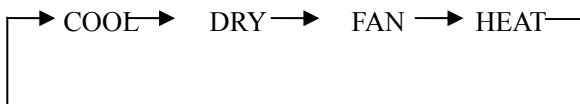

Fig7

## 7) Set of running mode (Fig.8)

❖ Every once press of the mode key, the running mode would be changed according to the following order:



❖ Under cooling mode, the display of cooling will on, and the set temp. should be lower than the present room temp. If the set temp. is higher than the present room temp., air conditioner would not enter cooling mode.

❖ Under dehumidify mode, display of dehumidify will on. Fan will run in low speed in certain temp. range. The dehumidifying effect of this mode is better than that of cooling mode, and saves more energy.

❖ Under heating mode, the display of heating will on. The set temperature should be higher than that of present room; if the set temp. was lower than that of present room, heating mode would not be operated.

❖ Under fan mode, the display of fan will on.

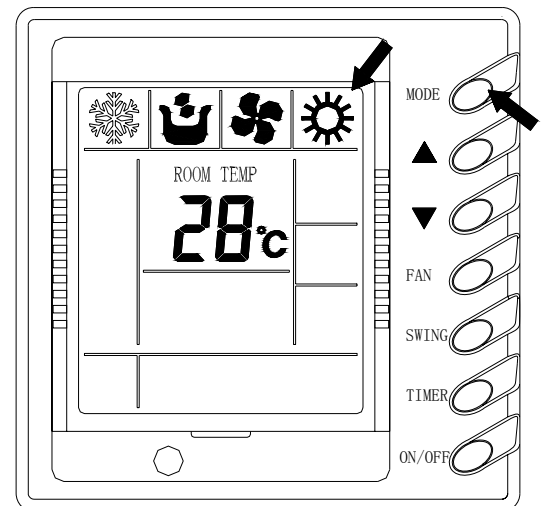

Fig8

## 8) Malfunction display (fig.9)

❖ When malfunction happened in running, malfunction code will be shown in environmental temp. display zone. Fig.9 indicates that the compressor is operating high pressure protect.

❖ When malfunction happened, except fan mode will still work in normal, outdoor unit and fan will close under mode of cooling, dehumidify and heating, but LCD display will not be affected.

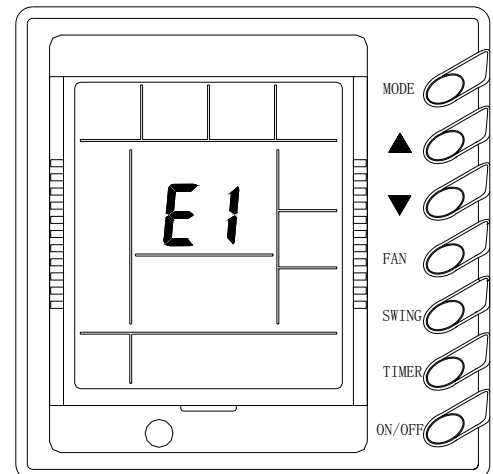

Fig9

# Wired Remote Controller Operation Procedure

---

- ❖ When controller displaying malfunction, please turn off the unit to stop displaying and has it repaired by specialized personnel.

**The meaning of malfunction code is as following:**

Malfunction code	Malfunction
E1	High pressure protection of compressor
E2	Indoor anti-frozen protection
E3	Low pressure protection of compressor
E4	Discharge temp. protection of compressor
E5	Compressor overload protection
E6	Transmit malfunction
E7	Modes conflict
F0	Indoor environment temp. sensor mal-function
F1	Indoor pan tube inlet tube temp. sensor malfunction
F2	Indoor pan tube middle temp. sensor malfunction
F3	Indoor pane tube outlet tube temp. sensor malfunction
F4	Outdoor environment temp. sensor malfunction
F5	Outdoor pan tube inlet tube temp. sensor malfunction
F6	Outdoor pan tube middle temp. sensor malfunction
F7	Outdoor pan tube outlet tube temp. sensor malfunction
F8	Discharge temp. sensor 1 (rated frequency) malfunction
F9	Discharge temp. sensor 2 (digital) malfunction
FA	Greasy temp. sensor 1 (rated frequency) malfunction
Fb	Greasy temp. sensor 2 (digital) malfunction
Fc	High pressure sensor malfunction
Fd	Low pressure sensor malfunction

# Remote controller operation procedure

## Names and functions of every button of the remote control

The remote control of the Ducked type indoor unit is shop piece.



### NOTE!

- Make sure that there is no obstruction between the remote control and the signal receptor.
- The remote control signal can be received at the distance of up to about 10m.
- Don't drop or throw the remote control.
- Don't let any liquid flow into the remote control.
- Don't put the remote control directly under the sunlight or any place where is very hot.

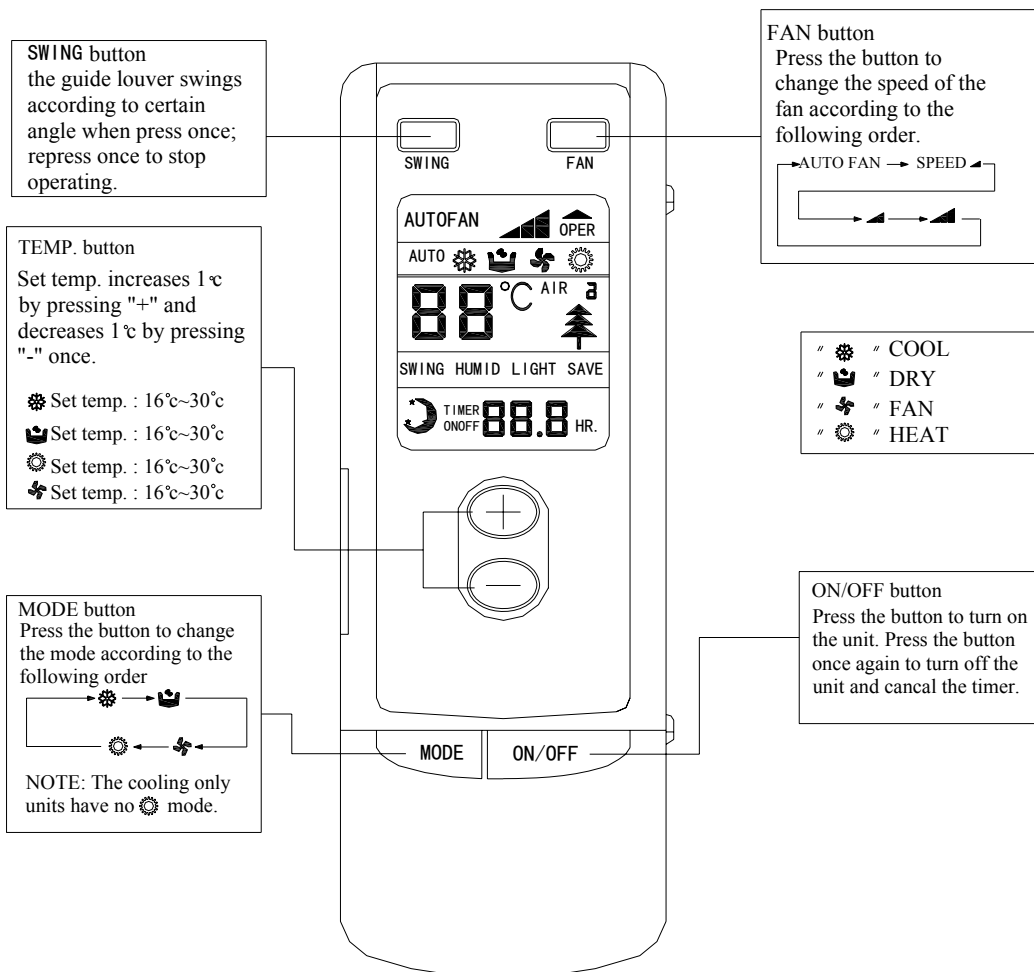

### NOTE!

After every indoor unit received the turn off signal, the fan and electric inflate valve will continue to work for 20-70mins to make use of the rest cool or rest heat, while for preparation for the next work. And this is normal phenomenon.



# Remote controller operation procedure

## Names and functions of every button of the remote control (Remove the cover)

### NOTE!

This type of remote control is a kind of general use remote control that is suitable for several types (function) of air conditioner units. Please understand that the functions and buttons that are not suitable for this air conditioner will not be introduced.

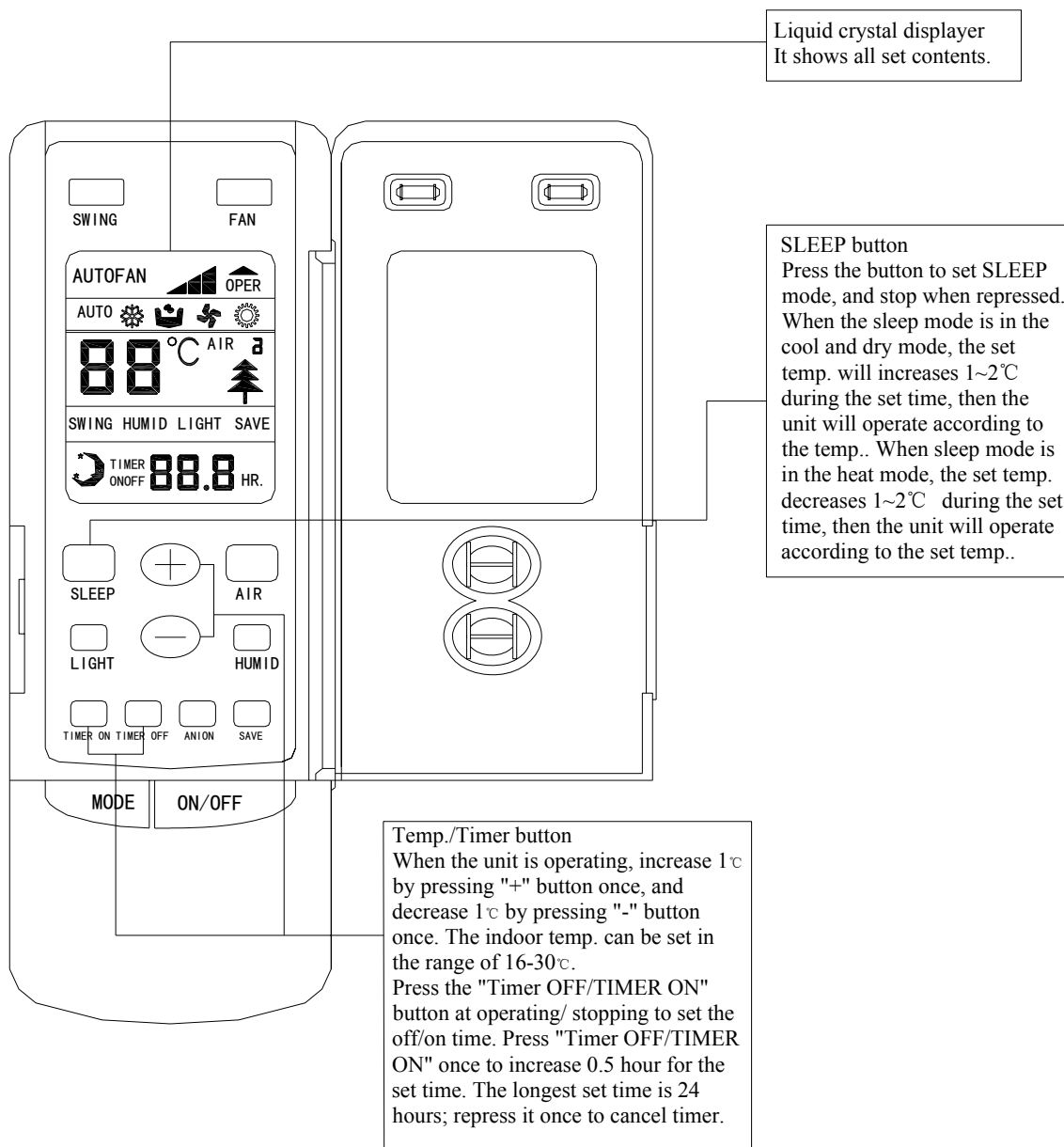

# Remote controller operation procedure

## Operation procedure

### Normal procedure

1. Press ON/OFF button after connected with the power, then the unit is operating.
2. Press MODE button to choose the need operation mode.
3. Press button SWING to make the guide louver swings according to certain angle when press once; repress once to stop operating.
4. Press FAN button to set the fan speed.
5. Press +/- button to set the need temp..

### Selectable procedure

6. Press SLEEP mode to set the sleep state.
7. Press TIMER OFF button to set the set time.
8. Repress ON/OFF turn off indoor air conditioner. Under cooling and dehumidify mode, rest cool air will be blow for 20~70s; Rest heat air will be blow for 60s under heating mode.

**Note: When the operating mode selected by the indoor unit is clash with the one selected by the outdoor unit, the remote controller will display the operating clash after 5 seconds and the power light will flicker, then the indoor unit turns off. At this time, the units will become normal after the operating mode of the indoor unit is changed to cooperate with the outdoor unit. Cool mode can cooperate with dry mode, and fan mode can cooperate with any mode.**

### How to insert batteries

Two batteries( Two AAA dry-cell batteries) are used by the remote control

1. Remote the cover from the back of the remote control downward, take out the worn batteries and insert two new ones (Make sure the two poles are correct)
2. Re-attach the cover.

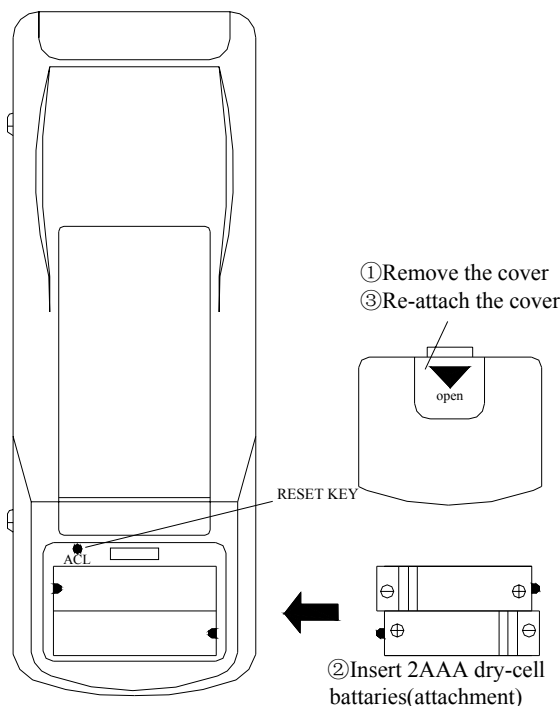

1. All the prints and code no. will be showed on the displayer after the insert of batteries. The remote control can be operated after 10sec.
2. The lifetime of the batteries is about one year.
3. Don't confuse the new and worn or different types of batteries.
4. Remove batteries when the remote control is not in use for a longtime to avoid mal-function caused by liquid leakage.
5. The remote control should be placed about 1m or more from the TV set or any other electric appliances.
6. The remote control should be used in the receivable range (the reception range is 10m)
7. When the remote control can not be controlled in the situation of inserted batteries, please remove the back cover and press "ACL" button to make it normal.

## Operation Method When Meeting An Emergency

---

### ● Operation Method When Meeting An Emergency

When wireless remote controller is lost or damaged, the following method could be adopted to control cassette type indoor unit:

- ☆ When the unit is turned off, press AUTO button on corner outer cover II , then the unit begin operate in cooling with the fan run in high speed. **The temp. will be set to 26°C automatically.**
- ☆ When the unit is turned off, press TEST button on the corner outer cover II , then the unit begin running in heating and the fan is running in high speed. **The temp. will be set to 20°C automatically.**
- ☆ When the unit is running, press AUTO button on corner outer cover II , then the unit stops running; under the running state of heating, press TEST button on corner outer cover II , then the unit stops running.

### Note!

Prevent using the operating method for meeting an emergency when the wireless remote controller could be used in normal. There are 3 lights on corner outer cover II , red for power, green for running, and yellow for timer.

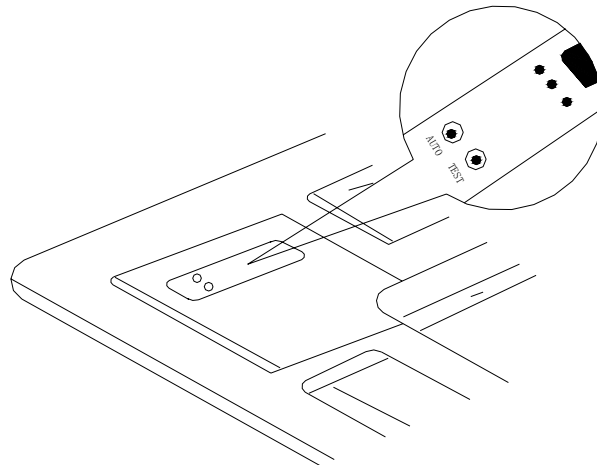

# Malfunction Debarring

---



## Warning!

- Cut down the main power switch immediately if malfunction (such as smell the burning odor etc.) happened, and then contact service center. If the abnormal state is maintained, the unit may be damaged or electric shock or fire may be happened.
- Do not refit the conditioner. Please contact service center to repair or move the conditioner.
- **Check the following items before contacting maintenance center**

Phenomena	Reason	Remedial Measures
Air conditioner doesn't run at all	Blow of fuse or breaker	Change fuse or close breaker
	Power cut	Restart when there is power supply
	Don't connect with power	Connect power well
	Low batteries of wireless remote controller	Change new batteries
	Wireless remote controller exceed remote control area	Signal could be received within 8m
Air conditioner runs but stops immediately	Blockage in inlet or outlet vent of indoor or outdoor unit	Clean out blockage
Abnormal cooling or heating	Blockage in inlet or outlet vent of indoor or outdoor unit	Clean out blockage
	Improper of temp. setting	Adjust settings in wireless remote controller
	Low setting of fan speed	Adjust settings in wireless remote controller
	Incorrect of wind direction	Adjust settings in wireless remote controller
	Door or window opened	Close
	Direct sun burn	Hang curtain or jalousie before windows
	Too many people in room	
	Too many heater in room	
	Filter blocked by dirt	Clean filter

## ● Instruction

If problem still cannot found out after above checking, please contact service center and instruct phenomena and model.

## Malfunction Debarring

---

### ● The following circumstance are not malfunction

“Malfunction”		Reason
Air conditioner doesn't run	Start up unit immediately after turned off	The overload protects switch makes it run after 3 minutes delay.
	When opening power	Run for about 1 minute without other actions
Mist is blown from air conditioner	When cooling	The high humidity air in room is cooled rapidly
Noise is heard from air conditioner	Slight click sound heard once begin running	Sound of initialization for electric expand valve
	Hissing sound heard continuously when cooling	The sound for gas refrigerant flowing in the unit
	Hissing sound heard when starting or stopping	The sound for gas refrigerant stops flow
	Slight hissing sound heard when running or after running	Sound for running of drainage system
	Creak sound heard when running or after running	The grating sound caused by expands of panel and other parts for the change of temperature
Dust be blown for air conditioner	Started up after long time's doesn't runs	Dust in indoor unit be blown out
Odor gives out from air conditioner	When running	This is because when air conditioning, odors or cigarette smoke from the room that was sucked in is discharged again.

### ● After-sales Service

☆ When having quality or other problems when purchasing air conditioner, please contact the local service center.

# Maintenance Method

**When air conditioner won't be used for a long time, please cut off the main power supply of air conditioner.**



## Warning !

- Do not turn off the unit and cut off the main power supply when cleaning the air conditioner, otherwise electric shock or harm may happen.
- It is forbidden to wash air conditioner by water rinsing, otherwise electric shock may happen.

## ● Cleaning air filter

When the usage environment has lots of dust, air filter should be cleaned more frequently (about once 6 months).

### 1. Open air inlet grille

Pull the 2 handle on air inlet grille at the same time with the direction showed by arrow in fig. I, pull down slowly.

(Reverse when closing)

### 2. Disassembly air filter

As shown in fig. II, pull the handle behind air inlet grille, raise it and disassembly. Then discharge the 3 purifier fixed on filter.

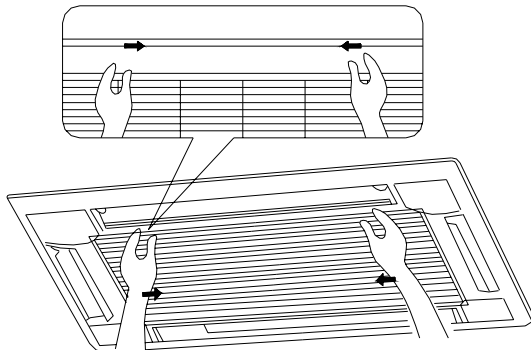

Fig. I

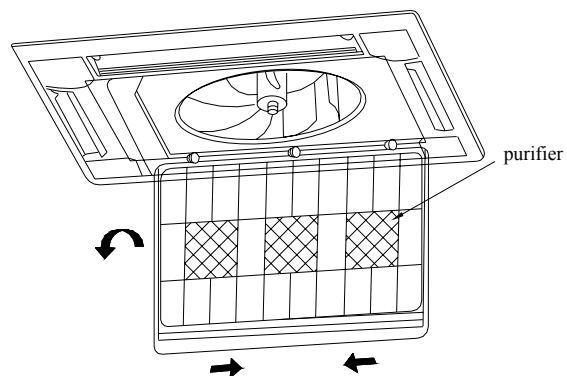

Fig. II

### 3. Clean

Adopts cleaner or water to wash filter; if the filter is too dirty ( like oil stain on it ), adopts warm water ( lower than 45°C ) with neutral scourer to clean it, then dry it in the shade.



## Note !

- Do not clean the filter by hot water whose temp. is higher than 45°C to prevent fade or deformation.
- Do not burn it on fire or the filter would catches fire or deformation.

### 4. Install air filter

Fix the 3 purifiers on filter, install filter on the several bulges on top of air inlet grille, pull the handle behind air inlet grille toward inside to fix filter. As shown in fig. III.

### 5. Close air inlet grille (Refer to the 1<sup>st</sup> step)

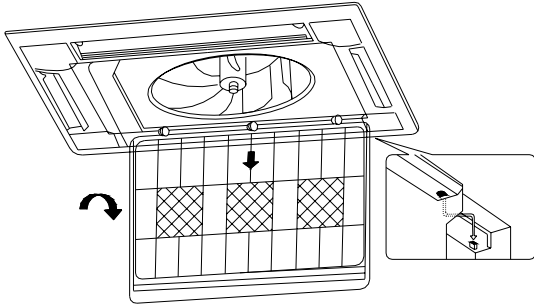

Fig. III

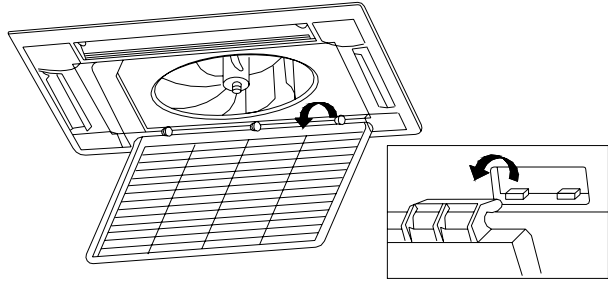

Fig. IV

## ● Clean air inlet grille

1. Open air inlet grille (the same with the 1st step of Clean Air Filter)
2. Take out air filter (the same with the 2nd step of Clean Air Filter)
3. Take out air inlet grille

Open air inlet grille for an angle of  $45^{\circ}$ , as shown in fig. IV, rise it.

4. Clean

Clean it by pubescence brush, water and neutral cleaning, then throw water or dry it.



### Note!

- Do not use water above  $45^{\circ}\text{C}$  to wash the panel to prevent fade or deformation.
5. Install air inlet grille (refer to 3rd step)
  6. Install air filter (refer to the 4th step of Clean Air Filter)
  7. Close air inlet grille (refer to the 1st step)

## ● Install and change of air purifier

1. Open air inlet grille (the same the 1st step of Clean Air Filter)
2. Disassembly purifier  
As shown in fig V, disassembly air filter, screw out fixing bolts fixed on purifier on filter, then purifier could be disassembly.
3. Take out the package sack of static fiber net filter, then install the filter in stand of purifier, and fix purifier on air filter.
4. Install air filter (the same with the 4th step of Clean Air Filter)

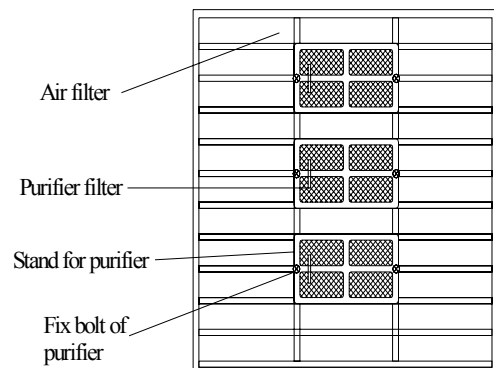

Fig. V

# Maintenance Method

---

## Function and usage period for air purifying

- ☆ Could adsorb CO, CO<sub>2</sub>, benzene, aldehydes and odor of gasoline etc..
- ☆ Could adsorb deleterious material that is smaller than 1 μ m in air, as dust, pollen, bacteria, and virus.
- ☆ Usage period is 6 months to 1 year. If it is necessary to be changed, purchase new purifier in the nearest TOYOTOMI special engaged maintenance center.

## ● Clean Outlet vent and Surface Panel

- ☆ Clean the surface panel by soft dry cloth or wet cloth with neutral scourer.
- ☆ It is forbidden to clean surface panel by gasoline, benzene, diluents, cleansing powder etc..
- ☆ If the guide louver is too dirty, it may be removed to be cleaned. (As narrated below)

## Disassembly and install of guide louver

### 1. Disassembly guide louver

Screw bolts in both end of guide louver to loose.



- Do not wipe guide louver powerfully when cleaning, otherwise fluff on surface would fall off.

### 2. Install guide louver

Rotate guide louver slightly could install the protruding edge of both end into grooves on both end of guide louver, and then tighten bolts.

## ● Maintenance before or after usage season

### Check before the usage season

- ☆ Check if there is blockage in inlet or outlet vent of air conditioner.
- ☆ Check if the earthing wire had earthed reliably.
- ☆ Check if the air filter had been installed well.
- ☆ In order to start up the air conditioner smoothly after long time's turned off, turn on the main power supply 8 hours before turning on the air conditioner.

### Maintenance after usage season

- ☆ Clean filter and body of air conditioner.
- ☆ Cut off the main power supply of air conditioner.



## Model and Technical Parameter

### ● Parameter of cassette type indoor unit

Model	TGS-28FWCA	TGS-36FWCA	TGS-45FWCA	TGS-50FWCA
Function	Cooling and heating	Cooling and heating	Cooling and heating	Cooling and heating
Cooling Capacity (kW)	2.8	3.6	4.5	5.0
Heating Capacity (kW)	3.2	4.0	5.0	5.8
Air Flow Rate (m <sup>3</sup> /h)	680	680	680	680
Sound Level(dB(A))	37	37	37	37
Output of Motor (kW)	0.035	0.035	0.035	0.035
Power Supply	220-240V~ 50Hz			
Anti-electric Shock Protect Type	I			
Unit Dimensions(W×D×H) (Main body/Panel)	Main body: 840×840×190 Panel: 950×950×60			
Package Dimensions(W×D×H) (Main body/Panel)	Main body: 960×960×257 Panel: 1025×1040×115			

Model	TGS-56FWCA	TGS-63FWCA	TGS-71FWCA	TGS-80FWCA
Function	Cooling and heating	Cooling and heating	Cooling and heating	Cooling and heating
Cooling Capacity (kW)	5.6	6.3	7.1	8.0
Heating Capacity (kW)	6.3	7.0	8.0	8.8
Air Flow Rate (m <sup>3</sup> /h)	1180	1180	1180	1180
Sound Level (dB (A))	39	39	39	39
Output of Motor (kW)	0.035	0.035	0.035	0.035
Power Supply	220-240V~ 50Hz			
Anti-electric Shock Protect Type	I			
Unit Dimensions(W×D×H) (Main body/Panel)	Main body: 840×840×240 Panel: 950×950×60			
Package Dimensions(W×D×H) (Main body/Panel)	Main body: 960×960×310 Panel: 1025×1040×115			

Model	TGS-90FWCA	TGS-100FWCA	TGS-112FWCA	TGS-125FWCA
-------	------------	-------------	-------------	-------------

Function	Cooling and heating	Cooling and heating	Cooling and heating	Cooling and heating
Cooling Capacity (kW)	9.0	10.0	11.2	12.5
Heating Capacity (kW)	10.0	11.0	12.5	13.5
Air Flow Rate (m <sup>3</sup> /h)	1860	1860	1860	1860
Sound Level (dB (A))	40	40	40	40
Output of Motor (kW)	0.06	0.06	0.06	0.06
Power Supply	220-240V~ 50Hz			
Anti-electric Shock Protect Type	I			
Unit Dimensions(W×D×H) (Main body/Panel)	Main body: 840×840×320 Panel: 950×950×60			
Package Dimensions(W×D×H) (Main body/Panel)	Main body: 960×960×394 Panel: 1025×1040×115			

Model	TGS-140FWCA
Function	Cooling and heating
Cooling Capacity (kW)	14.0
Heating Capacity (kW)	14.5
Air Flow Rate (m <sup>3</sup> /h)	1860
Sound Level (dB (A))	40
Output of Motor (kW)	0.06
Power Supply	220-240V~ 50Hz
Anti-electric Shock Protect Type	I
Unit Dimensions(W×D×H) (Main body/Panel)	Main body: 840×840×320 Panel: 950×950×60
Package Dimensions(W×D×H) (Main body/Panel)	Main body: 960×960×394 Panel: 1025×1040×115

☆ The above performance parameter is measured according to the standard of GB/T18837-2002, and its cooling or heating capacity and sound level are tested before leaving factory.

☆ If the parameter changed, refer to the data offered on nameplate.



**66129904804**