



**User's Manual  
of  
Electromagnetic Flow Meter**





## 目录

# Contents

- 03** BRIEF INTRODUCTION
- 04** WORKING PRINCIPLES
  - Measuring Principles
  - Converter Circuit Schematic
- 05** PRODUCT CLASSIFICATION
  - Product Components
  - Product Models
- 05** TECHNICAL SPECIFICATION
- 07** DRAWINGS AND DIMENSIONS
- 08** LECTOTYPE PRINCIPLE
- 12** CONVERTER OPERATION MENU AND PARAMETER SETUP
  - Keypad and Display
  - L\_MagB\_4 key parameters and setting
  - Details Parameters
- 22** INSTALLATION
- 24** WIRING
  - Grounding
  - Converter Terminals and Definition
  - Remote-type Wiring
  - Output Signal Wiring
- 29** SELF-DIAGNOSTICS AND TROUBLESHOOTING
- 30** PACKAGING
- 30** TRANSPORTATION AND STORAGE
- 30** OPERATION

---

# Brief Introduction

## 1.1 Features

- Measurement is not affected by the variation of flow density, viscosity, temperature, pressure and conductivity. High accuracy measurement is guaranteed according to the linear measurement principle.
- No obstacle in the pipe, no pressure-loss and lower requirement for straight pipeline.
- DN 6 to DN2000 covers a wide range of pipe size. A variety of liners and electrodes are available to satisfy different flow characteristic.
- Programmable low frequency square wave field excitation, improving measurement stability and reducing power consumption.
- Implementing 16 bits MCU, providing high integration and accuracy; Full-digital processing, high noise resistance and reliable measurement; Flow measurement range up to 1500:1.
- High definition LCD display with backlight.
- RS485 or RS232 interface supports digital communication.
- Intelligent empty pipe detection and electrodes resistance measurement diagnosing empty pipe and electrodes contamination accurately.
- SMD component and surface mount technology (SMT) are implemented to improve the reliability.

## 1.2 Main Applications

Electromagnetic flowmeter can be used to measure the volume flow of conductive fluid in a closed pipeline. It is widely applied in the flow measurement and control in the fields of chemical and petroleum industry, metallurgy industry, water and waste water, agriculture and irrigation, paper making, food and beverage industry and pharmaceutical industry.

## 1.3 Ambient and Working Conditions

Ambient temperature: sensor: -25°C to + 60°C; converter: -25°C to + 60°C.

Relative humidity: 5% to 90%; Fluid conductivity:  $\geq 5\text{m S/cm}$

Maximum fluid temperature: Compact type: 60°C

Remote type: Teflon 150°C

Neoprene 80°C; 120°C

Polyurethane 70°C

# Working Principles

## 2.1 Measuring Principles

The measuring principle of electromagnetic flowmeter is based on the electromagnetic induction law of Farady. The sensor is mainly composed of measuring tube with isolate lining, a pair of electrodes installed by penetration of the measuring tube wall, a pair of coils and iron core to produce working magnetic field. When the conductive fluid flows through the measuring tube of the sensor, the voltage signal in direct proportion to the average flow velocity of the fluid will be induced on the electrodes. The signal is amplified and treated by the transmitter to realize various display functions.

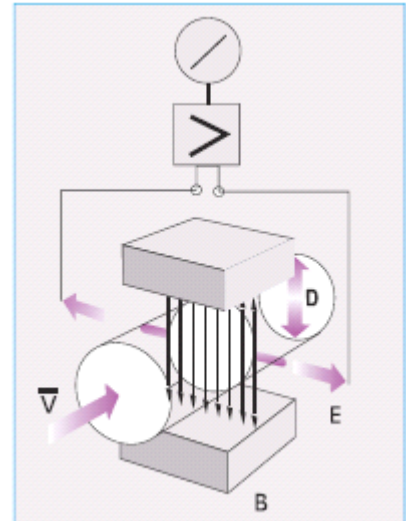

## 2.2 Converter Circuit Schematic

The converters supplies a stable exciting current to the coil in the sensor of electronic flowmeters to get B constant and amplifies the electromotive force and convert it into standard signals of current or frequency so that the signals can be used for displaying, controlling and processing. The schematic of converter circuit is shown in Fig. 2.1.

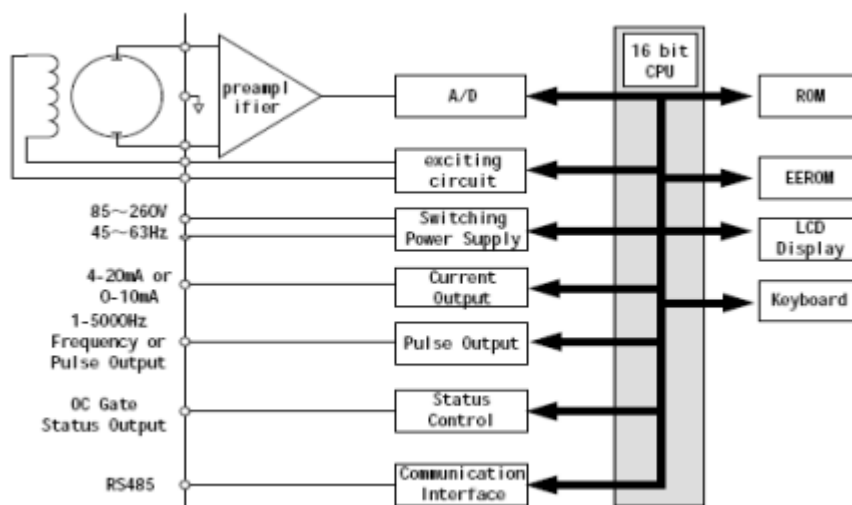

Fig. 1 Schematic of converter circuit

## Product Classification

Electromagnetic flowmeter is composed of sensor and converter. It has two forms: compact-type and remote-type. The remote-type also needs a special double-layer shielded cable to connect the converter and the sensor. There are seven kinds of electrode materials and four kinds of lining materials available for sensor.

## Technical Specifications

Peak flow rate	15 m/s		
Accuracy (refer to accuracy curve)	indication $\pm$ 0.5%(flow rate no less than 0.8m/s)		
Conductibility of fluid	$\geq$ 5 $\mu$ s/cm		
Nominal pressure	DN15~DN150	4.0MPa	
	DN15~DN600	1.6MPa	
	DN200~DN1000	1.0MPa	
	DN700~DN3000	0.6MPa	
Ambient temperature	sensor	-25 $^{\circ}$ C~+60 $^{\circ}$ C	
	compact flowmeter and converter	-10 $^{\circ}$ C~+60 $^{\circ}$ C	
The liner material and maximum temperature of fluid	liner material	Remote-type	Compact-type
	polytetrafluoroethylene	100 $^{\circ}$ C;150 $^{\circ}$ C(special order required)	70 $^{\circ}$ C
	polyvinyl fluoride	100 $^{\circ}$ C;150 $^{\circ}$ C(special order required)	70 $^{\circ}$ C
	fluorinated ethylene-propylene(FEP)	100 $^{\circ}$ C;150 $^{\circ}$ C(special order required)	70 $^{\circ}$ C
	polychloropree rubber	80 $^{\circ}$ C;120 $^{\circ}$ C(special order required)	70 $^{\circ}$ C
	polyurethane	80 $^{\circ}$ C	70 $^{\circ}$ C
Electrode type	Fixed type(DN150~DN2600); Blade type(DN300~DN1600)		
Material of signal electrode and grounding electrode	mo-containing stainless steel,hastelloy B,hastelloy C,titanium alloy,tantalum alloy, platinum-iridium alloy,stainless steel-coated wolfram carbide		
Flange Material	carbon steel		
Grounding flange material	stainless steel 1Cr18Ni9Ti		

Material of inlet protection flange	DN15~DN600	stainless steel 1Cr18Ni9Ti
	DN700~DN3000	carbon steel
Shell protection	DN15~DN150 remote sensor with rubber or polyurethane liner	IP65,IP68(special order required)
	DN200~DN2600 remote sensor with rubber or polyurethane liner	IP68 5~10m underwater
	other sensor and all kinds of converter	IP65
Spacing(remote type)	Generally, the spacing between converter and sensor is no longer than 100 meters, special order will be required when it is longer than 100 m.	

- General Specification of Converter

Power supply: AC 85-265V, 45-63Hz, ≤20W; DC 11-40V

Converter display and operation: four keys are available to set all parameters. External handheld or PC can be used to do the configuration. High resolution LCD display with backlight, empty pipe detection and self-diagnostic function are equipped in the converter.

Digital communication: RS485, RS232, MODBUS, REMOTE

Output Signals:

- Current output: fully-isolated, 4-20mA/0-10mA  
load resistance: 0-10mA: 0-1.5KΩ; 4-20mA: 0-750Ω.
- Frequency output: bidirectional flow output. Frequency output is proportional to the flow percentage of the full range. The converter provides fully isolated transistor open collector frequency output ranged from 1 to 5000 Hz. The external DC power supply should not exceed 35V and maximum collector current is 250mA.
- Pulse output: bidirectional flow output. The converter can output up to 5000cp/s pulse series, which is dedicated to external totalization. Pulse factor is defined as volume or mass per pulse. It can be set to 0.001L/p, 0.01L/p, 0.1L/p, 1L/p, 2L/p, 5L/p, 10L/p, 100L/p, 1m<sup>3</sup>/p, 10 m<sup>3</sup>/p, 100 m<sup>3</sup>/p or 1000 m<sup>3</sup>/p. Pulse width is selectable from auto, 10ms, 20ms, 50ms, 100ms, 150ms, 200ms, 250ms, 300ms, 350ms and 400ms. Photo-coupler isolated transistor open collector circuit is used for pulse output. The external DC power supply should not exceed 35V and maximum collector current is 250mA.
- Flow direction indication: The converter is capable of measuring both forward and reverse flow and recognizing its direction. The converter outputs 0V low level for forward flow, while +12V high level for reverse flow.
- Alarm output: Two channels of photo-coupler isolated open collector circuit are used for alarm signal output. There are two alarm outputs: high limit alarm and low limit alarm. The external DC power supply should not exceed 35V and maximum collector current is 250mA.
- Damping constant: Damping time is selectable from 0.2 to 100s.

# Drawings and Dimensions

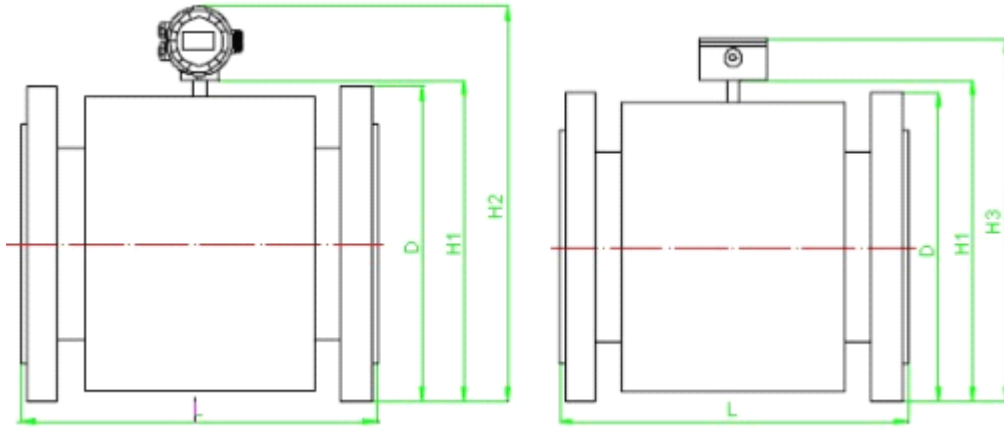

DN size	Nominal Pressure	Dimension(mm)					Weight	
		L	D	H1	H2	H3	Compact	Remote
15	4.0	200	95	155	285	215	7.5	8.5
20		200	105	160	290	220	8.5	9.5
25		200	115	165	295	225	9	10
32		200	140	180	310	240	10.5	11.5
40		200	150	190	320	250	11	12
50		200	165	200	330	260	13	14
65	2.5	250	185	220	350	280	15	16
80		250	200	240	370	300	17	18
100	1.6	250	235	250	380	310	19	20
125		250	270	280	410	340	23	24
150		300	300	320	450	380	28	29
200	1.0	350	340	380	510	440	36	37
250		450	395	430	560	490	51	52
300		500	445	490	620	550	71	72
350		500	505	550	680	610	82	83
400		500	565	600	730	660	99	100
450		550	615	640	770	700	114	115
500		550	670	700	830	760	134	135
600		600	780	800	930	860	164	165
700		0.6	700	860	895	1025	955	439
800	800		975	1015	1145	1075	549	550
900	900		1075	1115	1245	1175	659	660
1000	1000		1175	1230	1360	1290	814	815
1200	1200		1405	1450	1580	1510	879	880
1400	1400		1630	1630	1760	1690	1239	1240
1600	1600		1830	1830	1960	1890	1559	1560
1800	1800		2045	2045	2175	2105	2089	2090
2000	2000		2265	2265	2395	2325	2614	2615
2200	2200		2475	2475	2605	2535	3214	3215
2400	2400		2685	2685	2815	2745	3914	3915
2600	2600		2905	2905	3035	2965	4284	4285
2800	2800	3115	3115	3245	3175	5004	5005	
3000	3000	3315	3315	3445	3375	5604	5605	

---

## Lectotype principle

The measured fluid must be conducting liquid or slurry with a conductivity no less than  $5\mu\text{s}/\text{cm}$ , avoid fluid with too much ferromagnetic substance or bubble. The pressure rating, liner material, electrode material and instrument structure should be chosen based on the characteristics of the fluid.

### Selection of nominal diameter

1. As electromagnetic flowmeter has a high rangeability of 1500:1, the selection of nominal diameter is the same as that of process pipe;
2. If there are solid particle in the measured medium, a flow rate range of 1~3m/s is recommended. If the practical flow rate is excessive yet inconvenient to adjust, the nominal diameter of the instrument is better larger than that of the process pipe, under which condition the flow rate in the measuring pipe of the flowmeter can be properly decreased and the abrasion of electrode and liner caused by the particle can be alleviated;
3. If there are sediment in the process pipe, a flow rate range of 1~3m/s is recommended. If the practical flow rate is too little, the nominal diameter of the instrument is better smaller than that of the process pipe in order to properly increase the flow rate of the fluid in the flowmeter to avoid the effect on the accuracy caused by the sediment.
4. If the flow rate is too little yet a high-precision measurement is required, a sensor smaller than the nominal diameter can increase the flow rate to ensure high precision.

In the above 2,3,4 conditions, a reducing pipe should be jointed to both the upstream and downstream of the flowmeter. The centre taper angle should be no more than  $15^\circ$  and there should be a straight pipe at least 5 times of the the process pipe jointed to the reducing pipe.

To help making lectotype, several flow values which corresponding to the certain typical flow rate are listed in the table below, any flow value could be quickly work out based on the corresponding flow rate: If a flow value is known as  $Q(\text{m}^3/\text{h})$ , according to the relevant nominal diameter, check out the corresponding flow value  $Q_1$  with a flow rate of 1m/s, then the flow rate can be work out through a formula as  $V=Q/Q_1(\text{m}/\text{s})$ .



comparison table of flow and flowrate

Flow rate m/s Flow m <sup>3</sup> /h Diameter mm	0.01 (Min.)	1	2	3	4	5	15 (Max.)
15	0.0064	0.6362	1.2723	1.9085	2.5447	3.1809	9.5426
20	0.0113	1.1310	2.2619	3.3929	4.5239	5.6549	16.9646
25	0.0177	1.7671	3.5343	5.3014	7.0686	8.8357	26.5072
40	0.452	4.5239	9.0478	13.5717	18.0956	22.6195	67.8584
50	0.0707	7.0686	14.1372	21.2058	28.2743	35.3429	106.0288
65	0.1195	11.9459	23.8918	35.8377	47.7836	59.7295	179.1886
80	0.1810	18.0956	36.1911	54.2867	72.3823	90.4779	271.4336
100	0.2827	28.2743	56.5487	84.8230	113.0973	141.3717	424.1150
150	0.6362	63.6173	127.2345	190.8518	254.4690	318.0863	954.2588
200	1.1310	113.0973	226.1947	339.2920	452.3893	565.4867	1696.4600
250	1.7671	176.7146	353.4292	530.1438	706.8583	883.5729	2650.7188
300	2.5447	254.4690	508.9380	763.4070	1017.8760	1272.3450	3817.0351
350	3.4636	346.3606	692.7212	1039.0818	1385.4424	1731.8030	5195.4089
400	4.5239	452.3893	904.7787	1357.1680	1809.5574	2261.9467	6785.8401
450	5.7256	572.5553	1145.1105	1717.6658	2290.2210	2962.7763	8588.3289
500	7.0686	706.8583	1413.7167	2120.5750	2827.4334	3534.2917	10602.8752
600	10.1788	1017.8760	2035.7520	3053.6281	4071.5041	5089.3801	15268.1403
700	13.8544	1017.8760	2770.8847	4156.3271	5541.7694	6927.2118	20781.6354
800	18.0956	1385.4424	3619.1147	5428.6721	7238.2295	9047.7868	27143.3605
900	22.9022	1809.5574	4580.4421	6870.6631	9160.8842	11451.1052	34353.3157
1000	28.2743	2290.2210	5654.8668	8482.3002	11309.7336	14137.1669	42411.5008
1200	40.71.50	2827.4334	8143.0082	12214.5122	16286.0163	20357.5204	61072.5612
1400	55.4177	4071.5041	11083.5389	16625.3083	22167.0778	27708.8472	83126.5416
1600	72.3823	5541.7694	14476.4589	21714.6884	28952.9179	36191.1474	108573.4421
1800	91.6088	7238.2295	18321.7684	27482.6525	36643.5367	45804.4209	137413.2627
2000	113.0973	9160.8842	22619.4671	33929.2007	45238.9342	56548.6678	169646.0033
2200	136.8478	11309.7336	27369.5552	41054.3328	54739.1104	68423.8880	205217.6640
2400	162.8602	16286.0163	32572.0326	48858.0490	65144.0653	81430.0816	244290.2448
2600	191.1343	19113.4268	38226.8536	57340.2804	76453.7072	95567.1340	286701.4020

## Selection of liner material

Liner material	Main performances	Applicability
polytetrafluoro ethylene	<p>1.It is a plastic material with the stablest chemical properties, resist the corrosion of boiling hydrochloric acid, sulfuric acid, nitric acid, aqua regia, concentrated alkali and many kinds of organic solvent, unable to resist the corrosion of chlorine trifluoride, high temperature vanadyltrifluoride, high flow-rate liquid fluorine, liquid oxygen and ozon;</p> <p>2.Poor abrasion resistance;</p> <p>3.Poor ability of anti-negative pressure.</p>	<p>1.100°C , 150°C(special order required);</p> <p>2.Strong corrosive medium like concentrated acid , alkali, etc.;</p> <p>3.Sanitary medium.</p>
polychloroprene rubber	<p>1.Excellent elasticity, high degree of tensile strength, good wear resistance;</p> <p>2.Able to resist the corrosion of generally low concentration acid, alkali and salt, unable to resist that of the oxidative medium.</p>	<p>1.80°C,120°C(special order required);</p> <p>2.General water, polluted water, weak wear ability mud and ore pulp.</p>
polyurethane rubber	<p>1.Excellent wear resistance(ten times of the natural rubber's);</p> <p>2.Poor abrasion resistance of acid and alkali;</p> <p>3.Not able to work with water mixed with organic solvent.</p>	<p>1.&lt;80°C;</p> <p>2.Middle and strong wear ability ore pulp, coal pulp, mud, etc..</p>

## Selection of electrode material

Materials of electrode	Corrosion resistance
Mo-containing stainless steel (0Cr18Ni12Mo2Ti)	Able to work with medium with weak corrosivity, such as industrial water, living water, polluted water, etc., widely used in industries like oil, chemical, urea, vinylon, etc..
Stainless steel-coated wolfram carbide	Used for medium without corrosivity or with weak wear ability.
Hastelloy B(HB)	Good corrosion resistance of different concentration of hydrochloric acid under boiling point, resist the corrosion of non-oxidizing acid, alkali, non-oxidizing salt solution, such as sulfuric acid, phosphoric acid, organic acid, etc..
Hastelloy C(HC)	Resist the corrosion of oxidizing acid, such as nitric acid, mixed acid, the mixture of chromic acid and sulfuric acid, oxidizing salt like Fe <sup>+++</sup> , Cu <sup>++</sup> or other oxidants such as hypochlorite solution above ordinary temperature and seawater.

Titanium(Ti)	Resist the corrosion of seawater, all kinds of chloride, hypochlorite, oxidizing acid(include fuming nitric acid), organic acid, alkali, etc., unable to resist the corrosion of purer reducing acid like sulfuric acid and hydrochloric acid. The corrosivity of alpha hydroxy acids will be substantially decreased if there are oxidants such as nitric acid, Fe <sup>+++</sup> , Cu <sup>++</sup> , etc. in it.
Tantalum(Ta)	The corrosion resistance of tantalum is as good as glass. Except hydrofluoric acid, fuming nitric acid and alkali, it is able to resist the corrosion of almost any other chemical media.
Platinum-iridium alloy	Almost be able to work with any chemical medium other than aqua regia and ammonium salt.

As there is a great variety of medium and their corrosivity can be affected by complexity factors such as temperature, concentration, flow rate, etc., the above two tables are just for reference. Customers should make choices according to the practical situations, if necessary, corrosion resistance experiment like hanging sheet experiment of simulation materials should be performed.

## **Selection of liner protection flange and grounding flange**

Type of flange	Applicability
Grounding flange	Applicable to non-conductive pipeline like plastic pipeline. However, it is not required for the sensor with polytetrafluoroethylene liner.
Inlet protection flange	Applied when the medium has strong wear ability, often used with polyurethane liner. However, it is not applicable to the sensor with polytetrafluoroethylene liner.

# Converter Operation Menu and Parameter Setting

## 6.1 Keypad and Display

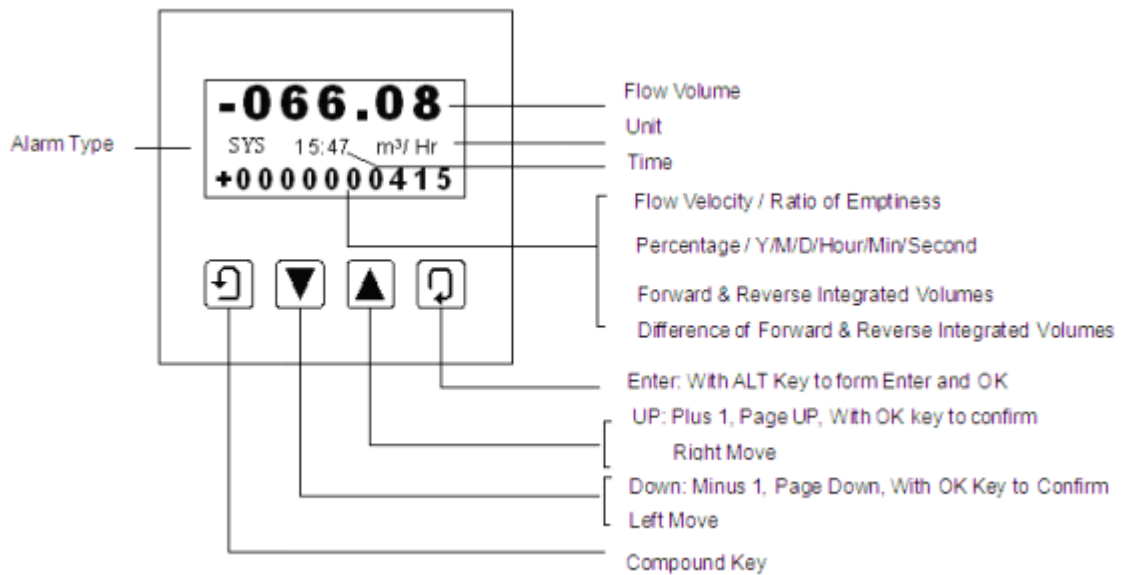

Fig.5(a) Remote-type key and display

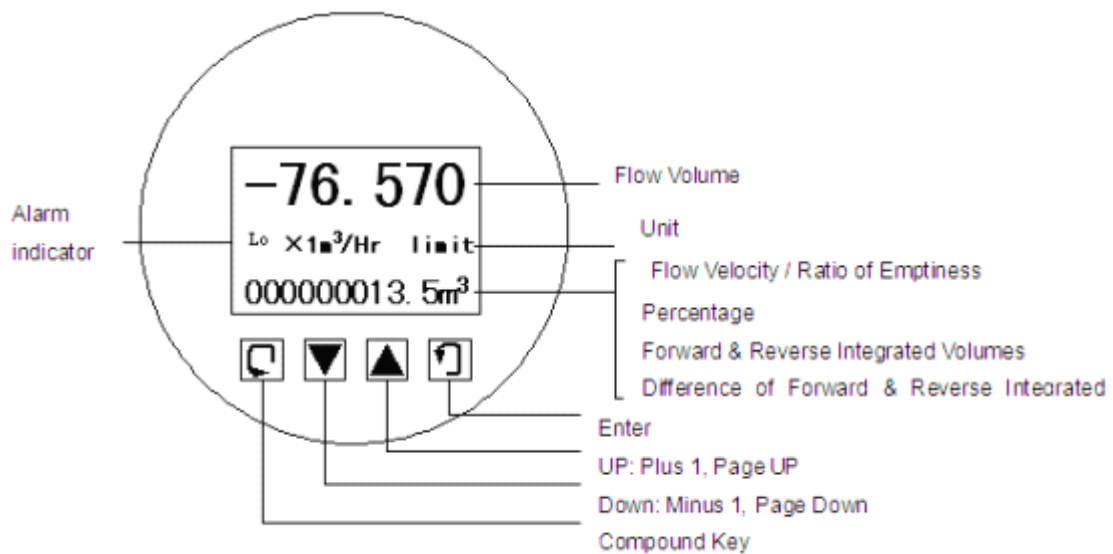

Fig.5(b) Compact-type key and display

## 6.2 L\_MagB\_4 key parameters and setting

When electrify, the instrument comes into measure way automatically, and under this way it can do all the functions and display data. Under the parameter setting way, user can set the parameter by the four keys.

### 5.2.1 Keys function

#### a) Keys' function in self- testing way

“Down” key: Selecting displayed data on lower line in turn;

“Up” key: Selecting displayed data on higher line in turn;

“Compound” key + “Enter” key: Come into parameter setting

“Enter” key: Press it to come into the picture of select function.

Under the measure, adjust of the LCD contract is used “Compound” key + “Up” key or “Compound” key + “Down” key for several seconds;

#### b) Function keys for parameters setting

“Down” key: Subtract 1 from the number at cursor area;

“Up” key: Plus 1 to the number at cursor area;

“Compound” key + “Down” key: Cursor turns left;

“Compound” key + “Up” key: Cursor turns right; “Enter” key: In/Out submenu;

“Enter” key: Press for two seconds under any state and will return to automate measure way.

Note: (1) When use “Compound” key, you should press “Compound” key and “Up” or

“Down” both;

(2) It will return to the measure way automatically after 3 minutes when under the parameter setting way;

(3) Direct select of zero correction about the flow, you can move the cursor to the left + or - , and use “Down” or “Up” to switch;

### 6.2.2 Function keys for setting parameters

To set or correct working parameters, the converter should be running in parameters setting way instead of measuring status. In measuring status, push “Compound”+“Enter” keys getting to the select of parameter and transfer password (0000), and then correct the password with one of the new passwords that are provided by manufacturer. Finally, push the “Compound”+“Enter” keys to work in Parameters Setting Way.

There are 6 Passwords in design and among them 4 for deferent operators in secret and 2 are fixed passwords for system operation.

### 6.2.3. Functions select menu

Push “Compound”+“Enter” keys to the functions select menu, push “Up” or “Down” keys to select, there are two functions:

Code	Functions	Notes
1	Parameters	Select this function; It can enter the

	Set	picture of parameter.
2	Clr Total Rec	Select this function, It can be gross reset operation.
3	Fact Modif Rec	Select this function, It can be check the factor 's modif Record

### 6.2.3.1 Parameters Set

Press “Compound”+“Enter” key, it displays “Parameters Set” function. Input password. Press “Compound”+“Enter” key, it getting to Parameters Setting status.

### 6.2.3.2 Clr Total Rec

To push “Compound”+“Enter” keys getting to the select of parameter, then push “Up” key to “Clr Total Rec”, input the passwords. When the passwords becomes “00000”, this function is done, the gross is 0 in the instrument.

### 6.2.3.3 Fact Modif Rec

To push “Compound”+“Enter” keys getting to the select of parameter, then push “Up” key to “Fact Modif Rec”(Detail consult the AppendixFive)

## 6.2.4 Setting Parameters in Menu

There are 54 parameters of L\_MagB, user can set every parameter. The List of Parameters is shown below:

Setting Parameters in Menu

Code	Parameter words	Setting Way	Grades	Range
1	Language	Select	2	English
2	Comm Adres	Set count	2	0~99
3	Baud Rate	Select	2	600~14400
4	Snsr Size	Select	2	3~3000
5	Flow Unit	Select	2	L/h、 L/m、 L/s、 m <sup>3</sup> /h、 m <sup>3</sup> /m、 m <sup>3</sup> /s
6	Flow Range	Set count	2	0~99999
7	Flow Rspns	Select	2	1~50
8	Flow Direct	Select	2	Plus/ Reverse
9	Flow Zero	Set count	2	0~±9999
10	Flow Cutoff	Set count	2	0~599.99%
11	Cutoff Ena	Select	2	Enable/Disable
12	Total Unit	Select	2	0.001m <sup>3</sup> ~1m <sup>3</sup> 、 0.001L~1L、
13	SegmaN Ena	Select	2	Enable/Disable
14	Analog Type	Select	2	0~10mA /4~20mA
15	Pulse Type	Select	2	Freque / Pulse
16	Pulse Fact	Select	2	0.001m <sup>3</sup> ~1m <sup>3</sup> 、 0.001L~1L、
17	Freque Max	Select	2	1~ 5999 HZ

18	Mtsnsr Ena	Select	2	Enable/Disable
19	Mtsnsr Trip	Set count	2	59999 %
20	Alm Hi Ena	Select	2	Enable/Disable
21	Alm Hi Val	Set count	2	000.0 ~ 599.99 %
22	Alm Lo Ena	Select	2	Enable/Disable
23	Alm Lo Val	Set count	2	000.0 ~ 599.99 %
24	Sys Alm Ena	Select	2	Enable/Disable
25	Clr Sum Key	Set count	3	0 ~ 99999
26	Snsr Code1	User set	4	Finished Y M
27	Snsr Code2	User set	4	Product number
28	Field Type	Select	4	Type1,2,3
29	Sensor Fact	Set count	4	0.0000 ~ 5.9999
30	Line CRC Ena	Select	4	Enable/Disable
31	Lineary CRC1	User set	4	Set Velocity
32	Lineary Fact 1	User set	4	0.0000 ~ 1.9999
33	Lineary CRC2	User set	4	Set Velocity
34	Lineary Fact 2	User set	4	0.0000 ~ 1.9999
35	Lineary CRC3	User set	4	Set Velocity
36	Lineary Fact 3	User set	4	0.0000 ~ 1.9999
37	Lineary CRC4	User set	4	Set Velocity
38	Lineary Fact4	User set	4	0.0000 ~ 1.9999
39	FwdTotal Lo	Correctable	5	00000 ~ 99999
40	FwdTotal Hi	Correctable	5	00000 ~ 9999
41	RevTotal Lo	Correctable	5	00000 ~ 99999
42	RevTotal Hi	Correctable	5	00000 ~ 9999
43	PlsntLmtEna	Select	5	Enable/Disable
44	PlsntLmtVal	Select	5	0.010 ~ 0.800m/s
45	Plsnt Delay	Select	5	400 ~ 2500ms
46	Pass Word 1	User correct	5	00000 ~ 99999
47	Pass Word 2	User correct	5	00000 ~ 99999
48	Pass Word 3	User correct	5	00000 ~ 99999
49	Pass Word 4	User correct	5	00000 ~ 99999
50	Analog Zero	Set count	5	0.0000 ~ 1.9999
51	Anlg Range	Set count	5	0.0000 ~ 3.9999
52	Meter Fact	Set count	5	0.0000 ~ 5.9999
53	MeterCode 1	Factory set	6	Finished Y /M
54	MeterCode 2	Factory set	6	Product Serial No

Parameters of converters can decide the running status, process and output ways as well as state of output. Correct option and setting of

parameters can keep the converters running optimally and get higher accuracies of output both in display and in measurement.

There are 6 grades of passwords for setting parameters function. Grades 1 to grade 5 of passwords are for users and grade 6 of password is for manufacturer. Users can reset their passwords of grades 1~4 in grade 5.

Users can check converters parameters in any grade of password. However, if users want to change parameters of converters, different grade of parameters have to be used by the users.

Grade 1 of password (set by manufacturer as 00521): users can only read parameter.

Grade 2 of password (set by manufacturer as 03210): users can change 1~24 parameters.

Grade 3 of password (set by manufacturer as 06108): users can change 1~25 parameters.

Grade 4 of password (set by manufacturer as 07206): users can change 1~38 parameters.

Grade 5 of password (Fixed): users can change 1~52 parameters.

Password Grade 5 can be set by skilled users. Grade 4 is mainly used for resetting total volume in password. Grades 1~3 can be set by any one who can be chosen by users.

## 6.3 Details Parameters

### 6.3.1 Language

There are 2 languages for L\_MagB converter operation. They can be set by users according to the users needs.

### 6.3.2 Comm Address

It means this instrument's address when communicates with many, and has 01~99, holding the 0.

### 6.3.3 Baud Rate

600, 1200, 2400, 4800, 9600, 19200, baud rate.

### 6.3.4 Snsr Size

L\_MagB converters can be equipped with some different sensors that have different diameter of measuring pipes. The pipes in different diameters from 3mm to 3000mm can be chosen in relative table.

### 6.3.5 Flow unit

The flow unit can choose from the parameters (L/s, L/m, L/h, m<sup>3</sup>/s, m<sup>3</sup>/m, m<sup>3</sup>/h), and the user can choose the proper unit according to the technological requirement and using habit.

### 6.2.6 Flow Range

Flow range means upper limit value, and lower limit value is set "0" automatically. So, it makes the range, and makes the relation of percent display, frequency output and current output with flow:

percent display = ( flow measure / measure range) \* 100 %;

frequency output = ( flow measure / measure range) \* frequency full;



current output = ( flow measure / measure range) \* current full + base point;

pulse output will not affect.

### 6.3.7 Flow Rspns

It means time of filter measure value. The long one can enhance the stability of flow display and output digital, and fits for gross add up of pulse flow; the short one means fast respond rate, and fits for production control. It is set by select.

### 6.3.8 Flow Direct

If users think the direct and design are differ, just change the direct parameter is OK, but not change exciting or signal.

### 6.3.9 Flow zero

Make sure the sensor is full of flow, and the flow is stillness. Flow zero is shown as velocity of flow, mm/s.

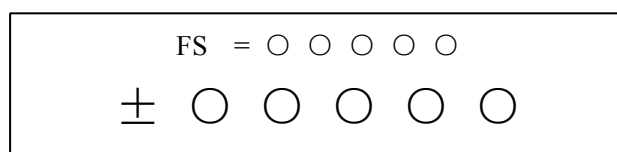

Converter's zero-flow correction displays like

this:

Upper small words: FS means measure value of zero;

Lower large words: correction value of zero.

When FS is not "0", make FS = 0. Note: if change the value on next line and FS increases, please change the "+, -" to correct FS to zero.

Flow zero is the compound value of the sensor, and should be recorded in sensor list and band. The unit will be mm/s, and the sign will be opposite with correction value.

### 6.3.10 Flow cutoff

Flow cutoff is set in percentage of Upper Limit Range of flow, and users can delete all Negligible Small Signals of flow volume, velocity and percentage out of displaying and outputting them. Sometimes user can delete output of current output signal and frequency (pulse) output signal only to have flow, velocity and percentage being displayed

### 6.3.11 Total Unit

Converter display is counter with 9 bits, and the max is 999999999.

Integrator units are L, m<sup>3</sup> (liter, stere,).

Flow integrator value: 0.001L、 0.010L、 0.100L、 1.000L  
0.001m<sup>3</sup>、 0.010m<sup>3</sup>、 0.100m<sup>3</sup>、 1.000m<sup>3</sup>;

### 6.3.12 SegmaN Ena

When "SegmaN Ena" is "enable", if the flow flows, the sensor will export pulse and current. When it is "disable", the sensor will export pulse as "0" and current as "0"(4mA or 0mA) for the flow flows reversals.

### 6.3.13 Output currents

Output current types can be chosen by users as 1~10mA or 4~20mA

practically.

#### 6.3.14 Pulse Type

Two kinds of Pulse Outputs are can be chosen: Frequency Output and Pulse Output. Frequency Output is continuous square waveform and Pulse output is a serial wave of square wave. Frequency output is mainly used for instant flow and total integrated flow in short time measurement. Frequency output can be chosen in equivalent frequency unit and volume of integrated flow can be displayed. Frequency Output can be used in long time measurement for total integrated flow with volume units.

Frequency output and pulse output are usually from OC gates so that DC power supplies and load resistors have to be required (See Part 4.5).

#### 6.3.15 Pulse Fact

Equivalent pulse Unit is referred to one pulse for value of flow. The range of pulse equivalent can be chosen:

Pulse Equivalent	Flow	Pulse Equivalent	Flow
1	0.001L/cp	5	0.001m <sup>3</sup> /cp
2	0.01L/cp	6	0.01m <sup>3</sup> /cp
3	0.1L/cp	7	0.1m <sup>3</sup> /cp
4	1.0L/cp	8	1.0m <sup>3</sup> /cp

Under the same flow, the smaller pulse, the higher frequency output, and the smaller error will be. The highest pulse output is 100cp/s, and mechanism electromagnetic counter can get 25 frequency/s.

#### 6.3.16 Freque Max

Frequency output range is as the upper limit of flow measure, just the percent flow 100%. Frequency output upper limit can be selected between 1~5000Hz.

The state of empty pipe can be detected with the function of converter. In the case of Empty Pipe Alarm, if the pipe was empty, the signals of analog output and digital output would be zero and displayed flow would be zero, too.

#### 6.3.17 Mtsnsr Ena

The state of empty pipe can be detected with the function of converter. In the case of Empty Pipe Alarm, if the pipe was empty, the signals of analog output and digital output would be zero and displayed flow would be zero, too.

#### 6.3.18 Mtsnsr Trip

When the pipe is full of liquid (whether flowing or not), the parameter of "Mtsnsr" could be modified more easily. The parameter displayed upper line is real MTP, and the parameter displayed bellow is the "Mtsnsr trip" that should be set. When setting "Mtsnsr trip", you could be according to the real MTP, the value that should be set is usually three to five times of real MTP.

#### 6.3.19 Alm Hi Ena

Users can choose "Enable" or "Disable".

#### 6.3.20 Alm Hi Val

The parameter of upper limit alarm is percentage of flow range and can be set in the way of setting one numerical value between 0%~199.9%.When the value of flow percentage is larger than the value of setting value, the converter outputs the alarm signal.

#### 6.3.21 Alm Lo Val

The same as upper limit alarm.

#### 6.3.22 Sys Alm Ena

Selecting Enable will have the function, and selecting Disable will cancel the function.

#### 6.3.23 Clr Sum Key

User use more than 3 byte code to enter ,Then set this password in Clr Total Rec.

#### 6.3.24 Snsr Code

It is referred to the produced date of sensor and the serial number of product that can keep the sensors coefficient right and accurate.

#### 6.3.25 Sensor Fact

“Sensor Coefficient” is printed on the Label of the sensor when it is made in factory. The “sensor coefficient” has to be set into Sensor Coefficient Parameter when it runs with converter.

#### 6.3.26 Field Type

L\_MagB affords three exciting frequency types: 1/16 frequency (type 1), 1/20frequency (type 2), 1/25 frequency (type 3)。 The small-bore one should use 1/16 frequency, and large-bore one should use 1/20 or 1/25 frequency. When using, please select type 1 first, if the zero of velocity is too high, select the type 2 or type 3.

Note: Demarcate on which exciting type, working on it only.

#### 6.3.27 FwdTotal Lo、 hi

Positive total volume high byte and low byte can change forthcoming and reverse total value, and be used to maintenance and instead.

User use 5 byte code to enter, and can modify the positive accumulating volume ( $\Sigma+$ ). Usually, it is unsuitable to exceed the maximum the counter set (999999999) .

#### 6.3.28 RevTotal Lo、 hi

User use 5 byte code to enter, and can modify the negative accumulating volume ( $\Sigma-$ ). Usually, it is unsuitable to exceed the minimum the counter set (999999999) .

#### 6.3.29 PlsntLmtEn

For paper pulp, slurry and other serosity, the flow measure will have "cuspidal disturb", because the solid grain friction or concussion the measure electrode. L\_MagB converters use variation restrain arithmetic to conquer the disturbing by designing three parameters to select disturb character.

Set it "enable", start variation restrain arithmetic; set it "disable", close variation restrain arithmetic.

### 6.3.30PlsntLmtVI

This coefficient can disturb the variation of cuspidal disturb, and calculate as percent of flow velocity, thus ten grades: 0.010m/s, 0.020m/s, 0.030m/s, 0.050m/s, 0.080m/s, 0.100m/s, 0.200m/s, 0.300m/s, 0.500m/s, 0.800m/s, and the smaller percent, the higher delicacy of cuspidal restrain.

Note: when using it, must test for select by the fact, and sometimes it is not the higher delicacy is good.

### 6.3.31 PlsntDelay

This coefficient can select the width of time of restrain cuspidal disturb and the unit is ms. If the duration is shorter than flow change in some time, L\_MagB will think it is cuspidal disturb, and if it is longer, L\_MagB will think it is natural. It also needs to select parameter in fact.

### 6.3.32User's password 1~4

Users can use 5 grades of passwords to correct these passwords.

### 6.3.33 Analog Zero

When the converters are made in the factory, output current has been calibrated to zero scale, that is, accurate 0mA or 4mA output.

### 6.3.34 Anlg Range

When the converters is made in the factory, output current have been calibrated to full scale, that is, accurate 10mA or 20mA output.

### 6.3.35Meter Fact

This fact is the special one of sensor-made-factory and the factory use this fact to unite L\_MagB electromagnetic flowmeters converters to make sure all the instruments can interchange by 0.1%.

### 6.3.36 MeterCode 1 and 2

Converter code records the date of manufacturing and serial number of converter

# Installation

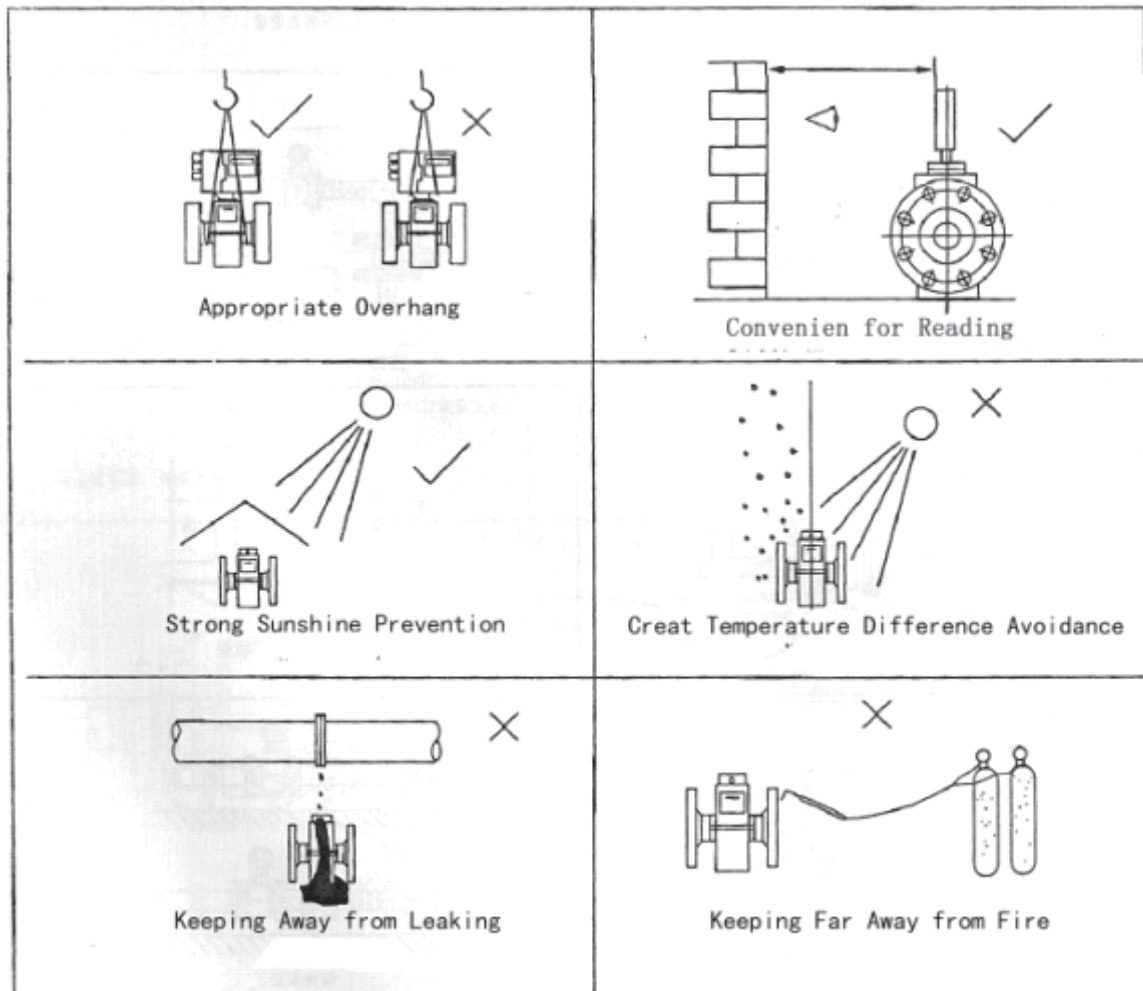

The correct installation flowmeter

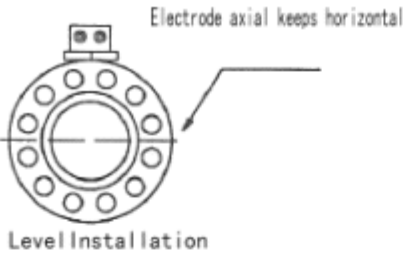
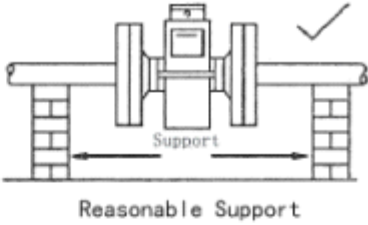
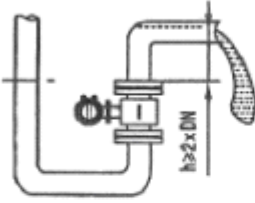
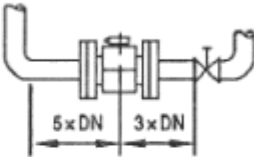
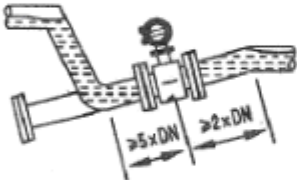
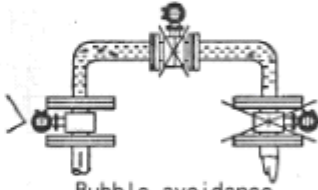
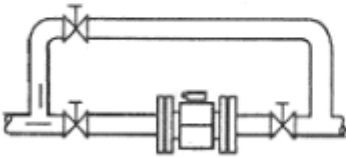
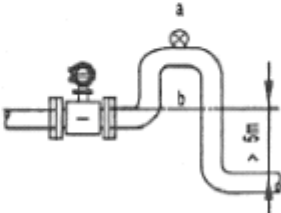
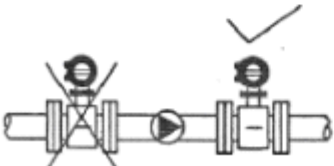
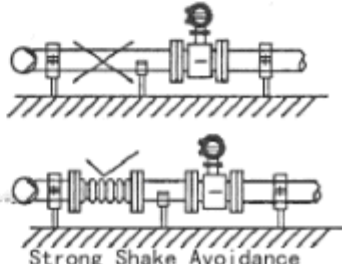
 <p>Electrode axial keeps horizontal</p> <p>Level Installation</p>	 <p>Support</p> <p>Reasonable Support</p>
 <p>Full of Pipe</p>	 <p>5 × DN 3 × DN</p> <p>Ensure the Requir. of the Straight Pipe section</p>
 <p>Measurement for the Precipitable</p>	 <p>Bubble avoidance</p>
 <p>Easy to Maintenance and Clean-up</p>	 <p>Negative Pressure and Non-filled pipe Avoidance</p>
 <p>Not Installed in Front of the Inlet of Pump</p>	 <p>Strong Shake Avoidance</p>

## 8.1 Grounding

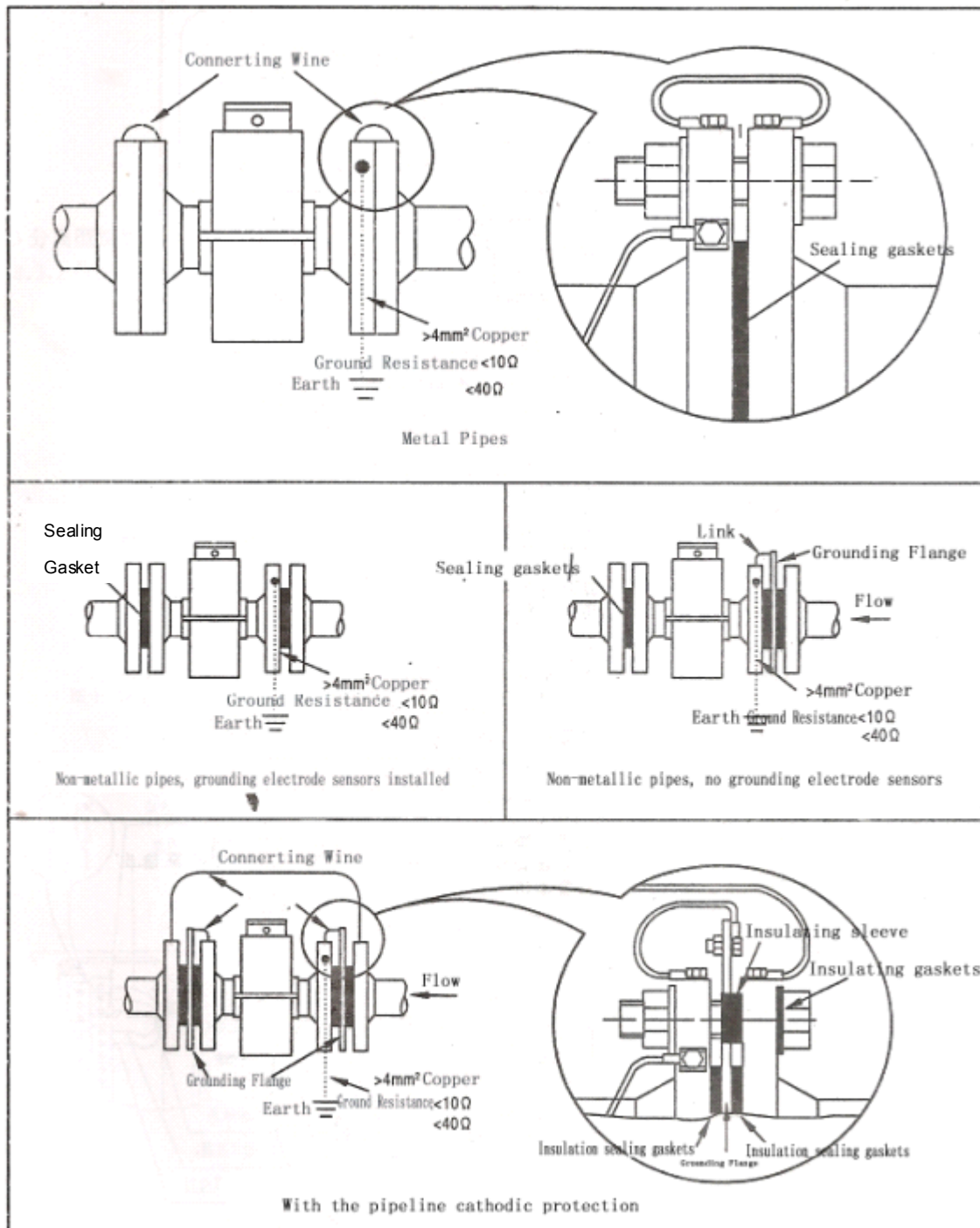

## 8.2 Converter Terminals and Definition

Terminal blocks and marks are shown in Fig. 8 and Fig. 9

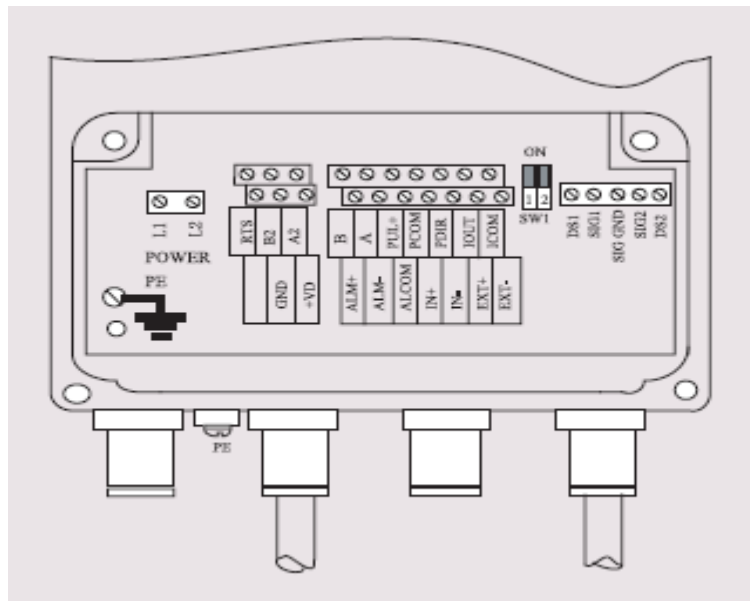

Fig. 8 Remote Type: Terminals and Marks

The definition of terminals and their marks for remote type converter is given as below:

DS1	Shield drive 1
SIG1	Signal input 1
SIG GND	Signal Ground
SIG2	Signal input 2
DS2	Shield drive 2
EXT+	Coil excitation +
EXT-	Coil excitation -
IOUT	Current output +
ICOM	Current output -
PUL+	Frequency/pulse output +
PCOM	Frequency/pulse output -
PDIR	Flow direction indicator +
ALM-	Low alarm output +
ALM+	High alarm output +
ALCOM	Alarm output -
A	RS485 communication A
B	RS485 communication B
IN+	Input contact +
IN-	Input contact -
L1(+)	220V(24V +) input
L2(-)	220V(24V -) input

The dip switch SW1 is set to ON to supply +12V power to pulse output. If



external power is used, turn the switch to OFF.

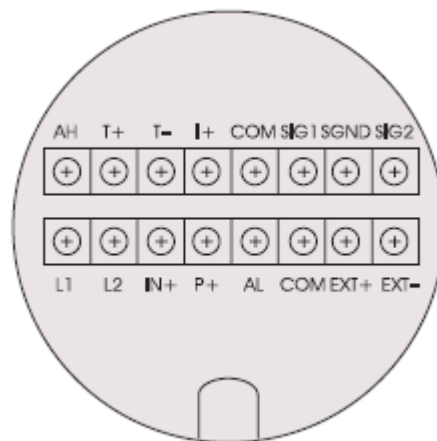

Fig. 9 Compact Type: Terminals and Marks

The definition of terminals and their marks for compact type converter is given as below:

T -	RS485-B
T+	RS485-A
COM	Alarm/flow direction/ pulse output -
FDIR	Flow direction indicator +
AL	Low alarm output +
AH	High alarm output +
IN-	Input contact -
IN+	Input contact +
P+	Frequency/pulse output +
COM	Current/pulse output -
I+	Current output +
L1(+)	220V(24V +) input
L2(-)	220V(24V -) input

## 8.3 Remote-type Wiring

### 8.3.1 Terminal Block in Sensor

Fig. 11 Marks of Terminal Block

SIG1: Signal 1 (Connecting to white coax wire of STT3200 cable)

SIG2: Signal 2 (Connecting to black coax wire of STT3200 cable)

DS1: Signal 1 shield drive (Connecting to inner shield layer of white coax wire of STT3200 cable)

DS2: Signal 2 shield drive (Connecting to inner shield layer of black coax wire of STT3200 cable)

SIG GND: Signal ground (Connecting to Ex-shield of STT3200 cable)

EXT+: Coil 1 (Connecting to red cable)

EXT-: Coil 2 (Connecting to yellow cable)

### 8.3.2 Connection of STT3200 Cable

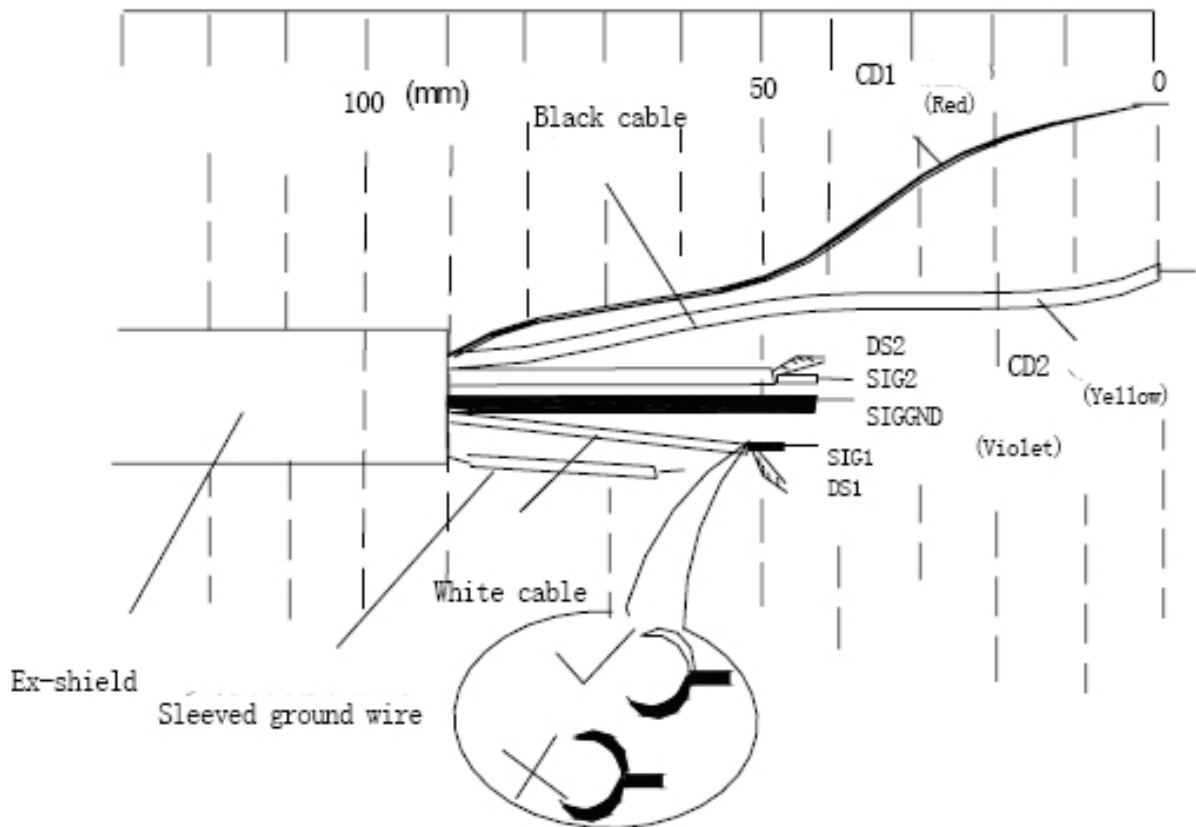

STT3200 Schematic Diag for Cable Preparation

Fig. 13 Schematic Diag for STT3200 Cable Preparation

## 8.4 Output Signal Wiring

The dip switch SW1 is set to ON to supply +12V power to pulse output. A 1K $\Omega$  resistor is connected to the +12V power to provide a pull-up. If external power is used, turn the switch to OFF.

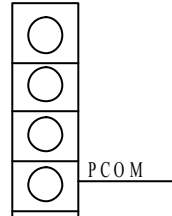
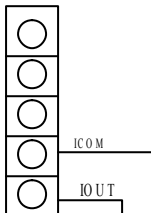

Fig. 14(a) Wiring of current output

Fig.14 (b) Example of electromagnetic counter connection

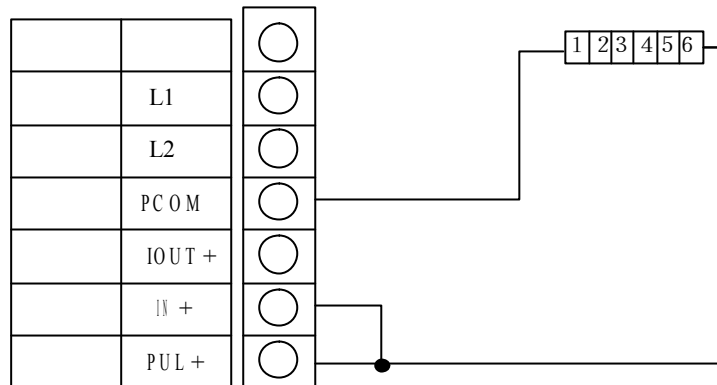

Fig. 14(c) Example of electrical counter connection

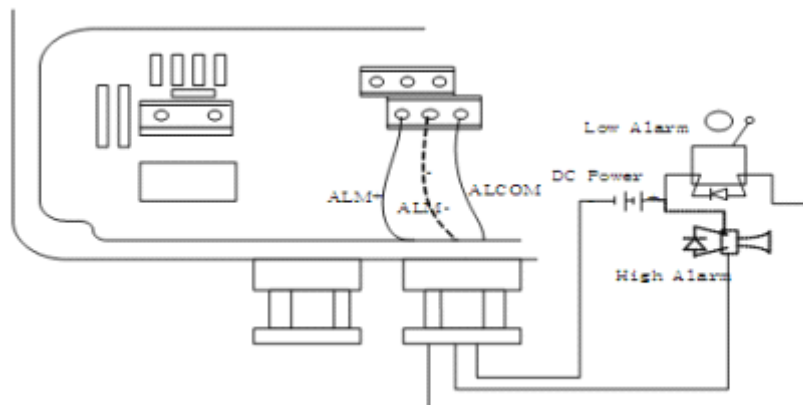

Fig. 14(d) Digital Output Direct Connection

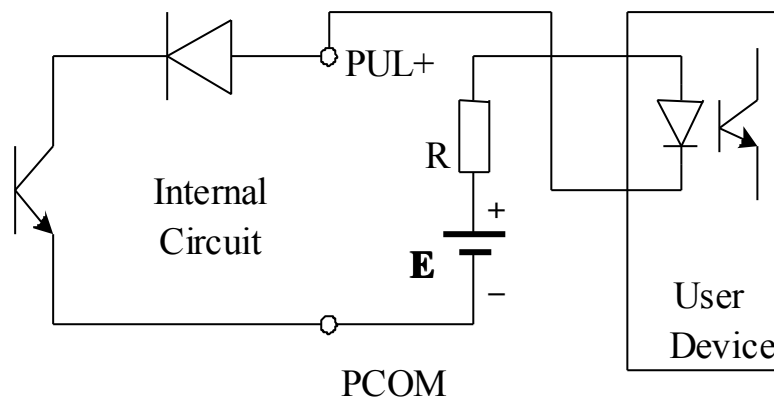

Fig. 14(e) Connection with photo-coupler (e.g. PLC)

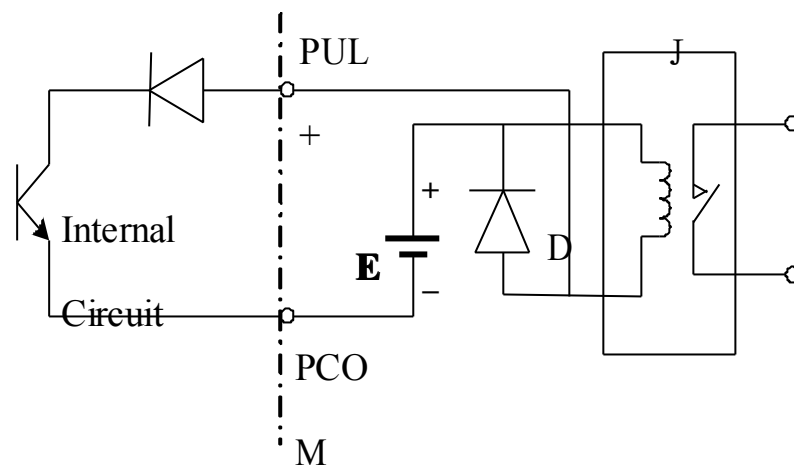

Fig.14 (f) Connection with relay (e.g. PLC)

Generally, the intermediate relay needs 12V or 24V power supply E. D is a surge-absorbing diode, which is usually embedded in the relay. If not, an external one is necessary.

---

## Self-diagnostic and Troubleshooting

The converter is made by surface mount technology and is not repairable for user. Do not open the converter case.

The self-diagnosis function of the converter is capable of displaying alarm information except power supply or hardware failures. A '!' symbol is displayed on the right corner of LCD top-line and malfunction information can be read from the bottom-line by pressing DOWN key. User may check the flowmeter according to the alarm information. Some examples of alarms are given below:

**Coil Alm**  
**Elctrd Alm**  
**EpPipe Alm**  
**Low Alarm**  
**High Alarm**

Troubleshooting information is given below:

### 9.1 No display

- a) Check the connection of power supply;
- b) Check fuse;
- c) Check the voltage of power supply;
- d) Check if the LCD contrast can be adjusted. Adjust it if possible;
- e) Return to base, if a) to d) are OK.

### 9.2 Coil Alarm

- a) Check if terminal EXT+ and EXT- are open;
- b) Check if coil resistance is less than 150Ω;
- c) Replace converter if a) and b) are OK.

### 9.3 Empty Pipe Alarm and Electrodes Alarm

- a) Check if the sensor pipe is filled with fluid;
- b) Check the connection of signal wiring;
- c) Connect the terminal SIG1, SIG2 and SIG GND. If the alarm display disappears, it is confirmed the converter is normal. The alarm may be caused by the bubble in the fluid;
- d) For electrodes alarm, measure the resistance between two electrodes with a multimeter. The read should be between 3 to 50kΩ. Otherwise, the electrodes are contaminated or covered.

### 9.4 High Alarm

Increase the flow range.

### 9.5 Low Alarm

Reduce the flow range.

### 9.6 Inaccurate Measurement

- a) Check if the sensor pipe is filled with the fluid to be measured.

- b) Check the wiring;
- c) Check if the sensor factor and flow zero are the same as those on the calibration sheet.

## Packing

The package includes:  
The electromagnetic flowmeter ordered;  
Instruction Manual;

## Transportation and Storage

To prevent the flowmeter from damage in the transportation, the package should be kept in unopened status before reaching installation site. The storage room should be satisfied with the following conditions:

- a. Rain-proof, humidity-proof;
- b. Strong Vibration and Shake Avoidance
- c. Temperature between  $-20$  to  $+60^{\circ}\text{C}$ , relative humidity less than 80%

## Operation

Before operation, the following inspection should be done to check if:

- a. There is any damage caused by transportation or installation;
- b. The power used is same as the label on the flowmeter;
- c. The wiring is correct.

After inspection, turn the valve on to fill the pipe up and make sure there is no leakage and the gas inside the pipe is eliminated. Switch on the power supply and the flowmeter is ready to use after 10 minutes warm-up.

If there is any problem, please refer to the Section 9 for troubleshooting. If still not working properly, contact the manufacturer immediately.