



Heating technology since 1959

User Manual ***for model***

RS 32



Wall mounted heating only boiler
room sealed chamber

INDEX

1. <u>General warning</u>	<u>pagina 1</u>
2. <u>Control Panel</u>	<u>pagina 2</u>
3. <u>Starting up the boiler</u>	<u>pagina 3</u>
4. <u>INFO Menu</u>	<u>pagina 3</u>
5. <u>Boiler functioning modes</u>	<u>pagina 4</u>
6. <u>Filling the system</u>	<u>pagina 5</u>
7. <u>Diagnostics – Error codes</u>	<u>pagina 5</u>
8. <u>Switching OFF the boiler</u>	<u>pagina 6</u>
9. <u>Frost Protection</u>	<u>pagina 6</u>
10. <u>Maintenance</u>	<u>pagina 7</u>
11. <u>Recycling</u>	<u>pagina 7</u>

BOILER OPERATING INSTRUCTIONS

1. General warning

-  Make sure that the authorised technician who tested the boiler has stamped the guarantee booklet.
-  The installation, first start-up, regulation and maintenance operations must be carried out exclusively by qualified personnel (e.g. Radiant authorised Service Centres). Incorrect installation can cause damage to property and injury to persons or animals, for which the manufacturer will not be held responsible.

During the installation, the technician must carry out the following checks:

- *The data on the data plate must correspond to that of the mains supply networks (gas, electricity, water);*
- *The boiler must be regulated according to its designed use and performance;*
- *The flue gas exhaust and combustion air intake system must be correctly installed and operational;*
- *The exhaust gas discharge and ventilation systems must comply with the requirements of national and local standards regardless of whether the boiler is installed indoors, outdoors or in its own cabinet (see section "Reference standards").*

User general warnings:

- *If there is any doubt as to whether the appliance has been tested by an authorised technician, do not attempt to start it. All maintenance and gas conversion operations **MUST BE CARRIED OUT BY PROFESSIONALLY QUALIFIED PERSONNEL.***
- *Should any part of the boiler freeze-up, do not attempt to light it under any circumstances, but instead call the Service Centre immediately.*
- *The appliance's combustion system must be checked every two years. This check includes testing the efficiency of the boiler and must be carried out by authorised personnel possessing the qualifications as required by current law.*
- *Do not obstruct the ventilation openings in rooms where there are gas-burning appliances installed (boiler, cooker, etc.)*
- *Do not allow the appliance to be used by persons (including children) with reduced physical, sensory, mental capabilities or with lack of experience and knowledge unless they have been viewed or educated on the use of the appliance by the person responsible for its safety or anyone unfamiliar with its operation;*
- *The installation, operation and maintenance manual forms an integral and essential part of the product and must be kept near the appliance always.*

If you smell gas ...

- ➔ ***DO NOT ACTIVATE ANY ELECTRIC SWITCHES, TELEPHONES OR ANY OTHER DEVICE THAT MAY GENERATE ELECTRICAL DISCHARGES OR SPARKS.***
- ➔ ***OPEN DOORS AND WINDOWS IMMEDIATELY TO CREATE A CURRENT OF AIR THAT WILL RAPIDLY CLEAR THE ROOM.***
- ➔ ***CLOSE ALL GAS TAPS AND VALVES.***
- ➔ ***CALL FOR PROFESSIONALLY QUALIFIED PERSONNEL.***

2. Control Panel

CONTROL PANEL KEY

1. **HEATING TEMPERATURE SETTING BUTTONS**
2. **INFO BUTTON:** PRESS ONCE TO DISPLAY TEMPERATURES AND INFO (see 2.8 INFO menu display); KEEP IT PRESSED FOR 5 SECONDS (IN OFF MODE) TO DISPLAY THE LAST 5 ERRORS.
3. **MODE SELECTION BUTTON:** WINTER ONLY / OFF.
4. **RESET BUTTON:** ERROR RESET – FLUE TEST FUNCTION ACTIVATION (CHIMNEY-SWEEPER - KEEP IT PRESSED FOR 7 SECONDS)
5. **PARAMETERS VALUE SETTING BUTTONS**
6. TERMINAL BLOCK FOR EXTERNAL WIRING
7. LCD DISPLAY.

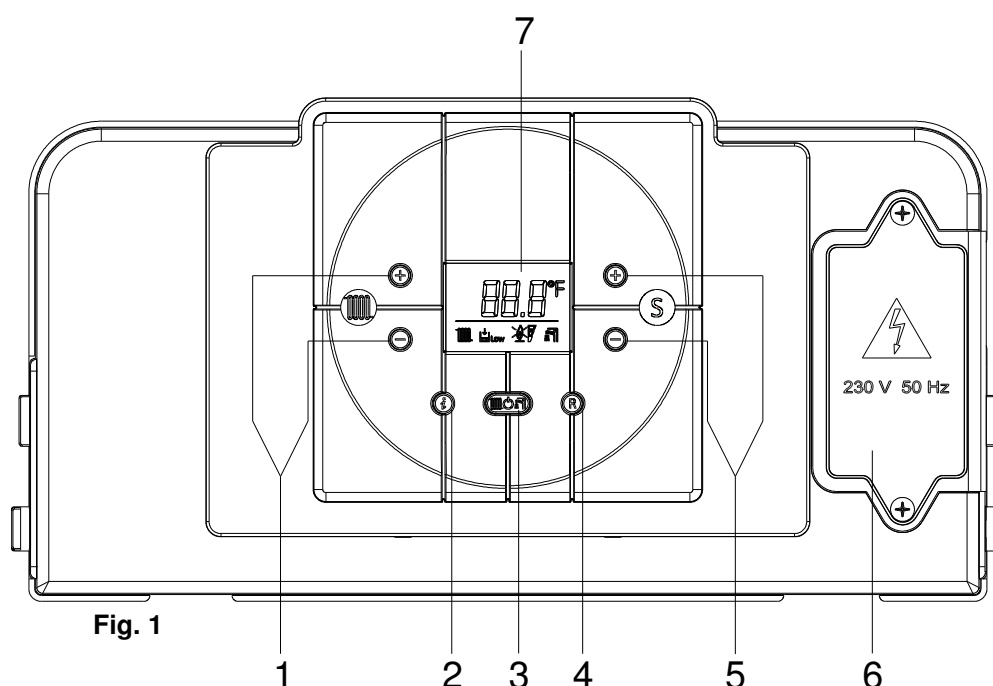

During the boiler operation the display can show 2 different power levels according to the flame modulation of the boiler (see fig. 2)

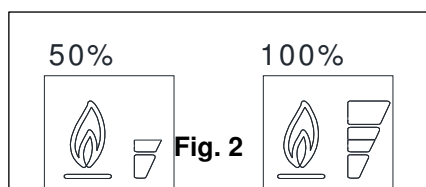



3. Starting up the boiler

- Check that the boiler is power supplied and that the gas feed valve, placed at the bottom of the boiler, is open.
- Switch on the boiler by using MODE SELECTION BUTTON  and select the functioning mode required.

4. INFO Menu

Press the '  ' INFO Button to display the boiler data.

Once pressed, the parameter number will appear on the left side of the display and the associated parameter value will appear on the centre of the display. Use '  ' and '  ' buttons of  Heating Temperature setting to scroll the list of available data.



Press the '  ' INFO button to exit the display mode.

The list of available display data is the following:

Parameter	Description
d01	Outdoor temperature sensor
d02	Kd Thermoregulation value
d03	Low temperature circuit sensor (only with Zone PCB connected)

5. Boiler functioning modes

“WINTER” mode

To switch boiler operation to “WINTER” mode, press the MODE SELECTION button  ('3' – fig. 1); The boiler will only work for the Heating system. The “WINTER” mode setting of the boiler is signalled by the symbol  lit continuously on the control panel.

The automatic ignition system will light the burner every time there is a room heating demand. In this case, the symbol  will flash on the control panel.

Regulating the heating temperature

The heating temperature is regulated by using ‘+’ and ‘-’ buttons of  Heating temperature setting ('1' – fig. 1):

- Pressing ‘-’ button, reduces the temperature.
- Pressing ‘+’ button, increases the temperature.

The range of temperature settings for the central heating runs from a minimum of 30°C to a maximum of 80°C (25 °C – 45 °C for under floor heating systems).

6. Filling the system

In order to restore the water pressure of the system, open the filling tap **R** (fig. 2) and check by means of a pressure gauge **M**, that the pressure of the system reaches the middle part of the green zone (which corresponds to 1,2 bar, see fig. 3).

On completion, close the filling tap R (fig.2).

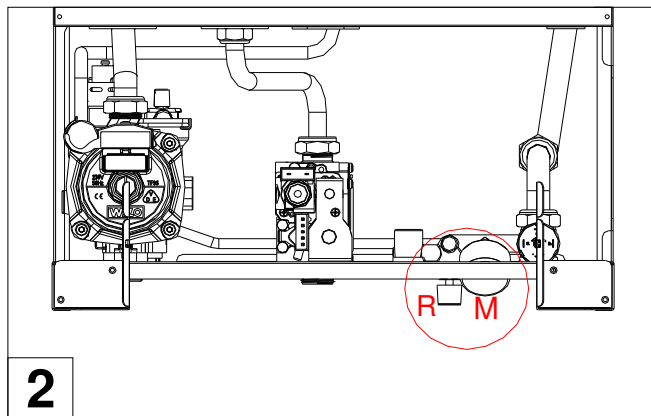

7. Diagnostics – Error codes

This paragraph contains a list of error codes that the boiler may generate on the display together with the relative indications and the operations that the user can carry out to reset the boiler.

Code **E01** Ionisation malfunction

- Check that the gas valve on the boiler and gas meter are open. and that there is gas in the mains supply.
- Press Reset button ‘**R**’ on the control panel to reset the error;
- When the error code on the display disappears, the boiler will restart automatically.

⚠ If the problem persists, **Call the Service Centre.**

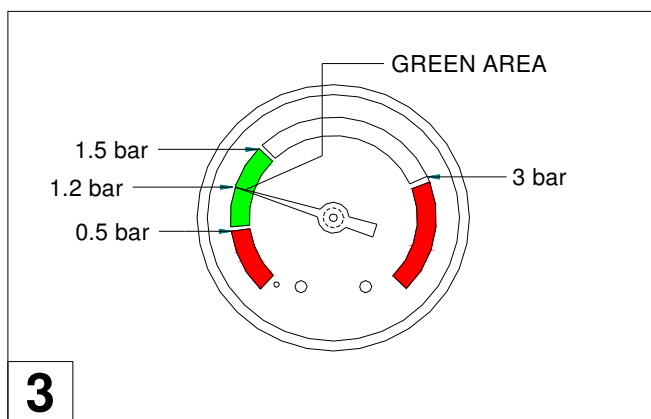

Code **E02** Safety Thermostat tripped.

- Press Reset button ‘**R**’ on the control panel to reset the error;
- When the error code on the display disappears, the boiler will restart automatically.

⚠ If the problem persists, **Call the Service Centre.**

Code **E03** Air Pressure Switch Tripped. **Call the Service Centre.**

Code **E04** Water Pressure Switch Tripped (Low).

- Check the water pressure in the central heating circuit. The reading on the pressure gauge **M** (see fig. 2), located on the lower part of the boiler, must not be less than 1,2 bar.
- If the pressure is less than 1,2 bar, top-up the system as described in paragraph “Filling the system”.
- When the error code on the display disappears, the boiler will restart automatically.

⚠ If the problem persists, **Call the Service Centre.**

Code **E05** Heating Sensor malfunction. **Call the Service Centre.**

Code **E18** Inadequate circulation. **Call the Service Centre.**

Code **E21** General malfunction inside the printed circuit board.

- Switch off the power supply at the main switch and then switch it on again;
- When the error code on the display disappears, the boiler will restart automatically.

 If the problem persists, **Call the Service Centre.**

Code **E22** Parameter programming request.

- Switch off the power supply at the main switch and then switch it on again;
- When the error code on the display disappears, the boiler will restart automatically.

 If the problem persists, **Call the Service Centre.**

Code **E35** Flame detection malfunction.

- Press Reset button '  ' on the control panel to reset the error;
- When the error code on the display disappears, the boiler will restart automatically.

 If the problem persists, **Call the Service Centre.**

Code **E40** Electric power supply out of the operation range. **Call the Service Centre.**

Code **F08** Frost protection function (central heating circuit) ON. **Wait for the completion of the operation.**

8. Switching OFF the boiler

→ To switch the boiler OFF, press  **INFO** button, the word **OFF** appears on the display. The central heating frost protection system remains enabled.

→ If the boiler was previously ON, it is switched OFF and the fan overrun and pump overrun functions are enabled.

N.B. If the boiler is to be left unused for a long period of time, the user must do one of the following:

- *Make the boiler safe* by disconnecting all the power supplies (electricity and gas), and draining the heating system;
- Leave the boiler in *standby*, leaving the electricity and gas supplies connected and, consequently the frost protection function.

9. Frost Protection

The boiler is protected from freezing by electronic board settings and special functions that provide the starting of the burner to heat all the interested parts, when their temperature drops below the minimum preset values.

This function is enabled if:

- the boiler is electrically power supplied;
- the gas supply is open;
- the system pressure is that required;
- the boiler is not locked out.

 **In case of boiler parts locked out because of freezing, do not switch the boiler ON and immediately call the Service Centre.**

10. Maintenance

In order to ensure that the boiler operates efficiently and safely, it is recommended that the appliance is inspected by a suitably competent technician at least once a year.

A regular maintenance is always source in management system savings.

11. Recycling

The appliance packaging is mainly made of recyclable materials.

The appliance and all its accessories must be disposed of appropriately differentiated in compliance with the relevant standards.

	<p>The symbol indicates the inability to dispose of this product as domestic waste.</p> <p>The correct disposal of this product will help to prevent potential negative consequences for the environment and people health.</p>
---	---



Heating technology since 1959

RADIANT BRUCIATORI s.p.a.

Via Pantanelli, 164/166 - 61025 Loc. Montelabbate (PU)

Tel. +39 0721 9079.1 • fax. +39 0721 9079279

e-mail: info@radiant • Internet: <http://www.radiant.it>

THE TECHNICAL DATA AND MEASUREMENTS ARE PROVIDED FOR INFORMATION PURPOSES ONLY AND ARE NOT BINDING. THE COMPANY RESERVES THE RIGHT TO APPLY VARIATIONS WITHOUT PRIOR NOTIFICATION. NEITHER WILL THE COMPANY BE HELD RESPONSIBLE FOR ANY INACCURACIES IN THIS HANDBOOK DERIVING FROM PRINTING OR TRANSLATION ERRORS. ALL RIGHTS RESERVED. NO PART OF THIS DOCUMENT MAY BE REPRODUCED, MEMORISED IN ANY FILING SYSTEMS OR TRANSMITTED IN ANY FORM WHATSOEVER, INCLUDING ELECTRONIC, MECHANICAL, PHOTOCOPIES, RECORDINGS OR ANY OTHER MEANS WITHOUT THE COMPANY'S PRIOR WRITTEN APPROVAL.