

# STANLEY®

## BR87 HYDRAULIC BREAKER



### USER MANUAL Safety, Operation and Maintenance



© 2014 Stanley Black & Decker, Inc.  
New Britain, CT 06053  
U.S.A.  
65778 7/2014 Ver. 11

# DECLARATION OF CONFORMITY

DECLARATION OF CONFORMITY  
 ÜBEREINSTIMMUNGS-ERKLÄRUNG  
 DECLARATION DE CONFORMITE CEE  
 DECLARACION DE CONFORMIDAD  
 DICHIARAZIONE DI CONFORMITA



I, the undersigned:  
 Ich, der Unterzeichnende:  
 Je soussigné:  
 El abajo firmante:  
 Io sottoscritto:

**Weisbeck, Andy**

Surname and First names/Familiennamen und Vornamen/Nom et prénom/Nombre y apellido/Cognome e nome

hereby declare that the equipment specified hereunder:  
 bestätige hiermit, daß erklaren Produkt genannten Werk oder Gerät:  
 déclare que l'équipement visé ci-dessous:  
 Por la presente declaro que el equipo se especifica a continuación:  
 Dichiaro che le apparecchiature specificate di seguito:

1. Category: **Hydraulic Hand Held Concrete Breaker**  
 Kategorie:  
 Catégorie:  
 Categoria:  
 Categoría:

2. Make/Marke/Marque/Marca/Marca **Stanley**

3. Type/Typ/Type/Tipo/Tipo: **BR8713201, BR8717201, BR87320**

4. Serial number of equipment:  
 Seriennummer des Geräts:  
 Numéro de série de l'équipement:  
 Numero de serie del equipo:  
 Matricola dell'attrezzatura:

**BR8713201 All**  
**BR8717201 All**  
**BR87320 Serial # 031312004 and above**

5. Mass/Masse/Masse/Masa/Massa 38 kg

Has been manufactured in conformity with  
 Wurde hergestellt in Übereinstimmung mit  
 Est fabriqué conformément  
 Ha sido fabricado de acuerdo con  
 E' stata costruita in conformità con

Directive/Standards Richtlinie/Standards Directives/Normes Directriz/Los Normas Direttiva/Norme	No. Nr Numéro No n.	Approved body Prüfung durch Organisme agréé Aprobado Collaudato
ISO Noise Directive	11148-4:2010 2000/14/EC:2005	Self AkustikNet (Notified body ID 1585) Bagsvard Hovedgade 141, 2880 Bagsvard, Denmark Certificate #863/2011/005
Machinery Directive ISO	2006/42/EC:2006 28927-10:2011	Self Self

6. Special Provisions: **None**  
 Spezielle Bestimmungen:  
 Dispositions particulières:  
 Provisiones especiales:  
 Disposizioni speciali:

7. Measurements: **Measured Sound Power Level 105 LwA**  
**Guaranteed Sound Power Level 106 LwA**  
 Messungen  
 Mesures  
 Mediciones  
 Misurazioni  
 Measured in accordance to Directive 2000/14/EC,  
 Annex III, Part B, No 10, m ≥ 30

8. Representative in the Union: **Patrick Vervier, Stanley Dubuis 17-19, rue Jules Berthonneau-BP 3406 41034 Blois Cedex, France.**  
 Vertreter in der Union/Représentant dans l'union/Representante en la Union/Rappresentante presso l'Unione

Done at/Ort/Fait à/Dado en/Fatto a Stanley Hydraulic Tools, Milwaukie, Oregon USA Date/Datum/le/Fecha/Data 1-30-12

Signature/Unterschrift/Signature/Firma Andy Weisbeck

Position/Position/Fonction/Cargo/Posizione Engineering Manager

# TABLE OF CONTENTS

DECLARATION OF CONFORMITY .....	2
SAFETY SYMBOLS .....	4
SAFETY PRECAUTIONS.....	5
TOOL STICKERS & TAGS .....	7
HOSE TYPES.....	8
HOSE RECOMMENDATIONS .....	9
FIGURE 1. TYPICAL HOSE CONNECTIONS .....	9
HTMA REQUIREMENTS.....	10
OPERATION.....	11
TOOL PROTECTION & CARE .....	12
TROUBLESHOOTING .....	13
CHARGING THE ACCUMULATOR.....	14
FIGURE 2. CHARGING THE ACCUMULATOR.....	15
SPECIFICATIONS.....	16
ACCESSORIES.....	17
SERVICE TOOLS .....	17
BR87 PARTS ILLUSTRATION .....	18
BR87 PARTS LIST .....	20
UNDERWATER TOOLS DEPTH GUIDELINE.....	21

## IMPORTANT

To fill out a Product Warranty Recording form, and for information on your warranty, visit [Stanleyhydraulics.com](http://Stanleyhydraulics.com) and select the Company tab, Warranty.  
**(NOTE:** The warranty recording form must be submitted to validate the warranty).

**SERVICING:** This manual contains safety, operation, and routine maintenance instructions. Stanley Hydraulic Tools recommends that servicing of hydraulic tools, other than routine maintenance, must be performed by an authorized and certified dealer. Please read the following warning.

## ⚠ WARNING

**SERIOUS INJURY OR DEATH COULD RESULT FROM THE IMPROPER REPAIR OR SERVICE OF THIS TOOL.**

**REPAIRS AND / OR SERVICE TO THIS TOOL MUST ONLY BE DONE BY AN AUTHORIZED AND CERTIFIED DEALER.**

For the nearest authorized and certified dealer, call Stanley Hydraulic Tools at the number listed on the back of this manual and ask for a Customer Service Representative.

# SAFETY SYMBOLS

Safety symbols and signal words, as shown below, are used to emphasize all operator, maintenance and repair actions which, if not strictly followed, could result in a life-threatening situation, bodily injury or damage to equipment.



This is the safety alert symbol. It is used to alert you to potential personal injury hazards. Obey all safety messages that follow this symbol to avoid possible injury or death.



This safety alert and signal word indicate an imminently hazardous situation which, if not avoided, will result in death or serious injury.



This safety alert and signal word indicate a potentially hazardous situation which, if not avoided, could result in death or serious injury.



This safety alert and signal word indicate a potentially hazardous situation which, if not avoided, could result in death or serious injury.



This signal word indicates a potentially hazardous situation which, if not avoided, may result in property damage.



This signal word indicates a situation which, if not avoided, will result in damage to the equipment.

This signal word indicates a situation which, if not avoided, may result in damage to the equipment.

Always observe safety symbols. They are included for your safety and for the protection of the tool.

## LOCAL SAFETY REGULATIONS

Enter any local safety regulations here. Keep these instructions in an area accessible to the operator and maintenance personnel.

---

---

---

---

---

---

---

---

---

---

---

---

---

---

---

---

---

---

---

---

---

---

---

---

# SAFETY PRECAUTIONS

Tool operators and maintenance personnel must always comply with the safety precautions given in this manual and on the stickers and tags attached to the tool and hose.

These safety precautions are given for your safety. Review them carefully before operating the tool and before performing general maintenance or repairs.

Supervising personnel should develop additional precautions relating to the specific work area and local safety regulations. If so, place the added precautions in the space provided in this manual.

The BR87 Hydraulic Breaker will provide safe and dependable service if operated in accordance with the instructions given in this manual. Read and understand this manual and any stickers and tags attached to the tool and hoses before operation. Failure to do so could result in personal injury or equipment damage.



- Operator must start in a work area without bystanders. The operator must be familiar with all prohibited work areas such as excessive slopes and dangerous terrain conditions.
- Establish a training program for all operators to ensure safe operation.
- Do not operate the tool unless thoroughly trained or under the supervision of an instructor.
- Always wear safety equipment such as goggles, gloves, ear, head, and breathing protection, and safety shoes at all times when operating the tool.
- Do not inspect, carry or clean the tool while the hydraulic power source is connected. Accidental engagement of the tool can cause serious injury.
- Supply hoses must have a minimum working pressure rating of 2500 psi/175 bar.
- Be sure all hose connections are tight.
- The hydraulic circuit control valve must be in the "OFF" position when coupling or uncoupling the tool. Wipe all couplers clean before connecting. Use only lint-free cloths. Failure to do so may result in damage to the quick couplers and cause overheating of the hydraulic system.
- Do not operate the tool at oil temperatures above 140 °F/60 °C. Operation at higher oil temperatures can cause operator discomfort and may damage the tool. Never come in contact with the tool bit, the bit can get hot.
- Do not operate a damaged, improperly adjusted, or incompletely assembled tool.
- Do not weld, cut with an acetylene torch, or hard-face the tool bit.
- To avoid personal injury or equipment damage, all tool repair, maintenance and service must only be performed by authorized and properly trained personnel.
- Do not exceed the rated limits of the tool or use the tool for applications beyond its design capacity.
- Always keep critical tool markings, such as labels and warning stickers legible.
- Always replace parts with replacement parts recommended by Stanley Hydraulic Tools.
- **Warning:** Use of this tool on certain materials during demolition could generate dust potentially containing a variety of hazardous substances such as asbestos, silica or lead. Inhalation of dust containing these or other hazardous substances could result in serious injury, cancer or death. Protect yourself and those around you. Research and understand the materials you are cutting. Follow correct safety procedures and comply with all applicable national, state or provisional health and safety regulations relating to them, including, if appropriate arranging for the safe disposal of the materials by a qualified person.

## SAFETY PRECAUTIONS

- Check fastener tightness often and before each use daily.
- Never operate the tool if you cannot be sure that underground utilities are not present.
- Do not wear loose fitting clothing when operating the tool.
- Warning: Hydraulic fluid under pressure could cause skin injection injury. If you are injured by hydraulic fluid, get medical attention immediately.
- Keep all body parts away from the working tool.
- When handling material or the tool bit, wear your (PPE) Personal Protection Equipment.
- Be observant of the hydraulic hoses lying about the work area, they can be a tripping hazard.
- Always de-energize the hydraulic system when changing a tool bit.
- Take caution when changing a tool bit, tool bits can get very hot.
- Never use the tool in an explosive atmosphere, sparks from the breaking process could ignite explosive gas.
- Use proper lifting techniques when handling the tool, get help from a co-worker and do not over-reach.
- Use proper protection from falling or flying debris, keep bystanders at a safe distance.
- Do not exceed the rated flow and pressure. See Specifications in this manual for correct flow rate and pressure rating. Rapid failure of the internal seals may result.

# TOOL STICKERS & TAGS



28409  
Composite Decal



11207  
Circuit Type C Decal

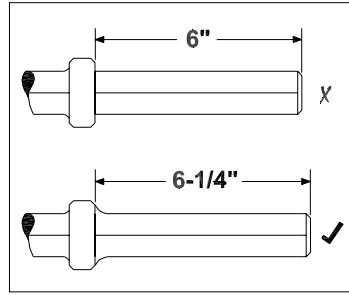

11208  
Hex Shank Decal

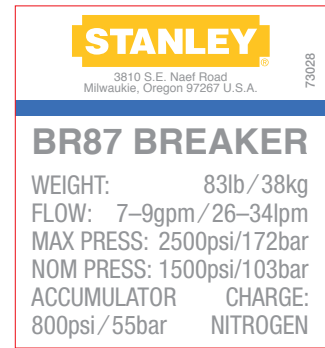

73028  
BR87 Name Tag Decal



28322  
CE Decal

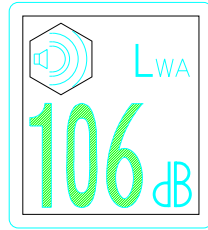

72786  
Guaranteed Sound Power  
Level Decal



10180  
Caution Decal

BR87 BREAKER  
WEIGHT: 83lb/38kg  
FLOW: 7-9gpm/26-34lpm  
MAX PRESS: 2500psi/172bar  
NOM PRESS: 1500psi/103bar  
ACCUMULATOR CHARGE:  
800psi/55bar NITROGEN

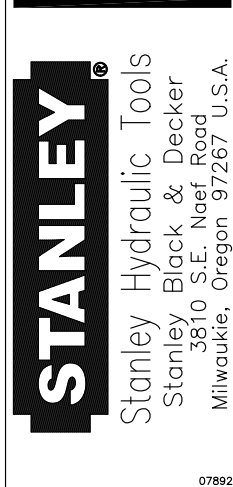

07892  
BR87 Name Tag Decal  
(Model BR87120D &  
BR87320 Only)

The safety tag (P/N 15875) at right is attached to the tool when shipped from the factory. Read and understand the safety instructions listed on this tag before removal. We suggest you retain this tag and attach it to the tool when not in use.

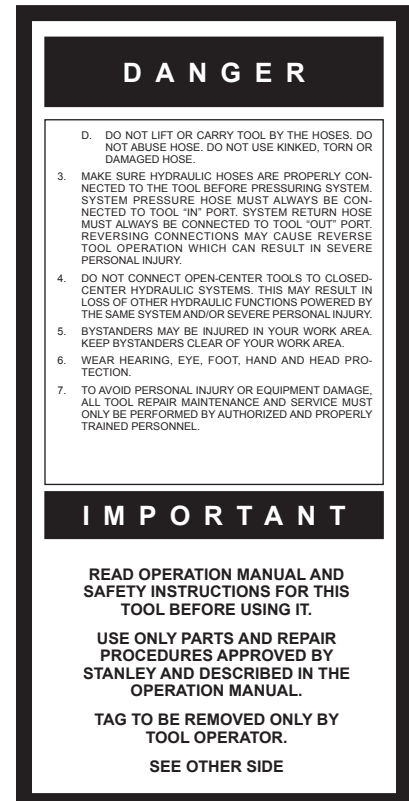
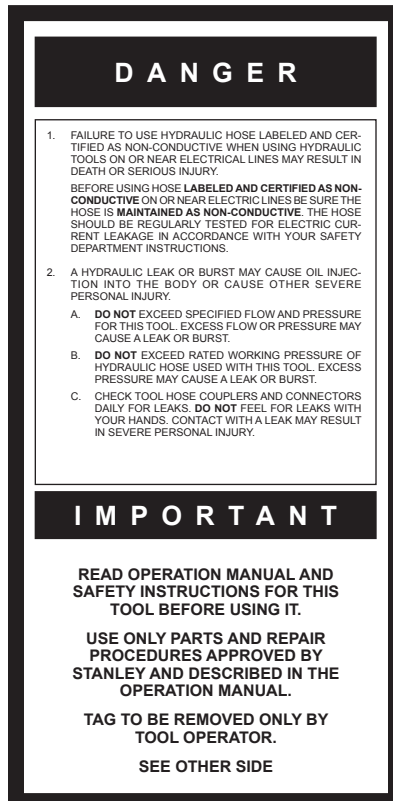

SAFETY TAG P/N 15875 (Shown smaller than actual size)

# HOSE TYPES

The rated working pressure of the hydraulic hose must be equal to or higher than the relief valve setting on the hydraulic system. There are three types of hydraulic hose that meet this requirement and are authorized for use with Stanley Hydraulic Tools. They are:

**Certified non-conductive** — constructed of thermoplastic or synthetic rubber inner tube, synthetic fiber braid reinforcement, and weather resistant thermoplastic or synthetic rubber cover. *Hose labeled **certified non-conductive** is the only hose authorized for use near electrical conductors.*

**Wire-braided** (conductive) — constructed of synthetic rubber inner tube, single or double wire braid reinforcement, and weather resistant synthetic rubber cover. *This hose is **conductive** and must never be used near electrical conductors.*

**Fabric-braided** (not certified or labeled non-conductive) — constructed of thermoplastic or synthetic rubber inner tube, synthetic fiber braid reinforcement, and weather resistant thermoplastic or synthetic rubber cover. *This hose is **not certified non-conductive** and must never be used near electrical conductors.*

## HOSE SAFETY TAGS

To help ensure your safety, the following DANGER tags are attached to all hose purchased from Stanley Hydraulic Tools. **DO NOT REMOVE THESE TAGS.**

If the information on a tag is illegible because of wear or damage, replace the tag immediately. A new tag may be obtained from your Stanley Distributor.

### THE TAG SHOWN BELOW IS ATTACHED TO “CERTIFIED NON-CONDUCTIVE” HOSE

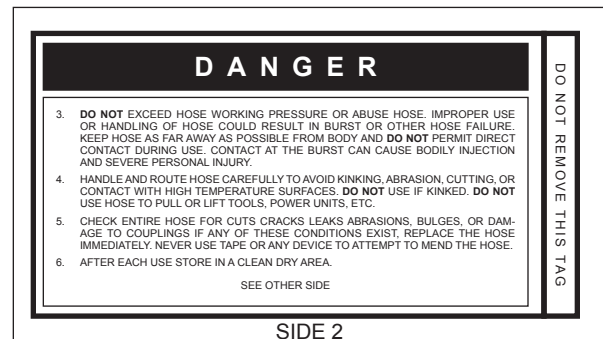
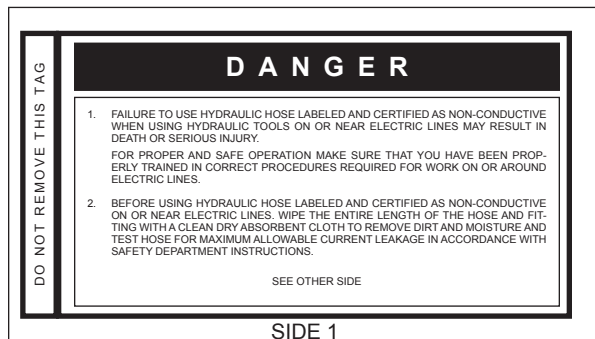

(Shown smaller than actual size)

### THE TAG SHOWN BELOW IS ATTACHED TO “CONDUCTIVE” HOSE.

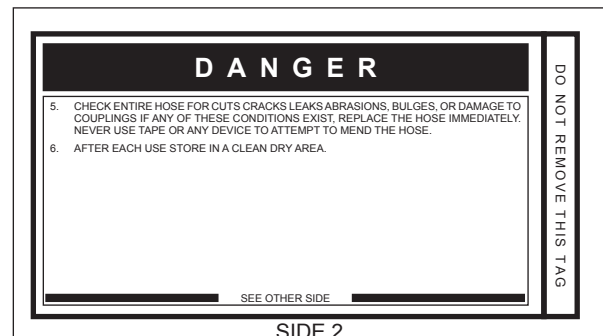
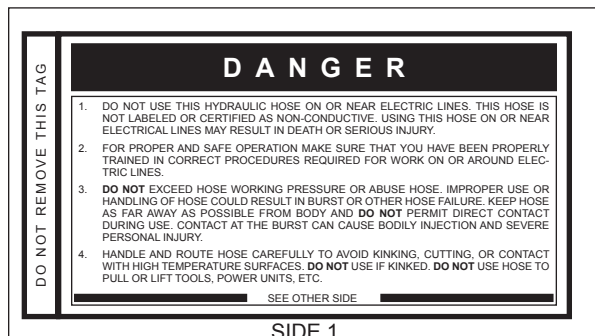

(Shown smaller than actual size)



# HOSE RECOMMENDATIONS

## Tool to Hydraulic Circuit Hose Recommendations

The chart to the right shows recommended minimum hose diameters for various hose lengths based on gallons per minute (gpm)/liters per minute (lpm). These recommendations are intended to keep return line pressure (back pressure) to a minimum acceptable level to ensure maximum tool performance.

This chart is intended to be used for hydraulic tool applications only based on Stanley Hydraulic Tools tool operating requirements and should not be used for any other applications.

All hydraulic hose must have at least a rated minimum working pressure equal to the maximum hydraulic system relief valve setting.

**All hydraulic hose must meet or exceed specifications as set forth by SAE J517.**

Oil Flow		Hose Lengths		Inside Diameter		USE (Press/Return)	Min. Working Pressure	
GPM	LPM	FEET	METERS	INCH	MM		PSI	BAR
<b>Certified Non-Conductive Hose - Fiber Braid - for Utility Bucket Trucks</b>								
4-9	15-34	up to 10	up to 3	3/8	10	Both	2250	155
<b>Conductive Hose - Wire Braid or Fiber Braid - DO NOT USE NEAR ELECTRICAL CONDUCTORS</b>								
4-6	15-23	up to 25	up to 7.5	3/8	10	Both	2500	175
4-6	15-23	26-100	7.5-30	1/2	13	Both	2500	175
5-10.5	19-40	up to 50	up to 15	1/2	13	Both	2500	175
5-10.5	19-40	51-100	15-30	5/8	16	Both	2500	175
5-10.5	19-40	100-300	30-90	5/8	16	Pressure	2500	175
10-13	38-49	up to 50	up to 15	3/4	19	Return	2500	175
10-13	38-49	51-100	15-30	5/8	16	Both	2500	175
10-13	38-49	100-200	30-60	3/4	19	Pressure	2500	175
13-16	49-60	up to 25	up to 8	5/8	16	Pressure	2500	175
13-16	49-60	26-100	8-30	3/4	19	Return	2500	175
				1	25.4	Return	2500	175
				5/8	16	Pressure	2500	175
				3/4	19	Return	2500	175
				3/4	19	Pressure	2500	175
				1	25.4	Return	2500	175

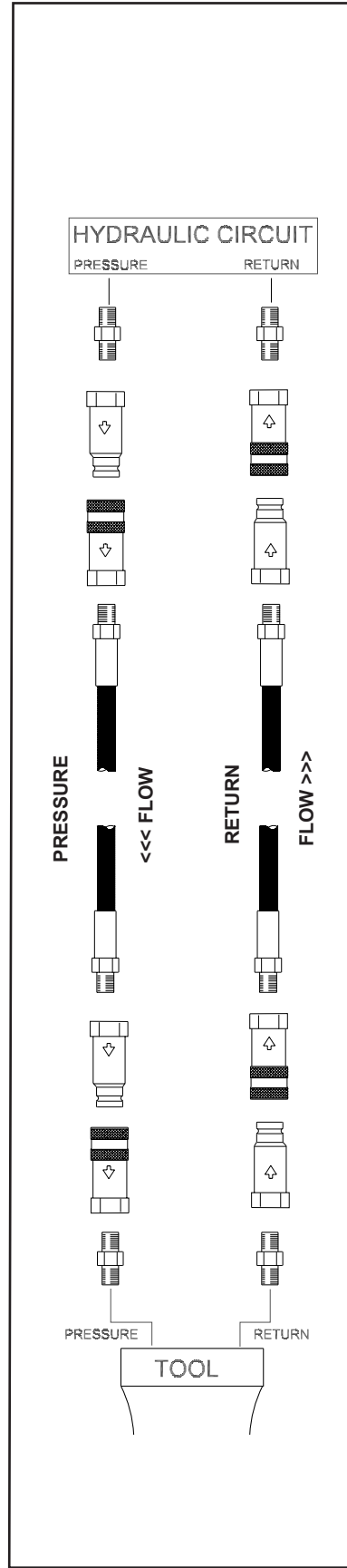

Figure 1. Typical Hose Connections

# HTMA / EHTMA REQUIREMENTS

## HTMA / EHTMA REQUIREMENTS

### HTMA





#### HYDRAULIC SYSTEM REQUIREMENTS

#### TOOL TYPE

	TYPE I	TYPE II	TYPE RR	TYPE III
Flow Range	4-6 gpm (15-23 lpm)	7-9 gpm (26-34 lpm)	9-10.5 gpm (34-40 lpm)	11-13 gpm (42-49 lpm)
Nominal Operating Pressure (at the power supply outlet)	1500 psi (103 bar)	1500 psi (103 bar)	1500 psi (103 bar)	1500 psi (103 bar)
System relief valve setting (at the power supply outlet)	2100-2250 psi (145-155 bar)	2100-2250 psi (145-155 bar)	2200-2300 psi (152-159 bar)	2100-2250 psi (145-155 bar)
Maximum back pressure (at tool end of the return hose)	250 psi (17 bar)	250 psi (17 bar)	250 psi (17 bar)	250 psi (17 bar)
Measured at a max. fluid viscosity of: (at min. operating temperature)	400 ssu* (82 centistokes)	400 ssu* (82 centistokes)	400 ssu* (82 centistokes)	400 ssu* (82 centistokes)
Temperature: Sufficient heat rejection capacity to limit max. fluid temperature to: (at max. expected ambient temperature)	140° F (60° C)	140° F (60° C)	140° F (60° C)	140° F (60° C)
Min. cooling capacity at a temperature difference of between ambient and fluid temps	3 hp (2.24 kW) 40° F (22° C)	5 hp (3.73 kW) 40° F (22° C)	6 hp (5.22 kW) 40° F (22° C)	7 hp (4.47 kW) 40° F (22° C)
<b>NOTE:</b> Do not operate the tool at oil temperatures above 140° F (60° C). Operation at higher temperatures can cause operator discomfort at the tool.				
Filter Min. full-flow filtration Sized for flow of at least: (For cold temp. startup and max. dirt-holding capacity)	25 microns 30 gpm (114 lpm)	25 microns 30 gpm (114 lpm)	25 microns 30 gpm (114 lpm)	25 microns 30 gpm (114 lpm)
Hydraulic fluid Petroleum based (premium grade, anti-wear, non-conductive) Viscosity (at min. and max. operating temps)	100-400 ssu*	100-400 ssu* (20-82 centistokes)	100-400 ssu*	100-400 ssu*
<b>NOTE:</b> When choosing hydraulic fluid, the expected oil temperature extremes that will be experienced in service determine the most suitable temperature viscosity characteristics. Hydraulic fluids with a viscosity index over 140 will meet the requirements over a wide range of operating temperatures.				
*SSU = Saybolt Seconds Universal				

### EHTMA HYDRAULIC SYSTEM REQUIREMENTS

#### CLASSIFICATION

					
Flow Range	3.5-4.3 gpm (13.5-16.5 lpm)	4.7-5.8 gpm (18-22 lpm)	7.1-8.7 gpm (27-33 lpm)	9.5-11.6 gpm (36-44 lpm)	11.8-14.5 gpm (45-55 lpm)
Nominal Operating Pressure (at the power supply outlet)	1870 psi (129 bar)	1500 psi (103 bar)	1500 psi (103 bar)	1500 psi (103 bar)	1500 psi (103 bar)
System relief valve setting (at the power supply outlet)	2495 psi (172 bar)	2000 psi (138 bar)	2000 psi (138 bar)	2000 psi (138 bar)	2000 psi (138 bar)

**NOTE:** These are general hydraulic system requirements. See tool specification page for tool specific requirements

# OPERATION

The recommended hose size is .500 inch/12 mm I.D. up to 50 ft/15 m long and .625 inch/16 mm I.D. minimum up to 100 ft/30 m.

## PRE-OPERATION PROCEDURES

### CHECK POWER SOURCE

1. Using a calibrated flowmeter and pressure gauge, check that the hydraulic power source develops a flow of 7-9 gpm/26-34 lpm at 1500-2000 psi/105-140 bar.
2. Make certain the hydraulic power source is equipped with a relief valve set to open at 2100-2250 psi/145-155 bar maximum.

### INSTALL TOOL BIT

1. Rotate the latch on the breaker foot downward (pointing away from the tool).
2. Insert the tool bit into the foot and pull the latch up to lock the tool bit in place.

### CONNECT HOSES

1. Wipe all hose couplers with a clean, lint-free cloth before making connections.
2. Connect the hoses from the hydraulic power source to the tool fittings or quick disconnects. It is a good practice to connect return hoses first and disconnect them last to minimize or avoid trapped pressure within the tool.
3. Observe flow indicators stamped on hose couplers to ensure that fluid flow is in the proper direction. The female coupler on the tool hose is the inlet coupler.
4. Move the hydraulic circuit control valve to the ON position to operate the tool.

#### NOTE:

**If uncoupled hoses are left in the sun, pressure increase within the hoses may make them difficult to connect. When possible, connect the free ends of the hoses together.**

## OPERATION PROCEDURES

1. Observe all safety precautions.
2. Install the appropriate tool bit for the job.
3. Place the bit firmly on the surface to be broken.
4. Squeeze the trigger to start the breaker. Adequate down pressure is very important. When the tool bit breaks through the obstruction or becomes bound, release the trigger and reposition the tool bit.

#### NOTE:

**Partially depressing the trigger allows the tool to run at slow speed. Slow-speed operation permits easier starting of the tool bit into the work surface.**

5. To start, break an opening (hole) in the center of the surface. After making a hole, break portions of the material into the original opening. For best productivity, the breaking should be done around the original hole.

The size of the broken material will vary with the strength and thickness of the base material and the amount of any reinforcement wire or rebar.

Harder material or more reinforcing wire or rebar will require taking smaller bites. To determine the most effective bite, start with 2 in. / 50 mm or smaller bites.

Bites can then be gradually increased until the broken piece becomes too large, requiring increased time to break off the piece.

Sticking of the tool bit occurs when too large a bite is being taken and the tool bit hammers into the material without the material fracturing. This causes the tool bit to become trapped in the surrounding material.

6. The underwater model requires preventative maintenance after each day's use underwater and prior to being placed in storage. See the General Service Notes section in this manual for this maintenance procedure.

## COLD WEATHER OPERATION

If the breaker is to be used during cold weather, preheat the hydraulic fluid at low engine speed. When using the normally recommended fluid, fluid temperature should be at or above 50 °F/10 °C (400 ssu/82 centistokes) before use.

Damage to the hydraulic system or breaker can result from use with fluid that is too viscous or thick.

## TOOL PROTECTION & CARE

### NOTICE

In addition to the Safety Precautions found in this manual, observe the following for equipment protection and care.

- Make sure all couplers are wiped clean before connection.
- The hydraulic circuit control valve must be in the “OFF” position when coupling or uncoupling hydraulic tools. Failure to do so may result in damage to the quick couples and cause overheating of the hydraulic system.
- Always store the tool in a clean dry space, safe from damage or pilferage.
- Make sure the circuit PRESSURE hose (with male quick disconnect) is connected to the “IN” port. The circuit RETURN hose (with female quick disconnect) is connected to the opposite port. Do not reverse circuit flow. This can cause damage to internal seals.
- Always replace hoses, couplings and other parts with replacement parts recommended by Stanley Hydraulic Tools. Supply hoses must have a minimum working pressure rating of 2500 psi/172 bar.
- Do not exceed the rated flow and pressure. See Specifications in this manual for correct flow rate and pressure rating. Rapid failure of the internal seals may result.
- Always keep critical tool markings, such as warning stickers and tags legible.
- Do not force a small breaker to do the job of a large breaker.
- Keep tool bit sharp for maximum breaker performance. Make sure that tool bits are not chipped or rounded on the striking end.
- Never operate a breaker without a tool bit or without holding it against the work surface. This puts excessive strain on the breaker foot.
- Tool repair should be performed by experienced personnel only.
- Make certain that the recommended relief valves are installed in the pressure side of the system.
- Do not use the tool for applications for which it was not intended.

# TROUBLESHOOTING

PROBLEM	CAUSE	REMEDY
Tool does not run.	Power unit not functioning.	Check power unit for proper flow and pressure (7–9 gpm/26–34 lpm, 1500–2000 psi/105–140 bar).
	Couplers or hoses blocked.	Remove restriction.
	Pressure and return line hoses reversed at ports.	Be sure hoses are connected to their proper ports.
	Mechanical failure of piston or automatic valve.	Disassemble breaker and inspect for damaged parts.
Tool does not hit effectively.	Power unit not functioning.	Check power unit for proper flow and pressure (7–9 gpm/26–34 lpm, 1500–2000 psi/105–140 bar).
	Couplers or hoses blocked.	Remove restriction.
	Low accumulator charge (pressure hose will pulse more than normal).	Recharge accumulator. Replace diaphragm if charge loss continues.
	Fluid too hot (above 140 °F/60 °C).	Provide cooler to maintain proper fluid temperature (130 °F/55 °C).
	The collar support is not sliding freely in the foot bore.	Remove, clean and replace as required. Make sure hex bushing is in the proper location.
Tool operates slow.	Low gpm supply from power unit.	Check power unit for proper flow (7–9 gpm/26–34 lpm).
	High backpressure.	Check hydraulic system for excessive backpressure (over 250 psi/17 bar).
	Couplers or hoses blocked.	Remove restriction.
	Orifice plug blocked.	Remove restriction.
	Fluid too hot (above 140 °F/60 °C) or too cold (below 60 °F/16 °C).	Check power unit for proper fluid temperature. Bypass cooler to warm the fluid or provide cooler to maintain proper temperature.
	The collar support is not sliding freely in the foot bore.	Remove, clean and replace as required. Make sure hex bushing is in the proper location.
	Relief valve set too low.	Adjust relief valve to 2100–2250 psi/145–155 bar.
Tool gets hot.	Hot fluid going through tool.	Check power unit. Be sure flow rate is not too high causing part of the fluid to go through the relief valve. Provide cooler to maintain proper fluid temperature (140 °F/60 °C max). Check the relief valve setting. Eliminate flow control devices.
Fluid leakage on tool bit.	Lower piston seal failure.	Replace seal.
Fluid leakage through charge valve cap.	Upper piston seal failure or accumulator O-ring failure or accumulator charge loss or failure.	Replace seals, recharge or replace accumulator diaphragm.
Fluid leakage around trigger.	Valve spool seal failure.	Replace seals.

# CHARGING THE ACCUMULATOR

## ACCUMULATOR TESTING PROCEDURE

To check or charge the accumulator the following equipment is required:

31254 Charge Kit: which includes the following.

- Accumulator Tester (Part Number 02835)
- Charging Assembly (P/N 15304)  
(P/N 15304 includes a liquid filled gauge with snub valve, hose and fittings.)
- NITROGEN bottle with an 1000 psi/70 bar minimum charge. (Not included in 31254 Charge Kit.)

### CAUTION

This assembly contains nitrogen under pressure

1. Remove the valve cap assembly from the breaker.
2. Remove the protective cap and loosen the 5/8-inch hex locking nut on the tool charging valve 1-1/2 turns.
3. Holding the chuck end of Accumulator Tester (P/N 02835) turn the gauge fully counterclockwise to ensure that the stem inside the chuck is completely retracted.
4. Thread the tester onto the accumulator charging valve. Do not advance the gauge-end into the chuck-end. Turn as a unit. Seat the chuck on the accumulator charging valve and hand tighten only.
5. Advance the valve stem of the tester by turning the gauge-end clockwise until a pressure is read on the gauge (charge pressure should be 700-900 psi/48-62 bar).
6. If pressure is OK unscrew the gauge-end from the chuck to retract the stem, then unscrew the entire tester assembly from the accumulator charging valve. If pressure is low, charge the accumulator as described in the following paragraph.
7. Tighten the 5/8-inch hex locking nut on the tool charging valve. Be careful not to overtighten. Install the protective cap and valve cap assembly.

## ACCUMULATOR CHARGING

1. Perform steps 1 through 4 of the accumulator testing procedure above.
2. Connect the chuck of the charging assembly to the charging valve on the accumulator tester or, if preferred, remove the tester from the charging valve and connect the charging assembly chuck directly to the charging valve.
3. Adjust the regulator to the charging pressure of 800 psi/55 bar.

### NOTE:

**It may be necessary to set the gauge at 850-900 psi/59-62 bar to overcome any pressure drop through the charging system.**

4. Open the valve on the charging assembly hose.
5. When the accumulator is fully charged close the valve on the charging assembly hose and remove the charging assembly chuck from the accumulator tester or tool charging valve.  
  
If the accumulator tester has been used, be sure to turn the gauge-end fully counterclockwise before removing the tester from the charging valve of the tool.
6. Tighten the 5/8-inch hex locking nut on the tool charging valve and replace the protective cap.
7. Replace the valve cap assembly.

## GENERAL SERVICE NOTES

1. If the breaker is repainted after servicing, be sure to mask off the vent in the valve cap assembly. Do not allow paint to enter the IN and OUT ports or the bore of the foot assembly.
2. If the handle grips need to be replaced.
  - a. Remove the old grips and clean the handle.
  - b. Wash the new grips and the handle clean and dry, simply push or drive the grips on. DO NOT lubricate the parts. The grips will not be secure on the handle if any grease or oil is used.

# CHARGING THE ACCUMULATOR

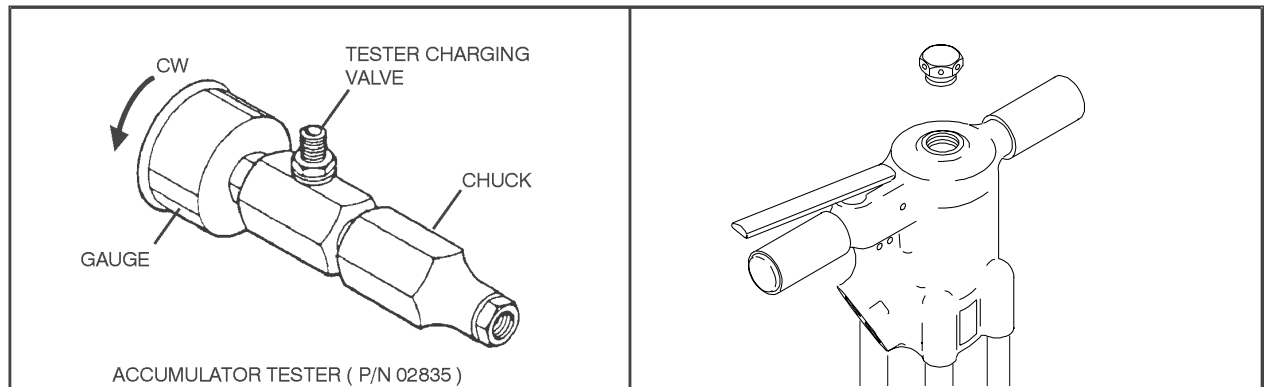
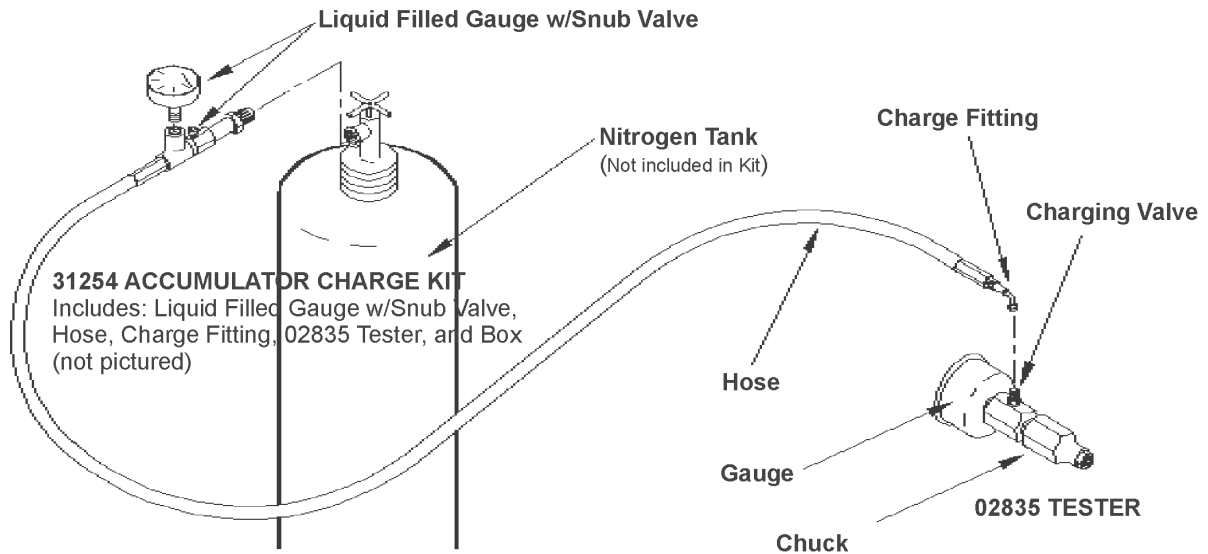

Figure 2. Charging the Accumulator

## UNDERWATER MODEL PREVENTATIVE MAINTENANCE

After each use, the movable portions of the tool that were exposed to water should be flushed with a water displacing oil such as WD40™. Remove any remaining water and debris as follows:

1. Turn the tool upside down (without the tool bit) and spray oil through the drive hex and side holes in the breaker foot assembly to displace any remaining water in the lower piston cavity.
2. Spray oil into the On/Off valve trigger slot area.
3. Dip or spray the entire tool.
4. Cycle the tool hydraulically several times before storing away.



# SPECIFICATIONS

Pressure Range.....	1500–2000 psi/105–140 bar
Flow Range .....	7–9 gpm / 26–34 lpm
Nominal Flow.....	8 gpm / 30 lpm
Maximum Back Pressure.....	250 Psi/17 bar
Connect Size & Type.....	3/8 in. Male Pipe Hose Ends
Weight .....	80 lbs / 36 kg
Length.....	27 in. / 68 cm
Width .....	16 in. / 40 cm
System Type.....	Open or Closed Center HTMA Type II
Port Size .....	SAE 8 O-ring
HTMA/EHTMA Category .....	Type 2
Nominal Pressure .....	1500 psi/103 bar
Max Pressure .....	2000 psi/138 bar
Max Relief Pressure .....	2150 psi/148 bar

## BR87 SOUND AND VIBRATION DECLARATION

### Test conducted on BR8713201, operated at 8 gpm input

Measured A-weighted sound power level, L <sub>wa</sub> (ref. 1pW) in decibels	105 dBA
Uncertainty, K <sub>wa</sub> , in decibels	1.6 dBA
Guaranteed sound power level	106 dBA
Measured A-weighted sound pressure level, L <sub>pa</sub> (ref. 20 µPa) at operator's position, in decibels	102 dBA
Uncertainty, K <sub>pa</sub> , in decibels	3 dBA

Values determined according to noise test code given in ISO 15744, using the basic standard ISO3744. Test conducted by independent notified body to comply with 2000/14/EC:2005 requirements.

NOTE- The sum of a measured noise emission value and its associated uncertainty represents an upper boundary of the range of values which is likely to occur in measurements.

### Declared vibration emission value in accordance with EN 12096

Measured vibration emission value: 3-Axis	22.1m/sec <sup>2</sup>
Uncertainty: K	2.9 m/sec <sup>2</sup>
Measured vibration emission value with uncertainty: 3-Axis	25.0 m/sec <sup>2</sup>
Measured vibration emission value: Z-Axis	18.4 m/sec <sup>2</sup>
Uncertainty: K	2.6 m/sec <sup>2</sup>
Measured vibration emission value with uncertainty: Z-Axis	21.0 m/sec <sup>2</sup>

Values determined according to ISO 8662-5, ISO 5349-1,2



# ACCESSORIES

## ACCESSORIES

### 1-1/8 IN. HEX × 6 IN. SHANK

Moil Point, 14 in. Long UC.....	02333
Chisel Point, 14 in. Long UC.....	03990
3-inch Chisel, 14 in. Long UC.....	02334
Clay Spade, 5-1/2 in. Blade.....	02331
Asphalt Cutter, 5 in. Blade, 11 in. Long.....	02332
Asphalt Wedge.....	08106
Ground Rod Driver, 1-in. Rod.....	04176

### 1-1/4 IN. HEX × 6 IN. SHANK

Asphalt Cutter, 5 in. Blade, 11 in. Long UC.....	02335
Moil Point, 14 in. Long UC.....	02336
3-inch Chisel, 14 in. Long UC.....	02337
1- inch Chisel, Heavy Duty, 14 in. Long UC.....	02338
Ground Rod Driver, 1 in. Rod.....	04367
Moil Point, Heavy Duty, 18 in. Long UC.....	04404
Clay Spade, 8 in./20 cm Blade.....	04405
Asphalt Wedge.....	08119
Clay Spade, 5-1/2 in. Blade.....	09262

### TEST EQUIPMENT

Accumulator Tester.....	02835
Flow and Pressure Tester.....	04182
Accumulator Charge Kit (Includes 02835 Tester, 15304 Accumulator Charge Assy and 372047 Box).....	31254
Accumulator Charge Assy (Includes Liquid Filled Gauge with Valve, Hose and Charge Fitting).....	15304

UC denotes dimension measured from bottom tip of tool to bottom surface of collar.

## SERVICE TOOLS

O-ring Tool Kit.....	04337
Seal Kit.....	05485
Accumulator Disassembly Tool.....	05508
Accumulator cylinder Puller.....	05640
Split Rings.....	04908
Flow Sleeve Installation Spacer.....	04909
Flow Sleeve Removal Tube.....	04910

# BR87 PARTS ILLUSTRATION

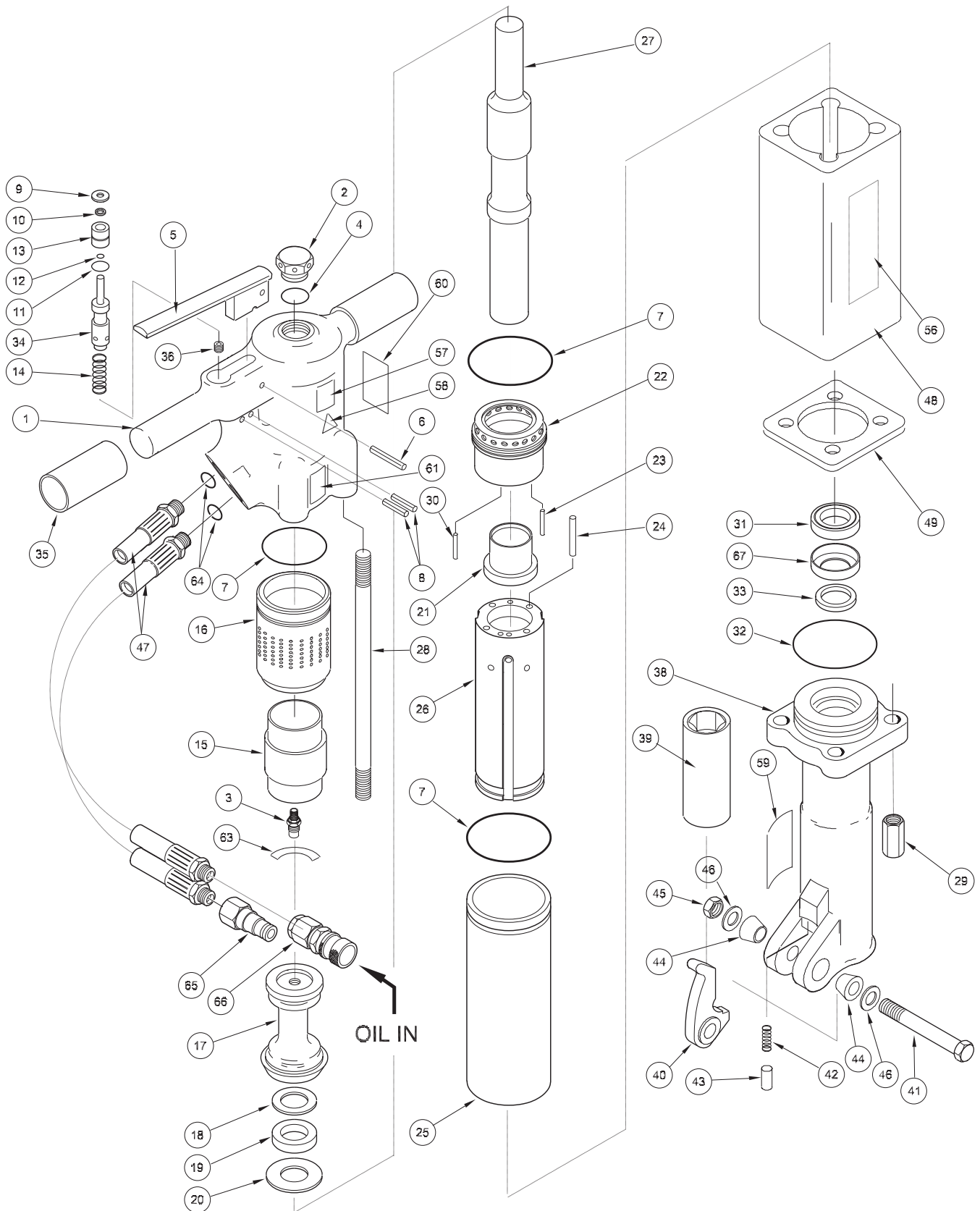

# BR87 PARTS ILLUSTRATION

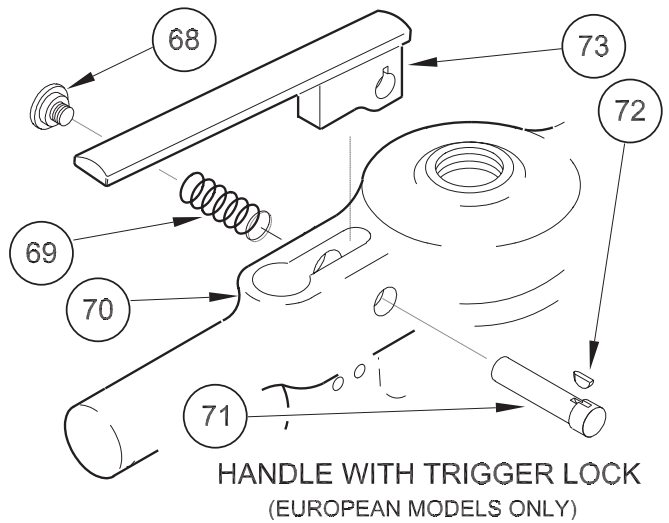
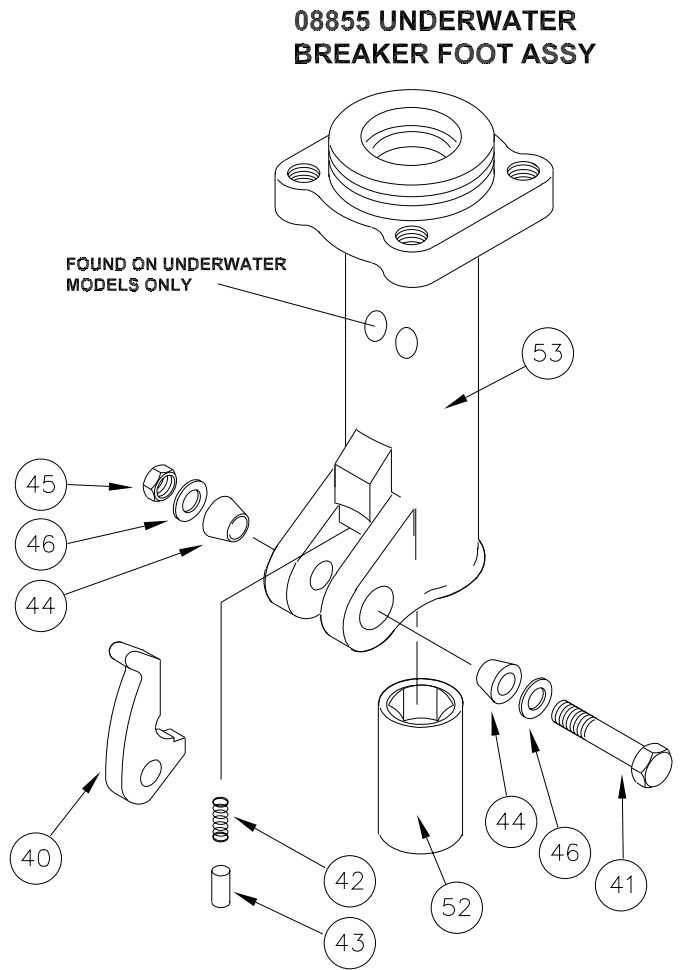
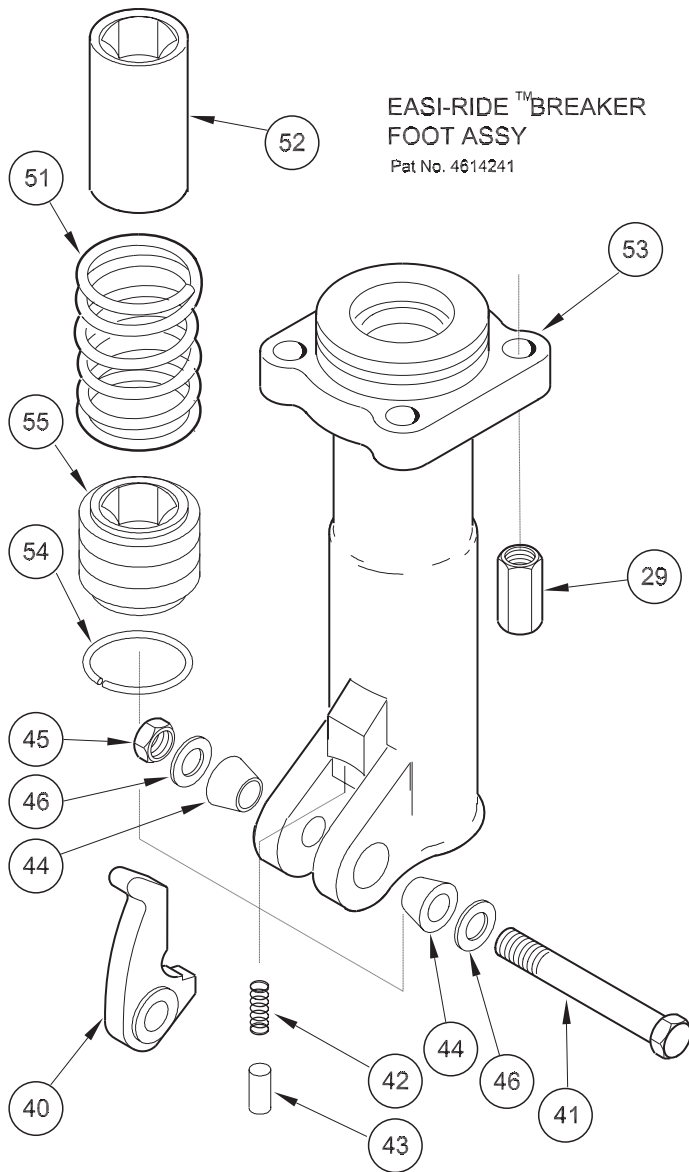

# BR87 PARTS LIST

Item No.	Part No.	Qty	Description
1	06185	1	HANDLE ASSY (INCL ITEM 35)
	11435	1	BREAKER HANDLE (TRIGGER LOCK MODELS ONLY)
2	04050	1	VALVE CAP ASSY
3	04051	1	CHARGING VALVE
4	04052	1	O-RING
5	04053 11434	1	TRIGGER TRIGGER (TRIGGER LOCK MODELS ONLY)
6	00844	1	SPIROL PIN
7	04054	3	O-RING
8	22891	2	SPIROL PIN, 3/16 × 1-5/8
9	04055	1	WASHER
10	04056	1	ROD WIPER
11	00293	1	O-RING
12	01362	1	O-RING
13	04057	1	BUSHING
14	04058	1	SPRING
15	04059	1	ACCUMULATOR DIAPHRAGM
16	04060	1	ACCUMULATOR CYLINDER
17	05309	1	ACCUMULATOR CHAMBER ASSY
	06889	1	ACCUMULATOR ASSEMBLY (INCL ITEMS 3, 7, 15-19)
18	05301	1	BACK-UP WASHER
19	05307	1	CUP SEAL
20	04064	1	WASHER
21	04065	1	AUTOMATIC VALVE
22	04066	1	AUTOMATIC VALVE BODY
23	04571	2	PUSH PIN, 3/16 × 1-1/4
24	04067	4	PUSH PIN, 5/16 × 2
25	04068	1	FLOW SLEEVE TUBE
26	04069	1	FLOW SLEEVE
27	16812	1	PISTON
28	04071	4	SIDE ROD
29	04075	4	SIDE ROD NUT
30	07890	1	ROLL PIN, 3/16 × 1-1/2
31	34127	1	CUP SEAL
32	04073	1	O-RING
33	04074	1	ROD WIPER
34	04077	1	VALVE SPOOL, OC
35	02494	2	HANDLE GRIP
36	05465	1	ORIFICE PLUG
37	05466	1	FOOT ASSY 1-1/8 HEX (INCL ITEMS 31-33 & 38-46 & 67)
	05467	1	FOOT ASSY 1-1/4 HEX (INCL ITEMS 31-33 & 38-46 & 67)
38	05484	1	FOOT ASSY (INCL ITEMS 33-67)
	07523	1	EASI-RIDE™ FOOT ASSY 1-1/8 HEX (INCL ITEMS 33, 40-46 & 51-55)
	07486	1	EASI-RIDE™ FOOT ASSY 1-1/4 HEX (INCL ITEMS 33, 40-46 & 51-55)
39	04081 04597	1	HEX BUSHING, 1-1/8 HEX HEX BUSHING, 1-1/4 HEX
40	01837	1	LATCH
41	04983	1	BOLT
42	01744	1	SPRING
43	01745 08411	1	DETENT, 1.000 OAL (SERIAL NO. 1707 AND BELOW) DETENT, 1.250 OAL (SERIAL NO. 1708 AND ABOVE)

Item No.	Part No.	Qty	Description
44	01269	2	RUBBER SLEEVE, 1.000
45	04984	1	STOP NUT
46	04985	2	SPRING WASHER
47	09546	2	PIGTAIL HOSE ASSY
48	05265	1	FLOW SLEEVE HOUSING
49	24666	1	ELASTOMETRIC SPACER
51	07515	1	SPRING
52	07517 07518	1	HEX BUSHING, 1-1/8 HEX BUSHING, 1-1/4
	04081	1	HEX BUSHING, 1-1/8 U/W ONLY
53	11614	1	BREAKER FOOT ASSY
	08855	1	BREAKER FOOT ASSY U/W ONLY (INCL ITEMS 31-33, 40-46, 52, & 67)
54	07522	1	RETAINING RING
55	08115 08116	1	COLLAR SUPPORT ASSY 1-1/8 W/WEAR RINGS COLLAR SUPPORT ASSY 1-1/4 W/WEAR RINGS
56	07892 28381	1	NAMEPLATE DECAL NAMEPLATE DECAL (BR8713201 & BR8717201 ONLY)
57	28322	1	CE DECAL
58	11207	1	CIRCUIT TYPE "D" DECAL
59	11208	1	HEX SHANK LENGTH DECAL
60	72786	1	GUARANTEED SOUND POWER LEVEL DECAL
61	28409	1	COMPOSITE DECAL
62	—	—	NO ITEM
63	10180	1	CAUTION DECAL
64	01605	2	O-RING (INCL WITH ITEM 47)
65	03973	1	FLUSH FACE COUPLER, MALE
66	03972	1	FLUSH FACE COUPLER, FEMALE
	03971	1	COUPLER SET
67	05464	1	SEAL INSERT
68	01003	1	BUTTON
69	11430	1	SPRING
70	11435	1	HANDLE
71	11431	1	LOCK PIN
72	11432	1	KEY
73	11434	1	TRIGGER

SEAL KIT PART NUMBER 05485		
Part No.	Qty	Description
00293	1	O-RING
00678	1	O-RING
01362	1	O-RING
01605	2	O-RING
04052	1	O-RING
04054	3	O-RING
04056	1	ROD WIPER
04073	1	O-RING
04074	1	ROD WIPER
05307	1	CUP SEAL
05641	1	O-RING
34127	1	CUP SEAL

# UNDERWATER TOOLS DEPTH GUIDELINE

## UNDERWATER MODELS ONLY

### **⚠ CAUTION**

**DO NOT USE HYDRAULIC TOOLS UNDERWATER THAT ARE NOT DESIGNATED AS AN “UNDERWATER” MODEL, OR THIS WILL RESULT IN DAMAGE TO THE TOOL.**

For underwater hydraulic tools the applications are broken down into four quadrants depending on type of tool and method of operation.

The types of tools are percussive and rotational, each with different characteristics allowing for different depth operation. With percussive tools, the nitrogen accumulator PSI must counter the increase in ambient pressure found at lower depths. Since there is a maximum PSI for percussive tools they are limited to certain depths. Rotational tools do not have accumulators and thus capable of deeper depths.

The methods are broken into diver operated or remote operated vehicle (ROV). ROV's can reach lower depths and with an on-board hydraulic power source that is depth compensated, can operate hydraulic tools at depths of thousands of feet. ROV operation is still limited to the tool, for example a percussive tool has the same depth limitation whether ROV or diver operated.



## Operation Overview

	Percussive	Rotational
Diver	Tools: Breakers, Hammer Drills and Chipping Hammers  Max Depth: 500' - limitations due to accumulator PSI max (increase 40 PSI for every 100')	Tools: Grinders, Saws, Chain Saws  Max Depth: 1000' - Reference hose sizing guide below
ROV	Tools: Breakers, Hammer Drills and Chipping Hammers  Max Depth: 500' - limitations due to accumulator PSI max (increase 40 PSI for every 100')	Tools: Grinders, Saws, Chain Saws  Max Depth: 1000' - Reference hose sizing guide below

## Recommended Hose Diameters

Depth (ft)	8 GPM	12 GPM
100	5/8"	5/8"
300	3/4"	1"
600	1"	1"
1000	1"	1-1/4"



# **STANLEY®**

Stanley Hydraulic Tools  
3810 SE Naef Road  
Milwaukie, Oregon 97267-5698 USA  
(503) 659-5660 / Fax (503) 652-1780  
[www.stanleyhydraulics.com](http://www.stanleyhydraulics.com)