

The ProtoTRAK® Parasolid Converter Operating Manual

Document: P/N 28070 Version: 111412
--

Parasolid for Mills
Compatible with offline and
SMX ProtoTRAK Control models



Southwestern Industries, Inc.

2615 Homestead Place

Rancho Dominguez, CA 90220

T | 310.608.4422 | F | 310. 764.2668

Service Department: 800.367.3165

e-mail: sales@southwesternindustries.com | service@southwesternindustries.com

web: southwesternindustries.com

Copyright © 2012, Southwestern Industries, Inc. All rights are reserved. No part of this publication may be reproduced, stored in a retrieval system, or transmitted, in any form or by any means, mechanical, photocopying, recording or otherwise, without the prior written permission of Southwestern Industries, Inc.

While every effort has been made to include all the information required for the purposes of this guide, Southwestern Industries, Inc. assumes no responsibility for inaccuracies or omission and accepts no liability for damages resulting from the use of the information contained in this guide.

All brand names and products are trademarks or registered trademarks of their respective holders.

Southwestern Industries, Inc.
2615 Homestead Place
Rancho Dominguez, CA 90220
Phn 310/608-4422 ☐ Fax 310/764-2668
Service Department
Phn 800/367-3165 ☐ Fax 310/886-8029

Table of Contents

ProtoTRAK Parasolid Converter Operating Manual

1.0	Introduction	2
1.1	Parasolid Versions	2
1.2	Parasolid Extensions	2
1.3	Mouse Required	2
1.4	Virus Protection	2
1.5	Microsoft Updates	2
2.0	Installing and Activating Parasolid Software	3
2.1	Installing	3
2.2	Activating	3
3.0	Using the Parasolid Converter for Mills	5
3.1	Opening a PARASOLID Program	5
3.2	Status Lines	5
3.3	Set Z Defaults	7
3.4	Orientating the Part	7
3.5	Set Program Absolute Zero	8
3.6	Editing the Drawing	9
3.7	Converting Geometry into a ProtoTRAK Part Program	9
3.8	Sample Exercise for Milling PARASOLID	13

1.0 Introduction

Thank you for your purchase of the ProtoTRAK Parasolid Converter software. In order to avoid repetition, this manual assumes you have basic proficiency with programming a ProtoTRAK CNC.

With the ProtoTRAK Parasolid converter, you may quickly and easily create ProtoTRAK part programs using the data stored in a Parasolid file.

With the ProtoTRAK Parasolid Converter, you are in complete control of the creation of your 2D or 2 ½ D part program. You pick the order of events and the direction you want to machine in an easy, interactive process. The coordinates are loaded into to the part program in the way you direct, leaving you the minimal task of adding the non-dimensional information in the prompted ProtoTRAK format.

1.1 Parasolid Versions

The ProtoTRAK Parasolid converter is only available for use with the ProtoTRAK SMX control used on mills. Its part number is CONV-PARA-M.

1.2 Parasolid Extension

Parasolid is a solid model file format owned by Siemens. Most solid graphical CAD systems can output as a Parasolid file. The standard program or file extension and the one that must be used with the ProtoTRAK is .X_T.

1.3 Mouse Required

You may run the Parasolid Converter on either the ProtoTRAK CNC or the ProtoTRAK Offline system (depending on which system you bought it for). If you run the converter on the ProtoTRAK CNC, you must have a mouse (or other pointing device) plugged into the mouse port or USB port, depending on the model of control. For ProtoTRAK controls that have USB drives available, a USB mouse should be recognized immediately after plugging in. But for the models that have the PS2 mouse port, if you didn't have the mouse plugged in at the time the ProtoTRAK was turned on, you must turn off the ProtoTRAK, plug in the mouse and then turn the system back on.

When running the Parasolid Converter on the ProtoTRAK CNC, a keyboard may be used but it is not necessary. You can use the front panel keys on the control pendant to input any data necessary throughout all the operations of the Parasolid Converter.

1.4 Virus Protection

As a device, ProtoTRAK CNCs are not generally susceptible to viral infections. The part "programs" they run are non-executable text files. You can further assure protection by avoiding e-mail programs and web browser programs loaded onto the ProtoTRAK and by using a router with a firewall. An anti-virus program is not necessary since the virus risk is low, and is not recommended because the background tasks may cause damage by interfering with ProtoTRAK real-time operation.

1.5 Microsoft Updates

Please note that the ProtoTRAK control is not designed to be automatically downloading updates from Microsoft, or for that matter any 3rd party software. There is only a limited amount of free space on the compact flash card, and downloading files to it until it is full may result in the ProtoTRAK to stop working properly.

Also note, that administrators must exclude the ProtoTRAK from programs such as Windows Server Update Service, where the software will automatically try to download updates to the control.

2.0 Installing and Activating Parasolid

The Parasolid Converter is optional software that must be purchased from Southwestern Industries. If you purchased this option with your machine or control, the software should already be installed and activated. If this is the case, you may skip the rest of this section.

You can tell if your converter is activated by looking at the data in Service Code 318 (Service Codes are found in the Set Up Mode). Service code 318 will display a list of all available converters. Active converters are displayed in black letters; inactive converters are displayed in gray letters. If the Parasolid Converter is not on the list at all, call the Southwestern Industries' Service Department.

If you purchased your Parasolid Converter separately from your machine or Offline System, you may have to install software first and then activate the option.

2.1 Installing the Parasolid Software

For ProtoTRAK SMX Pendants:

Please note that prior to downloading the Parasolid software, you may also need to download the latest master version of software. Go to service code 33 to see what version of master software is loaded on your control. You must have a 5.0 or later version loaded before you can download the Parasolid software. Please go to our website to find this latest software as instructed below.

To download the Parasolid software via a USB flash drive, or to obtain the latest version of any Parasolid software version, visit our website at www.southwesternindustries.com, go to the Software Downloads section and follow the instructions in order to download the latest software to your ProtoTRAK control.

To install, place the correct software on a USB device and plug into a USB port on the pendant. Press the SYS key, and then press the Update Options softkey to begin the process of loading the new software.

For ProtoTRAK Offline: The Parasolid software option will need to be downloaded separately from the offline software. You can download the latest version of offline software at www.southwesternindustries.com.

2.2 Activating Parasolid

After the software is loaded, you must activate the key (our way of controlling the use of the software) with the following procedure:

1. On your ProtoTRAK control, go to Service Code 318 Activate Converter (Service Codes are found in the Set Up Mode). Here you should see all active and inactive converters. Inactive converters will be listed in Gray. If the Parasolid Converter is not grayed out (i.e., it is black) it is already activated. Skip the rest of this section and go to 3.0 Loading a Parasolid part program.

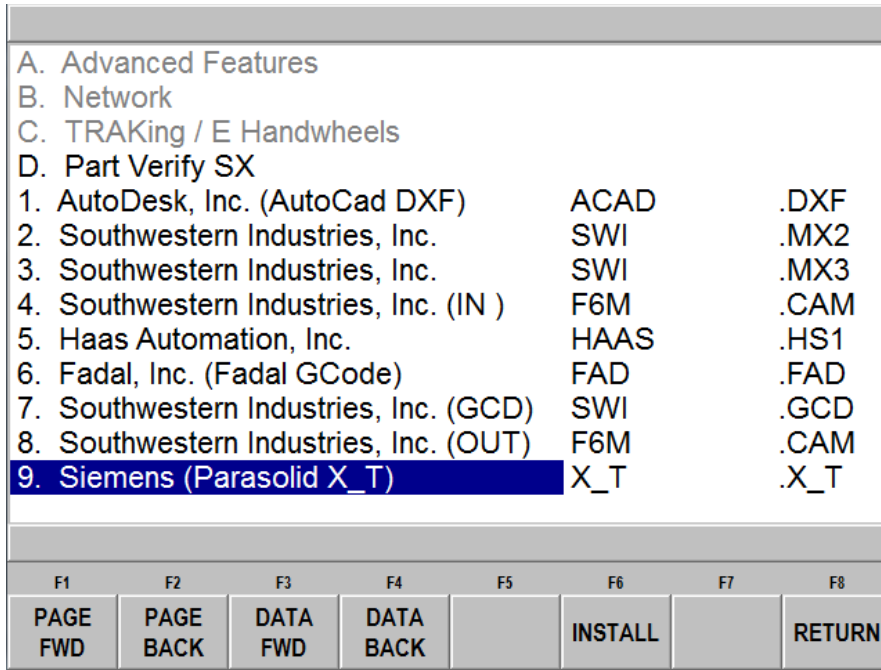

- Data Forward to the grayed out PARASOLID Converter option and press Install.
- A different screen will appear on which you will see a Hardware Key serial number, an Option Serial number and a phone number to contact SWI Customer Support. You will also see a blank field labeled "Activation Password". If you already have your activation password, enter that in now and press Inc Set or Abs Set.

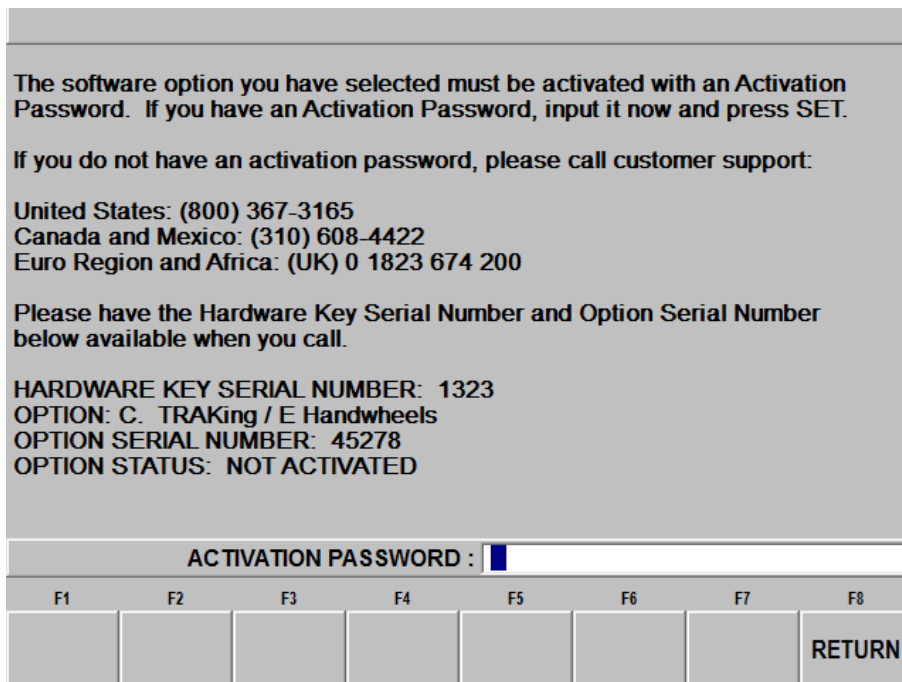

- If you do not already have the activation password, write down the Hardware Key serial number and Option serial number shown on the screen and call SWI Customer Support. After taking the serial numbers, SWI Customer Support will give you your password. Please

note, this option is not free. If you have not placed an order for the DXF Converter, you will need to do so before we can give you the activation password.

5. After the password is entered, the Parasolid Converter is ready for use.

3.0 Creating a ProtoTRAK Program Using the Parasolid Converter

Creating a ProtoTRAK .PT4 program from a .X_T Parasolid is very straight forward. If you are already familiar with the ProtoTRAK DXF converter you will find Parasolid very easy.

3.1 Opening a Parasolid Part Program

The Parasolid Converter is launched automatically when you open a Parasolid file with a .X_T extension.

The following screen will be displayed when you open a file.

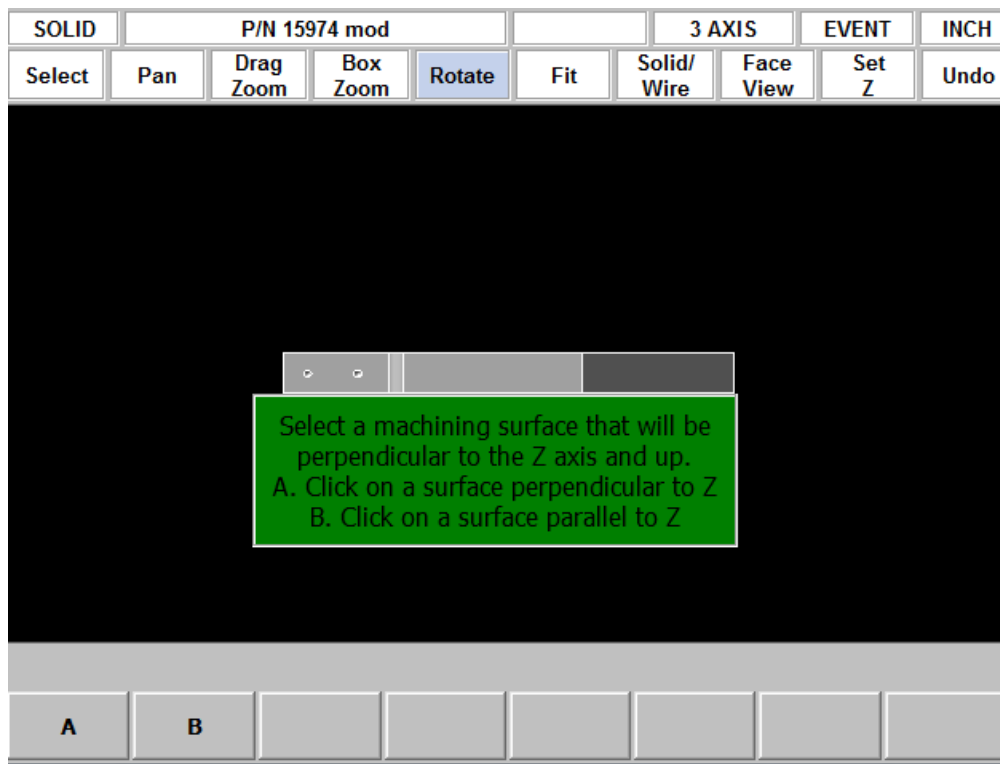

3.2 Status Line

The first line:

SOLID: indicates you are programming with the Parasolid Converter

P/N: shows the opened part number

AXIS: indicates 2 axis or 3 axis programming

EVENT: click to display a drop down box for programming non dimensional information in the events

INCH: indicates if dimensions are in inches or mm.

The second line:

Select: click to enable line, point or surface selecting. Turns off Pan, Zoom and Rotate. You may often be able to select even if this key is not active.

Pan: click to enable panning left, right, up or down. Left click and hold mouse to pan.

Drag Zoom: click to enable drag zoom in and out. Left click and hold mouse to zoom.

Box Zoom: click to enable box zoom. Left click and hold mouse at one location then move pointer diagonally and release to define area to be enlarged.

Rotate: click to enable rotation of part. Left click and hold then move mouse to rotate and release to stop rotation.

Fit: click to resize the part within the display area.

Solid/Wire: Press once to show solid only, again to show wire-frame only and again to show both (the default and generally best display)

Face View: Press to show face view. This will show the view as defined in the Parasolid until you have defined the top view in 3.4.

Set Z: defines the Z defaults – see section 3.3

Undo: undoes one mouse click

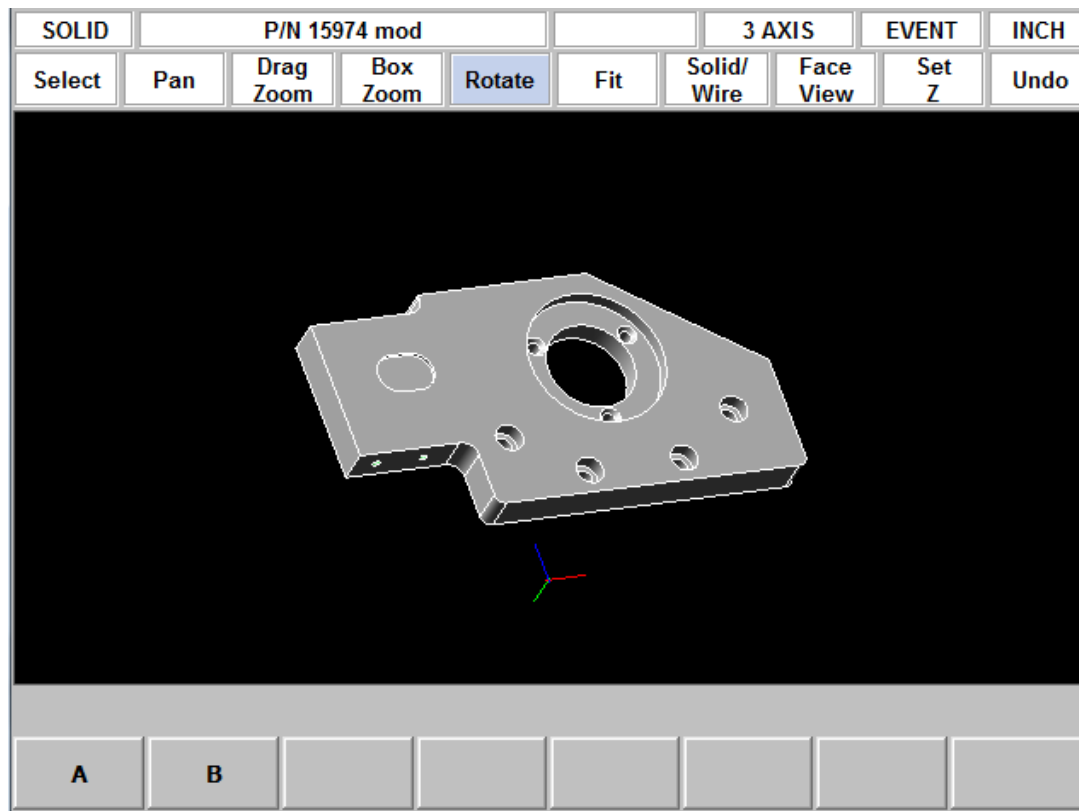

3.3 Set Z Defaults

Click on Set Z to call the following drop down box.

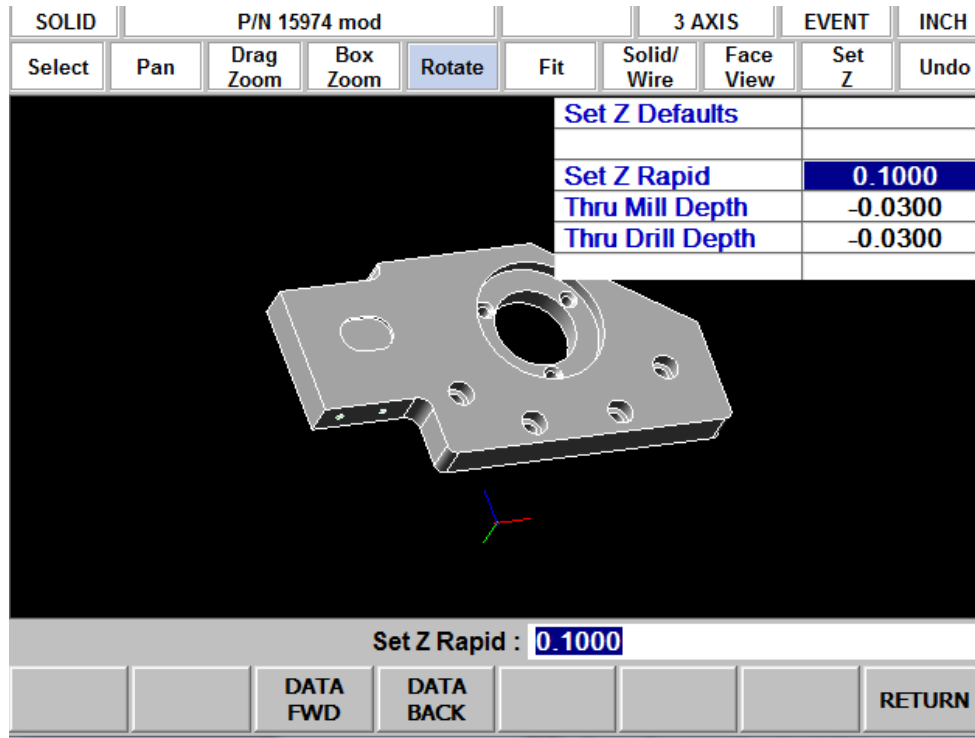

The data within the Parasolid knows the depth of every hole and surface. However, this is often not the depth you want your tool to go to. As you program the part you can choose whether you want the depth of the tool to be the same as the surface you choose or adjusted by the defaults you input in the Set Z drop down box.

Z Rapid: is the rapid to feed transition distance above the surface to be machined
Thru Mill Depth: is the distance (generally deeper and therefore minus) from the final depth surface. This is typical when machining a little below the bottom of a part when cutting around the part perimeter or through the part profile.
Thru Drill Depth: is the distance (generally deeper and therefore minus) from the final depth surface plus the Z dimension of the drill conical point. This is automatically calculated because the Parasolid knows the hole diameter and assumes a 118° point drill.

Click Set Z a second time to remove the drop down box.

3.4 Orientating the Part

From the screen in section 3.1 the Parasolid Converter is asking you to select which side is up on the part you are programming. Nearly always just select A, rotate the part to identify the up surface, click on that surface and click OK. Occasionally the up surface will be sloped (and therefore not perpendicular to Z) so click on B, rotate the part to find a vertical surface (a side or side of a hole), click on it and click OK.

Next, click TRANS AXIS (Translate Axis) one or more times to orientate the part to define positive X and Y. Click OK when satisfied. This is now your face view.

3.5 Setting Program Absolute Zero

3.5.1 Z Absolute Zero

When the part is properly oriented, the Parasolid Converter will ask you to set the part absolute zero. Rotate the part if necessary to show the Z absolute 0 (for example turn it over if the bottom of the part is your zero), click on the surface and click OK.

Notice the system is now in its two dimensional DXF format. This allows for much simpler selecting and programming.

The screen now shows:

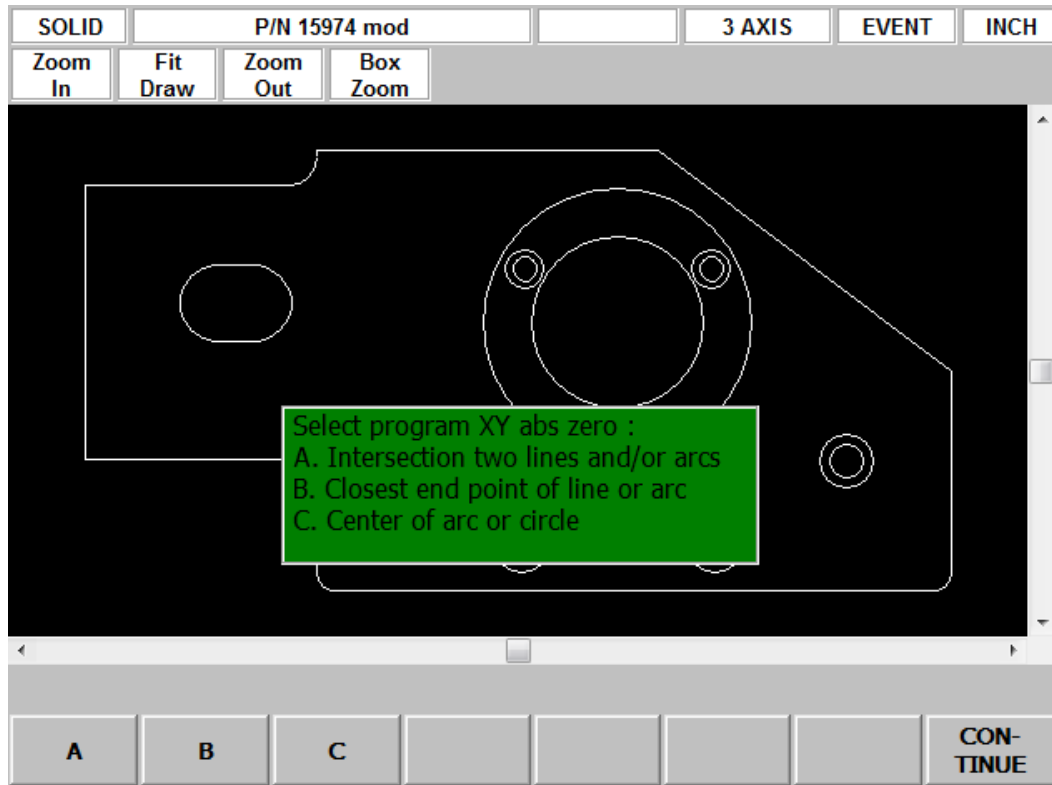

3.5.2 Choice A: An Intersection

This allows you to use intersecting points, like corners, as the absolute zero reference. The intersecting points can be taken from two lines, two arcs, or a combination of a line and an arc. Circles cannot be used with this choice.

To make an intersection the absolute reference, select choice A, then click on the two pieces of geometry that will intersect at the point you want to use. After you click on the second piece of geometry, a red mark will appear to show you where the absolute zero is now set.

This choice also allows the use of the intersection of two lines that meet off of the given geometry. If this is the case, you will not be able to see the red mark where the new absolute zero reference is set.

3.5.3 Choice B: An End Point

This allows you to use an end point of a line or an arc. Click on a line or arc close to the end point to be used as the absolute zero reference. Circles cannot be used with this choice.

3.5.4 Choice C: An Arc Center

This allows you to use the center of an arc or circle as the absolute reference point by simply clicking on an arc or circle.

Also notice the second status line choices have been modified as is appropriate for the 2-D DXF format.

3.6 Editing the Drawing

Sometimes the lines of the drawing aren't exactly what you need to machine. For example, you may want to add a ramp on or off at the beginning or end of a profile. You can easily add lines to the print using the Add Line and New Point feature. Once these lines are added, they may be programmed in exactly the same way as the other features of your part.

Add Line: Creates a line between existing beginning or end points of a line or arc. Click on one line or arc at a place nearest to the point you want to use. A red X will confirm the point that is selected. Next, click on another line or arc. The DXF will add a new line between these points you designated. To remove the line immediately after it is drawn, click the Undo button.

New Point: Creates a line between an existing beginning or end point on the drawing, and a new point you establish by clicking the mouse. Click on one line or arc at a place nearest to the point you want to use. A red X will confirm the point that is selected. Next, click wherever you want the line to end. The DXF will add a new line between these points you designated. To remove the line immediately after it is drawn, click the Undo button.

Hide Line: Click hide line then click on an unwanted line to hide it. Click UNDO to bring it back.

Break Geom: Allows intersecting lines to be broken into separate line segments. Click on one segment of one of the lines and then on one segment on the other line. Click on UNDO to unsegmentize the lines.

Inquire Geom: Click key then click any line, arc or circle. When clicking a circle the diameter will be shown beside the X and Y pointer location position under the part. Click line again to un-highlight. This feature may be useful to determine if you need to break geometry apart to create your part.

Press or click CONTINUE when editing is complete.

Note – if you continue and go to the next screen and begin to program your part and you realize you need to make an edit, you can go back to this screen by pressing the BACK button and edit without losing your program.

3.7 Converting Geometry into a ProtoTRAK Part Program

Now that the ProtoTRAK Parasolid Converter has the geometry, absolute reference and proper edits for the part, programming is just a matter of selecting the events. With the ProtoTRAK Parasolid Converter, you have total control over how the part is made - just like regular ProtoTRAK programming.

3.7.1 The basic steps are:

1. Pick the event type.

- Pick the geometry on the drawing (go to the solid if you want a better representation of the part). The X and Y dimensions will be loaded into the event type you choose.
- Click to show the drop down event. Click on the Z RAPID, click View Solid in the second status line, click on the surface that Z Rapid is measured from and click WITH OFFSET to load the appropriate value for Z RAPID.
- Click on Z END (if not already highlighted), click View Solid, click on the surface that is the same as Z END and click WITH OFFSET (for through events) or NO OFFSET (for exact depths). See note below for countersinks.

SOLID	P/N 15974 mod				3 AXIS	EVENT	INCH
Zoom In	Fit Draw	Zoom Out	Box Zoom	View Solid			

EVENT 1		DRILL	Not OK
DRILL OR BORE			
X	-2.9920	abs	
Y	-1.8120	abs	
Z RAPID	0.1000	abs	
Z END			
<input type="checkbox"/>	# PECKS FOR DRILL		
	RPM		
	Z FEEDRATE		
	TOOL #		

Z END : █						
PAGE FWD	PAGE BACK	DATA FWD	DATA BACK	INSERT EVENT	DELETE EVENT	EVENT #

SOLID	P/N 15974 mod				3 AXIS	EVENT	INCH		
Select	Pan	Drag Zoom	Box Zoom	Rotate	Fit	Solid/Wire	Face View	Set Z	Exit Solid

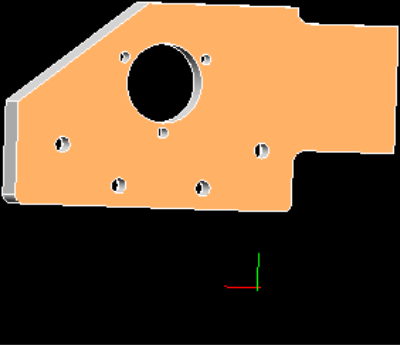

Z Depth: -1.0000						
WITH OFFSET	NO OFFSET					RETURN

- Fill in the rest of the prompts to complete the event.

6. Click EVENT to go back to the Select Event screen.
7. Repeat 1 through 5 for all geometry and events.
8. Click END SOLID when complete.

Countersink Note: For Z end on a countersink, zoom in and click the conical sloped surface. The parasolid knows the diameter and slope angle of the surface and will automatically calculate and load the proper Z dimension for the countersink point into the Z END prompt.

3.7.2 Event Types

Drill. Allows the conversion of any circle into a Drill event. All the same sized drills should be picked at the same time.

Mill. Allows the conversion of any straight line into a Mill event. Click on the end of the line where you want to establish the beginning point (X Beg, Y Beg).

Arc. Allows the conversion of any arc in the drawing into an Arc event. Click on the end on the arc where you want to establish the beginning point (X Beg, Y Beg).

Profile. Allows the conversion of any connecting lines and arcs into a Profile event. When selecting a profile event, the first line clicked determines where the profile starts and the second line clicked determines the direction of the profile. Each line or arc segment in the profile must be connected to each other but the profile may be open-ended.

Pocket. Allows the conversion of any connecting lines and arcs into a Pocket event. When selecting a pocket event, the first two lines clicked determine the direction of the Pocket (Clockwise or Counterclockwise). Pocket segment geometry must be connected to each other and must be closed – it needs to end where it began.

Tap. Allows the conversion of any circle into a Tap event. It should be noted that you cannot click on the Solid to fill in the Z END information. This prompt must be entered manually.

3.7.3 Event Groups

You create event groups out of items on the drawing that you want to machine the same way. Click on an event and then click all the similar pieces of geometry. When you press the Event key, the Parasolid Converter will automatically fill in the data in all the events in the event group by using the data you enter in the first event of an event group.

For example, say you have 5 holes to drill that are all the same size. To program these, select Drill and click on each of the five circles on the drawing that represent the drill locations. By doing this, you have created an event group made up of these five drill events. Now click on the Event button. The screen will change to show the prompts for the first event of this event group. When you fill in the blank prompts (the X and Y data is already there for you), the data you fill in will automatically be inserted into the other four events in the event group.

You can tell you are selecting items for the same event group by the color. When each item is selected, it turns purple.

If you want to separate event groups, simply select a different event between them. The other way to signal that you have finished selecting items for the event group is to click

on the Event button. When you do either of these things, the items will go from purple to blue, showing that you are no longer picking items for the event group.

Continuing with the example above, say that you want to counterbore the same five locations. The locations are the same, but you want to use a different tool, different RPMs and different Z dimensions. Therefore, you will establish a different event group. After you establish the first event group you can either click the Event button and program the data for the first group, click on the drill softkey again, or click on something other than Drill, and then select Drill again. You will now be working on a new event group.

3.7.4 Chaining

Chaining is a powerful feature of the Parasolid Converter that enables you to program pockets and profiles quickly and easily. You will be asked if you want to chain when you select Pocket or Profile. To use chaining select Yes, then click on the first line in the pocket or profile. The first line you select will determine where the ProtoTRAK begins to machine. You will then be prompted to continue. This second line tells the ProtoTRAK which direction to go.

Once the chaining begins, it will continue in the direction you choose until it encounters one of the following:

- An end point that is the same as the beginning of the profile or pocket event. This signals the completion of an enclosed shape.
- An intersection or branch that requires a decision from you. If this is encountered, the system will prompt you to select the direction by clicking the next line or arc segment you want included in the pocket or profile.

3.7.5 Color Schemes and Status Flags

Through out the conversion process on the 2D DXF presentation the geometry changes colors from white, to purple, to blue to green.

White – Geometry not yet associated with any ProtoTRAK event.

Purple - Geometry has been associated with a ProtoTRAK event; the event type is still current and the Undo feature active for that event.

Blue - Geometry has been associated with a ProtoTRAK event; the event type is no longer current (you changed event types) or the Event button has been pressed. Additional information needs to be entered before the event is complete. Undo feature does not work on the event.

Green - The event has been completely defined, no further input is needed.

When you click on the Event button to enter data necessary to complete an event, you will notice the "Not OK" flag at the top right hand corner. Once the event definition is complete, the flag changes to "OK". The part program will not run unless all events are OK.

3.7.6 Completing the Event

Once you choose the event type and then click on the features on the print, there are two ways to fill in the rest of the information like feed rates and tool numbers:

1. While still in the Converter, click on Event.
2. End the Parasolid Converter and go into Program mode.

Both ways provide you with the familiar, prompted interface of the ProtoTRAK, but we recommend that you choose the first way – stay in the Parasolid Converter and click the Event button.

We have two reasons for this recommendation. First, we have noticed that when we use the Parasolid Converter with large programs, we find that answering the prompts right away makes it a bit easier to keep things straight. Defining the event in its entirety before moving to the next event makes it unnecessary to remember event numbers later on.

The second reason is that using the Parasolid Converter allows you to establish event groups (event groups are described above). Event groups make it easy to program like pieces of geometry. For example, say you wanted to machine five holes the same size. Within the Parasolid Converter you would select Drill, then select each of the holes to add them to your event group. Then you would click on Event and fill in the prompts. The information that you put in the prompts for the first of the Drill events would be copied to the rest of the events in the event group. In contrast, if you end the Parasolid Converter and go to the Program Mode to fill in the prompts, you would have to fill in the same information for every drill event.

3.8 Sample Exercise

This exercise programs the part shown in this manual using the ProtoTRAK Parasolid Converter. Plug a mouse into your ProtoTRAK and follow the steps below.

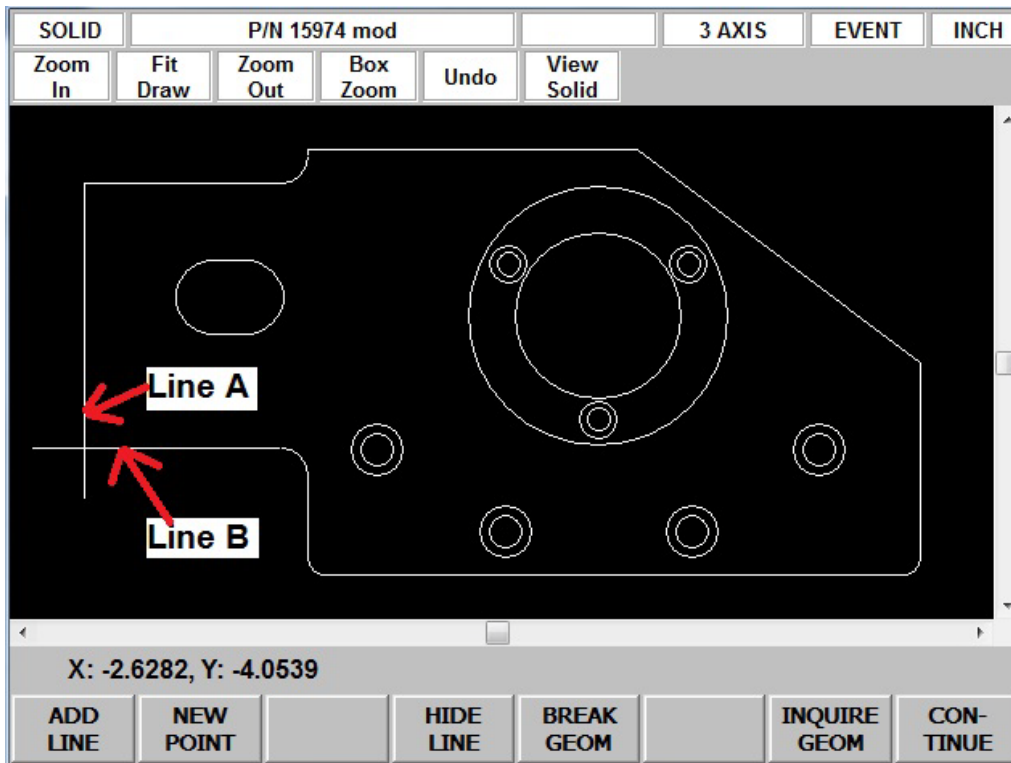

1. Open part number 15974 mod.X_T located in the X_T Sample program folder on the C drive of the ProtoTRAK.
2. Click A.
3. Rotate part to show side with 4 counterbored holes.

4. Click on top surface with the counterbored holes to declare it is up.
5. Click OK.
6. Click TRANS AXES 3 times to orientate part as shown in the figure above.
7. Click OK.
8. Click on the top surface to set Z absolute zero.
9. Click OK. Screen shifts to 2D DXF format.
10. Click C.
11. Click on either large circle line. Notice a red box at center of large circles. This is the X and Y absolute zero.
12. Click CONTINUE.
13. Click NEW POINT.
14. Click near bottom of line marked A, then drag a line down to form a ramp on move for machining the perimeter as shown in the figure above.
15. Click near the left side of line marked B, then drag a line to the left to form a ramp off move for machining the perimeter as shown in the figure above.
16. Click CONTINUE.
17. Click PROFILE to mill around the outer perimeter.
18. Click YES to chain.
19. Click the ramp on line created in step 14, then click the vertical line above it marked A above. The entire profile should now be purple.
20. Click EVENT to activate the drop down event box.
21. Press DATA FWD button to get to the Z RAPID prompt.
22. Click View Solid key in second status line.
23. Click the top surface as the reference from which Z RAPID is measured.
24. Click WITH OFFSET. The display goes back to the event screen and Z rapid is 0.1000 abs (our Set Z default).
25. Click View Solid again.
26. Rotate the part to show the bottom of the part.
27. Click the bottom surface.
28. Click WITH OFFSET because we want to machine a little lower than the bottom.
29. Load in rest of the event information as you would in ProtoTRAK programming. Use tool offset – LEFT and Tool 1.
30. Click EVENT to eliminate the drop down box.
31. Click POCKET.
32. Click YES to chain.
33. Click a line and an adjacent arc in the oval pocket.
34. Click EVENT drop down box.
35. Press DATA FWD button to get to the Z RAPID prompt.
36. Click View Solid, rotate to see the top of the part.
37. Click the top surface and click WITH OFFSET.
38. Click View Solid.
39. Click the bottom surface of the pocket (zoom if you need to) and click NO OFFSET because this is the exact depth that you want.
40. Load in the rest of the event information and use Tool 1.
41. Click EVENT to retract box.
42. Click POCKET, and NO to chain.
43. Click the larger circle around X/Y abs zero.
44. Click EVENT.
45. Data forward to the Z RAPID prompt and just input 0.1000 because you know where the top of the part is.
46. Click View Solid and zoom in a bit.
47. Click the surface that is at the bottom of the larger circle which is the same as top of the 3 countersink holes, then click NO OFFSET.

48. Load in the rest of the event information and use Tool 1. Notice the radius was input automatically because the Parasolid model knows this.
49. Click EVENT to retract the box.
50. Click PROFILE and NO to chain.
51. Click the smaller through hole around X/Y abs zero.
52. Click EVENT.
53. Press DATA FWD button to get to the Z RAPID prompt.
54. Click View Solid, click on the surface at the top of the 3 countersink holes and click WITH OFFSET.
55. Click View Solid, rotate the part to see the bottom, click on the bottom surface and click WITH OFFSET to go a little deeper.
56. Load in the rest of the event information and use Tool 1.
57. Click EVENT to retract the box.
58. Click DRILL.
59. Click the 3 inner circles in a bolt hole pattern around X/Y abs zero that represents the drilled holes.
60. Click EVENT and then input 1, SET for drill.
61. Press DATA FWD button to get to the Z RAPID prompt.
62. Click View Solid, click on the top surface of the holes/countersink and click WITH OFFSET.
63. Click View Solid again, rotate to see the bottom, click on the bottom and click WITH OFFSET to drill through the 0.030" offset plus the drill point length. Notice the total depth of the drill point is -1.1231 in a 1" plate.
64. Load in the rest of the event information and use Tool 2.
65. Click EVENT to retract the box.
66. Click DRILL.
67. Click the 3 outer circles in the bolt hole pattern around X/Y abs zero that represent the countersink holes.
68. Click EVENT and input 1, SET for drill.
69. Press DATA FWD button to get to the Z RAPID prompt and View Solid.
70. Click the top surface of the countersink and click WITH OFFSET.
71. Click View Solid again, click on the sloped conical surface of one of the countersinks , as shown below, and click NO OFFSET. Notice the Z END dimension is where the tip of the countersink must go.

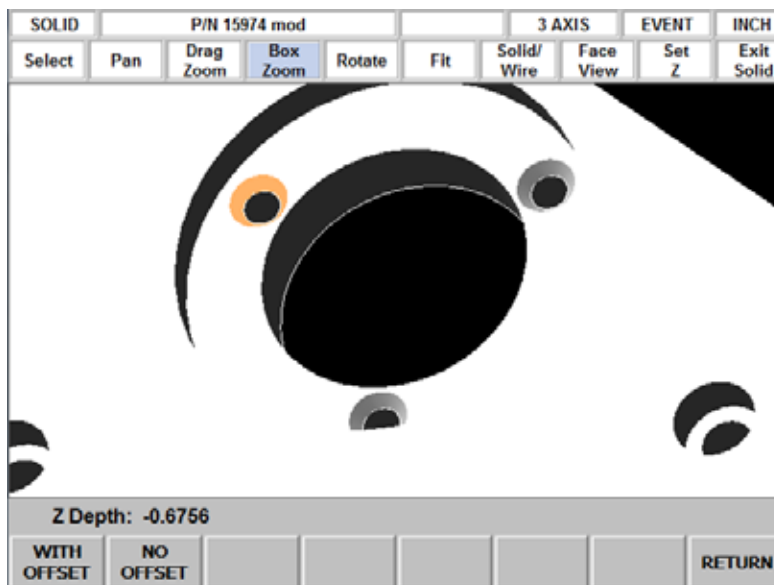

72. Load in the rest of the event information and use Tool 3.

I'll bet you have a good feel for this by now. Finish up the part by drilling and then counterboring (perhaps with a circle profile) the four holes.

When finished, click END SOLID to create a normal ProtoTRAK.PT4 program that you can run or edit as any other.