



**WINLAND  
ELECTRONICS, INC.**

# WATERBUG®

**Electronic Water Detection Device**



**WB-200**

## CONTENTS

This package contains:

- 1 WB-200
- 1 Surface Probe - Unsupervised (W-S-U)
- 1 Installation/Operating Instructions Guide

## SPECIFICATIONS

Power Requirement	8-28 VDC @ 35mA 8-28 VAC @ 100mA
Sensitivity	Will not alarm due to high humidity or condensation.
Operating Temp	32° to 130° F (0° to 54° C); non-condensing environment (indoor use only)
Output	1 Form C Relay (N.O./N.C.) 1 Amp @ 30 VDC, resistive 1 Amp @ 24 VAC, resistive
Probe Options	Includes 1 Standard Unsupervised Surface Probe (W-S-U) Accepts up to 6 Unsupervised Surface Probes (W-S-U) wired in parallel or Accepts up to 6 Unsupervised Under Carpet Probes (W-UC-U) wired in parallel.
Max Cable Length	1-2 probes; max recommended distance of 200' (61 m) 3-6 probes; max recommended distance of 100' (30.5 m)
Probe Cable	Probes include 15" (4.6 m) cable. Extend using 22-18 AWG twisted pair.
Console Weight	2.4 oz (0.07 kg)
Console Dimensions	4.1 x 2.36 x 1.18" (10 x 6 x 3 cm) with flanges
Probe Dimensions	Surface: 2 x 3 x 0.88" (5.1 x 7.6 x 2.2 cm) Under Carpet: 2 x 3 x 0.18" (5.1 x 7.6 x 0.5 cm)
Mounting	Flanges
Case Material	ABS
Warranty	1 Year Limited

Tech Support 8:00am - 5:00pm Central Time

(800) 635-4269 • +1-507-625-7231 P

[www.winland.com](http://www.winland.com)



## INTRODUCTION

Thank you for your purchase of the Winland WaterBug® model WB-200. The WB-200 is completely electronic and is designed to detect water only (distilled and deionized water cannot be detected). The WB-200 is not a self contained warning device. For proper operation, it must be used in conjunction with an alarm system, sounder, etc. It is designed so that the control console mounts on a wall or other flat vertical surface and the remote probes are placed in the locations where water leakage is most probable. Up to six remote probes may be connected to one control console. A film of moisture forming a bridge between the two metallic contacts on any remote probe is all that is needed for the unit to signal an alarm condition. The output on the WB-200 is non-latching, but will remain in alarm state until the moisture bridge is broken. As sensitive as the WB-200 is, it will not alarm due to high humidity or condensation. The WB-200 is ideal for use in homes, offices, computer rooms, warehouses, etc.

## INSTALLATION

Locate the area where the WB-200 console is to be mounted. Using the WB-200 as a guide, mark the two locations on the mounting surface where the holes will be drilled in order to use the case's mounting flanges. If mounting on drywall, use the two provided drywall anchors. Once the holes have been drilled, place the WB-200 against the surface and drive the screws into the holes or anchors.

Multiple probes must be hooked up in parallel to the two "sensor" terminals. The remote surface probes may be mounted securely to the floor or a wall. Mounting the probe(s) to a vertical surface like a wall enables you to monitor an area for rising water levels. This is useful in basement sump pumps and other types of water storage and drainage systems.

## TERMINAL BLOCK CONNECTIONS

Relay contacts are accessible on the terminal block (See Figure 1). The WB-200 is in normal condition when power is applied and no moisture is being detected. It's in alarm condition when water is detected by any one of the remote probes.

**Note:** When connecting DC power to the WB-200 be sure to observe polarity and test to see if the WB-200 is operating properly. This may be done by forming a water bridge between two of the metallic contacts located on the probe (See Figure 2) with a moistened finger or cloth. If the WB-200 is not operating properly, check the polarity of the power supply connections.

**AC** – Power input wires are interchangeable

**DC** – Positive to V+ and negative to Ground

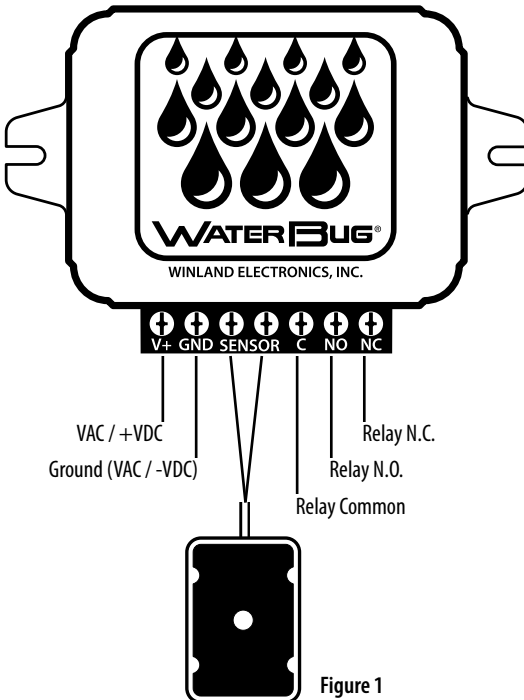

Figure 1

## TEST PROCEDURES

To test the WB-200 operational status, form a water bridge between the two metallic contact points (See Figure 2) with a moistened finger or cloth. If working properly, the WB-200 will activate the warning device to which it is connected within approximately three seconds. The WB-200 will reset automatically when the probe dries and there is no longer a water bridge between the two metallic contact points.

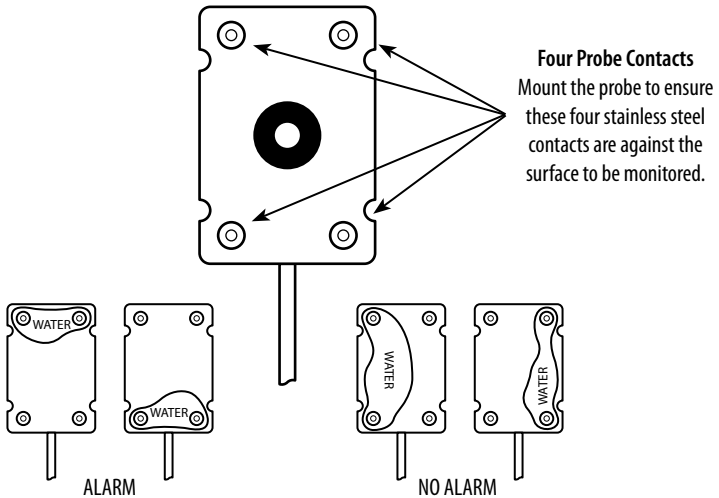

Figure 2

## STANDARD SURFACE PROBE UNSUPERVISED

If a remote probe is to be bolted down in a permanent installation, drill only in the innermost center recessed area (See Figure 3). Drilling anywhere other than the innermost circle may damage the internal wiring causing the WB-200 to fail.

Drill only in the innermost area.

## MONITORING FOR THE ABSENCE OF WATER

The WB-200 can be used to monitor for the absence of water (water level).

This is done by:

- 1 - mounting the probe at the desired minimum waterline and ;
- 2 - using the opposite set of relay contacts that you would use if you were detecting the presence of water.

To insure proper operation, test weekly.

Concrete can be semi-conductive. If experiencing false alarms, insulate all probes mounted on concrete.

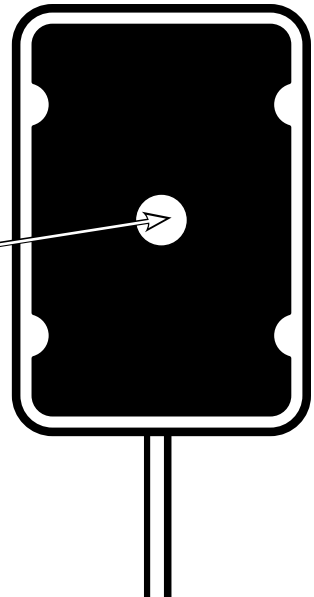
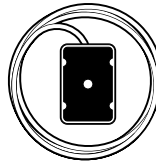

Figure 3

## ADDITIONAL PROBES

Multiple probes must be connected in parallel to the two "sensor" terminals. The WB-200 accepts up to 6 probes wired per console.



**W-S-U**

Water Probe - Surface  
Unsupervised

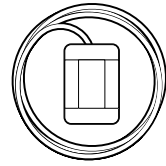

**W-UC-U**

Water Probe - Under Carpet  
Unsupervised

## WEEE Product Recovery/Recycling for EU Customers

In an effort to improve waste management in the European Union, the European Union has enacted directive 2002/96/EC on Waste Electrical and Electronic Equipment (WEEE Directive). According to the WEEE Directive, Winland Electronics must take back waste electrical or electronic equipment covered under the WEEE Directive, at its cost, for all product it puts on the market after July 1, 2006. The Return Process: Contact Winland via our web site at [www.winland.com](http://www.winland.com).



Radio Frequency Interference Requirements: This device complies with Part 15 of the FCC Rules. Operation is subject to the following two conditions: (1) This device may not cause harmful interference, and (2) this device must accept any interference received, including interference that may cause undesired operation.



CE Marking and European Union Compliance: Products intended for sale within the European Union are marked with the CE Mark, which indicates compliance to applicable Directives and European Norms (EN). Amendments to these Directives or ENs are included: Electromagnetic Compatibility Directive 2004/108/EC; Low Voltage Directive 2006/95/EC; RoHS Directive 2002/95/EC; WEEE Directive 2002/96/EC.

Statement of Compliance: Winland Electronics, Inc. hereby declares that this device is in compliance with all the applicable Directives 2004/108/EC, 2006/95/EC, 2002/95/EC, 2002/96/EC.

## Symbols on the Product or Manual Labeling



For product disposal, ensure the following:

- Do not dispose of this product as unsorted municipal waste.
- Collect this product separately.
- Use collection and return systems available to you.



WEEE Waste Electrical and Electronic Equipment  
RoHS Restriction of Hazardous Substances

## ONE YEAR LIMITED WARRANTY

Winland Electronics, Inc. ("Winland") warrants to the end user/purchaser that each product of its manufacture shall be free from defects in material and factory workmanship for a period of one year from the date of purchase, when properly installed and operated under normal conditions according to Winland's instruction. Winland's obligation under this warranty is limited to correcting, without charge, at its factory any part or parts thereof which shall be returned to the factory, by the original purchaser, transportation charges prepaid, within one year of the date of purchase and which upon examination, shall disclose to Winland's satisfaction to have been originally defective. Correction of such defects by repair to, or supplying replacements for, defective parts shall constitute fulfillment of all Winland's obligations to purchaser under this limited warranty. Repair service performed by Winland after one year from date of purchase will be for a reasonable service charge. This limited warranty shall not apply to any of Winland's products which have been subject to misuse, negligence or accident or which have been repaired or altered outside of Winland's factory. The warranty is void if the Product's housing or cover is removed. Winland shall not be liable for loss, damage or expense resulting, directly or indirectly, from the use of its products or any other cause. This warranty shall be null and void in its entirety if: (i) the product is altered or modified in any way that is not consistent with the manufacturer's instructions, or (ii) the product is used with or connected to a device: (a) that such product is not intended to be used with or connected to, (b) is not otherwise consistent with the manufacturer's instructions, or (c) is not otherwise approved by the manufacturer. THIS WARRANTY IS IN LIEU OF ALL OTHER WARRANTIES, EXPRESS OR IMPLIED, INCLUDING, WITHOUT LIMITATION, ANY WARRANTIES OF MERCHANTABILITY, FITNESS FOR PARTICULAR PURPOSES, NON-INFRINGEMENT AND TITLE, AND ANY WARRANTIES ARISING FROM COURSE OF DEALING, USAGE OF TRADE OR OTHERWISE. ALL OTHER REPRESENTATIONS MADE TO THE END USER/PURCHASER BY ANY OTHER PARTY ARE ALSO EXCLUDED. WINLAND SHALL NOT BE LIABLE TO ANY PERSON FOR INDIRECT, SPECIAL, INCIDENTAL OR CONSEQUENTIAL DAMAGES OF ANY DESCRIPTION, WHETHER ARISING OUT OF WARRANTY OR OTHER CONTRACT, NEGLIGENCE OR OTHER TORT, OR OTHERWISE. Under no circumstances shall Winland's liability under this limited warranty exceed the purchase price paid by the end user/purchaser for the product. No person, agent or dealer is authorized to give warranties on behalf of Winland nor to assume for Winland any other liability in connection with any of its products.