

Stellaris® RDK-BDC24 Brushed DC Motor Control Module

User's Manual



Copyright

Copyright © 2010–2011 Texas Instruments, Inc. All rights reserved. Stellaris and StellarisWare are registered trademarks of Texas Instruments. ARM and Thumb are registered trademarks, and Cortex is a trademark of ARM Limited. Other names and brands may be claimed as the property of others.

Texas Instruments
108 Wild Basin, Suite 350
Austin, TX 78746
<http://www.ti.com/stellaris>



Table of Contents

Chapter 1: Stellaris® Brushed DC Motor Control Reference Design Kit (RDK) Overview	9
Feature Summary	10
Specification Overview	10
Reference Design Kit Contents	11
Chapter 2: Using the Reference Design Kit	13
Important Information.....	13
Developing with the RDK.....	13
Power Supply Selection.....	13
Motor Selection.....	14
Chapter 3: Firmware Updates and Debugging.....	15
General Information	15
Firmware Update Using RS232/CAN	15
Firmware Update and Debugging Using JTAG/SWD	15
Chapter 4: Hardware Description.....	17
System Description	17
Key Hardware Components.....	17
Schematic Description	17
Microcontroller, CAN, and I/O Interfaces (Schematic page 1)	17
Output Stage and Power Supplies (Schematic page 2).....	19
Texas Instruments' Featured Parts.....	22
Appendix A: Schematics.....	23
Appendix B: Board Drawing	27
Appendix C: Bill of Materials (BOM)	29

List of Figures

Figure 1-1. MDL-BDC24 Brushed DC Motor Control Module	9
Figure 1-2. MDL-BDC24 Module Key Features (top view)	11
Figure 3-1. Locating the JTAG/SWD Connector.....	15
Figure 3-2. Firmware Debugging Using JTAG/SWD	16
Figure 4-1. MDL-BDC24 Circuit Board	17
Figure 4-2. MDL-BDC24 JTAG/SWD Connector.....	18
Figure 4-3. Network Connector Pin Assignments.....	19
Figure 4-4. Synchronous Rectification.....	21
Figure B-1. Component Placement Plot.....	27

List of Tables

Table 2-1. Mabuchi RS-555PH-3255 Motor Specifications	14
Table 4-1. Detailed List of Texas Instruments' Featured Parts	22
Table C-1. RDK-BDC24 Bill of Materials (BOM)	29

Stellaris® Brushed DC Motor Control Reference Design Kit (RDK) Overview

The RDK-BDC24 is a Stellaris reference design for speed control of 12 V and 24 V brushed DC motors at up to 40 A continuous current. Features include high-performance CAN and RS232 networking as well as a rich set of control options and sensor interfaces, such as analog and quadrature encoder interfaces.

High-frequency PWM enables the DC motor to run smoothly and quietly over a wide speed range. The MDL-BDC24 uses highly optimized software and a powerful 32-bit Stellaris LM3S2616 microcontroller to implement open-loop speed control as well as closed-loop control of speed, position, or motor current.

The Reference Design Kit (RDK-BDC24) contains an MDL-BDC24 motor control module as well as additional hardware and software for evaluating RS232 communication. After evaluating the RDK-BDC24, users may choose to either customize parts of the hardware and software design or use the MDL-BDC24 without modification.

See the MDL-BDC24 board data sheet (available for download from <http://www.ti.com/stellaris>) for complete technical specifications. In addition, the *MDL-BDC24 Getting Started Guide* (GSG-MDL-BDC24) provides a step-by-step guide to wiring and using the module.

Figure 1-1. MDL-BDC24 Brushed DC Motor Control Module



Feature Summary

The MDL-BDC24 control board provides the following features:

- Controls brushed 12 V and 24 V DC motors up to 40 A continuous
- Controller Area Network (CAN) interface at 1 Mbit/s
- Industry-standard servo (PWM) speed input interface
- RS232 to CAN bridge
- Limit switch, encoder, and analog inputs
- Fully enclosed module includes cooling fan
- Flexible configuration options with simple source file modification
- Easy to customize—full source code and design files available

Specification Overview

Key specifications of the MDL-BDC24 include:

- Quiet control of brushed DC motors
 - 15 kHz PWM frequency
- Three options for Speed control
 - Industry-standard R-C servo type (PWM) interface
 - Controller Area Network (CAN) interface
 - RS232 serial interface
- CAN communication
 - Multicast shared serial bus for connecting systems in electromagnetically noisy environments
 - 1M bits/s bit rate
 - CAN protocol version 2.0 A/B
 - Full configurability of module options
 - Real-time monitoring of current, voltage, speed, and other parameters
 - Firmware update
- RS232 serial communication
 - Bridges RS232 port to a CAN network
 - Directly interfaces to a PC serial port or National Instruments cRIO
- Status LED indicates Run, Direction, and Fault conditions
- Motor brake/coast selector
- Limit switch inputs for forward and reverse directions
- Quadrature encoder input (QE1)
 - Index input
 - 5 V supply output to encoder

- Analog input
 - Accepts 10 kΩ potentiometer or 0-3 V input
- Screw terminals for all power wiring
- Headers (0.1 inch pitch) for all control signals

For detailed specifications including electrical parameters, see the MDL-BDC24 data sheet.

Figure 1-2. MDL-BDC24 Module Key Features (top view)

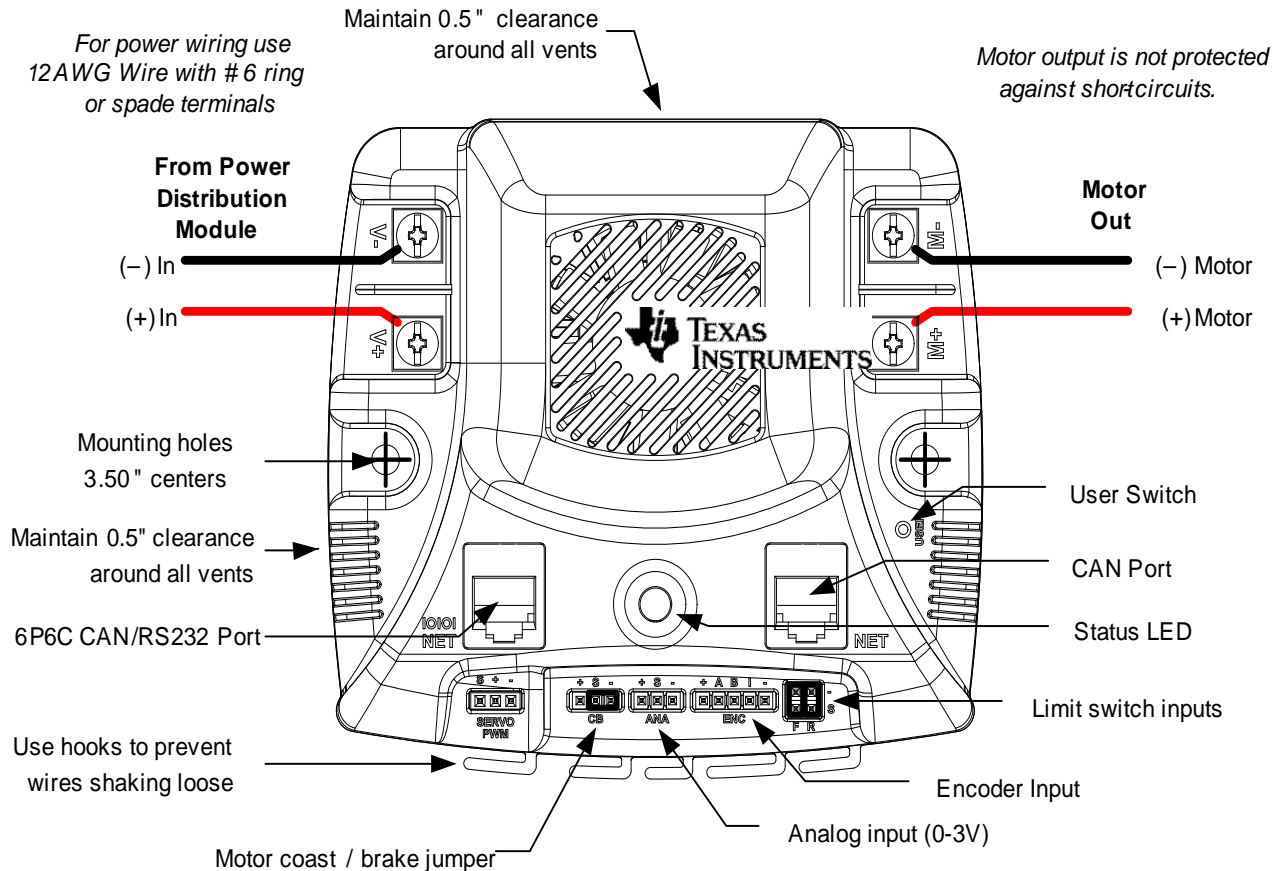

Reference Design Kit Contents

The RDK-BDC24 contains everything needed to evaluate brushed DC motor control. The RDK-BDC24 includes:

- MDL-BDC24 motor control module
 - Suitable for motors up to 24 V 40 A
 - Uses a Stellaris LM3S2616 microcontroller
- Mabuchi RS-555PH-3255 Brushed DC Motor
 - 5000 RPM, 12 V, 3 A
- Universal input wall power supply
 - 12 V 1.25 A

- Plug adaptors for US, UK, EU, and AUST
- DB9S to 6P6C adapter
 - Connects the MDL-BDC24 to a PC RS232 port
- 6P-6C modular cable 7-ft
 - Use for RS232 or CAN connection
- CAN terminator
 - Plug-in 120-Ω terminator
- Adapter cable for ARM JTAG/SWD fine-pitch header
 - Texas Instruments Part ADA2
- Reference design kit CD
 - Complete documentation, including Quickstart and user's guides
 - LM Flash Programmer utility for firmware updates
 - Complete source code, schematics, and PCB Gerber files

The source code can be modified and compiled using tools from Keil, IAR, CodeRed, CodeSourcery, GCC, and Code Composer Studio.

CHAPTER 2

Using the Reference Design Kit

This chapter provides information about using the RDK-BDC24.

Important Information

WARNING – In addition to safety risks, other factors that may damage the control hardware, the motor, and its load include improper configuration, wiring, or software. Minimize the risk of damage by following these guidelines.

- Always wear eye protection and use care when operating the motor.
- Read this guide before connecting motors other than the motor included in the RDK. DC motors may not be directly interchangeable and RDK parameter changes may be necessary before the new motor will operate correctly.
- Damage to the control board and motor can result from improper configuration, wiring, or software.

Developing with the RDK

The recommended steps for using the RDK are:

- **Follow the README First document included on the kit CD.** The README First document will help you get the RS-555 motor up and running using the BDC-COMM Windows application in just minutes. It also contains important safety information that you should read before using the RDK.
- **Use the BDC-COMM to evaluate and optimize target motor operation.** Once the module is installed in the end application, use the BDC-COMM to configure and monitor motor operation. Using RS232, the BDC-COMM gives real-time access to a range of operating parameters. The *MDL-BDC24 Getting Started Guide* covers module setup and use in customer applications.
- **Customize and integrate the software and/or hardware to suit an end application.** This user's manual and the *RDK-BDC24 Firmware Development Package User's Guide* are two important references for completing hardware and software modifications. New software can be programmed in the MDL-BDC24 using either BDC-COMM, or using a JTAG/SWD debug interface.

Power Supply Selection

The MDL-BDC24 is designed primarily for use with 12 V or 24 V sealed lead-acid batteries. Other power sources may be used as long as the MDL-BDC24's voltage range is not exceeded under any condition.

There are two important considerations when selecting a power supply. The first is specifying a supply that can supply the starting current of the motor. Even unloaded motors may have a starting current that can momentarily exceed 60 A. Some switching power supplies will shut down very

quickly when starting a brushed DC motor. The power supply does not need to maintain regulation during start, but it must ensure that the supply voltage remains above the under-voltage limit.

The second consideration is how the power supply handles back-EMF and regeneration currents. During rapid deceleration of loads with high inertia, the motor acts as a generator. This current is rectified by the MDL-BDC24 back into the bus capacitor. As the capacitor charges, the voltage at the supply terminals may increase. It is important that the power supply can handle this momentary condition without entering a fault condition. The power supply must also present sufficiently low impedance so that the MDL-BDC24's voltage rating is not exceeded. A sealed lead acid battery easily meets these requirements.

NOTE: The MDL-BDC24 does not have reverse polarity input protection.

Motor Selection

The MDL-BDC24 operates 12 V to 24 V brushed DC motors. Typical motors include model BI802-001A from CIM and model RS-555PH-3255 from Mabuchi (see Table 2-1 for motor specifications). Some very small DC motors or motors in lightly loaded applications may have a limited useful speed range when controlled with PWM based voltage controls.

The MDL-BDC24 can also drive resistive loads with some de-rating to allow for increased ripple current inside the module. See the MDL-BDC24 board data sheet for full specifications.

Table 2-1. Mabuchi RS-555PH-3255 Motor Specifications

Parameter	Value	Units
At maximum efficiency		
Speed	3953	RPM
Current	1.244	A
Power	7.139	W
Torque	17.25	mMm
At maximum power		
Speed	2325	RPM
Current	3.627	A
Power	14	W
Torque	57.5	mMm
General characteristics		
No load speed	4650	RPM
No load current	0.223	A

Firmware Updates and Debugging

The MDL-BDC24 supports two methods for updating the firmware resident in the LM3S2616 microcontroller. The primary method, commonly used for field updates, uses the CAN or RS232 interface and a Flash-resident boot loader for firmware transfer. During actual firmware development, direct access and debug capability is preferable. The MDL-BDC24 included in the RDK has a JTAG/SWD connector installed for this purpose.

General Information

StellarisWare firmware revisions are referenced using four-digit numbers that increase with new releases, but are not necessarily contiguous (that is, numbers may be skipped).

The flash memory region between 0x0000 and 0x07FF contains a CAN/RS232 boot loader. The main firmware image should be loaded at 0x0800.

Firmware Update Using RS232/CAN

The MDL-BDC24 firmware can be updated over RS232 or CAN using the BDC-COMM utility and the cables included in the reference design kit. See the *MDL-BDC24 Getting Started Guide* for step-by-step instructions.

Firmware Update and Debugging Using JTAG/SWD

The MDL-BDC24 included in the RDK has a 2 x 5 fine-pitch header installed for firmware programming and debugging using JTAG/SWD. JTAG is a four-wire interface. SWD is a high-performance, two-wire interface with similar capabilities. Figure 3-1 on page 15 shows how to locate the JTAG/SWD connector.

Figure 3-1. Locating the JTAG/SWD Connector

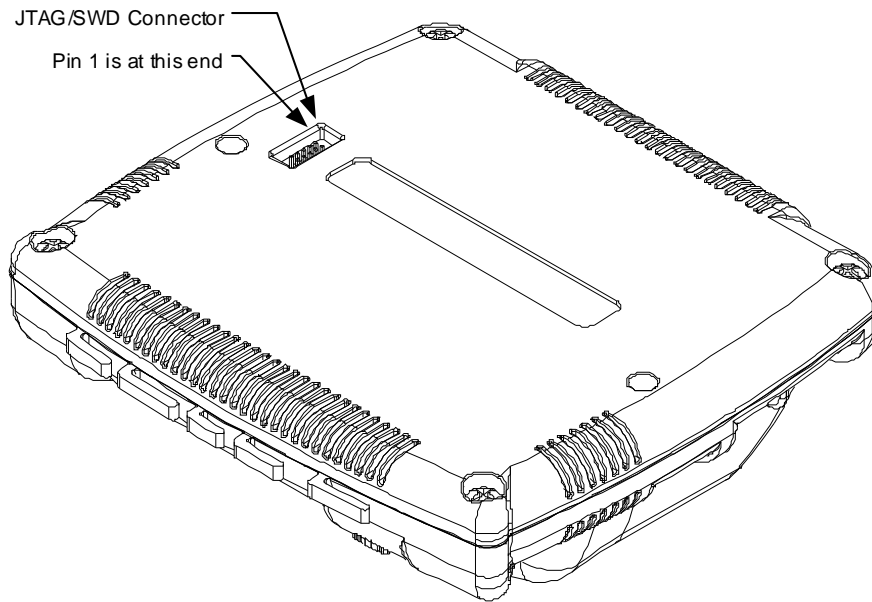

When using the JTAG/SWD cable, pay special attention to the location of pin 1 on the connector. When inserted correctly, the cable runs back across the bottom of the case, covering the rectangular inset. See Chapter 4, “Hardware Description,” for additional information on the JTAG/SWD connector.

Any Stellaris evaluation boards can be used as a low cost In-circuit Debug Interface (ICDI) for both programming and debugging. The ICDI circuit is compatible with LM Flash Programmer as well as leading development tools for ARM® Cortex™-M3. Evaluation versions for several tools are available from www.ti.com/stellaris.

Figure 3-2. Firmware Debugging Using JTAG/SWD

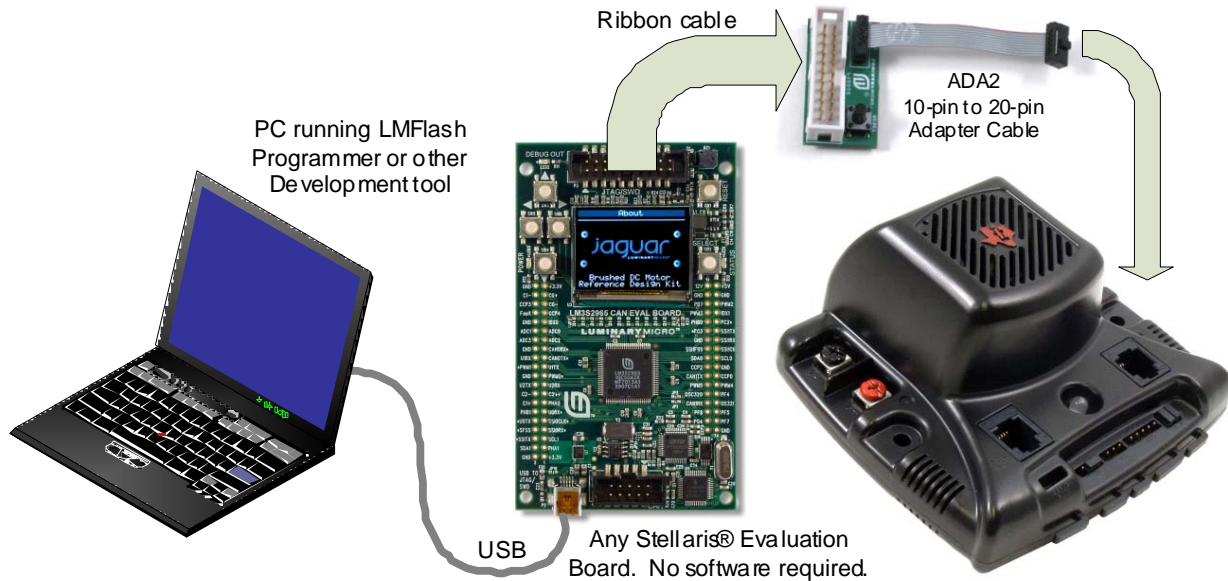

CHAPTER 4

Hardware Description

The MDL-BDC24 motor control module uses a highly integrated Stellaris LM3S2616 microcontroller to handle PWM synthesis, analog sensing, and the CAN/RS232 interface. Only a few additional ICs are necessary to complete the design. The entire circuit is built on a simple two-layer printed circuit board. All design files are provided on the RDK CD.

System Description

A unique aspect of the MDL-BDC24 design is the integrated CAN interface and low-cost, fan-cooled MOSFET array that handles high current in a small form-factor. The motor control consists of an H-bridge arrangement which is driven by fixed-frequency PWM signals.

Key Hardware Components

Figure 4-1 shows the MDL-BDC24 circuit board with the enclosure and cooling fan removed.

Figure 4-1. MDL-BDC24 Circuit Board

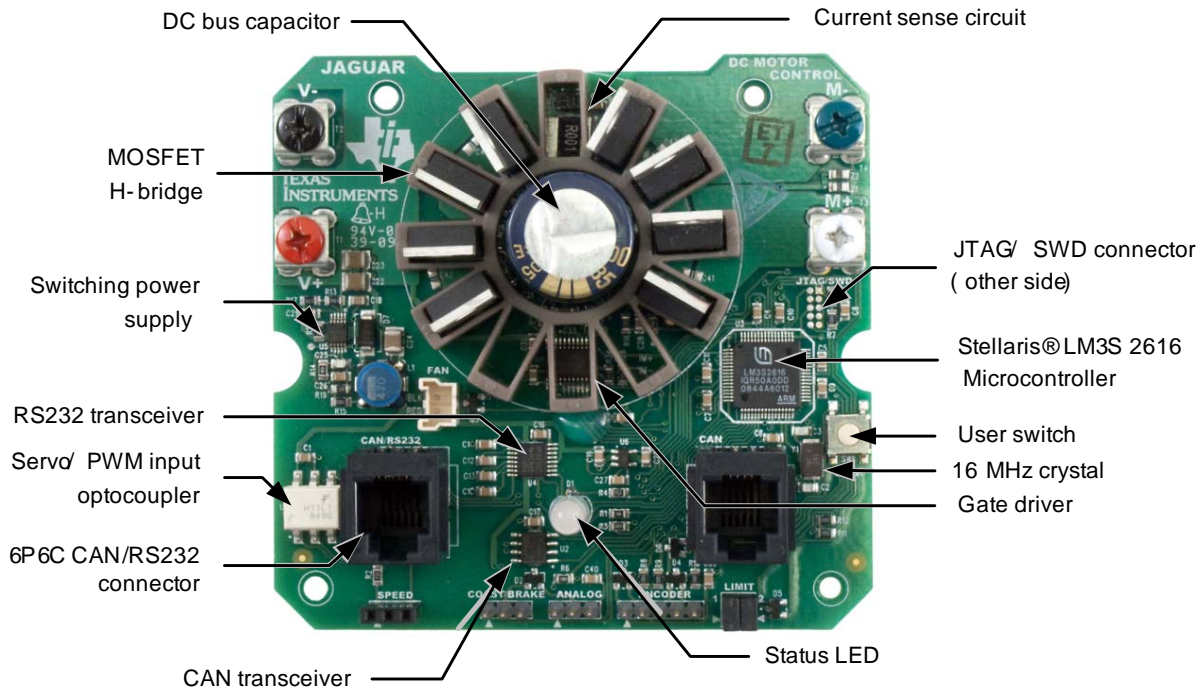

Schematic Description

Microcontroller, CAN, and I/O Interfaces (Schematic page 1)

Page 1 of the schematics shows the microcontroller, CAN port, RS232 port, and sensor interfaces in detail.

Microcontroller

At the core of the MDL-BDC24 is a Stellaris LM3S2616 microcontroller. The LM3S2616 contains a peripheral set that is optimized for networked control of motors, including 6 high-speed ADC channels, a motor control PWM block, a quadrature encoder input, as well as a CAN module.

The microcontroller's PWM module can generate two complementary PWM signal pairs that are fed to the power stage. Complementary PWMs are important for synchronous rectification (see "Output Stage and Power Supplies (Schematic page 2)" on page 19).

The LM3S2616 has an internal LDO voltage regulator that supplies 2.5 V power for internal use. This rail requires only three capacitors for decoupling and is not connected to any other circuits.

Clocking for the LM3S2616 is facilitated by a 16 MHz crystal. Although the LM3S2616 can operate at up to 50 MHz, in order to minimize power consumption, the PLL is not enabled in this design. The 32-bit Cortex-M3 core has ample processing power to support all features including 1 Mbits/s CAN and RS232 with a clock speed of 16 MHz.

Debugging

The microcontroller supports JTAG and SWD debugging as well as SWO trace capabilities. To minimize the board area, the MDL-BDC24 uses a 0.050" pitch header footprint which matches ARM's fine-pitch definition (Figure 4-2). The connections are located on the bottom of the module, under the serial number label. The module included in the reference design kit has a header installed; however, the standard MDL-BDC24 (available as a separate item) does not have the header installed.

Some in-circuit debuggers provide a matching connector. Other ARM debuggers can be used with the adapter board included in the RDK.

Figure 4-2. MDL-BDC24 JTAG/SWD Connector

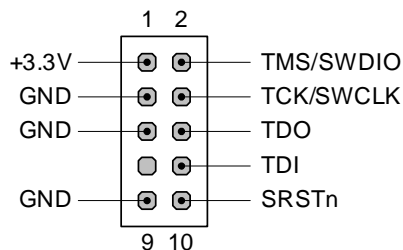
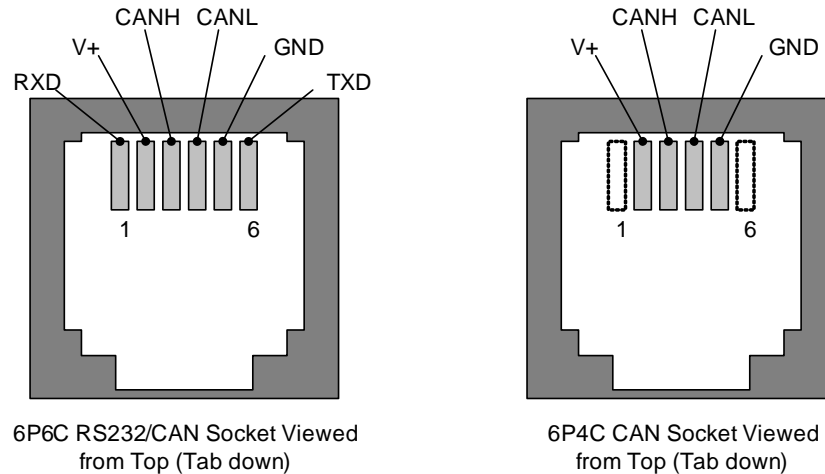

Figure 4-2 shows the pin assignments for the JTAG/SWD connector as viewed from the bottom (connector) side of the circuit board.

CAN Communication

A key feature of the LM3S2616 microcontroller is its CAN module that enables highly reliable communications at up to 1 Mbits/s. The MDL-BDC24 control board uses a Texas Instruments SN65HVD1050D CAN transceiver (U2), additional ESD protection (D6), and connectors. The pin assignments for the 6P6C/6P4C connectors are defined in CAN in Automation (CiA DS102). Figure 4-3 shows the network connector pin assignments.

Figure 4-3. Network Connector Pin Assignments

The V+ signal (Pin 2) is not used in the MDL-BDC24, however, it is passed through to support other devices that either provide or use power from this terminal. The typical application for V+ is in providing a small amount of power to optocouplers for isolating CAN signals.

For 1-Mbps CAN communication over distances up to 20 feet, the network should be terminated at each end with a 100Ω resistor. This value is slightly lower the normal 120Ω terminator, but it accelerates the bus' return to the recessive state which is important in high-data rate, high node-count applications.

RS232 Communication

The MDL-BDC24 supports a full set of network control and configuration functions over a standard RS232C serial interface. The command protocol is essentially the same as the protocol used on the CAN interface, thereby allowing the MDL-BDC24 to automatically bridge all commands between the RS232 and CAN interfaces.

A TRS3221E RS232 transceiver was selected to translate the CMOS logic levels from the LM3S2616's UART0 to RS232 levels. Its internal charge-pump generates positive and negative voltages from the +5 V supply pin. Integrated ESD protection means that no external protection device is necessary.

Other Interfaces

Interfaces for an encoder (or tachometer), limit switches, and brake control are provided on 0.1" pin headers. The connections to the microcontroller are ESD-protected and in most cases have 10 kΩ pull-up resistors.

The brake and user switch inputs use the LM3S2616 microcontroller's internal pull-up resistor.

The analog input has a 0 to 3 V span. In order to use a 10 kΩ potentiometer, a 1 kΩ "padding" resistor is provided on J4.1 to drop 300 mV from the 3.3 V rail when the potentiometer is connected.

Output Stage and Power Supplies (Schematic page 2)

Page 2 of the schematics details the power supplies, gate drivers, output transistors, sensing, and fan control circuits.

Motor Output Stage

The motor output stage consists of an H-bridge with High-/Low-side gate drivers. Each leg of the H-bridge has two paralleled MOSFETs. The MOSFETs are connected in parallel to reduce total $R_{ds(on)}$ to about $2.5\text{ m}\Omega$ and to provide additional surface area for fan cooling. The fan blows directly on the TO-220 MOSFETs, which are arranged radially around the DC bus capacitor. A plastic ring encompasses the MOSFETs providing mechanical support and ensuring that the tabs do not touch.

The gate driver provides high peak currents to rapidly switch the gates of the MOSFETs when directed by the microcontroller's PWM module. An internal charge-pump allows the drivers to maintain MOSFET gate voltage, even under low-voltage conditions. Resistor R34 sets the gate drive dead-time to approximately $2\mu\text{s}$.

Because the high-side MOSFETs are N-Channel types, a positive V_{gs} is required to switch them on. The gate driver uses a simple boot-strapping technique to ensure that the high-side V_{gs} remains above the $V_{gs(on)}$ threshold. Whenever the low-side MOSFETs are on, the associated boot-strap capacitor (C34 or C36) charges from the internal charge-pump regulator. Later, when the high-side MOSFETs turn on, the boot-strap capacitor maintains power to the high-side driver with respect to the Motor terminal.

One restriction with the boot-strap capacitor method is that the capacitor voltage will decay to an unacceptable level unless a low-side MOSFET is periodically switched on. This state only occurs when the motor is running full-forward or full-reverse. The gate driver has an internal sense circuit that inserts small low-side pulses whenever the bootstrap voltage decays. The short duration has no measurable impact on motor speed. The boot-strap monitor capability is the reason that the gate driver controls dead-time rather than the LM3S2616 microcontroller.

Switching Scheme

To reduce power dissipation in the H-bridge, the MDL-BDC24 uses synchronous rectification. Synchronous rectification uses the complementary MOSFET, rather than a diode, to provide a low-resistance current path during the PWM off period.

Figure 4-4 shows the current paths through a complete PWM_ON, Dead-time, PWM_OFF cycle. The motor is modelled primarily as an inductor.

During the PWM_ON period, Q1 on the high-side and Q2 on the low-side provide a path that increases current in the motor.

The $2\mu\text{s}$ DEAD_TIME period starts with Q1 turning OFF. Current continues to flow through the load, with the path being completed by the Q2 intrinsic diode and Q4. The voltage drop across Q2 is equal to a forward-biased diode.

Next, the synchronous rectification period, PWM_OFF, occurs when Q2 is ON. The voltage drop across Q2 is now greatly reduced. The load current decays during this period.

Figure 4-4. Synchronous Rectification

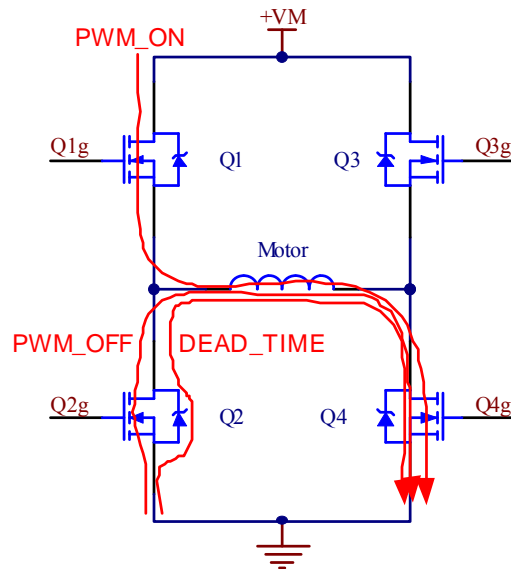

During PWM_OFF, assuming a 40 A load, Q2 losses are approximately 40W without synchronous rectification. This drops to just 4W if synchronous rectification is used ($R_{ds-on} = 2.5 \text{ m}\Omega$). Synchronous rectification significantly improves drive-stage efficiency, particularly at lower duty cycles (50% and less) when the PWM_OFF time is longer than the PWM_ON time.

Power Supply

The MDL-BDC24 uses a TPS54040-based switching power supply for optimal efficiency over a wide operating range. Resistor R20 sets the switching frequency at around 700kHz, which allows the use of a small inductor and output capacitor.

The 5-V rail is used for the cooling fan, CAN and RS232 transceivers, current sense amplifier, and quadrature encoder functions. A low drop-out voltage linear regulator (TPS73633) generates the 3.3-V rail which is used by the MCU and peripheral circuitry.

Current Sensing

The current sensing circuit consists of a high-side shunt resistor (R23) and a specialized current sense amplifier (INA193). Due to the high current capabilities of the bridge, the shunt resistor is just $1 \text{ m}\Omega$. The INA193 amplifier has a fixed gain of 20 V/V which results in a signal into the ADC of 20 mV/A for a full-scale reading of 150 A. Because the sense resistor is in the high-side of the H-bridge, the current through it is only positive when the high-side MOSFETs are on. The MDL-BDC24 software takes this into consideration when sampling the current waveform.

When operating smaller motors, or lightly-loaded large motors, the INA193 may be operating with a V_{sense} less than 20 mV. This region has reduced current sense amplifier accuracy. See the INA193 data sheet for full details on Low V_{sense} Case 1 and Case 3.

The PCB design has an option to populate an INA282 current sense amplifier. This was done to evaluate a future build option. The INA282 and supporting components are omitted from the assembly.

Voltage Sensing

A simple divider resistor network (16 and R18) scales the V_{bus} rail down to the range of the ADC (0-3 V). The full-scale ADC measurement (ADC=1023) corresponds to a bus voltage of 36 V.

Fan Control

The cooling fan is self-contained and uses a small, 5 V brushless DC motor. The MDL-BDC24 supports On/Off software control of the fan using Q3. The fan operates when the motor is running or when the temperature exceeds a certain threshold. The LM3S2616 microcontroller has an internal temperature sensor and a simple software table correlates the microcontroller temperature to the overall system temperature.

Texas Instruments' Featured Parts

The MDL-BDC24 features a range of semiconductors from Texas Instruments as shown in Table 4-1.

Table 4-1. Detailed List of Texas Instruments' Featured Parts

Part Number	Description	Use	Features
LM3S2616	Stellaris® Microcontroller	System control	<ul style="list-style-type: none"> ARM® Cortex™-M3 core Motion control capabilities 64 KB Flash.
SN65HVD1050	High-Speed EMC Optimized CAN Transceiver	CAN communications	<ul style="list-style-type: none"> High electromagnetic immunity (EMI) Very low electromagnetic emissions (EME) Bus-fault protection of -27 V to 40 V Dominant time-out function Power-up/down glitch-free bus inputs and outputs
TRS3221E	Single-Channel RS-232 Compatible Line Driver/Receiver	RS232 communications	<ul style="list-style-type: none"> Operates up to 250 kbits/sec Low standby current... 1 μA Typ External Capacitors... 4 \times 0.1 μF RS-232 bus-pin ESD protection exceeds \pm15 kV using human-body model (HBM)
TPS54040	0.5 A Step Down SWIFT™ Converter with Eco-Mode™	5V Power Supply	<ul style="list-style-type: none"> 3.5 V to 42 V input voltage range 200-mΩ high-side MOSFET High efficiency at light loads with a pulse skipping Eco-Mode™ 100 kHz to 2.5 MHz switching frequency
TPS73633	Cap-Free, NMOS, 400 mA LowHDropout Regulator with Reverse Current Protection	3.3V Power Supply	<ul style="list-style-type: none"> Stable with no output capacitor or any value or type of capacitor Input voltage range of 1.7 V to 5.5 V Ultra-low dropout voltage: 75 mV typ Excellent load transient response Low reverse leakage current Low noise: 30 μV RMS typ (10 Hz to 100 kHz) 0.5% initial accuracy
INA193	Voltage Output High-Side Measurement Current Shunt Monitor	Motor current measurement	<ul style="list-style-type: none"> Wide common-mode voltage -16 V to +80 V Low error 3.0% over temp (max) Wide bandwidth: up to 500 kHz Low quiescent current 900 μA (max) Complete current sense solution

Schematics

This section contains the schematic diagrams for the RDK-BDC24.

- MCU, Network, and Interface on page 24
- Power Supplies and Output Stage on page 25

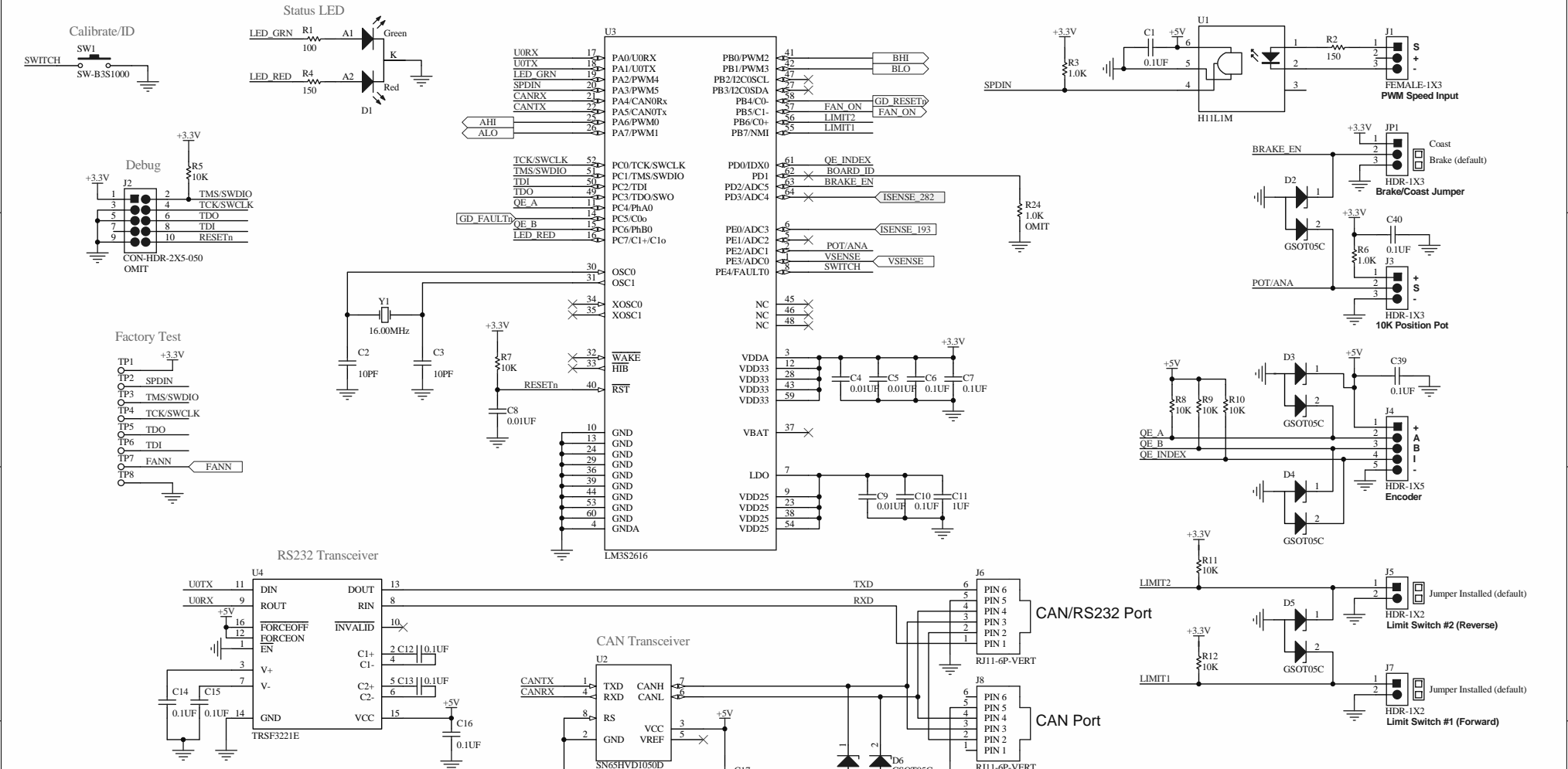

Revision	Date	Description
0	Sept 9, 09	Internal Prototype
A	Sept 11, 09	Pre-production. See Round-up for change list
A1	Sept 14, 09	Change to use conventional Isense resistors.
B	Sept 21, 09	Pre-production release.
	Oct 7, 09	Adjust Isense and SMPS circuit values.
C	Sept 9, 10	Added INA282 current sense circuit as a future build option. INA282 parts are omitted.

TEXAS INSTRUMENTS TI AEC - Austin 108 Wild Basin Rd. Suite 350 Austin, TX 78746		
		Designer: DAY, JAG, KAK
Drawn by: DAY, JAG, KAK	Page Title: MCU, Network and Interface	
Approved: *	Size B	Document Number: *
Date: 9/10/2010		Sheet 1 of 2

12-24V POWER IN

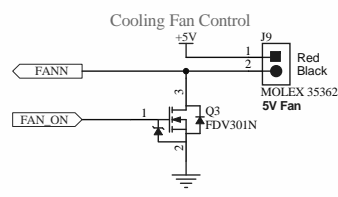
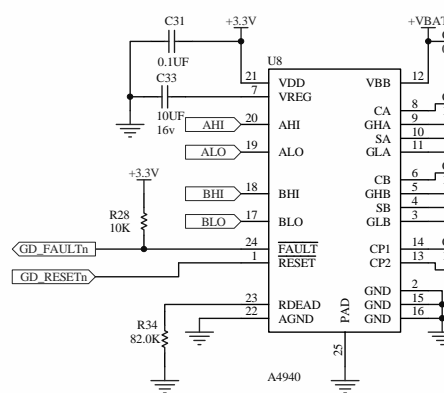
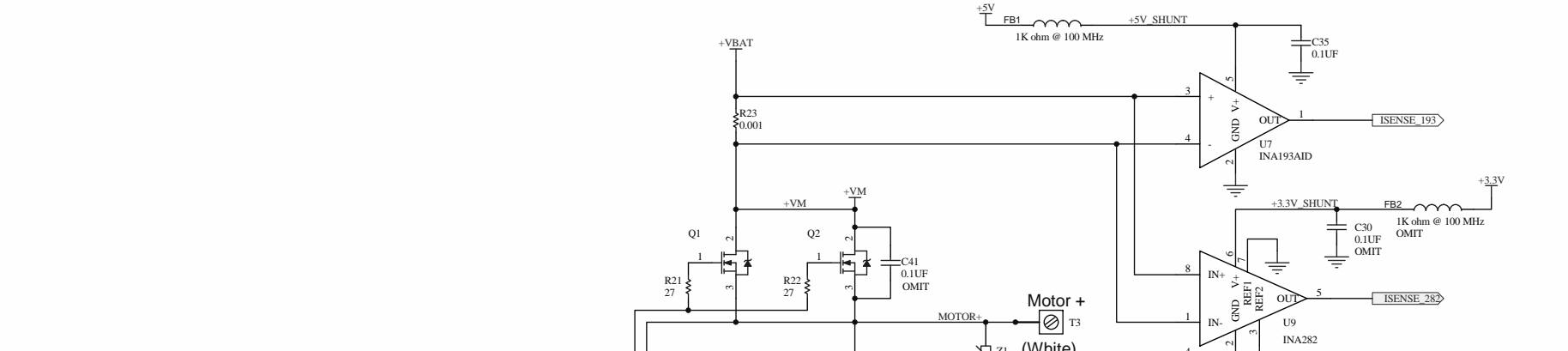
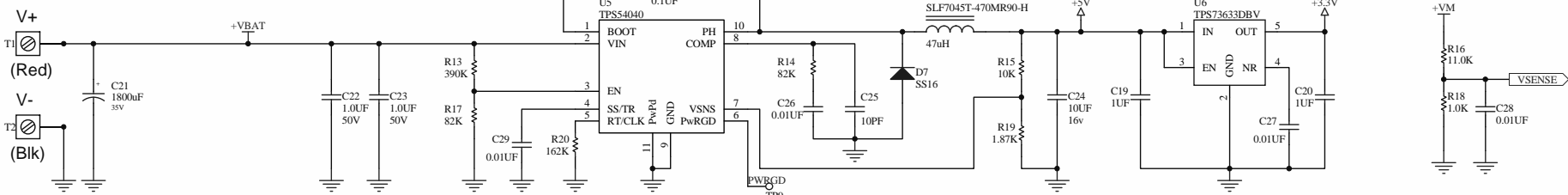

 TEXAS INSTRUMENTS		
Drawing Title: Black Jaguar Brushed DC Motor Control		
Page Title: Power Supplies and Output Stage		
Size B	Document Number: *	Rev C
Date: 9/10/2010	Sheet 2	of 2

APPENDIX B

Board Drawing

This appendix shows the component placement plot for top (Figure B-1)

Figure B-1. Component Placement Plot

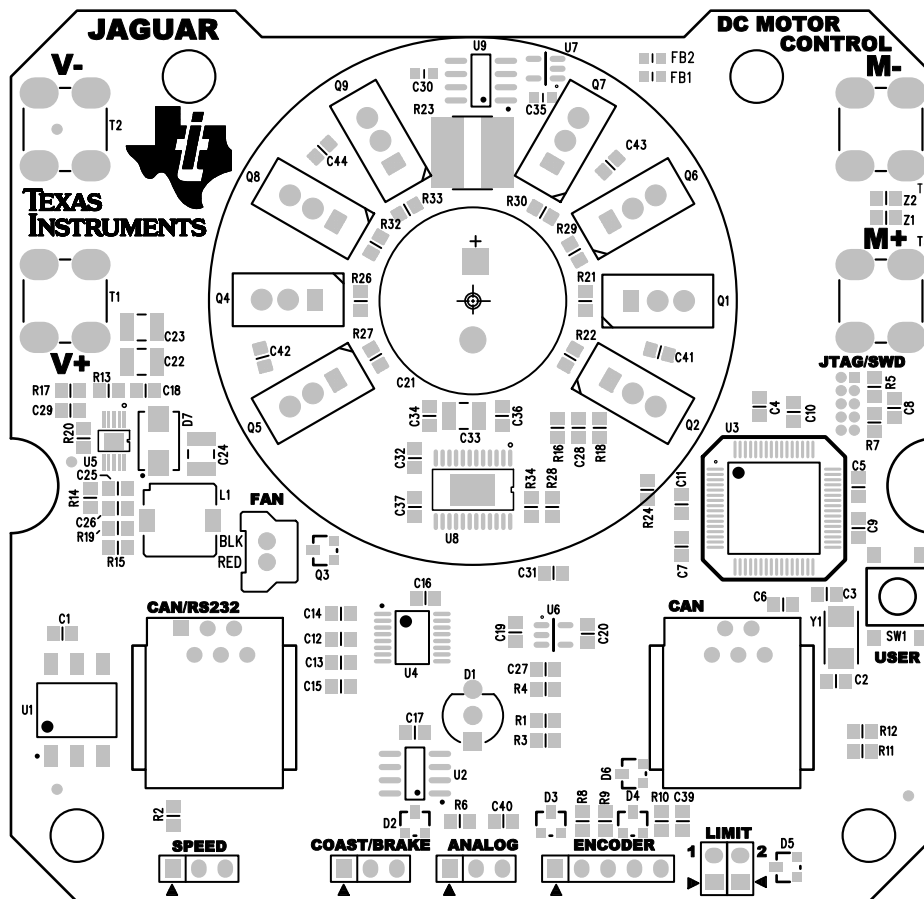

A P P E N D I X C

Bill of Materials (BOM)

Table C-1 provides the BOM for the RDK-BDC24.

Table C-1. RDK-BDC24 Bill of Materials (BOM)

Texas Instruments Part Number RDK-BDC24
 BD-BDC24 Final Assembly BOM (PCB Assembly + Enclosure)
 Bill Of Materials Created 11/11/2010

Item	Ref	Qty	Description	Mfg	Part Number
1	C1, C6, C7, C10, C12, C13, C14, C15, C16, C17, C18, C31, C32, C39, C40	15	Capacitor, 0.1uF 50V, 20% 0805 X7R	Kemet	C0805C104M5RACTU
2	C11, C19, C20, C34, C36, C37	6	Capacitor, 1.0uF 25V 10% X5R 0805	Taiyo Yuden	TMK212BJ105KG-T
3	C2, C3, C25	3	Capacitor 10pF 50V 5% 0805 COG	Kemet	C0805C100J5GACTU
4	C21	1	Capacitor, 1800uF 35V 20% 18mmx20mm	Panasonic	EEU-FC1V182S
5	C22, C23	2	Capacitor, 2.2uF 50V 10% X7R 1210	Kemet	C1210C225K5RACTU
6	C24, C33	2	Capacitor, 10uF 16V 10% X7R 1210	Murata	GRM32DR71C106KA01L
7	C35	1	Capacitor, 0.1uF 50V, 20% 0603 X7R	Kemet	C0603C104M5RACTU
8	C4, C5, C8, C9, C26, C27, C28, C29	8	Capacitor, 0.01uF 50V, 5% 0805 X7R	Kemet	C0805C103J5RACTU
9	D1	1	LED, Green, Red, 5mm T-hole, dual	Kingbright Corp	WP59SRSGW/CC
10	D1b	1	SPACER, PCB-LED T1-3/4, 109Mil	Keystone	8902
11	D2, D3, D4, D5, D6	5	Diode, 2 Line 5V ESD Suppressor SOT-23	Vishay ON Semiconductor	GSOT05C-GS08 SM05T1G
12	D7	1	Diode, Schottky, 60V, 1A	Vishay	SS16-E3/61T
13	FB1	1	Ferrite Bead, 400mA, 1K Ohm@100Mhz	Murata	BLM18AG102SN1D
14	J1	1	Header, 1x3, 0.100, T-Hole, Vertical, Female	4UCON Sullins	00523 PPTC031LFBN-RC
15	J3, JP1	2	Header, 1x3, 0.100, T-Hole, Vertical Unshrouded, 0.230 Mate	4UCON FCI	00798 68001-103HLF
16	J4	1	Header, 1x5, 0.100, T-Hole, Vertical Unshrouded, 0.230 Mate	4UCON FCI	00806 68000-105HLF
17	J5, J7 (Combined)	1	Header, 2x2, 0.100, T-Hole, Vertical Unshrouded, 0.230 Mate	4UCON FCI	00998 67997-104HLF
18	J6	1	Connector, RJ11 Mod-Jack 6-6 Vert Flange Blk	FCI 4UCON	90512-001LF 04912
19	J8	1	Connector, RJ11 Mod-Jack 6-4 Vert Flange Blk	FCI 4UCON	90512-003LF 04911
20	J9	1	Header, 1x2 Surelock 2mm, Thole Vertical, shrouded	Molex	35362-0250
21	L1	1	Inductor 47uH, SMD 7mmx7mm, 0.9A, 0.18Ohm	TDK	SLF7045T-470MR90-H
22	PCB1	1	PCB, RDK, DD, BlackJag Rev C	Advanced Circuits	RDK-BDC24 Rev C
23	Q1, Q2, Q4, Q5, Q6, Q7, Q8, Q9	8	MOSFET N-CH, TO-220 40V/60V 80A	Fairchild	FDP050AN06A0
24	Q3	1	MOSFET, N-CH, SOT-23, 25V, 220mA	Fairchild	FDP038AN06A0 FDV301N
25	R1	1	Resistor, 100 OHM 1/8W 5% 0805 Thick	Panasonic	ERJ-6GEYJ101V
26	R13	1	Resistor, 390K Ohm, 1/8W, 1% 0805 Thick	Vishay	CRCW0805390KFKEA
27	R14, R17	2	Resistor, 82K OHM 1/8W 5% 0805 Thick	Panasonic	ERJ-6GEYJ823V

Table C-1. RDK-BDC24 Bill of Materials (BOM) (continued)

Texas Instruments
 BD-BDC24 Final Assembly BOM (PCB Assembly + Enclosure)
 Bill Of Materials

Part Number RDK-BDC24
 Created 11/11/2010

Item	Ref	Qty	Description	Mfg	Part Number
28	R16	1	Resistor, 11K Ohm, 1/8W, 1% 0805 Thick	Panasonic	ERJ-6ENF1102V
29	R19	1	Resistor, 1.87K Ohm, 1/8W, 1% 0805 Thick	Yageo	RC0805FR-071K87L
30	R2, R4	2	Resistor, 150 OHM 1/8W 5% 0805 Thick	Panasonic	ERJ-6GEYJ151V
31	R20	1	Resistor, 162K Ohm, 1/8W, 1% 0805 Thick	Rohm	MCR10EZPF1623
32	R21, R22, R26, R27, R29, R30, R32, R33	8	Resistor, 27 OHM 1/8W 5% 0805 Thick	Panasonic	ERJ-6GEYJ270V
33	R23	1	Resistor, 0.001 OHM, 4W 1% 2725 SMD	Stackpole Electronics	CSS2725FT1L00
34	R3, R6, R18	3	Resistor, 1K Ohm, 1/8W, 1% 0805 Thick	Panasonic	ERJ-6ENF1001V
35	R34	1	Resistor, 47K OHM 1/8W 5% 0805 Thick	Rohm	MCR10EZPJ473
36	R5, R7, R8, R9, R10, R11, R12, R15, R28	9	Resistor, 10K Ohm, 1/8W, 1% 0805 Thick	Panasonic	ERJ-6ENF1002V
37	SW1	1	Switch, Tact 6mm SMT, 160gf	Omron	B3S-1000P
38	T1	1	Terminal, Screw Vertical 15A Red Screw - non captive	Keystone	8191-2
39	T2	1	Terminal, Screw Vertical 15A Black Screw - non captive	Keystone	8191-3
40	T3	1	Terminal, Screw Vertical 15A White Screw - non captive	Keystone	8191-4
41	T4	1	Terminal, Screw Vertical 15A Green Screw - non captive	Keystone	8191-6
				Fairchild	H11L1SR2M
				Fairchild	H11L1SR2VM
43	U2	1	CAN Transceiver 8-SOIC	Texas Instruments	SN65HVD1050D
44	U3	1	Stellaris, LM3S2616-IQR50-A0	Texas Instruments	LM3S2616-IQR50-A0
				Texas Instruments	TRS3221ECPWR
				Texas Instruments	MAX3221ECPW
46	U5	1	Regulator, SWIFT, Step Down, 0.5A, 42V, MSOP10	Texas Instruments	TPS54040DGO
47	U6	1	Regulator, Linear, 3.3V, SOT23-5 (DBV)	Texas Instruments	TPS73633DBV
48	U7	1	Current Shunt Monitor, INA193, 20V/V Gain, 5SOT-23	Texas Instruments	INA193AIDBVR
49	U8	1	Full Bridge MOSFET Driver, Allegro, 24-eTSSOP	Allegro	A4940KLPT-R
				NDK	NX5032GA-16.000000MHZ
				Abracon	ABM3-16.000MHZ-B2-T
51	Z1, Z2	2	TVS Varistor, 30V, 30A, Transguard	AVX	VC080530A650DP

PCB Do Not Populate List (Shown for information only)

52	C30	1	Capacitor, 0.1uF 50V, 20% 0603 X7R	Kemet	C0603C104M5RACTU
53	C41, C42, C43, C44	4	Capacitor, 0.1uF 50V, 20% 0805 X7R	Kemet	C0805C104M5RACTU
54	FB2	1	Ferrite Bead, 400mA, 1K Ohm@100Mhz	Murata	BLM18AG102SN1D
55	J2	1	Header 2x5, 0.050 (1.27mm), TH, Vertical Unshrouded	Harwin	M50-3500542
56	R24	1	Resistor, 1K Ohm, 1/8W, 1% 0805 Thick	Panasonic	ERJ-6ENF1001V
57	U9	1	Current Shunt Monitor, INA282, 50V/V Gain, Zer0 Drift, 8SOIC	Texas Instruments	

Table C-1. RDK-BDC24 Bill of Materials (BOM) (continued)

Texas Instruments Part Number RDK-BDC24
 BD-BDC24 Final Assembly BOM (PCB Assembly + Enclosure)
 Bill Of Materials Created 11/11/2010

Final Assembly Bill Of Materials

Item	Ref	Qty	Description	Mfg	Part Number
58	JP1b, J5b, J7b	3	Jumper, 0.100, Gold, Black, Closed	Sullins	SPC02SYAN
59		1	Fan Assembly, 40x40x10mm, 5V, 5.3CFM, 2" Lead w/ Molex Sherlock connector	ebmpapst	405 FH
				SUNON	KDE0504PFV2
60		1	Enclosure, ABS plastic 3 pieces	Cypress	LM-608-01
61		1	Label, with Model/Serial/Firmware info	Anyone	BJAG-LABELS
62		4	Screw, #4 x 0.375" plastite (for enclosure)	McMaster	90380A108
63		4	Screw, #4 x 0.625" Pan Head, Sheet Metal, Phillips/Slotted (for fan)	McMaster	90077A112

IMPORTANT NOTICE

Texas Instruments Incorporated and its subsidiaries (TI) reserve the right to make corrections, modifications, enhancements, improvements, and other changes to its products and services at any time and to discontinue any product or service without notice. Customers should obtain the latest relevant information before placing orders and should verify that such information is current and complete. All products are sold subject to TI's terms and conditions of sale supplied at the time of order acknowledgment.

TI warrants performance of its hardware products to the specifications applicable at the time of sale in accordance with TI's standard warranty. Testing and other quality control techniques are used to the extent TI deems necessary to support this warranty. Except where mandated by government requirements, testing of all parameters of each product is not necessarily performed.

TI assumes no liability for applications assistance or customer product design. Customers are responsible for their products and applications using TI components. To minimize the risks associated with customer products and applications, customers should provide adequate design and operating safeguards.

TI does not warrant or represent that any license, either express or implied, is granted under any TI patent right, copyright, mask work right, or other TI intellectual property right relating to any combination, machine, or process in which TI products or services are used. Information published by TI regarding third-party products or services does not constitute a license from TI to use such products or services or a warranty or endorsement thereof. Use of such information may require a license from a third party under the patents or other intellectual property of the third party, or a license from TI under the patents or other intellectual property of TI.

Reproduction of TI information in TI data books or data sheets is permissible only if reproduction is without alteration and is accompanied by all associated warranties, conditions, limitations, and notices. Reproduction of this information with alteration is an unfair and deceptive business practice. TI is not responsible or liable for such altered documentation. Information of third parties may be subject to additional restrictions.

Resale of TI products or services with statements different from or beyond the parameters stated by TI for that product or service voids all express and any implied warranties for the associated TI product or service and is an unfair and deceptive business practice. TI is not responsible or liable for any such statements.

TI products are not authorized for use in safety-critical applications (such as life support) where a failure of the TI product would reasonably be expected to cause severe personal injury or death, unless officers of the parties have executed an agreement specifically governing such use. Buyers represent that they have all necessary expertise in the safety and regulatory ramifications of their applications, and acknowledge and agree that they are solely responsible for all legal, regulatory and safety-related requirements concerning their products and any use of TI products in such safety-critical applications, notwithstanding any applications-related information or support that may be provided by TI. Further, Buyers must fully indemnify TI and its representatives against any damages arising out of the use of TI products in such safety-critical applications.

TI products are neither designed nor intended for use in military/aerospace applications or environments unless the TI products are specifically designated by TI as military-grade or "enhanced plastic." Only products designated by TI as military-grade meet military specifications. Buyers acknowledge and agree that any such use of TI products which TI has not designated as military-grade is solely at the Buyer's risk, and that they are solely responsible for compliance with all legal and regulatory requirements in connection with such use.

TI products are neither designed nor intended for use in automotive applications or environments unless the specific TI products are designated by TI as compliant with ISO/TS 16949 requirements. Buyers acknowledge and agree that, if they use any non-designated products in automotive applications, TI will not be responsible for any failure to meet such requirements.

Following are URLs where you can obtain information on other Texas Instruments products and application solutions:

Products

Audio	www.ti.com/audio
Amplifiers	amplifier.ti.com
Data Converters	dataconverter.ti.com
DLP® Products	www.dlp.com
DSP	dsp.ti.com
Clocks and Timers	www.ti.com/clocks
Interface	interface.ti.com
Logic	logic.ti.com
Power Mgmt	power.ti.com
Microcontrollers	microcontroller.ti.com
RFID	www.ti-rfid.com
RF/IF and ZigBee® Solutions	www.ti.com/lprf

Applications

Communications and Telecom	www.ti.com/communications
Computers and Peripherals	www.ti.com/computers
Consumer Electronics	www.ti.com/consumer-apps
Energy and Lighting	www.ti.com/energy
Industrial	www.ti.com/industrial
Medical	www.ti.com/medical
Security	www.ti.com/security
Space, Avionics and Defense	www.ti.com/space-avionics-defense
Transportation and Automotive	www.ti.com/automotive
Video and Imaging	www.ti.com/video
Wireless	www.ti.com/wireless-apps

TI E2E Community Home Page

e2e.ti.com

Mailing Address: Texas Instruments, Post Office Box 655303, Dallas, Texas 75265
Copyright © 2011, Texas Instruments Incorporated