

RANGE COMPOSITION

Chilling means bringing the temperature of cooked food from +90°C to +3°C in a short time lap to minimize bacteria proliferation and avoid loss of food consistency and texture. The ZANUSSI easyChill Blast Chillers reduce temperature to +3°C at food core in less than 90 minutes. After the Blast Chilling a holding cycle starts automatically to maintain food at +3°C. Blast chilled food has a solid 5 days shelf life without loss of flavour, nutritional values and weight. The opportunity to prepare in a single shot the food to be used in different times during the week enables a better work scheduling and therefore a sensible reduction in labour costs.



110001

100 KG 20 GN 1/1

ACTIVE BLAST CHILLERS **ZANUSSI** PROFESSIONAL

FUNCTIONAL AND CONSTRUCTION FEATURES

- ◆ Soft Chilling (Air temperature -2°C).
- ◆ Hard Chilling (Air temperature -12°C).
- ◆ All the probe-driven cycles feature ARTE (Algorithm for Remaining Time Estimation): the machine displays the actual time needed to end the cycle and to make planning the activities easier.
- ◆ Holding at +3°C (automatically activated at the end of each cycle).
- ◆ Turbo cooling: the chiller works continuously at the desired temperature. Ideal for continuous production and for pastry application.
- ◆ Automatic recognition of the insertion of the food probe (cycles piloted either by food probe temperature or by time)
- ◆ Single sensor core probe as standard.

CHARACTERISTICS	MODELS		
	BC100A 110001	BC100RA 110003	BC100RDA 110004
Power supply	Electric	Electric	Electric
Productivity per cycle - kg.			
NF Regulations - chilling / freezing	72	72	72
UK Guide lines - chilling / freezing	100	100	100
Cooling unit	Built-In	Remote	Remote
External dimensions - mm			
width	1000	1000	1000
depth/with open doors	1285, 2099	1285, 2099	1285, 2099
height	2471	2232	2232
Internal dimensions - mm			
width	700	700	700
Internal dimensions - mm			
depth	554	554	554
N° and type of door	1	1	1
Door hinges	Right Side	Right Side	Right Side
Trays type	GN 1/1; 600x400	GN 1/1; 600x400	GN 1/1; 600x400
Max load capacity - trays h 65 mm - n°	20	20	20
Compressor power - HP	4.7	minimum 4,7;	
N° defrost in 24 hrs.	4/20'	4/20'	4/20'
Refrigerant type	R404a;	R404a;	R404a;
Refrigeration power - W	7265	16370	16370
Refrigerant power			
at evaporation temperature - °C	-10	-5	-5
Power - kW			
installed-electric	7.47	0.88	0.88
Noise level - dBA	68	65	65
Net weight - kg.	300	180	180
Power supply - V, phases, Hz	400 V, 3N, 50	400 V, 3N, 50	400 V, 3N, 50
Refrigeration unit	Built in	Remote	Remote
Delivered disassembled			●
INCLUDED ACCESSORIES			
1 SINGLE SENSOR PROBE CHILLER+C/FREEZER	1	1	1

- ◆ The control unit provides several operating settings: time/core temperature according to NF and UK regulations, time/air temperature/probe personalised according to national regulations, sterilizing cycle: UV lamps built-in (on request), 3 single sensor or 3-sensor temperature probes (as accessory), ideal for meats, automatic defrosting and manual defrosting. All parameters are programmable.
- ◆ The control unit provides two large displays to read out: time, core temperature, residual time, alarms, service information.
- ◆ Two customizable cycles for each operating modes, allowing setting time and air temperature. These two programs (P1-P2) can be converted into ice-cream specialist cycles (shape maintenance and holding).

- ◆ All information related to the different operating models are recorded: date, time, cycle, core temperature, holding temperature, HACCP accordance.
- ◆ An audible alarm starts when the cycle ends or terminates abnormally.
- ◆ Chilling times can vary according to food quantity, density, moisture contents and type of containers.
- ◆ Internal and external finishing in 304 AISI stainless steel and backpanel in galvanized steel.
- ◆ HCFC, CFC and HFC free insulation (Cyclopentane), HCFC and CFC free refrigerant gas (R404a).
- ◆ Developed and produced in ISO 9001 and ISO 14001 certified factory.
- ◆ Inner cell with rounded corners.

- ◆ Door equipped with removable magnetic gasket with hygienic design.
- ◆ Evaporator with antirust protection.
- ◆ Ventilator swinging panel for easy access to the evaporator.
- ◆ Automatic heated door frame.
- ◆ Thermostatic expansion valve to optimize the cooling unit efficiency.
- ◆ Adjustable feet 150 mm high.
- ◆ Stand alone printer as accessory.
- ◆ PC connection as accessory, gate RS 485.
- ◆ No water connections required: Waste water can be plumbed into drain, but can also be collected in an optional waste container.

*NF HYGIENE ALIMENTAIRE
certifying authority: AFAQ AFNOR CERTIFICATION.
Address: 11, Avenue Francis de Pressense - 93571
Saint-Denis La Plaine Cedex - France. Conformity
with regulation NF031. Certified guarantees: fitness
for cleaning, thermal performance.

ACCESSORIES	MODELS		
	BC100A 110001	BC100RA 110003	BC100RDA 110004
1 SINGLE SENSOR PROBE CHILLER+C/FREEZER	880089	880089	880089
2 SINGLE SENSOR PROBES CHILLER+C/FREEZER	880096	880096	880096
3-SENSOR PROBE FOR CHILLER+C/FREEZER	880088	880088	880088
60-MM PITCH ROLL-IN RACK FOR 20X1/1	922203	922203	922203
80MM PITCH ROLL-IN RACK 14X1/1GN	922205	922205	922205
AIR REMOTE UNIT CHILL+C/FREEZER CW 100KG		880031	880031
AIR/WATER REMOTE UNIT F.BC+BCF LW 100KG		880059	880059
BASE FOR 20X1/1 ROLL-IN RACK	922141	922141	922141
KIT 3 SINGLE SENSOR PROBES FOR BC/BCF	880269	880269	880269
KIT HACCP ADVANCED CONNECT. BC/BCF LW+CW	880183	880183	880183
KIT HACCP EKIS	922166	922166	922166
PRINTER FOR HACCP BASIC VERSION	881532	881532	881532
TROLLEY FOR 20X1/1 ROLL-IN RACK	922132	922132	922132
WATER REMOTE UNIT BLAST CHILLER CW 100KG		880034	880034



www.zanussiprofessional.com

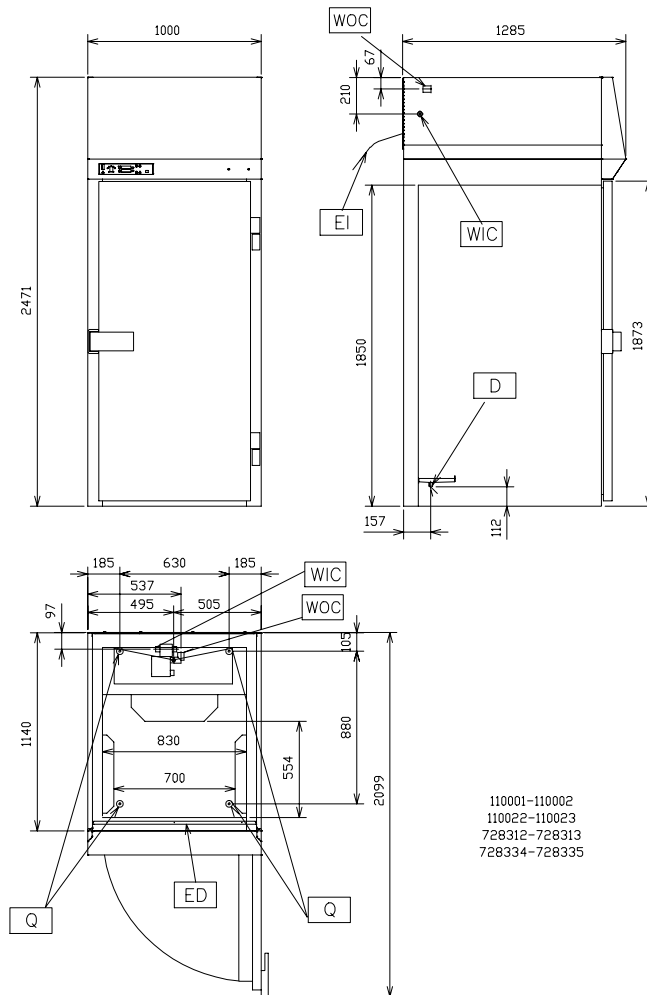

	BC100A 110001
CWI - Cold water inlet	1"
D - Water drain	3/4"
EI - Electrical connection	400 V, 3N, 50
Q - Appliance lifting connection	●
WOC - Cooling water outlet	●



www.zanussiprofessional.com

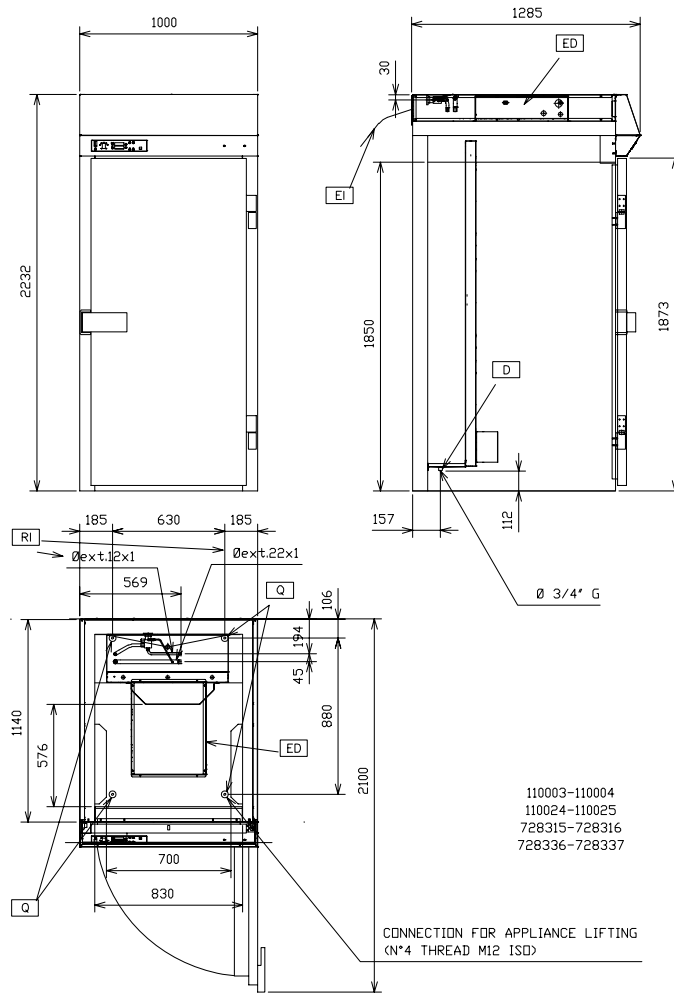

	BC100RA 110003	BC100RDA 110004
D - Water drain	3/4"	3/4"
ED - Remote electrical connection	●	●
EI - Electrical connection	400 V, 3N, 50	400 V, 3N, 50
Q - Appliance lifting connection	●	●
RI - Remote refrigeration connection	●	●

