

User Manual

Dual Band Selective Repeater (27dBm)



2013 January

Information in this manual is subject to change without notice

Table of Contents

1	Description.....	3
2	Technical Specifications	4
3	System Diagram.....	5
4	Product Features	6
5	Applications Example.....	6
5.1	Minimum Signal Levels	6
5.2	Custom Applications.....	7
5.3	Isolation and Separation	8
6	Production Operation.....	8
6.1	Notices	8
6.2	Installation	9
6.3	Commissioning.....	9

NOTICE:

SWITCH AC POWER OFF BEFORE DONOR AND
SERVICE ANTENNA CONNECTS TO REPEATER.

1 Description

The dual band selective repeater (**PODRP27**) is a bi-directional amplifier used to enhance signals between a mobile and a base station. This repeater type is used for digital telecommunication system:



- 1) -It picks up the strongest signal from BTS via the Donor Antenna,
- 2) -Linearly amplifies the signal and then retransmits it via the Indoor Signal Distribution System to the weak/blind coverage area.
- 3) -And the mobile signal is also amplified and retransmitted to the BTS via the opposite direction.

It is commonly used in the area there are two type of mobile network, such as GSM/CDMA, GSM/DCS, and GSM/UMTS. It will reduce site deployment cost by using one dual band donor antenna, one dual band service antenna, and dual band repeaters in one enclosure.

It is applied to small, medium-size areas such as **corporation office**, **shop mall**, **bus station**, **factory** etc.

This model booster is commonly used in situations where large numbers of frequency carriers are to be repeated or when base station synthesized frequency hopping is used.

This model booster does not separate out specific carriers but amplify and retransmit all signals within a defined frequency band. Inter-modulation distortion caused by band selective repeaters usually means that lower output power per carrier can be realized compared to channel selective repeaters.

2 Technical Specifications

		Band A	Band B
Network(Customized)		GSM/3G	
Frequency (Customized)		824~849MHz 1850~1910MHz	869~894MHZ 1930~990MHZ
Gain	Uplink	65±2dB	65±2dB
	Downlink	70±2dB	70±2dB
Output Power	Uplink	23±2dBm	23±2dBm
	Downlink	27±2dBm	27±2dBm
Gain Adjust Scope		MGC≥30	
Gain Adjust Step		1dB	
Gain Adjust precision		0~10dB/±1dB#10~20dB/±1.5dB#20~31dB/±2dB	
Band Ripple		±4	
ALC Scope		20dB	
Frequency Error		≤±0.05	
I/O Impedance		50Ω/N connector	
VSWR		≤1.5	
Noise figure		≤8	
Spurious Emission		≤-36dBm@9KHz~1GHz/≤-30dBm@1~12.75GHz	
IM3		-40dBc	
Delay		≤0.5μs	
Max Input Power Level(1minute)		-10dBm	
RF Connector		N-Type (Female)	
Temperature Range		Operation: -25°C ~ + 55°C;Storage: -30°C ~ +60°C	
Relative humidity		5~95% RH	
Power consumption		50W	
Power Supply		AC220V	
Power Supply(Customized)		AC/110V±10% 60Hz	
Power Supply Socket(Customized)		Connector Type B	
Dimensions		220×150×70mm	
Weight		2.5kg	
Shipment Dimensions		260×200×80mm	
Shipment Weight		3kg	
Indicator	Power Run	- Green Light on	
	RF Output Power	GRAY @ output power<17 GREEN @ working RED @output power >full output power	

3 System Diagram

The RF link (donor) towards the base station is typically fed from an outdoor antenna while the coverage area is fed by an indoor antenna

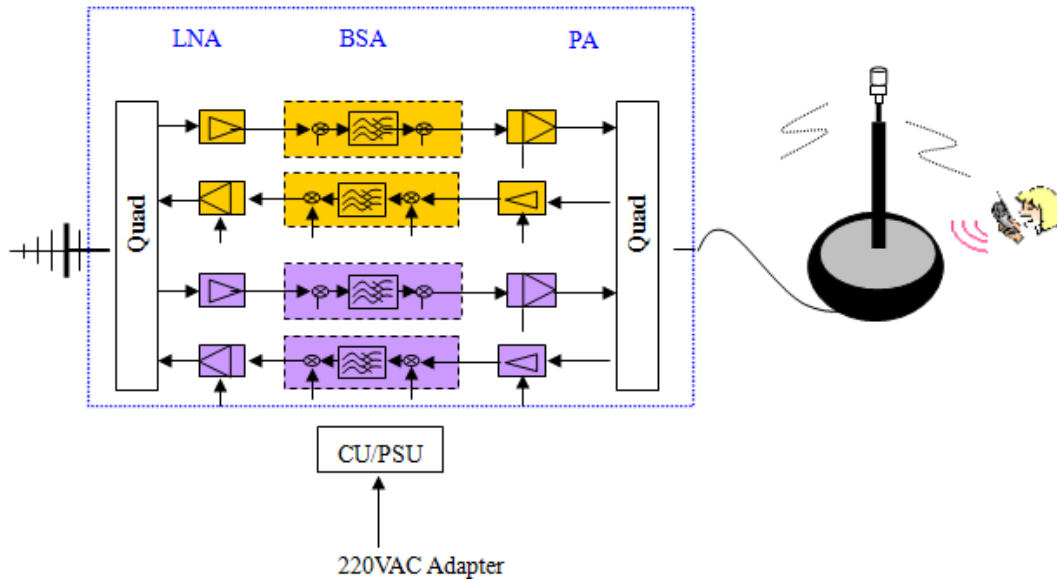

- The signal from the base station is received via the **Dual band Donor antenna**, then forwarded through a **Quad filter (QPX)**, is amplified in a **low noise amplifier (LNA)**, and enters the **band selective amplifier board (BSA)**.
- The first mixer stage on the BSA amplifier board, which is controlled by a synthesizer, converts the received frequency down to the IF frequency. The signal is then filtered by an **IF SAW band-pass filter** and amplified before it is fed to the second mixer stage, controlled by the same synthesizer as the previous one, for converting back to the original frequency.
- The output signal from the mixer is then amplified in the power amplifier, which is controlled by the **CU**(Control Unit board).The output signal passes a **Quad filter (QPX)**, before it is fed to the **Dual band MS antenna** which retransmits the signal at the same frequency to the aim areas.

4 Product Features

- ❑ High **gain>70dB**, High output **power 27dBm**
- ❑ Light weight, small dimensions, easy to install
- ❑ Easy set DL/UL gain via local PIN switch manually for PO20E type, Gain adjustment of uplink and downlink; gain adjust step is 1dB and the adjust scope is 30dB.
- ❑ Smart Automatic Level Control (**ALC**) to reduce interference to BTS
- ❑ **Linear** power amplification to effectively suppress inter-modulation and spurious emission
- ❑ An alarm interface with unique **color LEDs** to indicate power supply and signal level of uplink and downlink
- ❑ Simple installation with external **AC/DC adapter**
- ❑ Dual ports and full duplex design

5 Applications Example

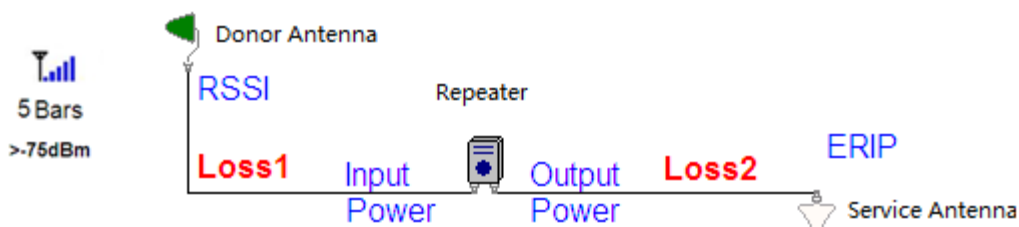

$$\text{RSSI} = \text{Min Reception Signal Level} + \text{Donor Antenna Gain} \quad (1)$$

$$\text{Input Power} = \text{RSSI} - \text{Loss1} \quad (2)$$

$$\text{Output Power} = \text{Input Power} + \text{Repeater Gain} \quad (3)$$

$$\text{ERIP} = \text{Output Power} - \text{Loss2} + \text{Service Antenna Gain} \quad (4)$$

5.1 Minimum Signal Levels

It requires a minimum signal level in the place where install the donor antenna. Failure to provide sufficient input signal will only result in a poor coverage inside the building for this repeater system.

To check signal levels, use the phones in the place where antenna be install (on the roof) and observe the signal bars on the phone. The Donor (outside) antenna should be placed in the location where you get the most signal.



Notices:

- 1) The donor antenna should have line of sight (LOS) with the BTS antenna. If the signal strength is adequate, LOS may in some cases not be necessary.
- 2) Donor antenna gains are typically 9 to 14 dB, and have a horizontal and vertical beam width of less than 30° to correctly select the donor BTS.

5.2 Custom Applications

If building is made of concrete, steel, steel roof, copper roof, brick, aluminum siding, concrete roofing tiles, metal roofing tiles or any other signal stopping material, a repeater is usually the ideal solution for your situation.



Most homes or buildings are easily covered by one repeater systems. Some buildings are larger or have multiple areas inside that need coverage.

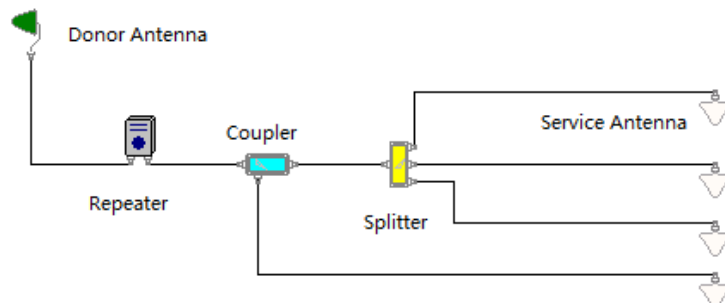

It may need longer cables, more than 2 coverage antennas or other items in order to fully cover your building. We can make (almost) any cable length and can help design a system that fits your application.

5.3 Isolation and Separation

Isolation refers to the proper distance or separation needed to keep the Donor antenna signal pattern and the Coverage antenna signal pattern away from each other.

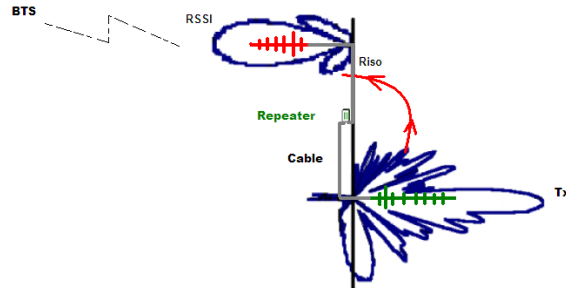

Isolation becomes particularly problematic when Omni-directional antennas are used for both the Donor and the Coverage antennas. Since these antennas transmit in a circle (or more accurately a sphere) it is very easy for these spheres to overlap and thus negate the repeater system.

6 Production Operation

6.1 Notices

Follow below safety items carefully before installation, implementation, maintenance and operation for this product

- ☞ BS and MS port must be connected to donor antenna and service antenna when powers supply on; otherwise the equipment will be damage for long term use.
- ☞ When use repeater for outdoor, the distance between donor antenna and service antenna must be >20metes, otherwise the repeater will be damage because isolation problem for long term use.
- ☞ Donor antenna need to be lighting proof and lighting rod need to be install for donor antenna installation pole outside
- ☞ Check input power, require input power less than maximum input power of repeater, otherwise the repeater cannot work well.
- ☞ Keep clear for label and indicator on surface of repeater to be identified.

6.2 Installation

Step 1: Start by taking phone up to the roof or other location outside to find where the signal is strongest.

Step 2: Temporarily mount the Donor (outside) antenna in that location. It may need to adjust and move the antenna later.

Step 3: Run coaxial cable into the building to a convenient location where you can also get standard 220VAC power for the repeater.

Step 4: Place the repeater in that location and connect the coaxial cable to the Donor Side of the repeater and the donor antenna.

Step 5: Mount coverage (inside) antenna in a productive location. It may need to adjust or move the antenna later.

Step 6: Connect coaxial cable between the coverage antenna and the repeater output port.







Step 7: Power up the system and check for signal inside the building. If needed, tune system by moving and or pointing the Donor and Coverage antennas until get the most signal possible.

Step 8: Secure all antennas and cables, securely mount the repeater and clean up the installation.

6.3 Commissioning



Item	Description	Usage
BTS	Connect to Donor antenna	Receive BTS signal source
MS	Connect to Service antenna	Retransmitted signal to target coverage area

Band A	Left of BTS Side	Set repeater attenuation(Low Band) - Band A is 800M for 800/1900 dual band	
BAND B	Right of BTS Side	Set repeater attenuation(High Band) - Band B is 1900M for 800/1900 dual band	
DC	Power Supply indicator	LEN ON when DC on(9V~12V)	
DL ATT	Band A/B downlink attenuation	Set Downlink attenuation when DL LED @RED light for each band	
UL ATT	Band A/B uplink attenuation	Set Uplink attenuation when UL LED @RED light for each band	
DL LED	Downlink output indicator		output<20dBm (lower input signal)
			output >20dBm and output <27dBm
			output >27dBm (in this case , must set attenuation)
UL LED	Uplink output indicator		output<15dBm (lower input signal)
			output >15dBm and output <23dBm
			output >23dBm (in this case , must set attenuation)

After switch on power supply, please check indication LED as following items.

- You can switch attenuation value by using repeater side switch, If you want to set attenuation 18, you push switch16 and switch 2 on.
- Make sure the repeater full output power LED (Downlink output power) is on when finishes commissioning. (For each band : Set DL PIN switches ON until No RED light (only GREEN))
- And set UL ATT> DL ATT+5dB to balance the downlink and uplink and limited the interference to BTS in uplink direction.

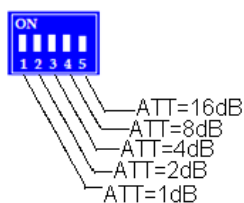

Example:

1 and 2 ON	ATT= 1+2 =3dB
1 and 3 ON	ATT= 1+4 =5dB
1, 4 and 5ON	ATT=1+8+16=25dB
2, 3 and 4 ON	ATT=2+4+8=14dB
1,2,3,4 and 5 ON	ATT=1+2+4+8+16=31dB

- You can change donor antenna direction or installation position to get bigger signal;

- You can set attenuation to add or reduce repeater gain; or you can check cable and connector link status to reduce cable loss and insert loss between repeater and antenna.
- For 850/1900 dual band repeater, the donor antenna direction must be adjustment angle by angle, so the dual band input power require good signal at the same time , then 850 and 1900 can work with maximum coverage area and distance.

