



*LOTOS*<sup>®</sup>

# **LOTOS MIG140**

---

**MIG Welder**



*LOTOS*<sup>®</sup>



*LOTOS*<sup>®</sup>

# TABLE OF CONTENTS

<b>SAFETY</b> .....	4
<b>SPECIFICATIONS</b> .....	9
General Description.....	9
What's Included.....	9
Power Supply Ratings.....	10
Front Control Panel.....	11
Side Components.....	11
Machine Rear.....	12
<b>INSTALLATION</b> .....	13
Machine Setup.....	13
Grounding (Work) Clamp Installation.....	13
Welding Gun Installation.....	14
Welding Drive Roll Installation.....	14
Welding Wire Installation.....	15
Shielding Gas Installation.....	17
<b>OPERATION</b> .....	18
Welding Operations.....	18
Welding Steps.....	18
Welding Process.....	19
Overload Protection.....	19
<b>OTHER ACCESSORIES</b> .....	20

## **Save this Manual**

You will need the manual for safety warnings and precautions, assembly instructions, operating and maintenance procedures, parts list and diagram. Keep your invoice with this manual. Write the invoice number and date of purchase on the inside of the manual. Keep the manual and invoice in a safe and dry place for future use.

## **Operation Manual**

Carefully read the operation manual prior to using, installing and maintaining the electric welding machine for the purpose of preventing damages such as fire, electric shock and etc. from occurring. Please keep the manual for future reference.



# SAFETY WARNINGS AND PRECAUTIONS

---



**PLEASE READ AND UNDERSTAND THE FOLLOWING SAFETY HIGHLIGHTS. BE SURE THAT ALL INSTALLATION, OPERATION, MAINTENANCE AND REPAIR PROCEDURES ARE PERFORMED ONLY BY QUALIFIED INDIVIDUALS. ARC AND TIG WELDING CAN BE HAZARDOUS. PROTECT YOURSELF AND OTHERS FROM POSSIBLE SERIOUS INJURY OR DEATH. KEEP CHILDREN AWAY. PACEMAKER WEARERS SHOULD CONSULT WITH THEIR DOCTOR BEFORE OPERATING.**

---

## **⚠ WARNING**

WHEN USING THE WELDER, ALL BASIC SAFETY PRECAUTIONS SHOULD ALWAYS BE FOLLOWED TO REDUCE THE RISK OF PERSONAL INJURY AND DAMAGE TO EQUIPMENT.

### **READ ALL INSTRUCTIONS BEFORE USING THIS WELDER.**

**Keep work area clean.** Cluttered areas invite injuries.

**Observe work area conditions.** Do not use machines or power tools in damp or wet locations. Do not expose to rain. Keep work area well-lighted. Do not use electrically powered tools in the presence of flammable gases or liquids.

**Keep children away.** Children must never be allowed in the work area. Do not let them handle machines, tools or extension cords.

**Store idle equipment.** When not in use, tools must be stored in a dry location to inhibit rust. Always lock up tools and keep them out of the reach of children.

**Do not force tool.** It will do the job better and safer at the rate for which it was intended. Do not use inappropriate attachments in an attempt to exceed the tool capacity.

**Use the right tool for the job.** Do not attempt to force a small tool or attachment to do the work of a larger industrial tool. There are certain applications for which this welder was designed. Do not modify this welder and do not use this welder for any other purposes for which it was not intended.

**Dress properly.** Do not wear loose clothing or jewelry as they can be caught in moving parts. Protective, flame retardant, electrically non-conductive clothing and non-skid footwear are recommended when working. Wear restrictive hair covering to contain long hair.

**Use eye and ear protection.** Always wear ANSI approved, arc shaded, impact safety face shield (welding helmet). Always use a full-face shield when welding. Always wear ANSI approved eyewear under face shield and while in the workplace. Wear a NIOSH approved dust mask or respirator when working around metal, chemical dusts, fumes and mists.

**Do not over reach.** Keep proper footing and balance at all times. Do not reach over or across running machines.

**Maintain tools with care.** Keep tools sharp and clean for better and safer performance. Follow instructions for lubricating and changing accessories. Inspect tool cords periodically and, if damaged, have them repaired by an authorized technician. The handles must be kept clean, dry, and free from oil and grease at all times.

**Disconnect power.** Unplug tool when not in use.

**Remove adjusting keys and wrenches.** Check that keys and adjustment wrenches are removed from the welder and work area before plugging in.

**Avoid starting unintentionally.** Be sure the switch is in the off position when not in use and before plugging in. Do not carry any tool with your finger on the trigger, whether it is plugged in or not.

**Stay alert.** Watch what you are doing. Use common sense. Do not operate any tool when tired.

**Check for damaged parts.** Before using any tool, any part that appears damaged should be carefully checked to determine that it would operate properly and perform its intended function. Check for alignment and binding of moving parts; any broken parts or mounting fixtures; and any other condition that may affect proper operation. Any part that is damaged should be properly repaired or replaced by a qualified technician. Do not use the tool if any switch does not turn on and off properly.

**Guard against electric shock.** Prevent body contact with grounded surfaces such as pipes, radiators, ranges, and refrigerator enclosures.

**Replacement parts and accessories.** When servicing, use only identical replacement parts. Use of any other parts will void warranty. Only use accessories intended for use with this welder. Approved accessories are available from [www.uwelding.com](http://www.uwelding.com).

**Do not operate tool if under the influence of alcohol or drugs.** Read warning labels on prescriptions to determine if your judgment or reflexes are impaired while taking drugs. If there is any doubt, do not operate the welder.

**Maintenance.** For your safety, service and maintenance should be performed regularly by a qualified technician.

**Use proper size and type extension cord.** If an extension cord is required, it must be of the proper size and type to supply the correct current to the welder without heating up. Otherwise, the extension cord could melt and catch fire, or cause electrical damage to the welder. This welder requires use of an extension cord of 20 amps minimum capability up to 30 feet, with a wire size rated at 12 AWG. Longer extension cords require larger size wire. If you are using the welder outdoors, use an extension cord rated for outdoor use, signified by “WA” on the jacket. Performance of this welder may vary depending on condition in local line voltage. Extension cord usage may also affect welder performance.

## **⚠ WARNING**

**The warnings, cautions and instructions discussed in this instruction manual cannot cover all possible conditions and situations that may occur. It must be understood, by the operator, that common sense and caution are factors, which cannot be built into this product, but must be supplied by the operator.**

### **ARC WELDER SAFETY WARNINGS AND PRECAUTIONS**

**Warning: This product, when used for welding and similar applications, produces chemicals to cause cancer and birth defects (or other reproductive harm).**

## ❖ **ELECTRIC SHOCK can be fatal**



- The electrode and work (or ground) circuits are electrically “hot” when the machine is on. Do not touch these “hot” parts with your bare skin or wet clothing. Protective clothing should be hole free, dry and ANSI approved. Wear dry, hole-free gloves to insulate hands.
- Do not permit electrically live parts, cables, or electrodes to contact skin, clothing or gloves.
- This unit draws enough current to cause serious injury and or death.
- Before turning the welder on, check the welder gun to be sure that there are no protruding screw heads and that all insulation is secure.
- Insulate yourself from work and ground using dry insulation. Make certain the insulation is large enough to cover your full area of physical contact with work and ground.
  - Always be sure the work cable makes a good electrical connection with the metal being cut. The connection should be as close as possible to the area being cut.
  - Ground the work metal to be cut to a good electrical (earth) ground.
  - Maintain the welding torch, work clamp, power cable and cutting machine in good, safe operating condition. Replace damaged insulation.
  - Never dip the electrode in water for cooling.
  - When working above floor level, use a safety belt to protect yourself from a fall should you get a shock.

## ❖ **FUMES AND GASES can be dangerous**



- Plasma cutting may produce fumes and gases hazardous to health. Avoid breathing these fumes and gases. When cutting, keep your head out of the fume. Use enough ventilation and/or exhaust at the arc to keep fumes and gases away from the breathing zone. In confined spaces or in some circumstances, outdoors, a respirator may be required. Additional precautions are also required when cutting on galvanized steel.
- Do not cut in locations near chlorinated hydrocarbon vapors coming from degreasing, cleaning or spraying operations. The heat and rays of the arc can react with solvent vapors to form phosgene, a highly toxic gas, and other irritating products.
- Read and understand the manufacturer’s instructions for this equipment and the consumables to be used, including the material safety data sheet (MSDS) and follow your employer’s safety practices. MSDS forms are available from your welding distributor or from the manufacturer.

## ❖ **ELECTRIC AND MAGNETIC FIELDS may be dangerous**



are not known.

- ❖ The EMF field that is generated during arc welding may interfere with various electrical and electronic devices such as cardiac pacemakers.
- ❖ Anyone using such devices should consult with their physician prior to performing any electric welding operations.
- ❖ Exposure to EMF fields while welding may have other health effects, which

## ❖ ARC RAYS can burn



- Avoid eye and body damage. Arc rays and infrared radiation can cause injury to the eyes and burn the skin. Wear ANSI approved eye and body protection. Do not allow viewing by visitors without proper eye and body protection.
- Use a shield with the proper filter and cover plates to protect your eyes from sparks and the rays of the arc when plasma cutting or observing open arc plasma cutting.
- Use suitable clothing made from durable flame-resistant material to protect your skin and that of your helpers from the arc rays.
- Protect other nearby personnel with suitable, non-flammable screening and/or warn them not to watch the arc nor expose themselves to the arc rays or to hot spatter or metal.

## ❖ WELDING SPARKS can cause fire or explosion

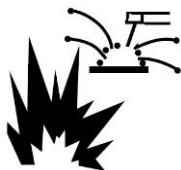

- Remove fire hazards from the cutting area. If this is not possible, cover them to prevent the welding sparks from starting a fire. Remember that welding sparks and hot materials from cutting can easily go through small cracks and openings to adjacent areas. Avoid cutting near hydraulic lines. Have a fire extinguisher readily available. Do not operate the electric arc welder in areas where flammable or explosive vapors are present.
- Where compressed gases are to be used at the job site, special precautions should be used to prevent hazardous situations.
  - Do not heat, cut or weld tanks, drums or containers until the proper steps have been taken to insure that such procedures will not cause flammable or toxic vapors from substances inside. They can cause an explosion even though they have been “cleaned”.
  - Always keep a fire extinguisher nearby while welding.
  - Use welding blankets to protect painted surfaces, dashboards, engines, etc.
  - Please make sure there are no combustible items around your welding area.

## ❖ CYLINDER may explode if damaged



- Use only compressed gas cylinders containing the correct shielding gas for the process used and properly operating regulators designed for the gas and pressure used. All hoses, fittings, etc. should be suitable for the application and maintained in good condition.
- Always keep cylinders in an upright position securely chained to an undercarriage or fixed support.
- Cylinders should be located:
  - Away from areas where they may be struck or subjected to physical damage.
  - A safe distance from arc welding or cutting operations and any other source of heat, sparks, or flame.
- Never allow any electrically “hot” parts to touch a cylinder.
- Keep your head and face away from the cylinder valve outlet when opening the cylinder valve.
- Valve protection caps should always be in place and hand tight except when the cylinder is in use or connected for use.

❖ **ELECTRICALLY POWERED EQUIPMENT can be dangerous**



- Turn off input power using the disconnect switch at the fuse box before working on the equipment.
- Install equipment in accordance with the local codes and the manufacturer's recommendations.
- Ground the equipment in accordance with the manufacturer's recommendations.

❖ **MOVING PARTS can cause injury**



- Keep away from moving parts such as fans.
- Keep all doors, panels, covers, and guards closed and securely in place.

.....  
Please read this Operation Manual carefully and thoroughly before attempting to operate this machine. Keep this manual handy for quick reference. Pay close attention to the safety instructions provided for your own protection.  
.....



# SPECIFICATIONS

## ❖ GENERAL DESCRIPTION

The LOTOS MIG140 features a 140 amp MIG welder that can weld at industrial quality and performance at a very affordable price. The most versatile and perfect welder for do-it-yourself home users as well as professional users. The LOTOS MIG140 is also spool gun capable for welding aluminum. It can be easily connected to your existing 110V wall outlet and quickly setup within 10 minutes or less. It handles industrial standard 4" or 8" wire spools and incorporates a thermal overload protection system to protect your welder.

- ✓ 140-amp MIG Welder with mask, etc.
- ✓ Operates on 110V, Single phase 60Hz
- ✓ Suitable for welding stainless steel, mild steel, aluminum (with a spool gun), and other metal materials

## ❖ WHAT'S INCLUDED



- Power Supply
- MIG Torch
- Ground Clamp and Cable
- Argon Hose
- Argon Regulator
- Chipping Hammer and Steel Brush
- 2 lb of 0.023" Spool Wire
- Hand-Held Shield,

Wire Brush, Etc.

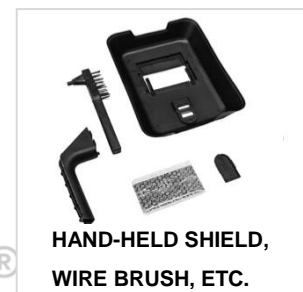
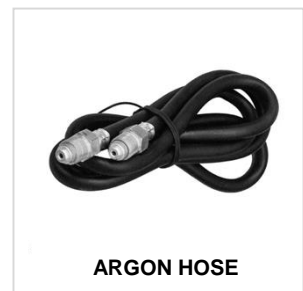
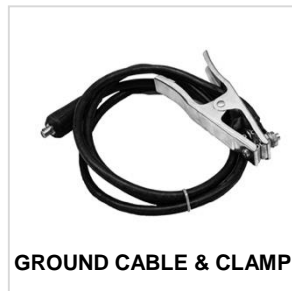

## ❖ POWER SUPPLY RATINGS

MIG140		
General Specifications	Output Power	DC
	Input Voltages	110 V, 1-PH, 50/60 Hz
	Dimensions	16" (408mm) L 9.6" (244mm) W 14.5" (367mm) H
	Weight	54lbs (24.5kg)
	Rated Duty Cycle <sup>1</sup>	20% @ 90A 18V
Welding Specifications	Gas Supply	Steel: clean, dry, oil-free 75% argon and 25% CO
	Recommended gas inlet flow rate / pressure	12 – 14L/min
	Wire Range	.025"-.030" (0.6-0.8mm) solid steel .030"-.035" (0.8-0.9mm) Flux-Cored
Material	Mild Steel	24 Gauge – ¼"
	Stainless Steel	24 Gauge – ¼"
Warranty	New Unit	1-Year Warranty
	Refurbished Unit	60-Day Warranty

<sup>1</sup> Duty Cycle is percentage of 10 minutes that unit can weld at rated load without overheating.

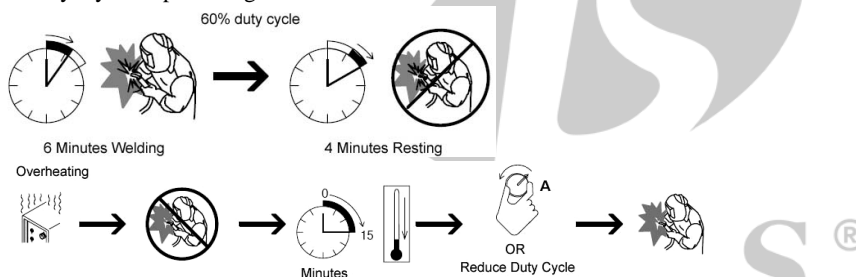

## ❖ FRONT CONTROL PANEL



The unit is connected to the supply even if the Power Switch is in the “OFF” position, and therefore there are electrically live parts inside the power source. Carefully follow the instructions given in this manual.

FRONT CONTROL PANEL	
1	Potentiometer Knob
2	Power Switch
3	Wire Feed rate Adjustment Knob
4	Gun Trigger Lead Connectors
5	Latch

## ❖ SIDE COMPONENTS

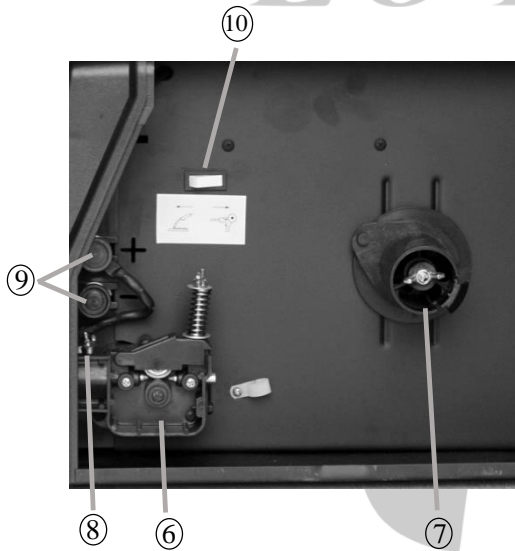

SIDE COMPONENTS	
6	Wire Feed Gearbox
7	Wire Spool Spindle/Shaft
8	Wing Screw (to fasten welding gun)
9	Positive (+) and Negative (-) output terminals
10	Mode Switch (for optional spool gun)

## ❖ MACHINE REAR

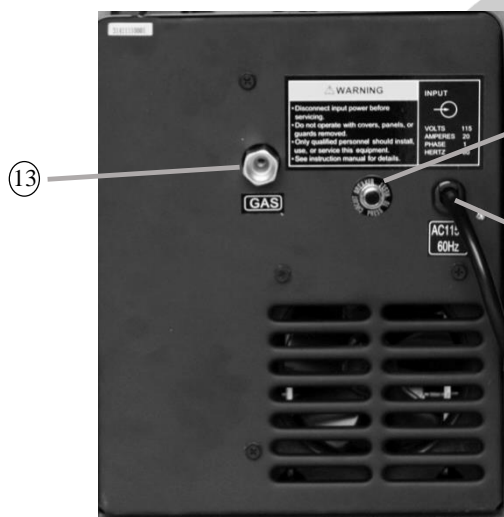

REAR COMPONENTS	
11	Power Cord
12	Reset Overload Protective Device <sup>1</sup>
13	Shielding Gas Inlet Fitting

<sup>1</sup> The protector will cut off the circuit if the welding machine goes over the maximum load, after which the switch must be reset manually.

# INSTALLATION



**PLEASE READ ENTIRE INSTALLATION SECTION BEFORE STARTING INSTALLATION. BE SURE THAT ONLY QUALIFIED PERSONNEL SHOULD PERFORM THIS INSTALLATION.**

## ❖ MACHINE SETUP

### WARNING

#### **ELECTRIC SHOCK can be fatal**

- ◆ Have a qualified electrician install and service this equipment.
- ◆ Turn the input power OFF and unplug the machine from the receptacle before working on this equipment.
- ◆ Allow machine to sit for 5 minutes minimum to allow the power capacitors to discharge before working inside this equipment.
- ◆ Do not touch electrically hot parts.
- ◆ Machine must be plugged into a receptacle that is grounded according to the National Electrical Code and local codes.
- ◆ Do not remove or defeat the purpose of the power cord ground pin.



### ➤ **SELECT SUITABLE LOCATION**

The machine will operate in harsh environments. Even so, it is important that standard measures are followed in order to assure the machine is long lasting and reliable operation.

- The machine must be located where there is open space such that the air circulation in the back and out the front will not be restricted.
- Avoid getting dirt and dust in the machine. Failure to observe these precautions can result in excessive operating temperatures and shutdown by itself.

### ➤ **ENVIRONMENTAL AREA**

Keep the machine dry. Do not place it on wet ground or in puddles. Avoid rainwater. Operating in rain is not allowed.

### ➤ **GROUNDING (WORK) CLAMP INSTALLATION**

(See Figure C-1, Figure C-2)

1. Open the right-side door of the welding machine
2. Insert the lug end of the ground clamp through access hole 2
3. Route the cable of the ground clamp around the wire feed gearbox and connect it to the negative (-) output terminal of the welding machine
4. Tighten the lug plate attached to the end of the wire with wing screw④.

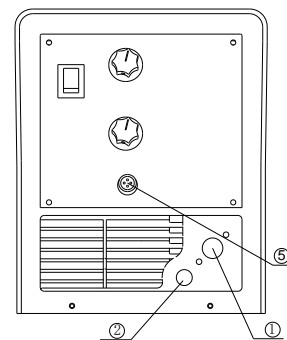

Figure C-1

**NOTE:** This above method of connection is GMAW. When gasless flux-cored wires are used. Connect the cable of the ground clamp to the positive (+) output terminal of the welding machine. The short power cable must be removed from this lug and placed on the negative (-) terminal. (See Reference Table T-1)

## ➤ WELDING GUN INSTALLATION

(See Figure C-1, C-2 and C-3)

There is one spool of .025" (0.6mm) solid welding wire included with the welder. The welding gun comes with a .025" (0.6mm) contact tip installed. If .030-.035" (0.8-0.9mm) wire is to be used, change the contact tip to the appropriate size.

### CONNECT THE WELDING GUN TO THE WELDING MACHINE

1. Power off the welding machine (switch is positioned at "O").
2. Plug the welding gun into the access hole ④ and plug it into the connector block. Also, thread the control wire of the welding gun through the access hole ④ and inset the control wire into the gun trigger connector terminals. ⑤
3. Tighten the wing screw ③ attached to the connector block of the wire feed gearbox.
4. Make sure the Gun changing switch ⑦ is in the correct position MIG for standard welding and Spool Gun if optional gun is installed.

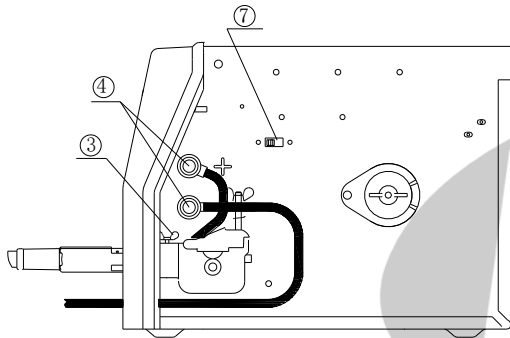

Figure C-2

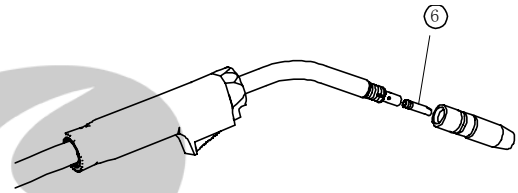

Figure C-3

## ➤ WIRE DRIVE ROLL INSTALLATION

The reversible dual groove wire drive roll attached to MIG140 has two wire grooves; One for .025" (0.6mm) solid welding wire and the other for .030-.035" (0.8-0.9mm) solid or flux-cored welding wire. The factory default installation is .025" (0.6mm).

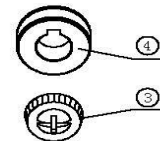
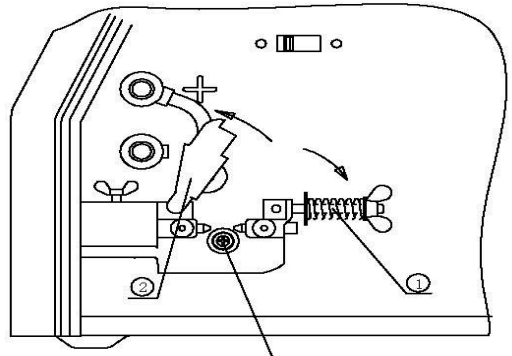

Figure C-4

In the event that .030" (0.8mm) - .035" (0.9mm) welding wires are used, the wire feed roll groove must be changed.

1. Ensure that the MIG140 welding machine is powered off.
2. Unlatch the spring loaded pressure arm and open the idle roll arm. ① and lift up the idle roll arm. ②
3. Loosen the plastic screw ③ that attaches the wire drive roll.
4. Remove the wire drive roll ④ and flip the wire drive roll over so that the .030" (0.8mm) mark faces the user.
5. Reinstall by putting back the wire drive roll and tighten the plastic screw.

## ➤ WELDNG WIRE INSTALLATION

The MIG140 welding machine can use wire spools up to 8" diameter (200mm) and a maximum width under 2" (50mm). If you use the smaller 4" diameter (100mm) wire spools the 2" (50mm) spindle adapter must be removed.

For installation of a 8" (200mm) welding wire spool (See Figure D-1).  
Install the 8" (200mm) welding wire spool on the wire spindle ① ② making sure the wire spool spindle tab engages the hole in the wire spool. (Note: The wire spool will rotate clockwise when wire is de-reeled).

For installation of a 4" diameter (100mm) welding wire spool (See Figure D-2).  
The 2" (50mm) diameter spindle must be removed ②. ④ Remove the wing screw ⑤ and remove the outside plastic wire spool spindle ⑥. A 4" (100mm) diameter spool is mounted directly on a 5/8" (16mm) diameter shaft and held in place with the previously removed hardware. ⑦ (NOTE: The wire spool will rotate clockwise when wire is de-reeled) Also, makes certain the start end of the welding wire, which may protrude through the side of the spool does not contact any metallic case parts

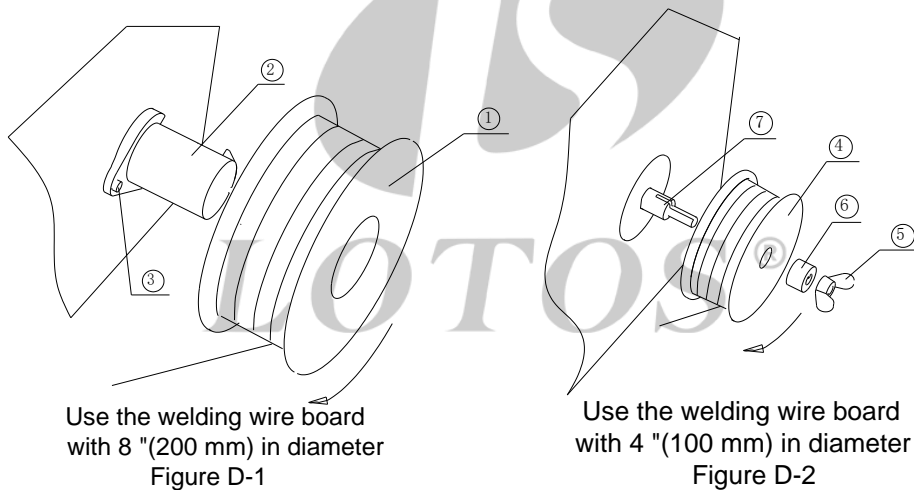

**Thread the Welding Wire through the Wire Feeder by following the instructions shown as below (Figure D-3)**

1. Release the spring-loaded pressure arm ① of the wire feeder and lift up the idle roll arm. ② (Note: the groove size in the feeding position on the drive roll matches the wire size being used, see chapter describing the installation to wire feed roll).
2. Pull out the welding wire ③ from the welding wire spool carefully; To prevent the spool from unwinding, maintain tension on the wire until after Step 5.
3. Cut off the starting end of the welding wire from the wire spool and straighten the lead section of wire from the spool approximately 4" (100mm) long.
4. Thread the welding wire through and into the hole ④ of the inlet guide tube, threading it over the wire drive roll ⑤ and into the hole ⑥ of the outlet guide tube on the gun side. Push the wire into the tailpiece of the gun approximately 6 inches.
5. Place the idle roll arm back to the operating position ② and reset the spring loaded pressure arm ① of the wire feeder.

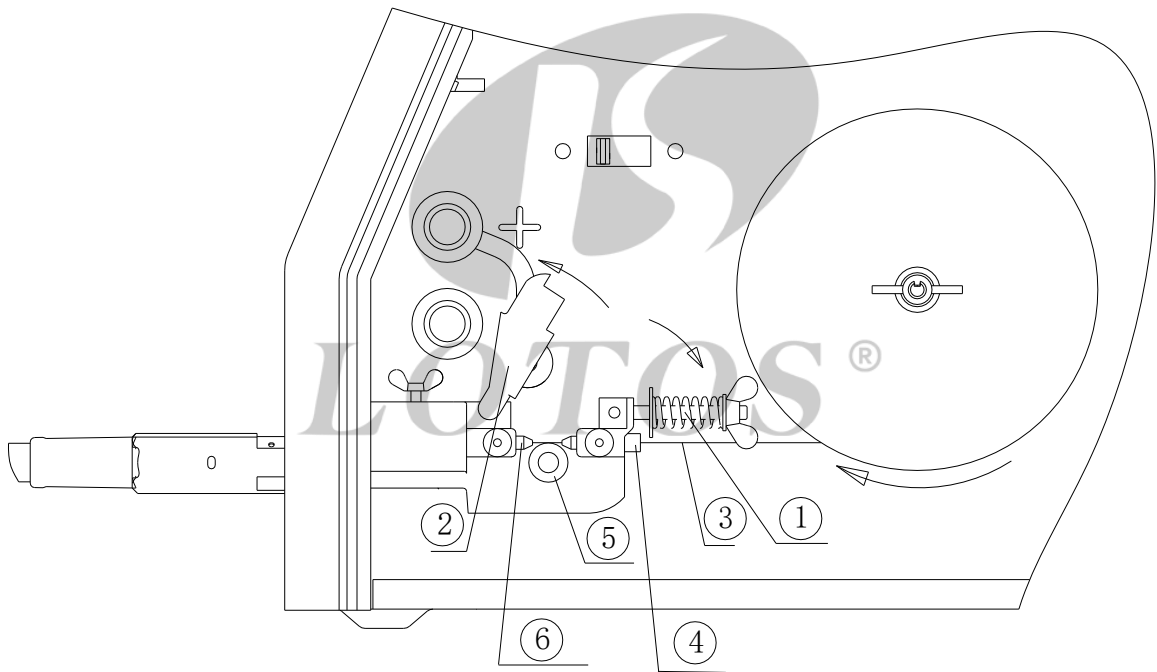
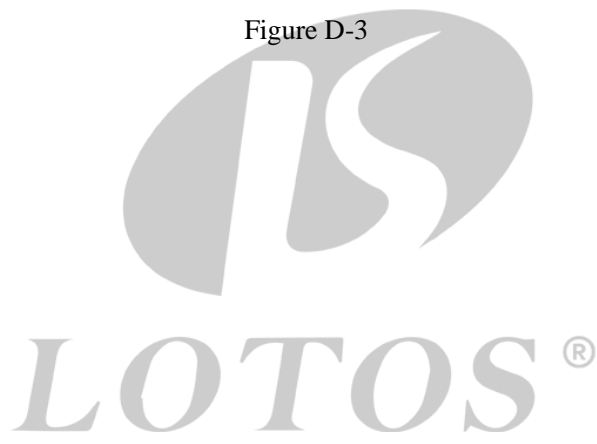

Figure D-3





## ➤ SHIELDING GAS INSTALLATION

Compressed gas cylinder containing mixed gas of, 75% Argon and 25% CO<sub>2</sub> should be used when using the MIG (GMAW - GAS Metal Arc Welding). The flow regulator and supply hose is included with your welder. The compressed gas can be obtained from your local welding supplier.

1. Fix the compressed gas cylinder with a chain, or other method to the wall or other securing device, to prevent the cylinder of falling.
2. After securing, remove cylinder cap if there is one on your cylinder.
3. Install flow regulator (CGA-580) to the supply valve on the cylinder and tighten with wrench.
4. Install one end of the gas supply hose into the outlet of the flow regulator and tighten. Connect the other end of the hose to the gas inlet located at the rear of the MIG140 welding machine (The connector nipple 5/8-18 adapts to CGA-032). Ensure that the hose has no twisting or knotting.
5. Slowly turn on the gas cylinder valve.
6. Depress gun trigger switch and adjust the flow regulator to 25-30 cubic ft per hour (CFH), (12-14 l/min).
7. Shut off the valve of the gas cylinder. Depress gun trigger to release the gas in system. Power off MIG140, when welding process is finished.
8. NOTE: Always keep the valve of the gas cylinder closed when not in use.

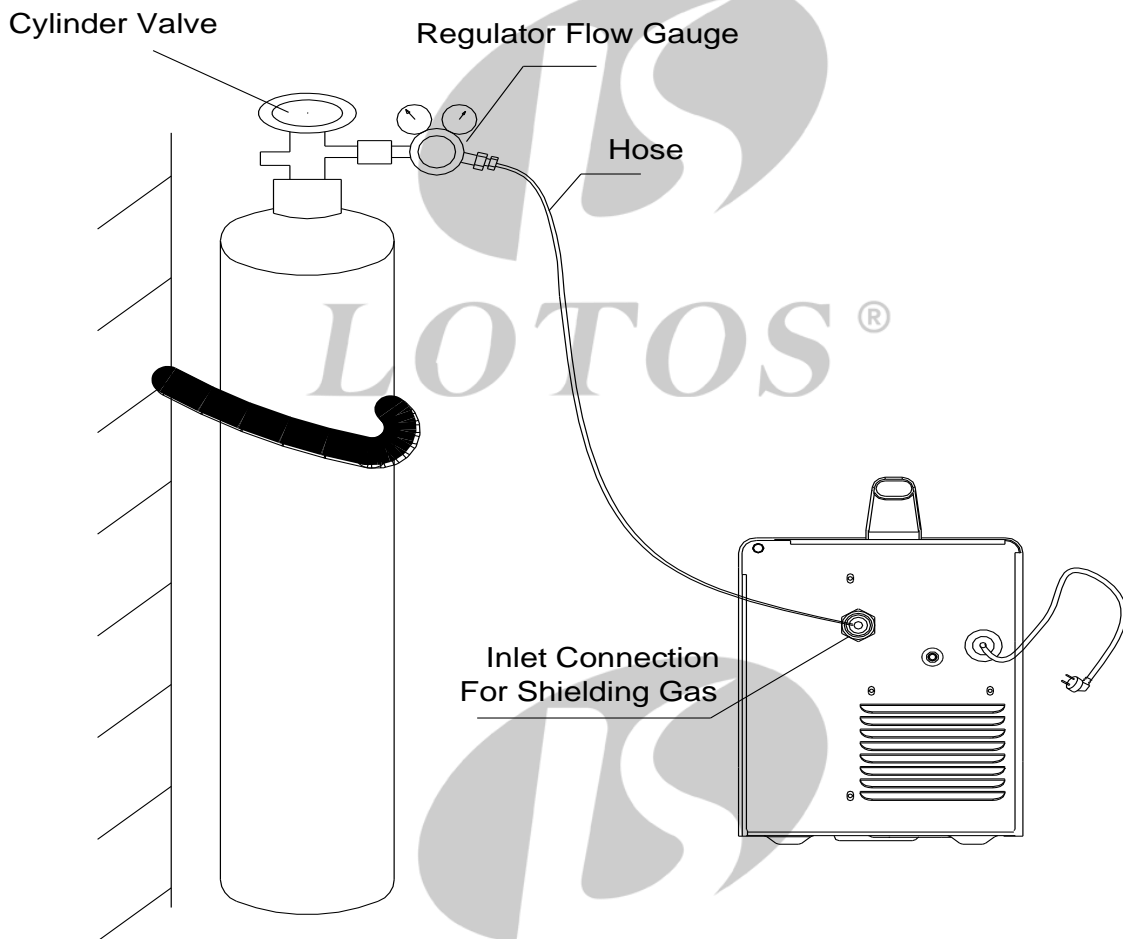

LOTOS®

# OPERATION



**PLEASE READ AND UNDERSTAND THIS ENTIRE SECTION BEFORE OPERATING YOUR MACHINE. ONLY QUALIFIED PERSONNEL SHOULD OPERATE THIS EQUIPMENT. OBSERVE ALL SAFETY INFORMATION THROUGHOUT THIS MANUAL.**

## ❖ WELDING OPERATIONS

### ⚠ WARNING

#### **ELECTRIC SHOCK can be fatal**

- ◆ Have an electrician install and service this equipment.
- ◆ Turn the input power off at the fuse box, disconnect or unplug supply lines and allow machine to sit for five minutes minimum to allow the power capacitors to discharge before working inside this equipment.
- ◆ Do not touch electrically hot parts. Turn the input power OFF and unplug the machine from the receptacle before working on this equipment.



#### **FUMES AND GASES can be dangerous**

- ◆ Keep your head out of fumes.
- ◆ Use ventilation or exhaust to remove fumes from breathing zone.



#### **WELDING SPARKS can cause fires or explosions**

- ◆ Keep flammable material away.
- ◆ Do not weld, cut or gouge on containers that have held combustibles.

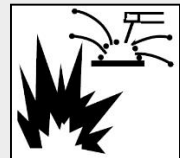

#### **ARC RAYS can burn**

- ◆ Wear eye, ear and body protection.



## ➤ WELDING STEPS

1. Make sure power is off on the MIG140 welding machine
2. Remove nozzle and contact tip
3. Power on MIG140 welding machine
4. Straighten welding gun
5. Hold trigger of the welding gun (depressing trigger will feed the welding wire into the welding gun.) When the welding wire is exposed at the outlet side of the welding gun, release the trigger switch of the welding gun
6. Make sure power is off on the MIG140 welding machine
7. Reinstall the nozzle and contact tip
8. Cut off the welding wire 1/4-1/2" (6-10mm) away from the tip end of the welding gun and get ready for welding

## ➤ **WELDING PROCESS**

1. Please refer to “Welding Control Guide” that is located inside the welding machine door for the output voltage and wire feed rates.
2. Inspect output polarity according to the welding wire being used and ensure whether or not shielding gases are needed.
3. Connect the ground (work) clamp to the piece(s) to be welded; there should be a good connection for the ground (work) clamp to the piece(s).
4. The welding gun should be able to move freely in the area of the piece(s) to be welded.
5. Power on the MIG140 welding machine
6. Pull down welding protective helmet, press the trigger of the welding gun and begin to weld. Keep the contact tip of the welding gun at around 3/8” to 1/2” (10-13mm) away from piece(s) to be welded.
7. Release trigger of the welding gun and the welding is stopped.
8. After welding, turn off the valve of the compressed gas cylinder (if gas is used) and then press trigger of the welding gun to release compressed gas in system. Finally, power off the MIG140 welding machine.

## ❖ **OVERLOAD PROTECTION**

### **Overload protection for power supply to welding**

The MIG140 Welding Machine is equipped with a circuit breaker and a thermostat, which protects the machine from damage if maximum output is exceeded. The circuit breaker button will extend out when tripped. The circuit breaker must be manually reset. Wait for several minutes while the welding machine cools down and reset the circuit breaker button.

## ➤ **THERMAL PROTECTION**

The MIG140 has a rated output duty cycle of 20%. If the duty cycle is exceeded, a thermal protector will shut off the output until the machine cools to a reasonable operating temperature. This is an automatic function and does not require user intervention. The fan continues to run during cooling.

## ➤ **OVERLOAD PROTECTION TO WIRE FEEDER**

The MIG140 model has two automatic circuits to protect the motor of the wire drive.

## OTHER ACCESSORIES

---

The following accessories and consumables can be purchased on [www.uwelding.com](http://www.uwelding.com), or call 408-739-2329 to order.



The LOTOS MIG140 has a factory-installed option to allow you to install and operate a hand held spool gun. This will allow you to do welding of both Aluminum and Steel. To install the spool gun you must first Power Down the welder, remove the standard MIG gun and install the Spool Gun using the same installation process as described on page 9. You must push Switch (7) from MIG to Spool Gun. This will disable the drive system of the welder and enable the Spool Gun's drive system.

### CONSUMABLES



### ACCESSORIES



**AND MORE...  
ON  
[www.uwelding.com](http://www.uwelding.com)**