

No. 4208
8-POINT REMOTE POINT MODULE

INSTALLATION INSTRUCTIONS

GENERAL

The ADEMCO No. 4208 REMOTE POINT MODULE (RPM) is an optional device used with point protection security systems such as some VISTA controls. Each RPM interfaces with and uniquely identifies up to eight protection loops to the control. Although the No. 4208 will not, in any way, expand the number of available protection points in a system, it does afford a more simple installation for companies who homerun their sensors to the control or who desire to group the sensors from an area of the protected premises onto one remote point module.

All eight of the sensor loops are end-of-line resistor supervised, permitting the use of N.O. or N.C. sensors on each loop. All eight loops have normal (400 msec) response to sensor faults. However, two can be selected (as a group) to have fast (10 msec) response. Six of the loops can be used with either mechanical or reed contacts and the remaining two can be used just with reed contacts.

INSTALLATION

The No. 4208 installation procedures include programming, mounting and wiring.

PROGRAMMING

Programming the No. 4208 involves assigning a starting sensor address by setting four positions of a five-position DIP switch. Each setting presets a series of eight sensor loop control addresses (1-8, 9-16, 17-24, etc.). Use only switch positions 2, 3, 4, 5 to assign these numbers. DIP switch position 1 selects fast (OFF) or slow (ON) response for sensor loops 1 and 2.

Important: Each No. 4208 used utilizes eight sequential sensor ID numbers, whether or not all eight are used. Do not assign unused ID numbers to other modules. Refer to the control panel Installation Instructions for the programming information for each point, and to determine the valid range of points for the system.

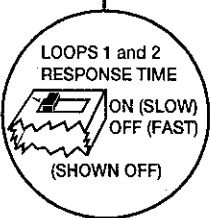
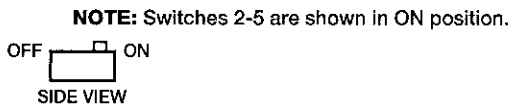
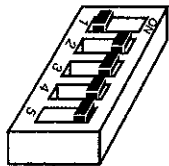

THIS SWITCH SETTING DIP Switch Position				
1	2	3	4	5
on	on	on	on	
on	on	on	OFF	
on	on	OFF	on	
on	on	OFF	OFF	
on	OFF	on	on	
on	OFF	on	OFF	
on	OFF	OFF	on	
on	OFF	OFF	OFF	
OFF	on	on	on	
OFF	on	on	OFF	
OFF	on	OFF	on	
OFF	on	OFF	OFF	
OFF	OFF	on	on	
OFF	OFF	on	OFF	
OFF	OFF	OFF	on	
OFF	OFF	OFF	OFF	

PRESETS THE LOOPS TO THESE SENSOR ADDRESSES							
Loop Number							
1	2	3	4	5	6	7	8
1	2	3	4	5	6	7	8 ←*
9	10	11	12	13	14	15	16 **
17	18	19	20	21	22	23	24
25	26	27	28	29	30	31	32
33	34	35	36	37	38	39	40
41	42	43	44	45	46	47	48
49	50	51	52	53	54	55	56
57	58	59	60	61	62	63	64
65	66	67	68	69	70	71	72
73	74	75	76	77	78	79	80
81	82	83	84	85	86	87	88
89	90	91	92	93	94	95	96
97	98	99	100	101	102	103	104
105	106	107	108	109	110	111	112
113	114	115	116	117	118	119	120
121	122	123	124	125	126	127	N/A

S
e
n
s
o
r

N
u
m
b
e
r

*Do not select 1-8 for VISTA

**If 9-16 is selected for VISTA, Loop 1 (Zone 9) will be inactive.

NOTE: Consult the Control Panel Instructions to determine the valid zone numbers for that control panel.

Diagram 1. DIP Switch Settings

MOUNTING AND WIRING

WARNING: All power should be disconnected before proceeding.

1. **MOUNT** the No. 4208 in a climate controlled location.
 - a) Remove the front cover.
 - b) Draw the mounting holes, using the back cover as a template. Drill the screw holes and install the included mounting screws.

For UL Listed Commercial Burglary Usage:
The No. 4208 must be mounted in a tamper protected enclosure such as the control panel cabinet.

2. **WIRE** the No. 4208 by connecting the polling loop and the protection loops (see Diagram 2.) Maximum, length of protection loop is 1200 feet using 22 gauge twisted pair wire. See the instructions which accompany the control concerning polling loop restrictions.
3. **ATTACH** the wired No. 4208 to its mounting location and tighten the mounting screws.
4. **RECORD** all system information on the cover's label.
5. **REPLACE** the cover.

	TERMINALS	EOL RESISTOR	CURRENT DRAW	LOOP RESPONSE	TYPE OF CONTACTS
LOOP 1	1(+) 2(-)	4,700 ohms 1/4W	1 Milliamp	Fast or Slow*	Reed or Mechanical
LOOP 2	3(+) 4(-)	4,700 ohms 1/4W	1 Milliamp	Fast or Slow*	Reed or Mechanical
LOOP 3	5(+) 6(-)	4,700 ohms 1/4W	1 Milliamp	Slow only	Reed or Mechanical
LOOP 4	7(+) 8(-)	4,700 ohms 1/4W	1 Milliamp	Slow only	Reed or Mechanical
LOOP 5	9(+) 10 (-)	4,700 ohms 1/4W	1 Milliamp	Slow only	Reed or Mechanical
LOOP 6	13(+) 14(-)	4,700 ohms 1/4W	1 Milliamp	Slow only	Reed or Mechanical
LOOP 7	15(+) 16(-)	30,000 ohms 1/2W	100 Microamps	Slow only	Reed only
LOOP 8	17(+) 18(-)	30,000 ohms 1/2W	100 Microamps	Slow only	Reed only

*When Fast/Slow response is selected, the selection affects both Loops 1 & 2 as a pair.

For UL Listed Commercial Fire Usage:
Loops 7 and 8 may not be used. Use N.O. contacts on loops 1-6. Style B supervise these loops using model #EOL47 Fire listed 4.7k EOLR (purchased separately packaged 16 per bag).
For UL Listed Commercial Burglary Usage:
Use N.O. or N.C. contacts on loops 1-8. Supervise using EOLR supplied.

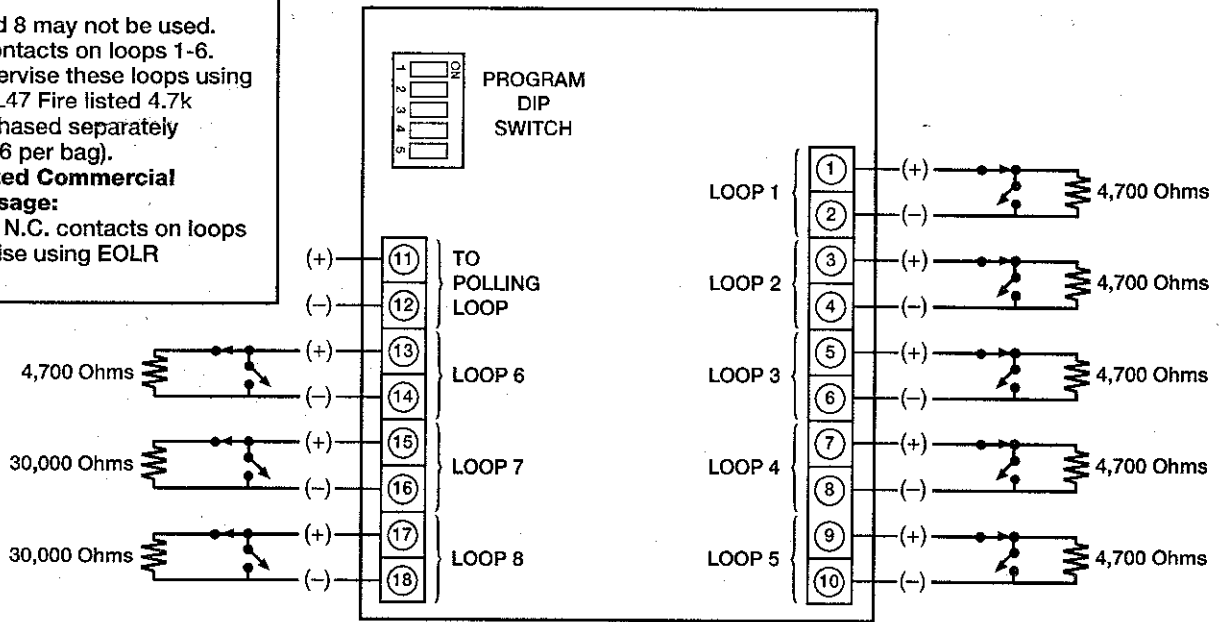

DIAGRAM 2. No. 4208 SUMMARY OF CONNECTIONS

SPECIFICATIONS:

ENVIRONMENTAL:

Temperature: -4° (-20°C) to +158°F (70°C)
Humidity: 90% RH (non-condensing)

POWER CONSUMED:

Voltage Input: 8-11V
Current Drain: 16 mA

DIMENSIONAL:

Width: 3-7/8" (98mm)
Height: 7" (178mm)
Depth: 1-3/8" (35mm)

Sensor Loop Response:

Slow - 400 msec (all loops)
Fast - 10 msec
(option for Loops 1 and 2)

Sensor Loop Current Provided:

Loops 1-6: 1 milliamp
Loops 7, 8: 100 microamps
(sealed reed sensors only)

Sensor Loop Wiring:

Maximum of 1200 feet (365m.) of No. 22 AWG (0.65 mm O.D.) wire

"FEDERAL COMMUNICATIONS COMMISSION (FCC) STATEMENT"

This equipment has been tested to FCC requirements and has been found acceptable for use. The FCC requires the following statement for your information:

This equipment generates and uses radio frequency energy and if not installed and used properly, that is, in strict accordance with the manufacturer's instructions, may cause interference to radio and television reception. It has been type tested and found to comply with the limits for a Class B computing device in accordance with the specifications in Part 15 of FCC Rules, which are designed to provide reasonable protection against such interference in a residential installation. However, there is no guarantee that interference will not occur in a particular installation. If this equipment does cause interference to radio or television reception, which can be determined by turning the equipment off and on, the user is encouraged to try to correct the interference by one or more of the following measures:

- If using an indoor antenna, have a quality outdoor antenna installed.
- Reorient the receiving antenna until interference is reduced or eliminated.
- Move the antenna leads away from any wire runs to the control/communicator.
- Plug the control/communicator into a different outlet so that it and the receiver are on different branch circuits.

If necessary, the user should consult the dealer or an experienced radio/television technician for additional suggestions. The user or installer may find the following booklet prepared by the Federal Communications Commission helpful:

"Interference Handbook"

This booklet is available from the U.S. Government Printing Office, Washington, DC 20402.

The user shall not make any changes or modifications to the equipment unless authorized by the Installation Instructions or User's Manual. Unauthorized changes or modifications could void the user's authority to operate the equipment.

ADEMCO LIMITED WARRANTY

Alarm Device Manufacturing Company, a Division of Pittway Corporation, and its divisions, subsidiaries and affiliates ("Seller"), 165 Eileen Way, Syosset, New York 11791, warrants its products to be in conformance with its own plans and specifications and to be free from defects in materials and workmanship under normal use and service for 18 months from the date stamp control on the product or, for products not having an Ademco date stamp, for 12 months from date of original purchase unless the installation instructions or catalog sets forth a shorter period, in which case the shorter period shall apply. Seller's obligation shall be limited to repairing or replacing, at its option, free of charge for materials or labor, any product which is proved not in compliance with Seller's specifications or proves defective in materials or workmanship under normal use and service. Seller shall have no obligation under this Limited Warranty or otherwise if the product is altered or improperly repaired or serviced by anyone other than Ademco factory service. For warranty service, return product transportation prepaid, to Ademco Factory Service, 165 Eileen Way, Syosset, New York 11791.

THERE ARE NO WARRANTIES, EXPRESS OR IMPLIED, OF MERCHANTABILITY, OR FITNESS FOR A PARTICULAR PURPOSE OR OTHERWISE, WHICH EXTEND BEYOND THE DESCRIPTION ON THE FACE HEREOF. IN NO CASE SHALL SELLER BE LIABLE TO ANYONE FOR ANY CONSEQUENTIAL OR INCIDENTAL DAMAGES FOR BREACH OF THIS OR ANY OTHER WARRANTY, EXPRESS OR IMPLIED, OR UPON ANY OTHER BASIS OF LIABILITY WHATSOEVER, EVEN IF THE LOSS OR DAMAGE IS CAUSED BY THE SELLER'S OWN NEGLIGENCE OR FAULT.

Seller does not represent that the products it sells may not be compromised or circumvented; that the products will prevent any personal injury or property loss by burglary, robbery, fire or otherwise; or that the products will in all cases provide adequate warning or protection. Customer understands that a properly installed and maintained alarm may only reduce the risk of a burglary, robbery, fire or other events occurring without providing an alarm, but it is not insurance or a guarantee that such will not occur or that there will be no personal injury or property loss as a result. CONSEQUENTLY, SELLER SHALL HAVE NO LIABILITY FOR ANY PERSONAL INJURY, PROPERTY DAMAGE OR OTHER LOSS BASED ON A CLAIM THE PRODUCT FAILED TO GIVE WARNING. HOWEVER, IF SELLER IS HELD LIABLE, WHETHER DIRECTLY OR INDIRECTLY, FOR ANY LOSS OR DAMAGE ARISING UNDER THIS LIMITED WARRANTY OR OTHERWISE, REGARDLESS OF CAUSE OR ORIGIN, SELLER'S MAXIMUM LIABILITY SHALL NOT IN ANY CASE EXCEED THE PURCHASE PRICE OF THE PRODUCT, WHICH SHALL BE THE COMPLETE AND EXCLUSIVE REMEDY AGAINST SELLER. This warranty replaces any previous warranties and is the only warranty made by Seller on this product. No increase or alteration, written or verbal, of the obligations of this Limited Warranty is authorized.



ALARM DEVICE MANUFACTURING CO.
A DIVISION OF PITTMAY CORP.
165 EILEEN WAY, SYOSSET, NY 11791
COPYRIGHT © 1994 PITTMAY CORPORATION