

AC Rack

ACR INV222-9.0 LV

USER MANUAL

(The description of single-phase and three-phase application is included)



Notes to this manual

ATTENTION! Read this manual very carefully before installing and commissioning the AC rack. This manual is a part of the delivered AC rack. Familiarity with the contents of this manual is required for installing and operating the AC rack. The rules for prevention of accidents for the specific country and the general safety rules in accordance with IEC 364 must be observed.

The function description in this manual corresponds to the date of publishing. Technical changes and changes in form and content can be made at any time by the manufacturer without notice. There are no obligations to update the manual continually.

The AC rack is manufactured in accordance with applicable DIN and VDE standards such as VDE 0106 (part 100) and VDE 0100 (part 410). The CE marking on the module confirms compliance with EU standards 2006-95-EG (low voltage) and 2004-108-EG (electromagnetic compatibility) if the installation and operation instructions are followed.

Changes and errors excepted.

Supplier:

	ELTEK VALERE DEUTSCHLAND GmbH GB Industrial Schillerstraße 16 D-32052 Herford
	+ 49 (0) 5221 1708-210
FAX	+ 49 (0) 5221 1708-222
Email	Info.industrial@eltekvalere.com
Internet	http://www.eltekvalere.com

©2009. ELTEK VALERE DEUTSCHLAND GmbH. All rights reserved.

AC Rack
ACR INV222-9.0 LV

User Manual
Page 3 (24)

The current revision status of this user manual:

Revision: 3.0

Date: 2010-02-26

Revision	Description of change	Writer	Date
00	First edition.	RTH	2008-04-23
01	Connection tables reworked according to the labelling on the (as from now) serial plexiglass cover.	RTH	2008-06-06
1.0	Section "Optional Equipment" completed, new revision status numbering (X.X) introduced.	RTH	2009-01-21
2.0	Connection table modified (recommended output fuses of the inverter output)	RTH	2009-10-19
2.1	Minor text modifications included.	RTH	2009-12-22
3.0	Three-phase application included.	RTH	2010-02-26

Table of Contents

1. SAFETY INSTRUCTIONS	6
2. ELECTRIC WASTE DISPOSAL	6
3. GENERAL INFORMATION	7
3.1 Block diagram.....	7
3.2 Possible rack configurations	8
3.3 Perspective view/fastening elements	9
3.4 Optional equipment:.....	9
3.5 Cooling/air flow direction.....	10
4. HANDLING	11
4.1 Storage	11
4.2 Commissioning.....	11
4.2.1 Rack assembling	11
4.2.2 Fitting of the modules	11
4.2.3 Communication interface	12
4.2.4 Termination	12
4.2.5 CAN-BUS addresses.....	13
4.2.6 Rear view/electrical connectors	14
4.2.7 Connection tables	14
4.2.8 Schematic diagram (1-phase application)	16
5. THREE-PHASE APPLICATION	17
5.1 Three-phase systems without static transfer switch.....	17
5.2 Three-phase systems with three-phase static transfer switch UNB.....	19
6. MAINTENANCE	21
7. TECHNICAL SPECIFICATIONS	22
7.1 Dimensional drawings	23

Index of Figures

<i>Figure 1. Block diagram</i>	7
<i>Figure 2. AC rack fully equipped with four inverters INV222</i>	9
<i>Figure 3. Sub rack air flow</i>	10
<i>Figure 4. View into the empty rack</i>	11
<i>Figure 5. Rear view of the rack</i>	12
<i>Figure 6. Detail 1: Jumper</i>	12
<i>Figure 7. Detail 2: Hex-switch</i>	12
<i>Figure 8. Rear side connectors</i>	14
<i>Figure 9. Detail: Connector X24</i>	14
<i>Figure 10. Schematic diagram (1-phase application)</i>	16
<i>Figure 11. Example: Three-phase system without STS, three inverters</i>	17
<i>Figure 12. Example: Three-phase system without STS, six inverters</i>	18
<i>Figure 13. Example: Three-phase system with STS, six inverters</i>	20
<i>Figure 14. Rack dimensions</i>	23

1. Safety instructions



Warning!

Because several components of operating electric devices are charged by dangerous voltage, the improper handling of electric devices may be the cause of accidents involving electrocution, injury, or material damages.

- Operation and maintenance of electrical devices must be performed by qualified skilled personnel such as electricians in accordance with EN 50110-1 or IEC 60950.
- Install the unit only in areas with limited access to unskilled personnel.
- Before starting work, the unit must be disconnected from mains. Make sure that the unit is earthed.
- Only spare parts approved by the manufacturer must be used.

2. Electric waste disposal

Separate collection is the precondition to ensure specific treatment and recycling of waste electrical and electronic equipment and is necessary to achieve the chosen level of protection of human health and the environment.

In the case of waste disposal of your discarded equipment we recommend to contact a waste management company.

3. General information

The AC rack is a connection unit ready for integration in system cabinets with a standard 19" frame. The described LV-Rack can be fitted with a maximum of four inverters of the type INV222 (input voltage 48 & 60Vdc) and delivers an output power up to 9.0kVA. After safe connection of the battery and AC distribution, the unit is ready for operation.

To increase the reliability of the power system, a maximum of 10 inverters can be connected in parallel. The rack(s) can be operated without as well as in combination with a static transfer switch. Dependent on the required output power we provide the static transfer switch of the type STS118 (switching capacity= 18kVA) as well as several static transfer switches of the type UNB.

Furthermore the AC rack can be used for **three-phase** applications (see section 5). It is possible to built three-phase systems without as well as with three-phase static transfer switches (three-phase UNB). A maximum of four inverters can be used for each phase.

3.1 Block diagram

ACR INV222-9.0 LV

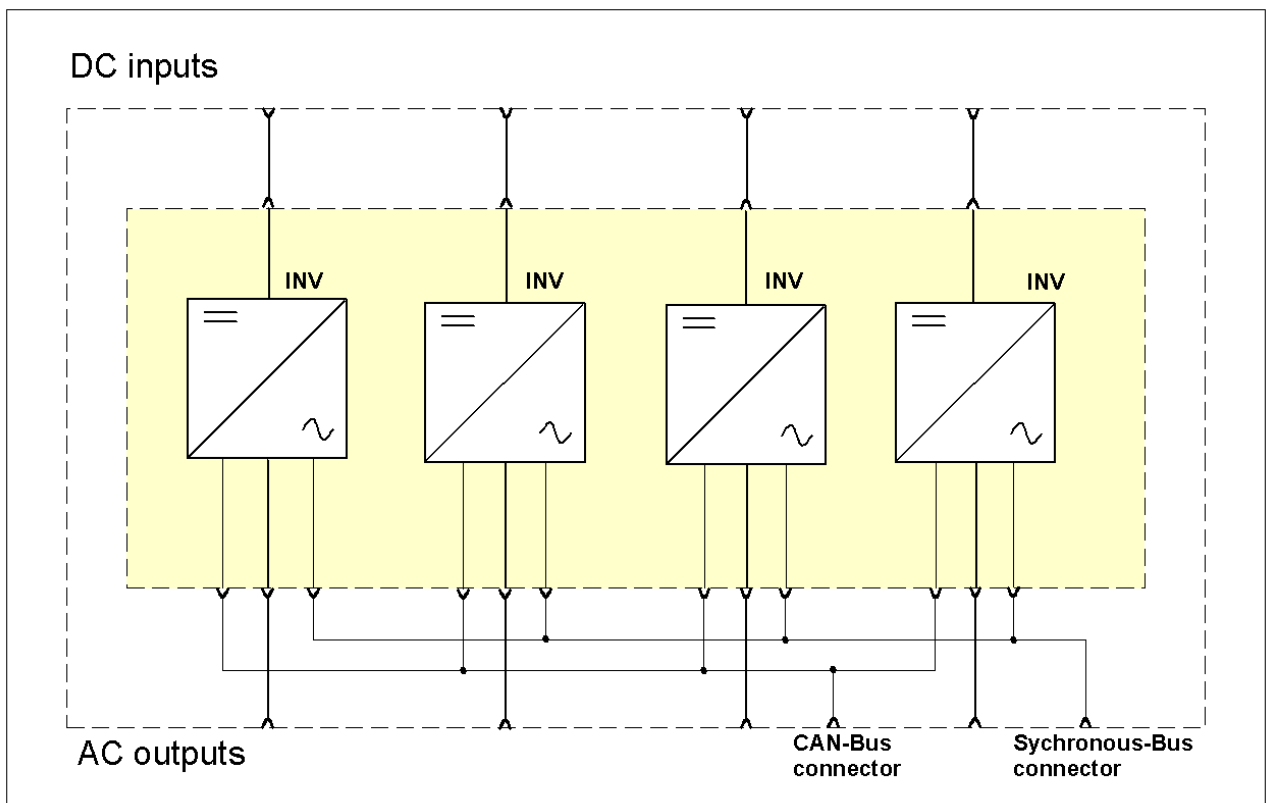

Figure 1. Block diagram

AC Rack

ACR INV222-9.0 LV

User Manual
Page 8 (24)

3.2 Possible rack configurations

Up to four INV222 with DC input voltages according to the table below can be integrated into one rack.

Designation of the rack	Article code	For inverter/ input voltage	Output voltage
ACR INV222-9.0 LV	502-222-405.LV	INV222/48V _{DC}	230V _{AC} , 50Hz
		INV222/60V _{DC}	

Output power (@ cos phi= 0.8) of the rack, equipped with INV222:

Number of installed inverters (INV222)	Output power (without redundancy)	Output power (n + 1)	Output power (n + 2)
1	2250VA	---	---
2	4500VA	2250VA	---
3	6750VA	4500VA	2250VA
4	9000VA	6750VA	4500VA

3.3 Perspective view/fastening elements

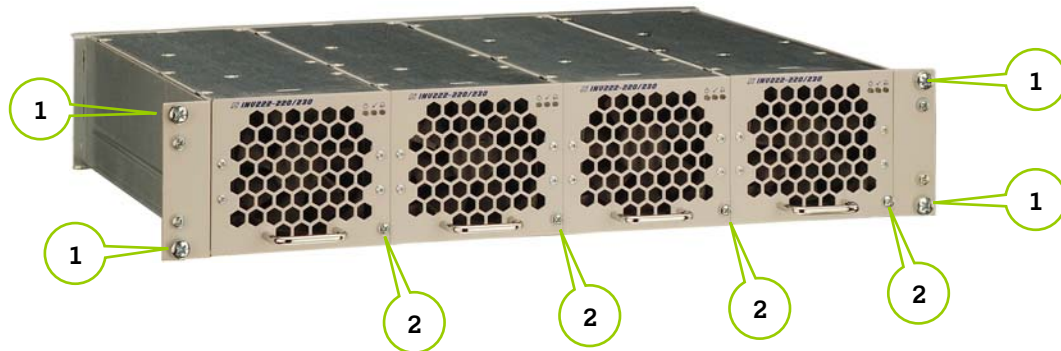

Figure 2. AC rack fully equipped with four inverters INV222

Fastening elements according to figure 2)		Comment
1	There are four screws M6 to fix the sub rack to the frame of the system cabinet	Included in delivery of the sub rack
2	One captive screw per module is used to fix it to the sub rack	Component parts of the modules

3.4 Optional equipment:

Optional equipment according to the following table is available:

Description	Article Code
Cover plate (with handle), necessary to cover empty slots, 1/4 x 19", 2U, colour RAL 7035	881-MEC-BPL.02.21.B
Ribbon cable , 10-pole, length 0.3m; necessary to connect the synchronous busses of two racks which are connected in parallel.	This cable is included in delivery of the sub rack! Spare parts no.: 880-KAB-FBK.03
Ribbon cable , 10-pole, length 0.8m	880-KAB-FBK.08
Synchronous bus adapter ; it is used to connect the wiring of the synchronous busses of the rack(s) to a static transfer switch of type UNB.	880-300-ADP.3.3
CAN-Bus connecting cable , length 0.5m (cables with other lengths are available)	880-KAB-CAN.05

3.5 Cooling/air flow direction

The INV222 modules are fan-cooled. The airflow is from the front to rear side. The fans are monitored and speed controlled dependent on module temperature. To provide sufficient air flow, a minimum space (see item "A" in figure 3.) of 50 mm is required between the air outlet of the modules and the rear cabinet wall as well as an unobstructed supply of air to the front of the modules.

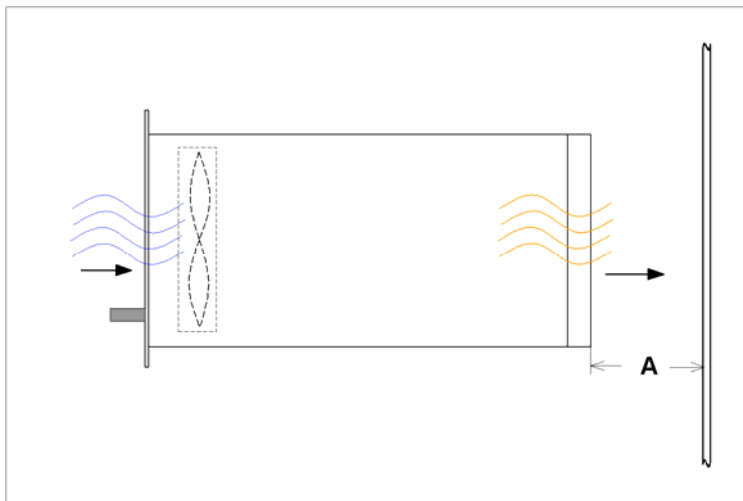

Figure 3. Sub rack air flow

4. Handling

4.1 Storage

AC racks must be stored in a dry, dust free environment with a storage temperature in accordance with the specific technical data ([see Section 7](#)).

4.2 Commissioning

4.2.1 Rack assembling

1. Carefully unpack the unit.
2. Integrate it in your power supply cabinet with 4 screws M6 (**1**) at the front side.

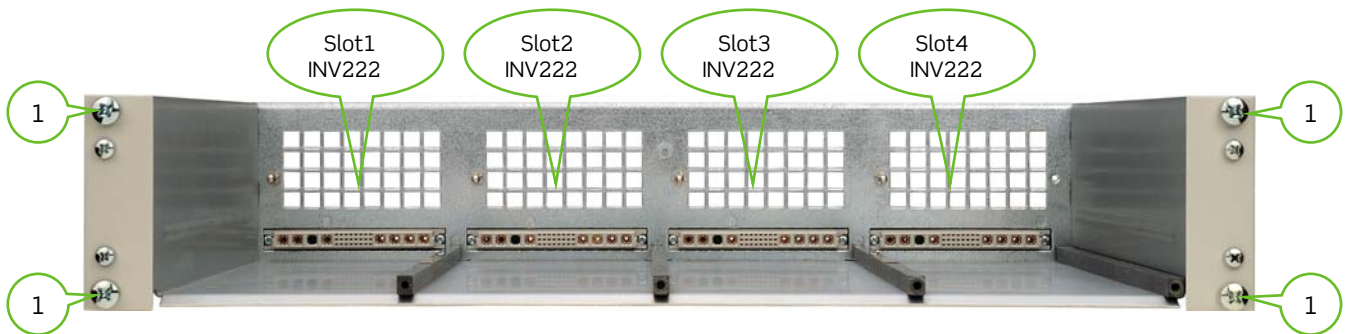

Figure 4. View into the empty rack

4.2.2 Fitting of the modules

1. Fit the modules into the slots of the sub rack.
2. Fill the rack beginning with the left slot.
3. Fix the modules with the captive screws.
4. Not used slots must be covered with cover plates ([see section 3.4 "Optional Equipment"](#)).

4.2.3 Communication interface

The AC rack is equipped with a serial data interface in accordance with the Controller Area Network (CAN) specification.

Several racks and/or modules in a system can be controlled and monitored through the CAN-Bus by a central DC controller unit UPC3.

Two CAN-Bus connectors (X21= CAN 1; X22= CAN 2) are located on the rear of the sub rack (see figure 5.).

Figure 5. Rear view of the rack

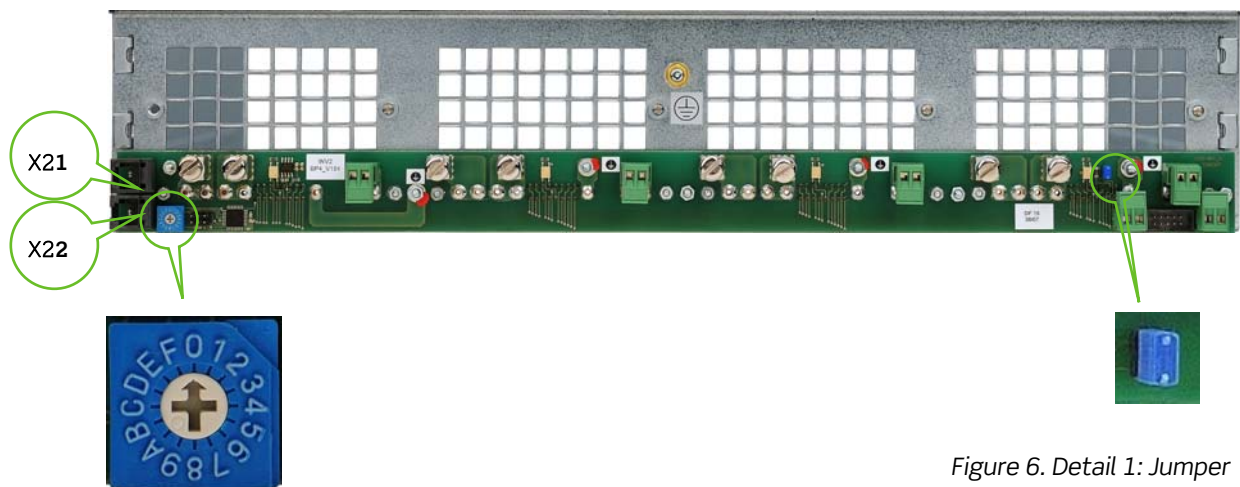

Figure 7. Detail 2: Hex-switch

Figure 6. Detail 1: Jumper

4.2.4 Termination

The CAN-Bus must be terminated at both ends.

- If no other rack and/or module is connected (CAN 2 not used), the CAN-Bus termination resistor must be activated with the plugged jumper at the rear of the backplane of the AC rack (see figure 6.).
- If CAN 2 is connected too, the CAN-Bus termination resistor must be deactivated (the jumper must be removed).
- Not more than two termination resistors should be activated on one bus and these should be located at both ends of the bus.

ATTENTION: Missing terminations or too many terminations within the system can disturb the CAN-Bus communication.

4.2.5 CAN-BUS addresses

All racks (modules) within a system must be addressed for a clear identification through the central DC controller unit. The specific address for each rack must be designated with the CAN address selector (Hex-switch), as shown in [figure 7](#).

Hex-switch position	Rack address
0	1
1	2
2	3
3	4
4	5
5	6
6	7
7	8
8	9
9	10
A	11
B	12
C	13
D	14
E	15
F	16

If only one rack is used within the power supply system, the rack must be addressed with address 1 (Hex-switch position “0” according to the table above).

A second used rack must be addressed with address 2 (Hex-switch position “1”) etc.

The CAN addresses of the installed inverters are automatically designated by the rack.

4.2.6 Rear view/electrical connectors

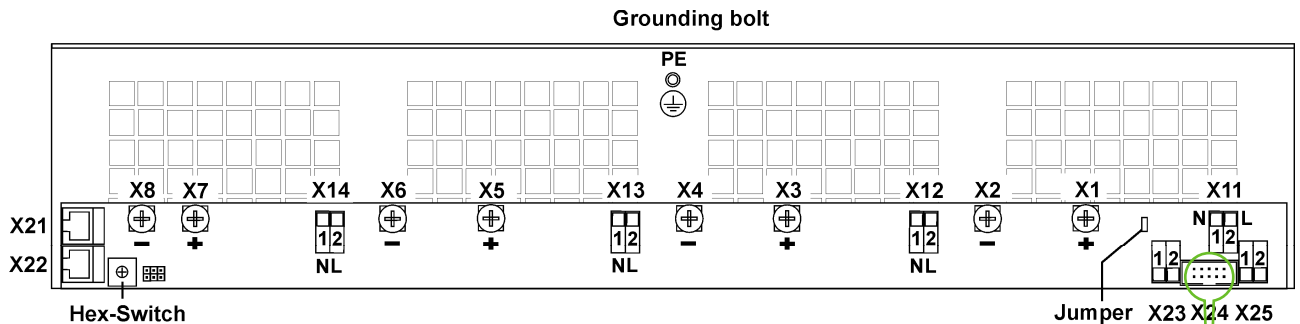

Figure 8. Rear side connectors

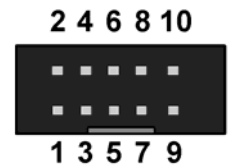

Figure 9. Detail: Connector X24

Connect the terminals according to the connection tables below.

REMARK: The rack itself must be grounded with the cabinet frame (common PE of the system) on the special grounding bolt “PE” (screw thread M5).

4.2.7 Connection tables

Connector assignment of the rear side connectors according to figure 8):

Connector	Function	DC input voltage of the inverters 48 & 60V_{DC}	
		Recommended external fuse	Recommended wire cross section
X1	(+) DC input inverter 1	63A	16mm ²
X2	(-) DC input inverter 1		
X3	(+) DC input inverter 2	63A	16mm ²
X4	(-) DC input inverter 2		
X5	(+) DC input inverter 3	63A	16mm ²
X6	(-) DC input inverter 3		
X7	(+) DC input inverter 4	63A	16mm ²
X8	(-) DC input inverter 4		

AC Rack

ACR INV222-9.0 LV

User Manual
Page 15 (24)

Connector	Function	Recommended external fuse	Recommended wire cross section
X11	AC output of inverter 1		
1	Neutral		1.5 mm ²
2	Line output	10A	1.5 mm ²
X12	AC output of inverter 2		
1	Neutral		1.5 mm ²
2	Line output	10A	1.5 mm ²
X13	AC output of inverter 3		
1	Neutral		1.5 mm ²
2	Line output	10A	1.5 mm ²
X14	AC output of inverter 4		
1	Neutral		1.5 mm ²
2	Line output	10A	1.5 mm ²
X23	Not used		
X24	Synchronous-bus connector (see figure 9)		Ribbon cable, 10-pole, see section „Optional Equipment“.
1 - 4	Not used	No	
5 + 6	SYNC-SIG	No	0.5 mm ²
7 + 8	SYNC-STAT	No	0.5 mm ²
9 + 10	SYNC-GND	No	0.5 mm ²
X25	Inverter “Collective Alarm”		
1	Relay output (COM, NC)	No	0.5 mm ²
2	Relay output (COM, NC)	No	0.5 mm ²

X21	CAN 1 (RJ11, 6-pole)	Cord Set
X22	CAN 2 (RJ11, 6-pole)	Cord Set

4.2.8 Schematic diagram (1-phase application)

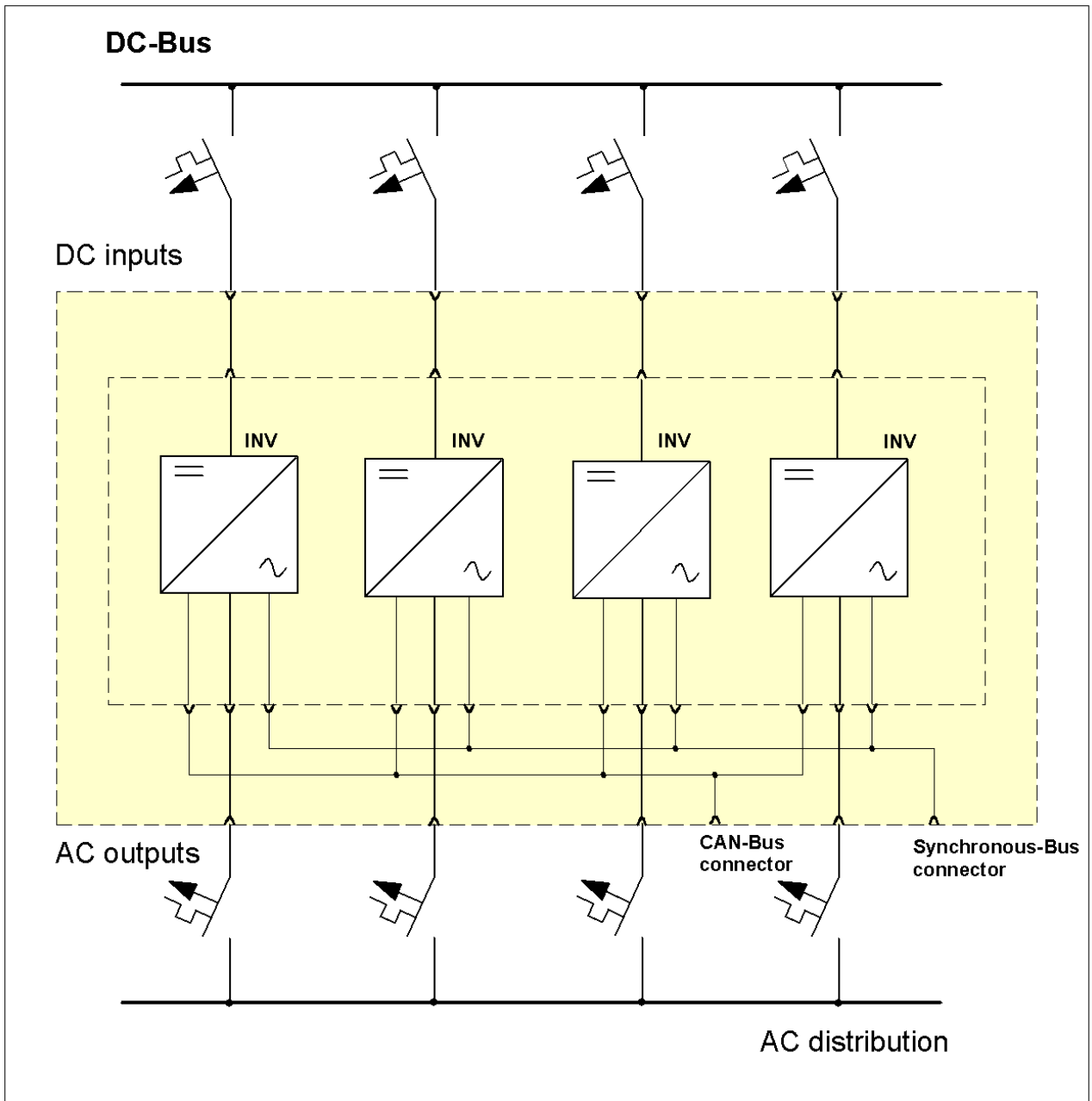

Figure 10. Schematic diagram (1-phase application)



We recommend an individual fuse for each input!
With this fuse you can switch ON/OFF each module individually.

Recommended input and output fuses: See tables above.

5. Three-phase application

ATTENTION! For three-phase application of this rack it is very important to use **special** inverters INV222 for each phase **L1, L2, L3** according to the following table:

	Article Code	
	INV222-48V _{DC}	INV222-60V _{DC}
Phase L1/R	501-022-515.01	501-022-615.01
Phase L2/S	501-022-515.02	501-022-615.02
Phase L3/T	501-022-515.03	501-022-615.03

These INV222 are labeled with a sticker on the front plate down left indicating the phase to which the specific INV222 is programmed, such as “Phase **L1/R**”, “Phase **L2/S**”, “Phase **L3/T**”.

REMARK: Basically a maximum of 12 inverters (four per each phase) can be used at the synchronous bus. That means that a maximum output power of $12 \times 2.25\text{kVA} = 27\text{kVA}$ can be achieved.

5.1 Three-phase systems without static transfer switch

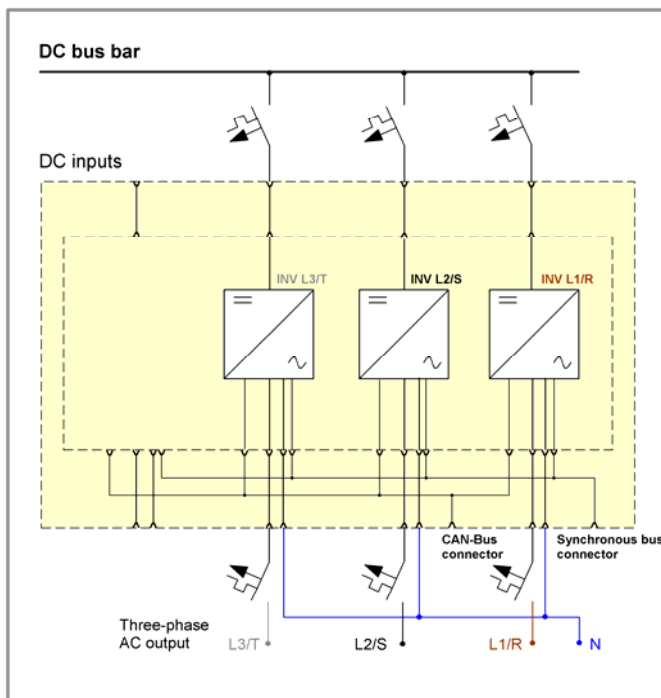
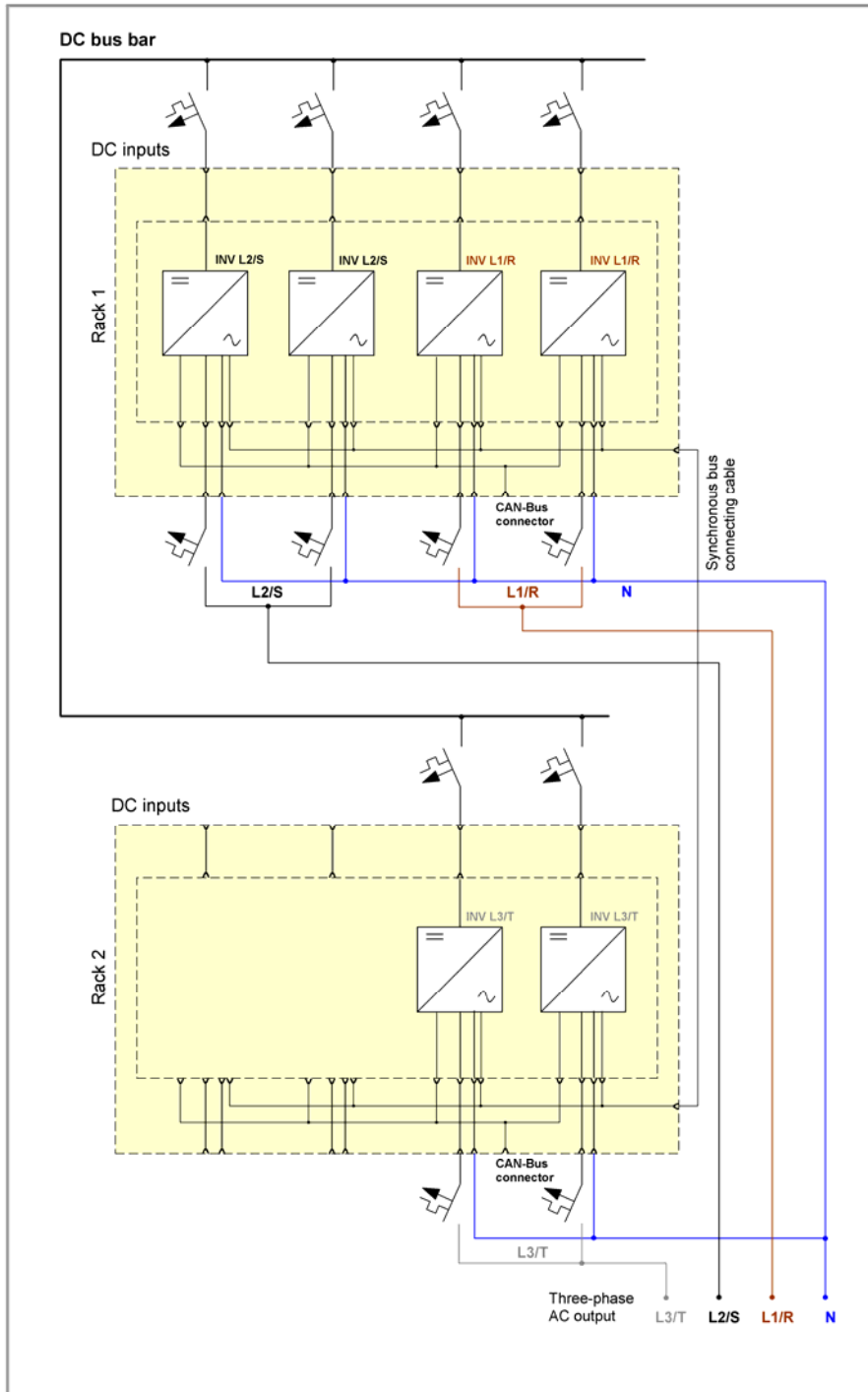

Figure 11.) shows the schematic diagram of a three-phase system without static transfer switch. Three inverters with the phases L1, L2 and L3 are integrated into the rack, slot four is not used.

REMARK: The picture shows the rear view of the rack.

Figure 11. Example: Three-phase system without STS, three inverters



REMARK: The picture shows the rear view of the rack.

Figure 12. Example: Three-phase system without STS, six inverters

As shown in figure 12, this example of a three-phase system consists of six inverters INV222, two per each phase placed side by side, without static transfer switch. The connection of the synchronous bus between both racks is made with a 10-pole ribbon cable included in delivery of the racks.

REMARK: For systems without static transfer switch the placement of the inverters within the rack(s) relating to the phases L1, L2, L3 in principle is at will.

5.2 Three-phase systems with three-phase static transfer switch UNB

For this application three-phase static transfer switches of the type UNB three-phase are suitable. They are available with switching capacity of 3 x 5.0kVA and 3 x 12.5kVA (for details see the table below):

Type	Battery voltage	Article code
UNB 3 x 5.0kVA (for a maximum of two INV222 per each phase)	48VDC	600-050-521.00
	60VDC	600-050-621.00
UNB 3 x 12.5kVA (suitable for the maximum of four INV222 per each phase)	48VDC	600-125-521.00
	60VDC	600-125-621.00

IMPORTANT! Because the three-phase UNB expect the inverters concerning the phases L1, L2, L3 **in strict rotation** it is necessary for three-phase systems with static transfer switch to place the inverters within the rack(s) without gap in the correct order! That means that the slots of the rack(s) must be filled in the following order: Phase L1, phase L2, phase L3, phase L1, phase L2, phase L3 etc.

Example: A three-phase system is to be built using nine inverters: The slots 1, 4, 7 must be filled with inverters of phase L1, the slots 2, 5, 8 must be filled with inverters of phase L2, the slots 3, 6, 9 must be filled with inverters of phase L3.

Consequently it is not possible to fill one rack only with inverters of phase L1, the second rack only with inverters of phase L2 and the third rack only with inverters of phase L3.

Figure 13) on the next page depicts the example of a three-phase system with static bypass switch and six inverters INV222, placed in strict rotation.

REMARK: The picture shows the rear view of the rack.

For the connection of the synchronous bus between UNB and rack(s) the use of a synchronous bus adapter (see section 3.4 "[Optional Equipment](#)") is necessary. The rack is connected to the synchronous bus adapter using the 10-pole ribbon cable (included in delivery of the rack). The static transfer switch UNB is connected to the synchronous bus adapter at the MSTB screw terminals using wires with a recommended wire cross section of 0.5mm².

For the connection of the CAN-Bus of the racks and the UNB it is necessary to use RJ11 cables, 6-pole (see section 3.4 "[Optional Equipment](#)").

AC Rack ACR INV222-9.0 LV

User Manual
Page 20 (24)

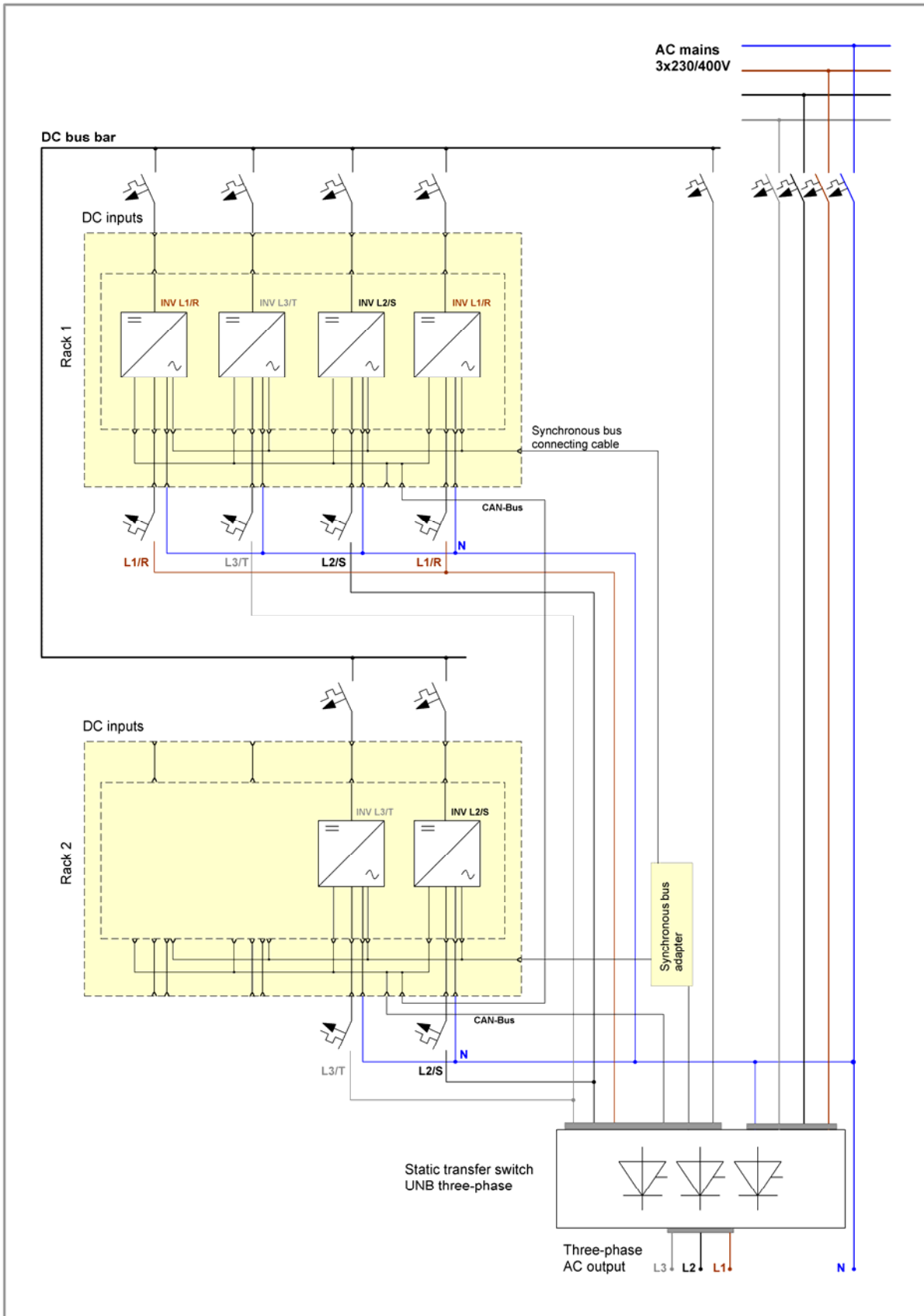

Figure 13. Example: Three-phase system with STS, six inverters

6. Maintenance

In general, the system is maintenance-free.
A yearly inspection with following checks is recommended:

- Correct fan operation (modules)
- Mechanical inspection
- Removal of dust and dirt

Attention! Dust combined with moisture or water may influence or destroy the internal electronic circuits.

Dust inside the unit can be blown out with dry compressed air.
The interval between the checks depends on the ambient conditions of the installed system.

For the exchange of defective fans in the inverter modules, an additional instruction manual is available on request.

7. Technical Specifications

Type designation	ACR INV222-9.0 LV
Article code	502-222-405.LV
Main Data:	
Applicable modules	Designed for the use of 1 up to max. 4 DC/AC inverters of the series INV222 ($V_i = 48; 60V_{DC}$)
Input voltage	48, 60V _{DC} , depending on the used inverters
Internal input fuses	There are no internal fuses, we recommend an individual fuse for each input.
Internal output fuses	There are no internal fuses, we recommend an individual fuse for each output.
Output voltage	230V _{AC}
Output power	2.25 to 9.0kVA @ $\cos \phi = 0,8$
Electric connectors:	
DC input	4 x input (1 for each module), screw thread M5
AC outputs of inverters	4 x (1 for each module); MSTB screw terminals, max. wire cross section 2.5mm ² (for solid and flexible wires)
PE bolt	screw thread M5
Communication interfaces	2 x isolated CAN-Bus connectors (RJ11, 6-pole)
Synchronous-Bus	1 x 10-pole double-row multi-pin connector, spacing 2.54mm
Relais output	Collective Alarm; COM, NC; max. contact load: 60V/0,1A
Environmental:	
Max. installation altitude	≤1500 m
Ambient temperature	operation: -20°C...+55°C; storage: -40°C...+85°C
Audible noise (modules)	≤ 45dB(A) at 1m distance
Mechanical:	
Type of construction	Sub rack, 19", 2U
Cooling	The modules are fan-cooled (front-to-rear airflow), temperature-controlled and monitored
Surfaces	powder coating RAL 7035 (front only), constructive parts: anodized metal
W/H/D	483/88.5/350mm (19", 2U)
Minimum installation depth	400mm plus 25.5mm length of the module handle
Weight	approx. 4.9 kg (excluding INV modules)

Applicable standards:

Mechanical construction	acc. to VDE 0160 edition 5.88 chapter 7.2.2
Protection class	IP20
Climatic conditions	acc. to IEC 721-3-3 class 3K3/3Z1/3B1/3C2/3S2/3M2
RFI suppression / immunity	CE-label, (EN50081-1, EN55011/55022 class „B“, EN50082-2, EN61000-4 part 2/3/4/5)
Compliance to safety standards	acc. to EN60950-1, VDE0100 T410, VDE0110, EN60146

7.1 Dimensional drawings

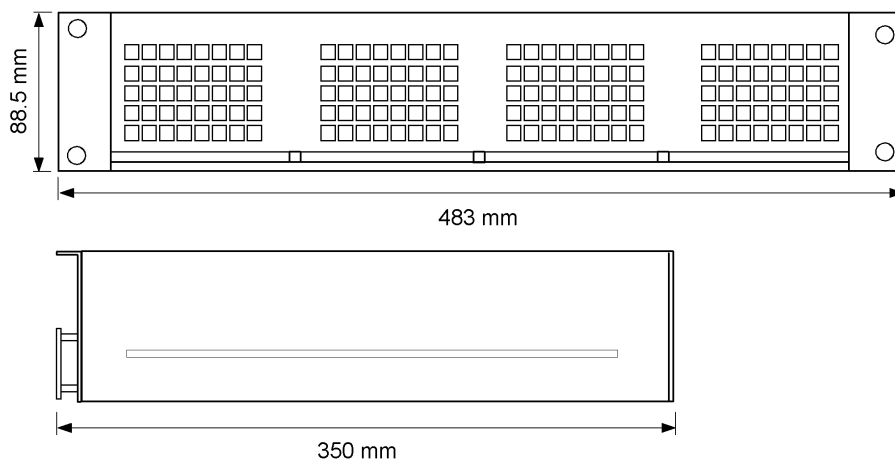

Figure 14. Rack dimensions



Supplier:

	ELTEK VALERE DEUTSCHLAND GmbH GB Industrial Schillerstraße 16 D-32052 Herford
	+ 49 (0) 5221 1708-210
FAX	+ 49 (0) 5221 1708-222
Email	Info.industrial@eltekvalere.com
Internet	http://www.eltekvalere.com