

User Manual

Tripix™ Range

Tripix™ 300

Tripix™ 1200

Tripix™ Wash

Tripix Power™

Tripix Power™ IP66



Martin®

Dimensions

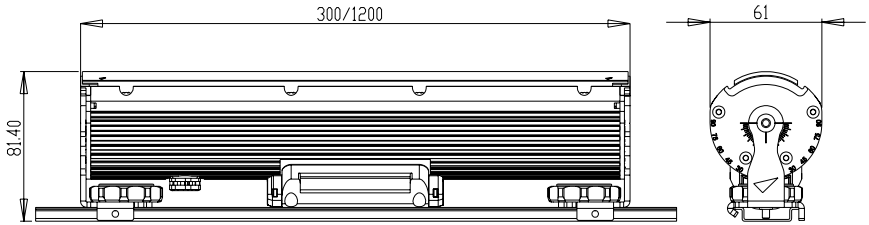
Unit: mm

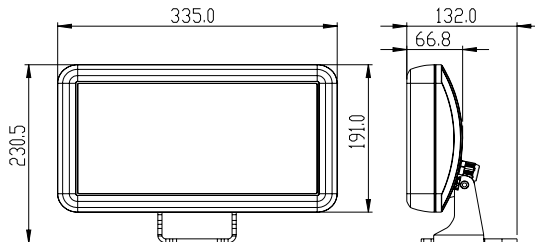

Tripix™ 300 / Tripix™ 1200



Tripix™ Wash

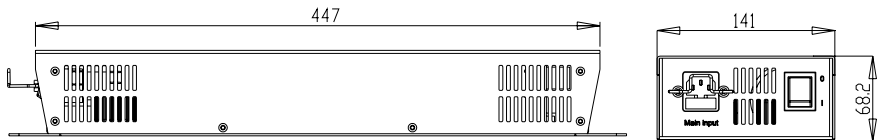

Tripix Power™

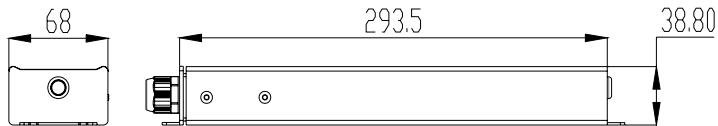

Tripix Power™ IP66

© 2009-2011 Martin Professional™ A/S. Information subject to change without notice. Martin Professional A/S and all affiliated companies disclaim liability for any injury, damage, direct or indirect loss, consequential or economic loss or any other loss occasioned by the use of, inability to use or reliance on the information contained in this manual. The Martin logo, the Martin name and all other trademarks in this document pertaining to services or products by Martin Professional A/S or its affiliates and subsidiaries are trademarks owned or licensed by Martin Professional A/S or its affiliates or subsidiaries.

P/N 35000232, Rev. I

Safety Information

Warning! Read the safety precautions in this section before installing, powering, operating or servicing this product.

The following symbols are used to identify important safety information on the product and in this manual:



DANGER!
Safety hazard. Risk of severe injury or death.



Warning!
Hazardous voltage. Risk of lethal or severe electric shock.



Warning!
LED light emission. Risk of eye injury.



Warning!
Burn hazard. Hot surface. Do not touch



Warning!
Refer to user manual.



Warning! Do not view the light output with optical instruments or any device that may concentrate the beam.

This product is for professional use only. It is not for household use.

This product presents risks of severe injury or death due to fire hazards, electric shock and falls.



Read this manual before installing, powering or servicing the product. Follow the safety precautions listed below and observe all warnings in this manual and printed on the fixture. Install and operate the fixture only as described in this manual and in accordance with local laws and regulations. Refer any operation not described in this manual to a qualified technician.

If you have questions about how to operate the fixture safely, please contact your Martin dealer or call the Martin 24-hour service hotline at +45 70 200 201, or in the USA on 1-888-tech-180.



PROTECTION FROM ELECTRIC SHOCK

- The Tripix Power IP66 does not have a power on/off switch. Make sure that a means of isolating this device from power (an on/off switch or a power plug that can be removed from a power outlet) is easily accessible.
- Shut down power to the entire installation at the main power distribution board and lock out power (by removing the fuse at the distribution board for example) before carrying out any installation or maintenance work.
- Isolate devices from AC power before removing or installing any cover or part and when not in use.
- Connect the Tripix Power and Tripix Power IP66 electrically to ground (earth).
- Use only a source of AC power that complies with local building and electrical codes and has both overload and ground-fault (earth-fault) protection.
- Before using the devices, check that all power distribution equipment and cables are in perfect condition and are rated for the current requirements of all connected devices.
- Isolate all devices from power immediately if any cable, seal, cover or other component is damaged, cracked or deformed. Do not reapply power until repairs have been completed.
- The Tripix Power is for indoor use only. The Tripix Power IP66 can be installed outdoors.
- Refer any service operation not described in this manual to an authorized Martin Service partner.



PROTECTION FROM FIRE AND BURNS

- Do not operate fixtures or the Tripix Power IP66 if the ambient temperature (T_a) exceeds 45°C (113°F). Do not operate the Tripix Power if the T_a exceeds 40°C (104°F).
- The exterior surfaces of the Tripix fixtures, Tripix Power and Tripix Power IP66 can become hot, up to 65°C (149°F), during normal operation. Ensure that accidental physical contact with the devices is impossible.
- Allow all Tripix devices to cool for 5 minutes before servicing.
- Install Tripix devices at least 20 cm (8 in.) away from combustible materials (for example textiles, wood, paper).
- Keep flammable materials well away from Tripix devices.
- Do not modify any Tripix device in any way not described in this manual. Only install genuine Martin parts.



- Use only Martin approved accessories to mask or modify the light beam.
- Do not attempt to bypass fuses. Replace defective fuses with ones of the specified type and rating only.
- Install the Tripix Power indoors in a well-ventilated area only. The Tripix Power IP66 can be installed outdoors. Provide a minimum clearance of 5 cm (2 in.) and ensure unrestricted airflow around all Tripix devices.



PROTECTION FROM INJURY

- Do not look at LEDs with a magnifying glass or any other optical instrument that may concentrate the light output.
- Ensure that all external covers, components and installation fittings are securely fastened.
- Block access below the work area and work from a stable platform whenever installing, servicing or moving the devices.
- Ensure that all supporting structures, surfaces, fasteners and lifting equipment can bear the weight of all the devices they are intended to support plus an adequate safety margin, and that they conform to local building and safety regulations.
- Use a sufficient number of fasteners with sufficient corrosion resistance, dimensions and strength to mount the DIN rail safely. Any nuts used must be self-locking.
- If there is a danger of injury or damage if a Tripix device falls, secure it with an approved secondary attachment such as a safety cable looped around the device or passed through a mounting hole and anchored securely in the mounting surface.



Disposing of this product

Martin™ products are supplied in compliance with Directive 2002/96/EC of the European Parliament and of the Council of the European Union on WEEE (Waste Electrical and Electronic Equipment), as amended by Directive 2003/108/EC, where applicable.

Help preserve the environment! Ensure that this product is recycled at the end of its life. Your supplier can give details of local arrangements for the disposal of Martin products.

Contents

| | |
|--|----|
| Dimensions | 2 |
| Safety Information..... | 3 |
| Introduction | 7 |
| Unpacking | 8 |
| Using for the first time..... | 8 |
| Physical installation | 9 |
| Location and orientation | 9 |
| Mounting..... | 10 |
| AC power..... | 16 |
| Installation setup..... | 19 |
| Tripix system overview | 19 |
| Connecting the Tripix System..... | 24 |
| Fixture configuration | 31 |
| Configuring with MUM | 31 |
| Operation | 40 |
| Service and maintenance | 42 |
| Cleaning | 42 |
| Fixture information and monitoring | 43 |
| Testing..... | 44 |
| Fuse replacement..... | 48 |
| Software installation | 49 |
| Troubleshooting | 51 |
| Specifications | 52 |

Introduction

Thank you for selecting Tripix™, a compact LED-based color-changing lighting product from Martin™. The Tripix is available in Short 300 mm (11.8 inch), Long 1200 mm (47.2 inch) and Wash models. All fixtures are powered by the Tripix Power™ or Tripix Power™ IP66.

The Tripix range features:

- RGB (Red, Green, and Blue) color mixing, with RGB, HSI (hue, saturation, intensity) and HSIC (hue, saturation, intensity, color temperature control) options
- Calibrated and raw (uncalibrated) RGB, calibrated HSI and HSIC
- 82 W LED power from Tripix 1200
- 24 W LED power from Tripix 300
- 72 W LED power from Tripix Wash
- Narrow, medium and wide diffuser filters (narrow fitted as standard)
- Possibility of controlling all fixtures attached to one Tripix Power device as one single pixel
- Possibility of controlling Tripix 1200 and Tripix Wash fixtures as one, two or four separate pixels
- DMX512 control
- 64 pre-programmed stand-alone shows available. Master/slave functionality allows synchronized stand-alone operation
- Possibility of combining a mixture of Tripix 300, 1200 and Wash fixtures on same power and data links
- Clamp mounting system for mounting Tripix 300 and 1200 fixtures on standard 35 mm top-hat DIN rail
- Mounting bracket for Tripix Wash

For the latest firmware updates, documentation, product specifications and other information about this and all Martin Professional™ products, please visit the Martin website at <http://www.martin.com>.

Unpacking

The following items are included with the Tripix fixture:

- Tripix fixture (Tripix 1200 or Tripix 300 or Tripix Wash) with narrow beam angle diffuser installed
- Warning note

The following items are included with the Tripix Power:

- Tripix Power external power supply unit
- Power inserter Y-cable
- DMX termination plug
- Two power cables
- This user manual

The following items are included with the Tripix Power IP66:

- Tripix Power IP66 external power supply unit
- Power inserter Y-cable
- DMX termination plug
- This user manual

Using for the first time

Before applying power to a Tripix installation:

- Carefully review “Safety Information” on page 3.
- Check that the local AC power voltage is within the range listed on the Tripix Power or Tripix Power IP66 serial number label.
- Install the Tripix system as described in this manual.

Physical installation



Warning! Read “Safety Information” on page 3 before installing devices.

The safety and suitability of lifting equipment, installation location, anchoring method, mounting hardware and electrical installation is the responsibility of the installer. All local safety regulations and legal requirements must be observed when installing and connecting the devices. Installation must be carried out by qualified professionals only.

Tripix 300 and 1200 fixtures must be clamped onto a 35 mm DIN top-hat rail that is securely anchored to a suitable flat surface. Tripix Wash fixtures have an integral mounting bracket that must be bolted or screwed to a flat surface. Ensure that the supporting structure can bear the weight of all installed devices plus an adequate safety margin.

Make sure that there will be at least 5 cm (2 in.) of free space and unrestricted airflow around all Tripix devices.

Important! We recommend that you set DMX addresses and configure fixtures before physical installation. See “Fixture Configuration” later in this manual.

Contact your Martin supplier for assistance if you have any questions about how to install this product safely.

Location and orientation

Tripix fixtures have an IP rating of 66 and are suitable for outdoor installation. The Tripix Power has an IP rating of 20 and is for indoor installation only, while the Tripix Power IP66 is suitable for outdoor installation.

Allow 5 cm (2 in.) space and free airflow around the Tripix Power, Tripix Power IP66 and Tripix fixtures. Do not bury or cover any Tripix device.

Install the Tripix Power, Tripix Power IP66 and all Tripix fixtures at least 20 cm (8 in.) away from any combustible materials (wood, paper, etc.) and well away from any flammable materials.

The housings of the Tripix fixtures can reach 65° C (149° F), the Tripix Power housing can reach 55° C (131° F) and the Tripix Power IP66 housing can reach 80° C (176° F). Restrict public access or locate the devices so that they cannot accidentally be touched.

All Tripix devices can be installed in any orientation.

Mounting

Mounting the Tripix 300 and 1200



Warning! Tripix 300/1200 fixtures must be mounted on 35 mm (1.4 inch) top-hat profile DIN rail that is securely anchored to a surface. The installation must conform to local electrical, building, safety and fire regulations. If there is a danger that a device may cause injury or damage if it falls, use a means of secondary attachment such as a safety cable looped around the device and securely anchored to the mounting surface.

Tripix 300 and 1200 fixtures are designed for mounting on standard 35 mm top-hat DIN rail. You can use standard lengths of 35 mm DIN Rail or use Martin Short 35 mm DIN rail supplied in 72 mm (2.8 in.) lengths (P/N 23819560).

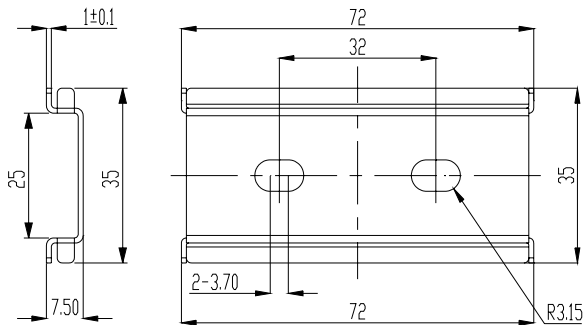

Figure 1: Martin Short 35 mm DIN rail

The special Martin DIN Rail can be ordered from Martin (see “Accessories” in the Specifications section at the back of this manual). Dimensions for the Martin Short DIN rail are given in Figure 1.

Note that you cannot fasten the Tripix fixture mounting clamps directly over screws used to fasten DIN rail to the mounting surface. If a DIN rail mounting screw is in the way of a mounting clamp, move the screw to another slot in the DIN rail.

To mount a Tripix 300 or 1200 fixture on a surface using 35 mm DIN rail:

1. Fasten the DIN rail securely to the mounting surface.
2. See Figure 2. The fixture mounting bracket has a hooked profile on one side (see **A**). Hook this profile over the top of the DIN rail and swing the bracket down. Use a 2.5 mm Allen key to tighten the mounting clamp screw (see **B**).

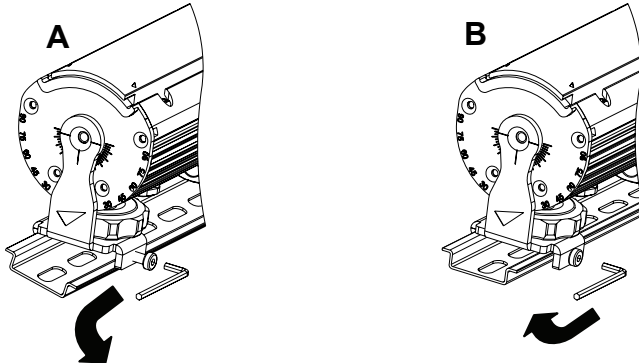

Figure 2: Mounting on DIN rail

3. If there is any danger of the fixture causing injury or damage if it falls, secure it with a secondary attachment such as an approved safety cable attached to a secure anchoring point in the mounting surface.

Mounting the Tripix 300/1200 vertically

The mounting clamp screws will not hold a product securely on the DIN rail if it is installed vertically. You must therefore insert screws in the mounting surface through the DIN rail mounting holes (see arrow in Figure 3) so that the fixture mounting clamps rest against these screws and secure the fixture.

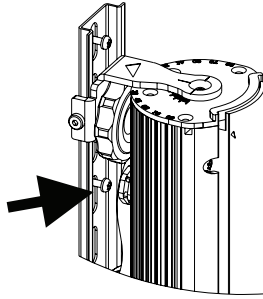

Figure 3: Vertical mounting on DIN rail

Adjusting the Tripix 300/1200 tilt angle

The Tripix 300/1200 can be tilted through 105° (see Figure 4).

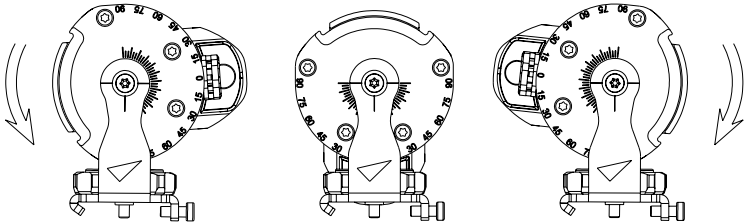

Figure 4: Tilt angle

To adjust the tilt angle:

1. See Figure 5. Turn the locking knob (arrowed) clockwise until it releases the fixture profile.
2. Adjust the fixture to the desired tilt angle.
3. Rotate the locking knob counter-clockwise until it engages in the fixture profile and locks it in position.

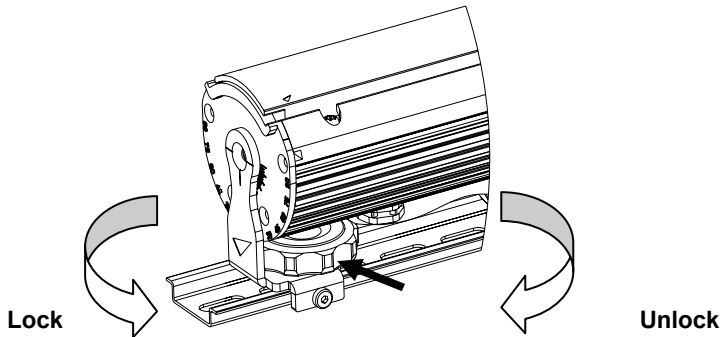

Figure 5: Releasing and tightening the tilt lock

Mounting the Tripix Wash

To mount the fixture on a surface:

1. Mark up the mounting surface for screws or bolts (you can hold the fixture up to the mounting surface temporarily as a guide). Drill suitable holes in the mounting surface and use screw anchors if necessary.
2. See Figure 6. Installing washers under all screw or bolt heads, fasten an M12 bolt or screw with 12 mm (1/2 inch) thread diameter into the mounting surface through the center hole in the base of the bracket, then fasten three M5 bolts or screws with 5 mm (0.2 inch) shaft diameter into the mounting surface through the curved slots in the base of the bracket.

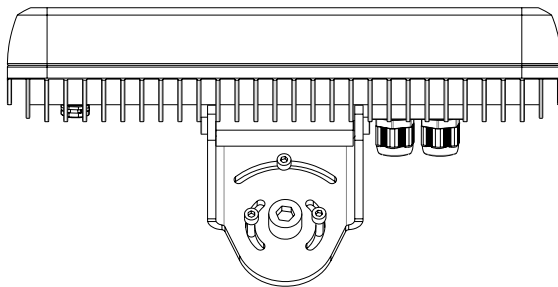

Figure 6: Mounting the Tripix Wash

3. If there is any danger of the fixture causing injury or damage if it falls, secure it with a secondary attachment such as an approved safety cable attached to a secure anchoring point in the mounting surface.

Adjusting the Tripix Wash tilt angle

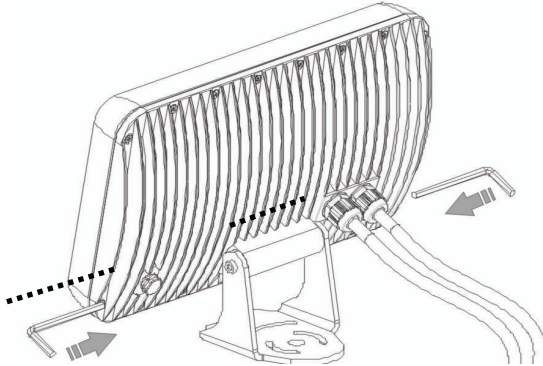

Figure 7: Tripix Wash tilt lock bolts

- The Tripix Wash can be tilted through 163°. To adjust the tilt angle:
1. See Figure 7. Use two 6 mm Allen keys to loosen the tilt lock bolts.
 2. Adjust the fixture to the desired tilt angle (see Figure 8).
 3. Fasten the tilt lock bolts until they lock the fixture in position.

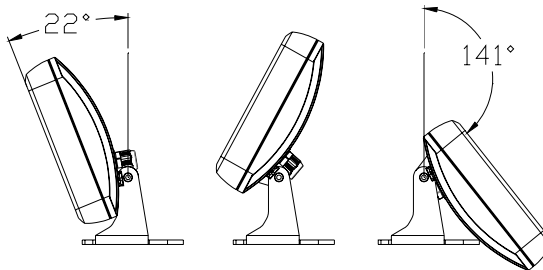

Figure 8: Adjusting Tripix Wash tilt angle

Adjusting the Tripix Wash pan angle

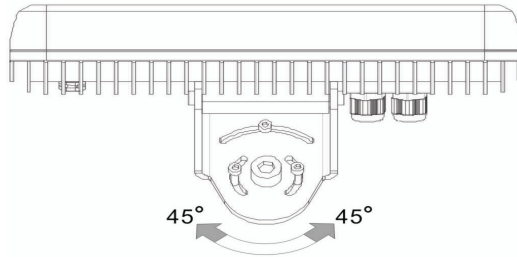

Figure 9: Adjusting Tripix Wash pan angle

The Tripix Wash pan angle can be adjusted through approximately 90°. To adjust the pan angle:

1. See Figure 9. Loosen the four screws or bolts in the base of the bracket.
2. Adjust the fixture to the desired pan angle.
3. Tighten the four screws or bolts in the base of the bracket.

Mounting the Tripix Power and Tripix Power IP66

The Tripix Power must be installed in a dry location only, and the Tripix Power IP66 may be mounted outdoors.

Respect all local safety, fire and building regulations governing the installation of electrical equipment in cavities or plenums. Allow free airflow and at least 5 cm (2 in.) of free space around the devices. Allow sufficient ventilation to ensure that the ambient temperature will not exceed 40° C (104° F) for the Tripix Power and Tripix Power IP66 and 45° C (113° F) for Tripix fixtures.

Both Tripix Power devices must be screwed or bolted securely to a flat surface in a location that is accessible for service using 5 mm shaft diameter screws or M5 bolts through the four mounting holes at the corners of the devices. Use washers under the screw or bolt heads. Use screw anchors in the mounting surface if necessary.

AC power



Warning! Read “Safety Information” on page 3 before installing this product. Lock out power to the entire installation before working on cables and connections or removing any cover.

Warning! Electrical installation must be carried out by qualified professionals only.

Warning! For protection from dangerous electric shock, the Tripix Power and Tripix Power IP66 must be grounded (earthed). The AC power distribution system must be fitted with current overload and ground-fault (earth-fault) circuit breakers as well as a means to isolate the system from power and lock out power during service.

Important! Do not connect the Tripix system to an electrical dimmer system. Doing so can damage the electronics.

If you require help in planning or dimensioning the power distribution system, please contact your Martin supplier for assistance.

The Tripix Power and Tripix Power IP66 must be connected to a single-phase 3-wire (live, neutral, ground/earth) power distribution system at 100-240 VAC nominal, 50/60 Hz. Do not connect to power at any other voltage or frequency.

The Tripix Power IP66 does not have a power on/off switch. Make sure that a means of isolating it from power (an on/off switch or a power plug that can be removed from a power outlet) is easily accessible.

Power input cable



Warning! The electrical equipment and cable used to supply the Tripix system with power must be in perfect condition, be adequately dimensioned for current requirements and respect maximum cable run lengths.

To connect the Tripix Power or Tripix Power IP66 to AC mains power:

- For North America, use only SJTW (or STW), 3-conductor 18 AWG (or 16 AWG) power input cable rated minimum 105° C (221° F), VW-1.
- For the EU, use only power input cable type H05RN-F, 3 x 0.75 mm².

Check the condition of cables carefully. If there is a break or cut at any point in a cable (for example at a connection point), and if this is

exposed to water, moisture can be drawn up the inside of the cable due to the vacuum effect of temperature fluctuations during operation.

Power plug

The Tripix Power and Tripix Power IP66 can be hard-wired to a building's AC mains electrical installation, but if you decide to fit the power cable with a plug that is suitable for your AC mains power outlets, install a grounding-type (earthed) plug following the plug manufacturer's instructions.

Table 1 shows some possible pin identification schemes; if pins are not clearly identified, or if you have any doubts about proper installation, consult a qualified electrician.

| Wire color (US system) | Wire color (EU system) | Conductor | Symbol | Screw (US) |
|------------------------|------------------------|----------------|---|-----------------|
| Black | Brown | Live | L | Yellow or Brass |
| White | Blue | Neutral | N | Silver |
| Green | Yellow/Green | Ground (Earth) |  | Green |

Table 1: Cable color-coding and conductor identification

Tripix Power

The Tripix Power is supplied with a power input cable with an IEC female plug at one end for connection to the Tripix Power's power input socket.

If you replace this cable, use only cable that meets the specifications given under "Power input cable" on the previous page.

Tripix Power IP66

A power input cable that meets the specifications given under "Power input cable" on the previous page must be supplied by the user. The cable must have an external diameter of 5 – 9.5 mm (0.2 – 0.37 in.), otherwise the power cable entry gland will not be effective to IP66.

Installing the Tripix Power IP66 power input cable

1. Unfasten all the screws on the input side cover and lift the cover away from the housing as shown in Figure 10.

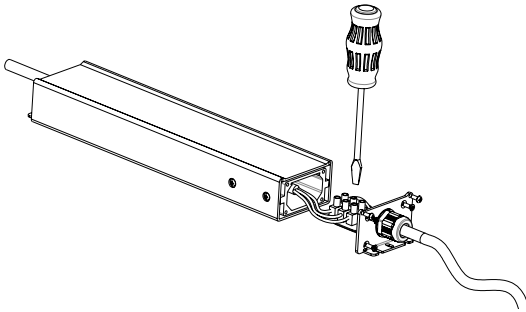

Figure 10: Tripix IP66 power input connections

2. Pass the power input cable through the cable gland.
3. Connect the power cable conductors to the power terminals inside the cover using Table 1 and the markings on the terminals as a guide.
4. Check carefully that the cover seal is correctly positioned, then replace the cover and tighten all the screws to a torque of 1 ± 0.1 Nm
5. Tighten the outer nut on the cable gland to compress the gland and waterproof the cable entry.
6. Prepare the other end of the power input cable for connection to AC mains power, but do not apply power until all installation work is completed.

Installation setup

Tripix system overview



Important! Read this section carefully before making connections. Incorrect configuration of the Tripix system may present a risk of fire or electric shock or permanently damage the Tripix fixture.

Do not connect Martin Tripix and Martin Easyfix™ products together, as they use different data signals.

Figure 11 gives an overview of the basic Tripix system layout. Do not exceed the maximum number of fixtures that can be connected to one Tripix Power or Tripix Power IP66 and do not exceed the maximum combined power and data total cable length given on the next page.

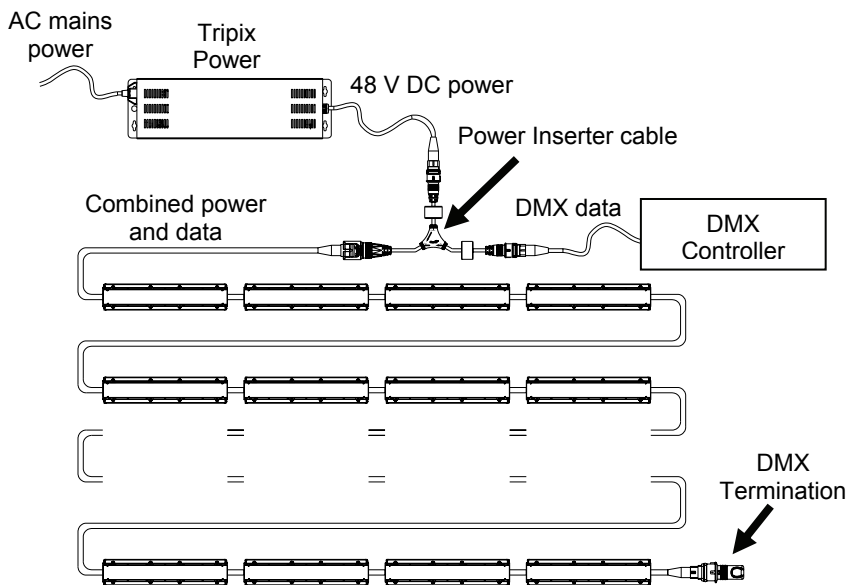

Figure 11: Schematic cable and device layout



Warning! One Tripix Power can safely drive a maximum of:

- 24 Tripix 300s or
- 6 Tripix 1200s or
- 6 Tripix Wash fixtures, or
- any mixture of Tripix fixtures that does not exceed 7.2 meters (23 ft. 7 in.). A Tripix Wash counts as a Tripix 1200.



One Tripix Power IP66 can safely drive a maximum of:

- 12 Tripix 300s or
- 3 Tripix 1200s or
- 3 Tripix Wash fixtures or
- any mixture of Tripix 300 and Tripix 1200 fixtures that does not exceed 3.6 meters (11 ft. 10 in.). A Tripix Wash counts as a Tripix 1200.

Warning! The maximum length of the power link from a Tripix Power or Tripix Power IP66 to the last Tripix fixture on the power link must not exceed the length of the devices' integral cable tails plus 30 m (98 ft.). In other words, you can extend the standard power link by up to 30 m.

Tripix system components

The Tripix system consists of:

- A **Tripix Power** or **Tripix Power IP66** – a power supply that provides fixtures with power at 48 volts DC.
- A **Power Inserter cable** (see Figure 12), P/N: 91611339, a Y-shaped (3-way) cable that is used to connect a Tripix Power device and data from a DMX controller (or PC with USB-DMX Interface) to a chain of Tripix fixtures.

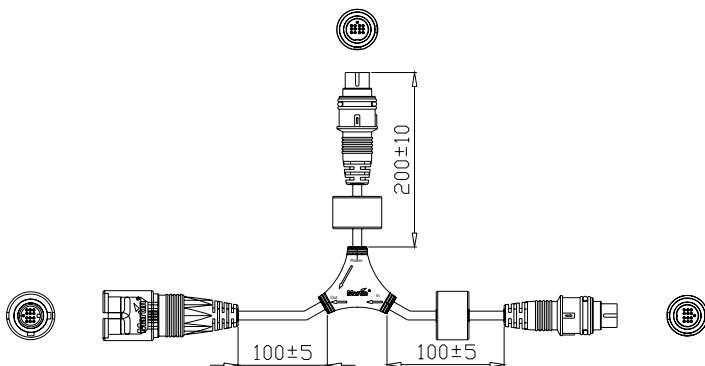

Figur

re 12: Power Inserter cable (dimensions in mm)

The connections to DMX data, power and fixtures are marked on the Power Inserter cable (see Figure 13):

- connect the data signal from a DMX controller or a PC to “In”
- connect the 48 V output from a Tripix Power or Tripix Power IP66 to “Power”
- connect a chain of Tripix fixtures to “Out”.

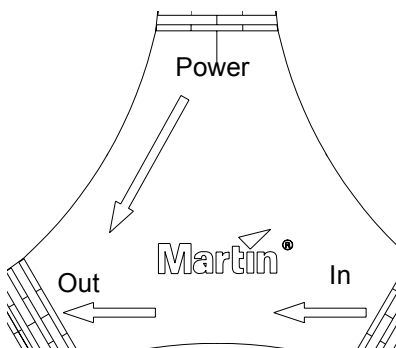
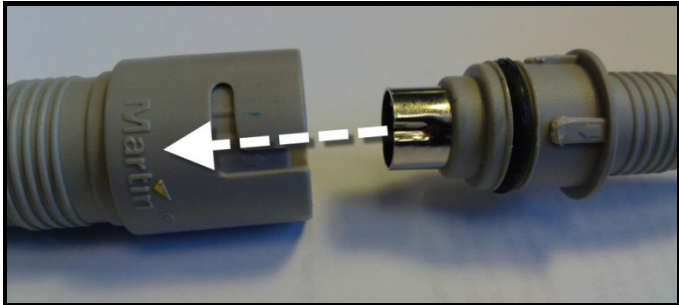

Figure 13: Markings on Power Inserter

- **Tripix fixtures** that have integral cable tails with 13-pin DIN IP66 connectors for combined power and data interconnection. There is only one way to connect the cable tails: the connectors

must be lined up so that the depression in the metal shield of the male connector lines up with the Martin logo on the female connector as shown below or you will damage the pins in the male connector:



- Connectors can be very stiff. Ensure that the male connector is completely inserted creating a tight seal (see below).

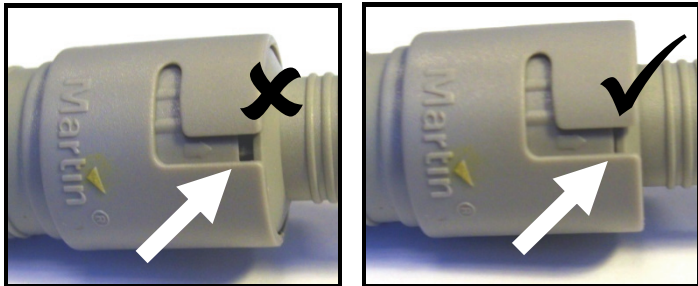

- Once you have engaged the connectors correctly, pass the connector clip rings provided over the cable and screw them onto the connectors until you hear two clicks. This is essential to lock connectors together and ensure a reliable waterproof seal.

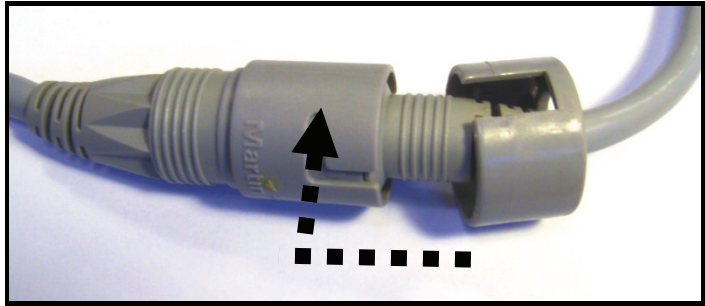

- A **Tripix DMX Termination Plug** (P/N 91611336) that must be inserted in the output cable tail of the last Tripix fixture at the end of the DMX link. This plug is supplied as standard with the Tripix Power or Tripix Power IP66.
- A **Tripix DMX Input Adapter cable** (P/N 91611337) that lets you connect a 3-pin female XLR DMX output to the Power Inserter cable's "In" connector if external DMX control is required or to configure fixtures using the Martin MUM™ PC application and a USB/DMX interface. This 3-pin male XLR to 13-pin female DIN adapter is not supplied as standard and must be ordered separately.
- **Tripix Extension Cables**, available from Martin in various lengths. You only need to use these if Tripix fixtures' integral data/power cable tails are not long enough. Tripix Extension Cables must be ordered separately.
- **Tripix Cable Adapters, IP66, Male + Female** (P/N 91611323). You only need to use these adapters if you need to extend the distance between Tripix devices because the integral cable tails are not long enough, and the Tripix Extension Cables are not suitable. Tripix Cable Adapters must be ordered separately.

Warning! The total length of all extension cables that carry power and that are added to a chain of Tripix fixtures supplied with power by one Tripix power device must not exceed 30 m (98 ft).

- A **Tripix DMX Output Adapter cable** (P/N 91611338) that can be connected to the output cable tail of the last Tripix fixture on a data link. You only need to use this adapter if you need to continue the DMX link to the 3-pin male XLR DMX input of another type of fixture. This 13-pin male DIN to 3-pin female XLR adapter is not supplied as standard and must be ordered separately.

Connecting the Tripix System

Connecting a basic system

Connect a basic Tripix system following the instructions below:

1. Check that the Tripix power device (Tripix Power or Tripix Power IP66) is not connected to AC mains power.
2. Connect the 48 V output cable tail from the Tripix power device to the “Power” connector on the Tripix Power Inserter cable.
3. Connect the “Out” connector on the Tripix Power Inserter cable to the first Tripix fixture’s power/data input cable tail.
4. Connect the first fixture’s power/data output cable tail to the next fixture’s power/data input cable tail.
5. Continue connecting Tripix fixtures’ power/data output cable tails to input tails to form a chain. Do not exceed the maximum permitted number of fixtures in one chain for the Tripix Power device you are using (see warnings under Tripix system overview on page 19).
6. See Figure 14. When all groups of fixtures are connected correctly, insert a Martin 13-pin DIN DMX Termination Plug in the output connector of the last fixture of each separate chain of fixtures. One plug is supplied with each Tripix Power or Tripix Power IP66. Additional plugs can be ordered from Martin (P/N 91611336).

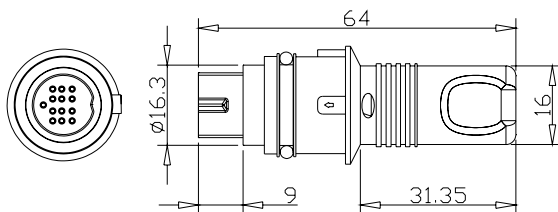

Figure 14: DMX termination plug

7. If DMX control is required, or if you want to configure fixtures using a PC running the Martin MUM application and a USB/DMX interface such as the Martin DABS1™ Hardware Interface (P/N 91611144), connect the output from the DMX controller or USB/DMX interface to the “In” connector of the Power Inserter cable, using a Tripix DMX Input Adapter cable.
8. Apply power and check that the system works as intended.

Extensions and advanced system connections

If the integral cable tails supplied with Tripix devices are too short, the Tripix system can be extended using Tripix Extension Cables or Tripix Cable Adapters.

Tripix Extension Cables

Tripix Extension Cables have the same IP66 connectors as Tripix fixtures and can be inserted anywhere in the link to extend it.

Tripix Cable Adapters

Tripix Cable Adapters are supplied in pairs with male and female cable tails installed. See Figure 15.



Figure 15: Male Tripix Cable Adapter

When installing fixtures outdoors or in a wet or damp environment install each cable adapter's PCB and terminals inside an IP66-rated electrical junction box (not supplied). Ensure that all cable grommets are completely sealed against moisture and dust. Failure to seal the box can lead to damage and risk of electric shock! Use only cable and junction boxes that are approved for installation and conform to all local building, electrical and safety codes.

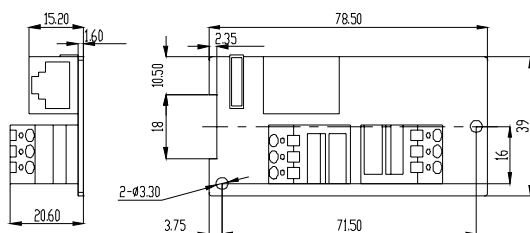

Figure 16: Tripix Cable Adapter dimensions

RJ-45
DMX data
socket

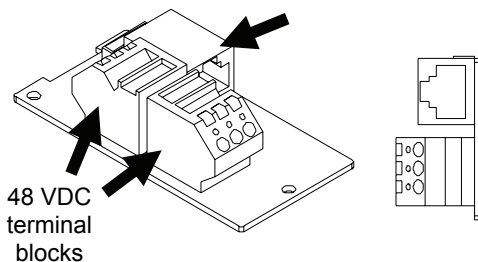

Figure 17: Tripix Cable Adapter

Connecting Cable Adapters

When connecting power cable between the 48 VDC terminal blocks, respect the cable lengths and dimensions given in Table 2.

| Total Length | Cable Conductor Gauges Required |
|------------------------|--|
| 1-15m (3.3-49 ft.) | 16 AWG or 1.0 mm ² |
| 15-40m (49-131ft.) | 14 AWG or 1.5 mm ² |
| 40-80m (131-262ft.) | 12 AWG or 2.5 mm ² |

Table 2: Power cable length and gauges, Tripix Cable Adapters

48 VDC terminals are marked **+**, **-** and **PG** (PG = protective ground / protective earth). When installing 3-conductor power cable to run a power extension from the male to the female cable adapter, connect terminals at both ends as follows:

- Terminals marked **+** to 48 VDC positive
- Terminals marked **-** to 48 VDC negative
- Terminals marked **PG** to ground/earth

To run a data extension from the male to the female adapter, plug in a good quality CAT5e or better cable with RJ-45 connectors. You are recommended not to exceed 50 m.

Extending the DMX data link

If you reach the maximum permitted number of Tripix fixtures for the Tripix power device you are using but you need to add more fixtures, you must create another group of fixtures connected to another Tripix power device to avoid a current overload.

If you want to control or configure all the fixtures together, you must continue the data link from the last fixture in Group 1 to the “In” connector of Group 2’s Power Inserter cable (see Figure 18). The “In” connector of Power Inserter cables only accepts the data signal, so Groups 1 and 2 are powered independently. You can either:

- Connect the output cable tail of the last fixture in Group 1 to the “In” connector of group 2’s Power Inserter cable, or
- Run a Tripix Extension Cable from the output cable tail of the last fixture in Group 1 to the “In” connector of group 2’s Power Inserter cable, or
- Use a pair of Tripix Cable Adapters, IP66, Male + Female (P/N: 91611323 – see Figure 17) with a CAT5e data cable only (no power cable is necessary) to extend the link from the last fixture in Group 1 to the “In” connector of group 2’s Power Inserter cable.

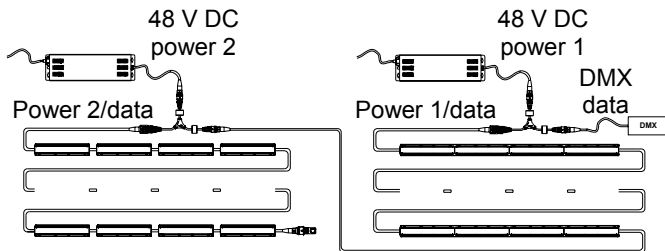

Figure 18: Extending the DMX data link

Extending the power link

1. See Figures 19 and 20. If you need to extend the distance between a Tripix Power device and Power Inserter cable, you can use Tripix Cable Adapters. Only a power cable (arrowed) is needed as no data is transferred.

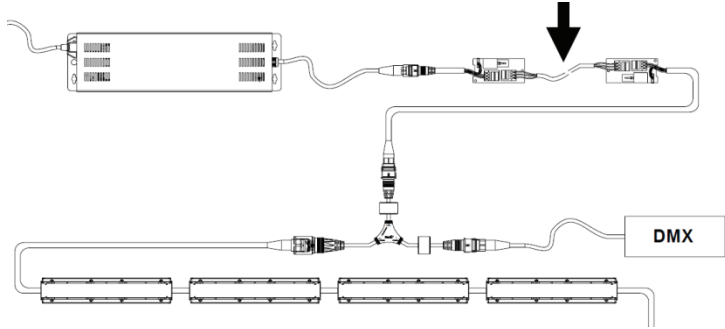

Figure 19: Extending Tripix Power and Power Inserter

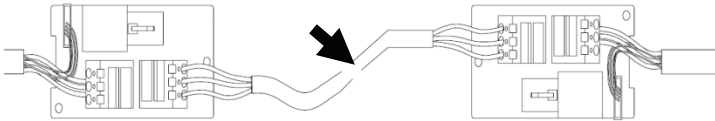

Figure 20: Only power cable needed

2. The dimensions of the power cable you must use for this purpose depend on the length of the power cable. Use the dimensions and lengths given in Table 2 on page 25.

Extending the power/data link

1. See Figures 21 and 22. If you need to extend the distance between the Power Inserter cable and the first fixture, either insert a Tripix Extension Cable or use both a CAT5e data cable and a power cable (arrowed) in Tripix Cable Adapters.

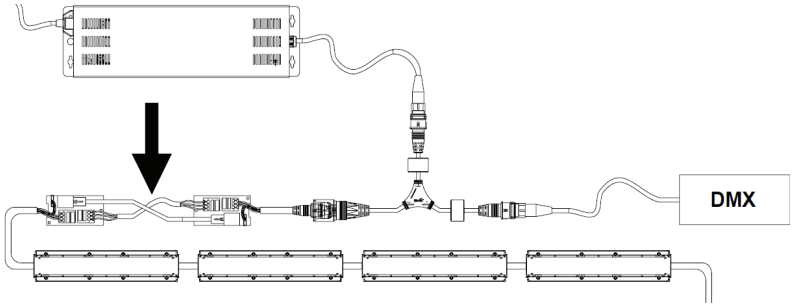

Figure 21: Extending the link to the first fixture

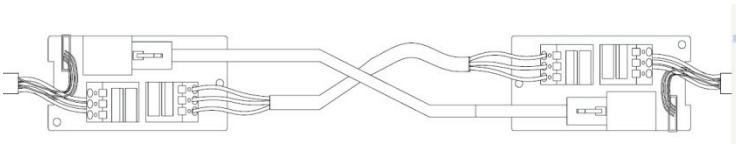

Figure 22: Both power cable and CAT5 cable needed

2. See Figures 23 and 24. If you need to extend the distance between fixtures, either insert a Tripix Extension Cable or use both a CAT5e cable and power cable (arrowed) in Tripix Cable Adapters.

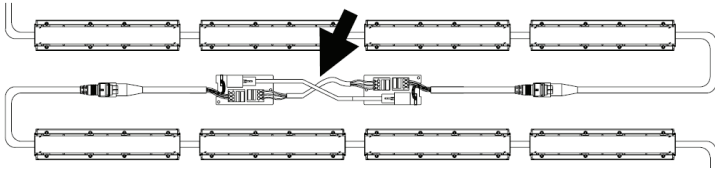

Figure 23: Extending the link

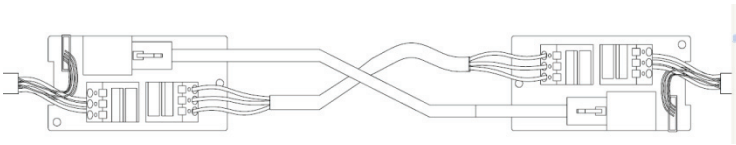

Figure 24: Both power cable and CAT5 cable needed

Continuing a data link to other types of fixture

If you need to continue the DMX data link to other types of fixture that have XLR-type DMX input connections, use the Tripix DMX Output adapter cable (P/N: 91611338) available from Martin.

Fixture configuration

To set up Tripix fixtures for DMX control or stand-alone operation, you will need:

- A Windows PC running the Martin MUM™ (Multi Utility Manager) application, version 1.6.2 or later.
- A Martin DABS1™ USB/DMX (PC to fixture) hardware interface, version 1.4 or later.
- The Tripix Power Inserter cable
- A DMX input adapter cable (P/N 91611337), available from Martin.

Configuring with MUM

The Martin MUM™ (Multi-Utility Manager) PC application allows you to set DMX addresses, DMX mode and pixel mode. It also allows you to enable and adjust stand-alone operation. See also the MUM user manual.

MUM is supplied in a package together with the Martin DABS1 interface (P/N: 9161144). The latest version of MUM is also available for download free of charge from the Martin website at www.martin.com.

Important! We recommend that you set DMX addresses and configure fixtures before physical installation. If you try to use the auto-addressing function and MUM does not recognize all fixtures, address and configure groups or fixtures separately (see “If MUM cannot recognize all the fixtures” on page 39).

To set up the system:

1. Install Tripix fixtures on a DMX link as described earlier. Do not forget to add the DMX terminator at the end of the link.
2. Connect a USB port from the PC to DABS1 RJ45 port.
3. Connect the XLR output from the DABS1 to the DMX input adapter cable and then to the “In” connector of the Power Inserter cable.
4. Connect the output from the Power Inserter cable to the input cable tail of the first Tripix fixture on the link.
5. Apply power to the Power Inserter cable so that the fixtures on the link are powered, wait for fixtures to reset, and then start up MUM.
6. Carry out setup as described below.

This procedure also works for one single fixture, provided that a DMX Termination Plug is installed on the DMX output cable tail of that fixture.

Communicating with a specific fixture

See Figure 25. To communicate with a specific fixture, open the Fixture Settings window in MUM. Use the navigation arrows just above the **Refresh** button near the bottom of the screen to scroll between fixtures. Fixtures are numbered sequentially from the first fixture on the DMX link, and the number of the fixture you are communicating with is displayed above the **Reconnect** button.

Configuring DMX operation

The **Fixture settings** window in MUM (see Figure 25) lets you:

- Use the navigation arrows to communicate with a specific fixture and set that fixture's DMX address in the **DMX Address** box, or
- Automatically set DMX addresses for all the Tripix fixtures on the link using the **Auto address sequentially** button. Depending on which **DMX Mode** and Pixel Mode is selected, MUM will allow from 3 to 16 DMX channels per fixture and allocate DMX addresses in sequence to all the Tripix fixtures on the link starting with the address shown in the **DMX Address** box, or
- Set all the Tripix fixtures on the link to DMX address 1 using the **Reset DMX address to 1** button. If you choose this option, all the Tripix fixtures will react identically to DMX control and behave as one.

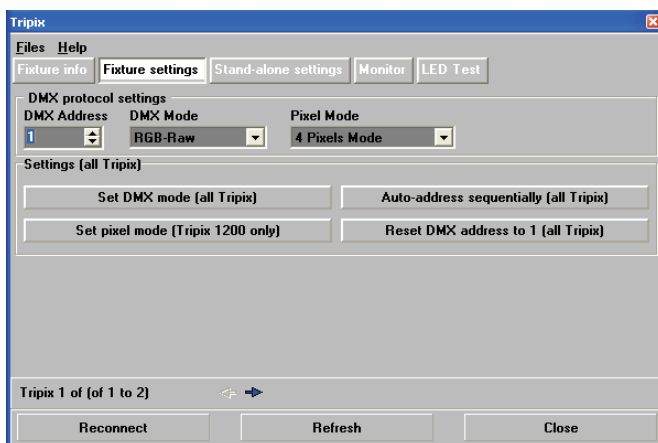

Figure 25: Fixture settings

If you have set a fixture's DMX address manually using the first method listed above, set its DMX and pixel grouping modes before moving on to the next fixture.

Setting DMX mode

Select the DMX color control mode you want to use via MUM (see Figure 26).

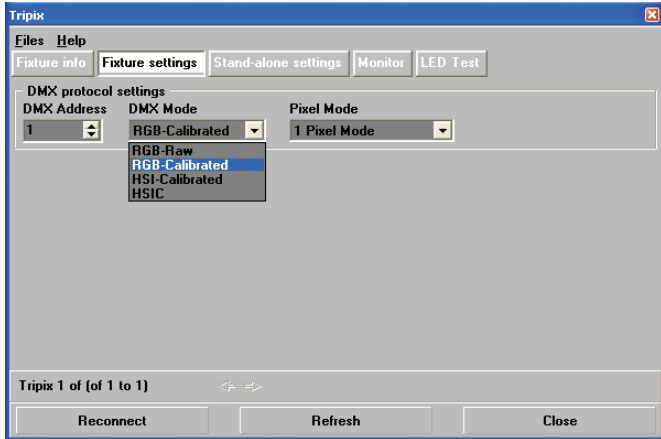

Figure 26: DMX Mode settings

Setting Pixel Mode

For Tripix 1200 and Tripix Wash fixtures, select the pixel grouping mode you want to use via MUM (see Figure 27).

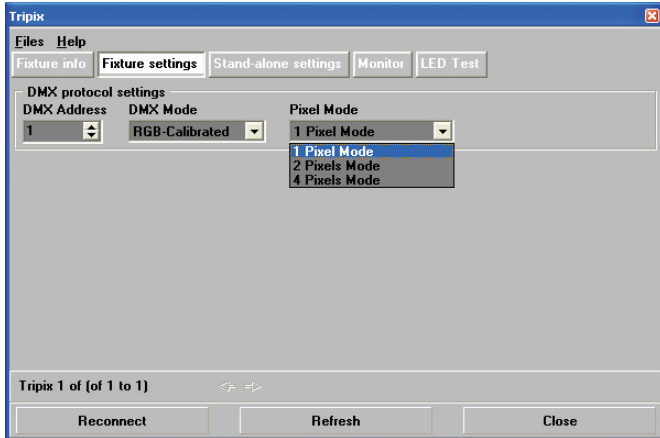

Figure 27: DMX Mode settings

Configuring stand-alone operation

To activate or deactivate stand-alone operation, open the Stand-alone settings window in MUM and set Stand-alone operation to Enabled/Disabled (see Figure 28).

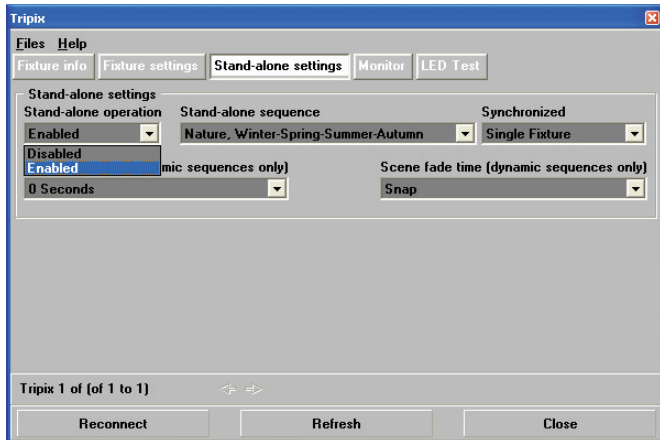

Figure 28: Stand-alone settings

Stand-alone sequence settings

There are 64 static and dynamic stand-alone sequences in total (see Figure 29). Select a sequence to activate it.

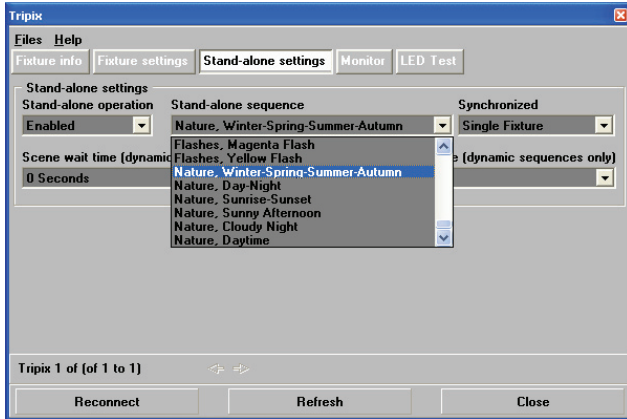

Figure 29: Stand-alone sequence settings

Stand-alone sequence timing

See Figure 30. Stand-alone sequence times can be adjusted in the Stand-alone settings window:

- Wait times (the length of time each step in a dynamic scene is displayed) can be set in the Scene wait time pull-down box.
- Fade time (the speed of the change from one step in a dynamic scene to the next step) can be set using the Scene fade time pull-down box.

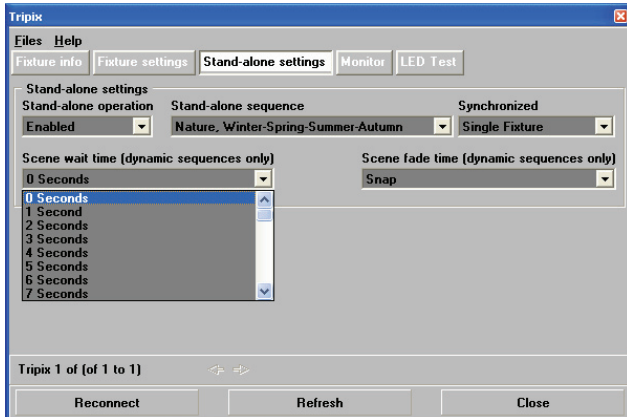

Figure 30: Stand-alone wait and fade times

Stand-alone programs

The stand-alone programs available are listed below.

| Sequence | Style | Name |
|----------|-----------------|-----------------------|
| 0 | SIMPLE COLORS | ALL OFF |
| 1 | | RED |
| 2 | | GREEN |
| 3 | | BLUE |
| 4 | | ALL ON |
| 5 | | CYAN |
| 6 | | MAGENTA |
| 7 | | YELLOW |
| 8 | WHITES | WARM WHITE |
| 9 | | COOL WHITE |
| 10 | | COLD WHITE |
| 11 | | HOT WHITE |
| 12 | TRENDY COLORS | ORANGE |
| 13 | | LIME GREEN |
| 14 | | LEMON YELLOW |
| 15 | | AQUA BLUE |
| 16 | | BABY PINK |
| 17 | | LILAC |
| 18 | | BLOOD ORANGE |
| 19 | | FLESH PINK |
| 20 | | LEAF GREEN |
| 21 | | PURPLE |
| 22 | SIMPLE DYNAMICS | RGB 1 |
| 23 | | RGB 2 |
| 24 | | CMY |
| 25 | | RAINBOW |
| 26 | | W - R - W - G - W - B |
| 27 | | W - C - W - M - W - Y |
| 28 | ALTERNATES I | RED / ORANGE |
| 29 | | RED / PINK |
| 30 | | RED / AQUA |
| 31 | ALTERNATES II | GREEN / YELLOW |
| 32 | | GREEN / BLUE |
| 33 | | GREEN / ORANGE |
| 34 | | BLUE / PURPLE |
| 35 | | BLUE / ORANGE |
| 36 | | BLUE / YELLOW |
| 37 | FADES TO WHITE | RED FADE TO WHITE |
| 38 | | GREEN FADE TO WHITE |

| | | |
|----|-------------------------------|-----------------------------|
| 39 | FADES TO WHITE (continued) | BLUE FADE TO WHITE |
| 40 | | CYAN FADE TO WHITE |
| 41 | | MAGENTA FADE TO WHITE |
| 42 | | YELLOW FADE TO WHITE |
| 43 | PULSES | RED PULSE |
| 44 | | BLUE PULSE |
| 45 | | GREEN PULSE |
| 46 | | CYAN PULSE |
| 47 | | MAGENTA PULSE |
| 48 | | YELLOW PULSE |
| 49 | | WHITE PULSE |
| 50 | | RGB PULSE |
| 51 | | CMY PULSE |
| 52 | FLASHES | RED FLASH |
| 53 | | BLUE FLASH |
| 54 | | GREEN FLASH |
| 55 | | CYAN FLASH |
| 56 | | MAGENTA FLASH |
| 57 | YELLOW FLASH | |
| 58 | NATURE | WINTER-SPRING-SUMMER-AUTUMN |
| 59 | | DAY-NIGHT |
| 60 | | SUNRISE-SUNSET |
| 61 | | SUNNY AFTERNOON |
| 62 | | CLOUDY NIGHT |
| 63 | | DAYTIME |

Single-fixture and synchronized operation

Important! Do not set more than one fixture on a link as master.

In synchronized operation, a master fixture playing a stand-alone program relays instructions via the DMX link that cause slave fixtures to run identical synchronized programs.

Synchronized operation is set up in the Synchronized pull-down box in the Stand-alone settings window. See Figure 30. Settings are applied to the fixture you connect to using the navigation arrows.

- In **Single Fixture** mode, a Tripix runs its own stand-alone program and ignores all other fixtures.
- In **Master** mode, the Tripix sends stand-alone instructions to slave fixtures so that they run an identical program to the master. Colors and fade/wait times in slave fixtures will be identical to the master's. Do not set more than one fixture on the DMX link as master.

- In **Synchronized** mode, the Tripix is a slave and obeys instructions from a master fixture.
- Four buttons also allow you to apply settings to all Tripix fixtures on the DMX link:
 - **Set all as single fixture** sets all fixtures to run their own stand-alone program independently of the other fixtures
 - **Set all as single fixture - synchronized sequence and timing selections** sets all fixtures to run the stand-alone program you have selected in MUM: scene changes are synchronized and wait/fade times are identical.
 - **Set this fixture as master, rest as synchronized** sets the fixture you are connected to as master with the stand-alone program you have selected in MUM. The other fixtures follow the master fixture's stand-alone program.
 - **Disable stand-alone for all Tripix** takes all fixtures out of standalone mode leaving them ready for DMX control.

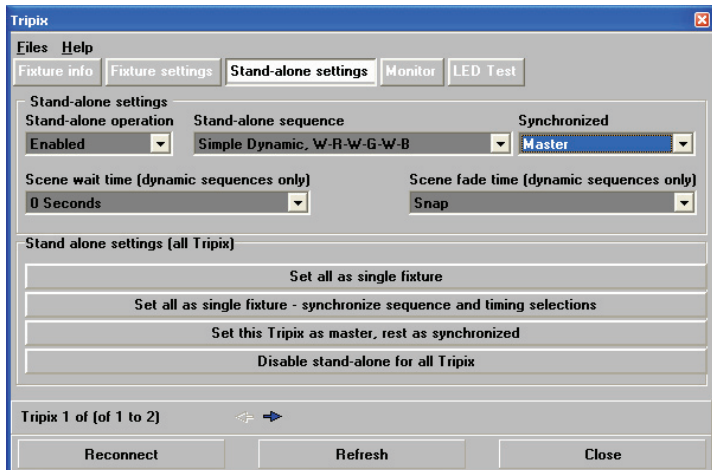

Figure 30: Synchronized operation settings

If MUM cannot recognize all the fixtures

If MUM cannot recognize all the fixtures on a DMX link after you have connected MUM to the start of the link, connect MUM directly to any group with unrecognized fixtures to configure that group. To connect to a group, temporarily plug MUM into that group's Power Inserter cable's "In" connector.

If MUM does not recognize all the fixtures in a group, connect MUM directly to each unrecognized fixture. To connect to a fixture, temporarily connect a Tripix Power device and Power Inserter cable to that fixture and plug MUM into the Power Inserter cable's "In" connector.

Operation



Warning! Do not view the light output with optical instruments or any device that may concentrate the beam.

Ambient temperatures

Tripix fixtures and the Tripix Power IP66 can be operated at ambient temperatures from -30° C (-22° F) to 45° C (113° F). The Tripix Power can be operated from -30° C (-22° F) to 40° C (104° F)

DMX-controlled operation

When the Tripix system is set up for DMX-controlled operation, faders on the DMX controller are used to control color and intensity. The control method depends on which color control mode the Tripix system is set to:

| Channel | Value | Percentage | Function |
|---------|-------|------------|------------------------|
| 1 | 0-255 | 0-100% | Red Intensity 0-100% |
| 2 | 0-255 | 0-100% | Green Intensity 0-100% |
| 3 | 0-255 | 0-100% | Blue Intensity 0-100% |

Table 3: RGB mode (raw* and calibrated)

**Raw = uncalibrated*

| Channel | Value | Percentage | Function |
|---------|-------|------------|--|
| 1 | 0-255 | 0-100% | Hue Red>>Orange>>Amber>>Yellow >>Green>>Cyan>>Blue>>Indigo >>Violet>>Magenta>>Red |
| 2 | 0-255 | 0-100% | Saturation Zero(White)>>Full |
| 3 | 0-255 | 0-100% | Intensity: 0-100% |

Table 4: HSI mode (calibrated)

| Channel | Value | Percentage | Function |
|---------|-------|------------|--|
| 1 | 0-255 | 0-100% | Hue Red>>Orange>>Amber>>Yellow >>Green>>Cyan>>Blue>>Indigo >>Violet>>Magenta>>Red |
| 2 | 0-255 | 0-100% | Saturation Zero(White)>>Full |
| 3 | 0-255 | 0-100% | Intensity: 0-100% |
| 4 | 0-255 | 0 -100% | Color Temperature Control 2000 - 10000 K |

Table 5: HSIC mode (calibrated)

Pixel grouping mode

If Tripix 1200 and Tripix Wash are set to 2 or 4 pixel mode, the DMX channels used are available for each pixel.

For example, a Tripix 1200 in 4-pixel HSIC mode will use 16 channels: the first 4 channels will control HSIC on pixel 1. Channel 5 to 8 will control HSIC on pixel 2, and so on.

Service and maintenance



Warning! Read “Safety Information” on page 3 before carrying out service or maintenance work on the Tripix system. Lock out power to the entire distribution system and allow fixtures to cool before servicing or opening any cover.

Important! Opening the fixture by anybody else but a Martin Distributor may damage the IP66 seal and will void the warranty!

Important! The Tripix system requires regular service and maintenance to maintain reliable operation and protect the investment it represents. Excessive dirt and particle build-up degrades performance, causes overheating and will damage Tripix fixtures and power supply devices. Damage caused by inadequate cleaning or maintenance is not covered by the product warranty.

The service and maintenance procedures described in this section must be carried out by qualified professionals only. Any service procedures not described in this section must be carried out by the Martin Service organization or its authorized agents.

It is Martin policy to use the best quality materials available to ensure optimum performance and the longest possible component lifetimes. However, optical components in all lighting fixtures are subject to wear and tear over the life of the Tripix fixture, resulting in gradual changes in color rendition, for example. The extent of wear and tear depends heavily on operating conditions and environment, so it is impossible to specify precise lifetimes for optical components.

Cleaning



Warning! Do not use a high-pressure water jet for cleaning.

Regular cleaning is essential for fixture life and performance. Build up of dust and dirt degrades the fixture’s light output and cooling ability.

Cleaning schedules will vary greatly depending on the operating environment. It is therefore impossible to specify precise cleaning intervals for the Tripix system. Inspect fixtures within their first few weeks of operation to see whether cleaning is necessary. Check again at frequent intervals. This procedure will allow you to assess cleaning requirements in your particular situation. If in doubt, consult your Martin dealer about a suitable maintenance schedule.

Clean the Tripix Power, Tripix Power IP66 and the Tripix fixture housing and front cover with a soft cloth dampened with a solution of water and

a mild detergent such as car shampoo. Take care not to damage cables during cleaning. Do not use products that contain solvents, abrasives or caustic agents for cleaning, as they can cause surface damage to the housing and the front cover.

Fixture information and monitoring

See Figure 31. The Fixture info window displays basic information for the fixture. Power-on hours and LED operation hours are also displayed. Two counters are available for each: an absolute and a resettable counter:

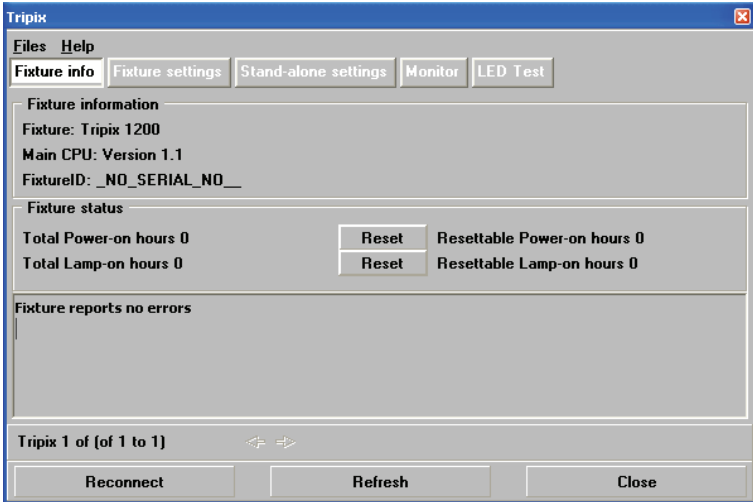

Figure 31: Fixture info window

See Figure 32. The Tripix displays voltage readouts for 48V and 5V components as well as temperature readouts for LEDs and the main PCB in the Monitor window:

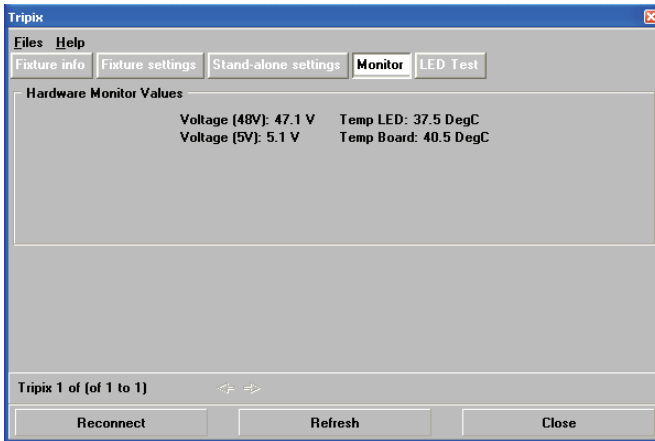

Figure 32: Monitor window

Testing

See Figure 33. The LED Test window in MUM gives a quick method of testing LED output at 100% intensity without a DMX controller.

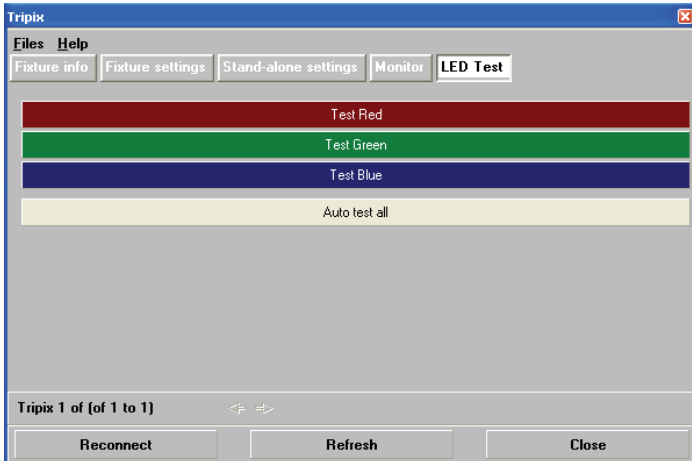

Figure 33: LED test window

Diffuser Filters

Important! Install diffuser filter sheets with their matt, textured surfaces and shiny, untextured surfaces facing as described below for the individual Tripix models. You can distinguish between the matt, textured surface and shiny, untextured surface by touching them with your fingers.

Tripix 300, 1200 and Wash fixtures are supplied with a narrow beam angle diffuser installed. The diffuser softens the output from the LEDs and alters the beam angle.

Diffuser filters are available in three different beam angles: narrow, medium and wide. Diffusers can be ordered from Martin (see “Accessories” on page 52).

Installing a Tripix 300/1200 diffuser

1. Disconnect the Tripix fixture from power. If the fixture has been in use, allow it to cool for at least 5 minutes.
2. Remove the fixture from the DIN rail by using a 2.5mm Allen key to release the mounting clamp screw and then unhooking the mounting bracket from the DIN rail. Place the fixture on a horizontal surface with the front cover facing up.
3. Remove the front cover screws and the front cover (See Figure 34).

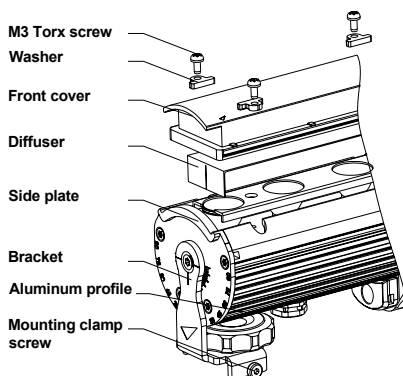

Figure 34: Tripix 300/1200 diffuser location

4. Remove the old diffuser filter (if fitted) and install the new diffuser by putting it into the front cover with its *matt side facing out towards the front* and with its *shiny side facing in towards the LEDs*. To

avoid light leakage, bend the edges of the diffuser as shown in Figure 35.

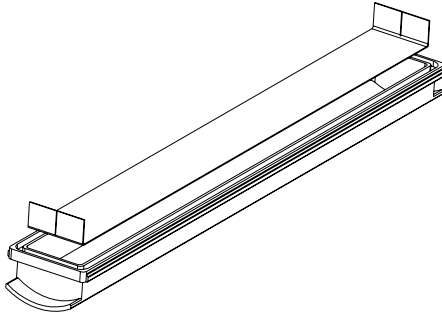

Figure 35: Installing the Tripix 300/1200 diffuser

5. Check that the front cover seal is correctly seated in its slot all the way round the edge of the front cover. If the seal is not correctly seated, use one hand to press the seal into its slot in one place, then use the other hand to press the seal into the slot, moving round the slot until the seal is correctly seated all the way round the front cover.
6. Put the front cover back and cross-tighten all screws gradually in steps to a torque of $1.0 \text{ Nm} \pm 0.1 \text{ Nm}$.

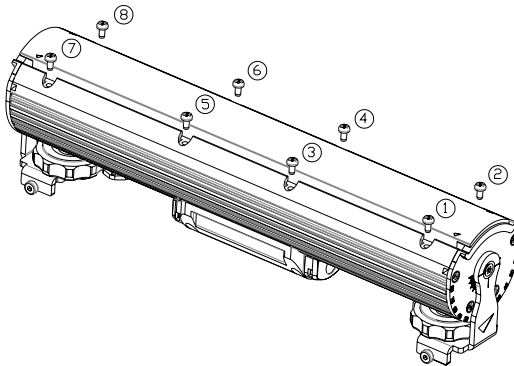

Figure 36: Front cover screws

Installing a diffuser filter in the Tripix Wash

1. Disconnect the Tripix Wash from power. If the fixture has been in use, allow it to cool for at least 5 minutes.
2. Remove the screws from the fixture housing to release the front cover (See Figure 37).

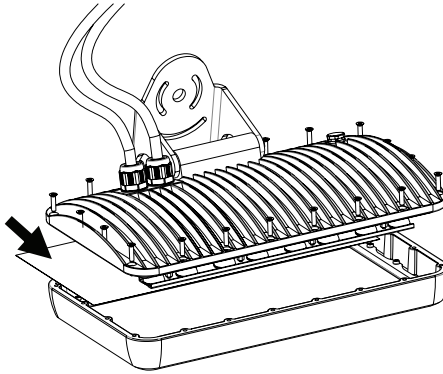

Figure 37: Remove the screws

3. Remove the old diffuser filter (if fitted) and install the new diffuser (arrowed in Figure 37) by putting it into the front cover with its *mat side facing in towards the LEDs* and its *shiny side facing out towards the front*.
4. Set the fixture upright (see figure 38) and check that the front cover seal is correctly seated in its slot all the way round the edge of the fixture housing. If the seal is not correctly seated, use one hand to press the seal into its slot in one place, then use the other hand to press the seal into the slot, moving round the slot until the seal is correctly seated all the way round the housing.

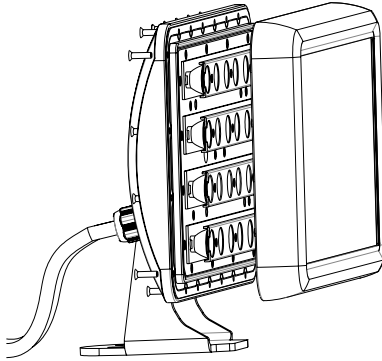

Figure 38: Reinstalling the front cover

5. Without disturbing the seal, reinstall the front cover, cross-tightening screws gradually in steps to a torque of $1.6 \text{ Nm} \pm 0.1 \text{ Nm}$.

Fuse replacement



Warning! Lock out power to the entire distribution system before servicing or opening any cover. Replace fuses with ones of the same type and rating only. Do not attempt to bypass a fuse.

Tripix Power IP66

The fuse in the Tripix Power IP66 must be replaced by Martin Service or its authorized agents only.

Tripix Power

The fuse in the Tripix Power can be replaced by the user following the warnings and instructions below.

The Tripix Power is protected by a 6.3 amp slow-blow primary fuse. If the Tripix Power is completely dead, the primary fuse may have been blown.

To replace the fuse:

1. Disconnect the Tripix Power from power.
2. See Figure 39. Open the fuseholder located next to the power cable entry with a flathead screwdriver and remove the fuse.

3. Replace the fuse with one of the same type and rating.
4. Replace the fuseholder.
5. If fuses continue to blow, there is probably a fault. Disconnect the device from power and data and contact a Martin service technician for assistance.

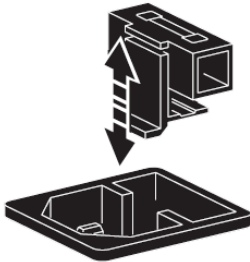

Figure 39: Tripix Power Fuseholder

Software installation

It may be necessary to upload new software (i.e. firmware) to the Tripix fixtures if you believe that the product has a software-related fault or if you want to update to a newer version. Software updates are available from the Martin website (<http://www.martin.com>) and can be installed via the DMX data link with the following items:

- A Martin Universal USB-DMX Interface or Martin USB Duo DMX Interface (P/N 90703010) and a Windows PC.
- The Martin Uploader application, version 5.0 or later, downloadable free of charge from the “After-Sales” area of the Martin website.
- The Tripix main software update file, downloadable free of charge from the “After-Sales” area of the Martin website (this file can be downloaded automatically from within the Martin Uploader application)

Installing software

To install software in the Tripix fixtures:

1. Connect the Uploader hardware to the Tripix fixture data input connector.
2. Upload the software as described in the Martin Uploader help file or user documentation. The LEDs will flash during the upload.

3. When the upload is completed, the fixture will go back to the previous status before upload.
4. Software uploads can fail (most failures are caused by interference on the data link). Turn off power and repeat the upload. If the problem persists, contact the Martin Service organization or its authorized agents for assistance.

Troubleshooting

| Problem | Probable cause(s) | Remedy |
|--|--|---|
| Power and fixture are completely dead | No power to Tripix Power | Check power and connections. |
| | Primary fuse blown (located in fuseholder on front panel of Tripix Power) | Isolate fixture from power. Check fuse and replace. |
| One or more fixtures respond incorrectly to control or do not respond at all | Fault on DMX link | Inspect connections and cables. Correct poor connections. Repair or replace damaged cables. |
| | Incorrect DMX addressing | Check Tripix fixture is set to correct DMX mode. Check Tripix fixture's DMX address and channels assigned to it at controller. |
| | Other device on DMX link defective | Bypass devices on DMX link until the faulty device has been identified. Have faulty device tested and serviced by Martin service or device supplier. |
| | Wrong fixture configuration | Check the fixture configuration. |
| LEDs cut out intermittently | Tripix Power is too hot | Ensure free airflow around Tripix Power. Clean the Tripix Power. Check that ambient temperature does not exceed maximum permitted level. Contact Martin for service. |
| Uneven color at very low levels (below 10% or DMX value 25) | Unstable LED output at low levels can occur due to direct drive technology used in Tripix. | Keep DMX values above 25 in static cues. Run quickly through DMX values 0 – 25 during fades. |

Table 7: Troubleshooting

Specifications

Physical

Tripix 1200 / 300

| | |
|--------------|---|
| Length | 1200 mm (47.2 in.) / 300 mm (11.8 in.) |
| Width | 61 mm (2.4 in.) including mounting bracket |
| Height | 82 mm (2.8 in.) including mounting bracket and DIN rail |
| Weight | 4230 g (9.4 lb.) / 1200 g (2.7 lb.) |

Tripix Wash

| | |
|--------------|---|
| Length | 335 mm (13.2 in.) |
| Width | 132 mm (5.2 in.) including mounting bracket |
| Height | 231 mm (9.1 in.) including mounting bracket |
| Weight | 4650 g (10.3 lb.) |

Tripix Power / Tripix Power IP66

| | |
|--------------|---------------------------------------|
| Length | 447 mm (17.6 in.) / 314 mm (12.4 in.) |
| Width | 141 mm (5.5 in.) / 68 mm (2.7 in.) |
| Height | 68 mm (2.7 in.) / 39 mm (1.5 in.) |
| Weight | 5.8 kg (12.8 lb.) / 1.5 kg (3.3 lb.) |

Dynamic Effects

| | |
|---------------------------------|------------------------------------|
| Color mixing | RGB |
| Red | 0 - 100% |
| Green | 0 - 100% |
| Blue | 0 - 100% |
| Color temperature control | 2 000 - 10 000 K continuous mixing |

Control and Programming

| | |
|---------------------------|---|
| Color control modes | RGB (raw & calibrated), HSI and HSIC (calibrated) |
| Control options | DMX, stand-alone and synchronized master/slave |
| DMX | USITT DMX512-A |
| DMX address setting | Martin MUM™ application, Windows PC |
| Receiver | RS-485 |
| Firmware update | Serial upload via DMX link |

Optics

| | |
|-----------------------|---------------------------|
| Light source | 3-in-1 LED |
| Total LED power | Tripix 300: 24 W approx. |
| | Tripix 1200: 82 W approx. |
| | Tripix Wash: 72 W approx. |

For photometric data see www.martin.com

Construction

Tripix 300, 1200 and Wash Fixtures

| | |
|-------------------|----------------|
| Housing | Aluminum |
| Finish | Clear anodized |
| Front cover | PMMA |
| IP rating | IP 66 |

Tripix Power

| | |
|-----------------|--------------------|
| Housing | Steel |
| Finish | Grey powder-coated |
| IP rating | IP 20 |

Tripix Power IP66

| | |
|-----------------|----------------|
| Housing | Aluminum |
| Finish | Clear Anodized |
| IP rating | IP 66 |

Installation

| | |
|-----------------------|---|
| Orientation | Any |
| Vertical aiming | +/- 95° |
| Mounting points | mounting brackets or 35 mm DIN top-hat rail |

Maximum number of fixtures connected per Tripix Power

| | |
|---|------------------|
| Tripix 300 | 24 |
| Tripix 1200 | 6 |
| Tripix Wash | 6 |
| Mixture of Tripix 300, 1200 and Wash (Wash counts as 1200) | 7.2 m (23.6 ft.) |

Maximum number of fixtures connected per Tripix Power IP66

| | |
|---|------------------|
| Tripix 300 | 12 |
| Tripix 1200 | 3 |
| Tripix Wash | 3 |
| Mixture of Tripix 300, 1200 and Wash (Wash counts as 1200) | 3.6 m (11.8 ft.) |

Connections

- AC power input, Tripix Power Male (C14) IEC socket
- AC power input, Tripix Power IP66 Hard-wired, screw terminals
- Tripix fixtures interconnection, power and data 13 pin DIN, IP66

Electrical

- AC power 100-240 VAC nominal, 50/60 Hz (Tripix Power)
- Main fuse 6.3 AT (Tripix Power)
- AC power 100-240 VAC nominal, 50/60 Hz (Tripix Power IP66)

Thermal

- Cooling All devices convection-cooled
- Maximum ambient temperature (Ta.max.)
 - Fixtures and Tripix Power IP66 45° C (113° F)
 - Tripix Power 40° C (104° F)
- Minimum ambient temperature (Ta min.) -30° C (-22° F)
- Maximum surface temperature, steady state, Ta=45° C:
 - Fixtures 65° C (149° F)
 - Tripix Power 55° C (131° F)
 - Tripix Power IP66 80° C (176° F)

Approvals



- EU Safety EN 60598-1, EN 60598-2-1
- LED Safety IEC 60825-1, 2001; IEC 62471, 2006
- EU EMC EN 55 015, EN 55 103, EN 61 000-3
- US Safety UL 1598
- Canadian Safety CAN/CSA C.22.2 No. 250

Included Items

Tripix 300, Tripix 1200 and Tripix Wash

- 1 x luminaire with narrow diffuser installed

Tripix Power

- 1 x Tripix Power
- 1 x Power Inserter cable
- 2 x power cables (EU plug/US plug)
- 1 x User manual

Tripix Power IP66

- 1 x Tripix Power IP66
- 1 x Power Inserter cable
- 1 x User manual

Spare parts

Tripix Power

- 6.3 A slow-blow fuse..... P/N 05020060

The Tripix Power IP66 fuse must be replaced by Martin Service or its authorized agents only.

Accessories

- 0.5 m Extension Cable P/N 91611335
- 1.0 m Extension Cable P/N 91611334
- 5.0 m Extension Cable P/N 91611333
- Set of 8 Tripix Diffusers, Narrow, 300 mm..... P/N 91611329
- Set of 8 Tripix Diffusers, Medium, 300 mm..... P/N 91611330
- Set of 8 Tripix Diffusers, Wide, 300 mm P/N 91611331
- Set of 4 Tripix Wash Diffusers, Narrow..... P/N 91610038
- Set of 4 Tripix Wash Diffusers, Medium P/N 91610036
- Set of 4 Tripix Wash Diffusers, Wide P/N 91610037
- Tripix Power Inserter (3-way power & data insertion cable) .. P/N 91611339
- Short Martin 35 mm DIN rail in 72 mm (2.8 in.) lengths..... P/N 23819560
- Tripix DMX Termination Plug..... P/N 91611336
- Tripix DMX Input Adapter
 - 3-pin male XLR to 13-pin female DIN . P/N 91611337
- Tripix DMX Output Adapter
 - 13-pin male DIN to 3-pin female XLR . P/N 91611338
- Cable Adapter, IP66, male + female..... P/N 91611323
- Cartridge fuse 5×20 mm, T6.3A P/N 05020060

Fixtures are supplied with narrow diffusers installed. Different diffusers can be ordered and installed by a Martin Distributor only. Please indicate angles and models at time of order.

Related Items

- MUM (Multi Utility Manager) incl. DABS interface & cables... P/N 90758090
- Martin USB Duo DMX Interface..... P/N 90703010
- Martin ColorFox VX01 P/N 90734500
- Martin LightFox P/N 90734540

Ordering Information

| | |
|-------------------------|--------------|
| Tripix 300 | P/N 90354520 |
| Tripix 1200..... | P/N 90354530 |
| Tripix Power..... | P/N 90760310 |
| Tripix Power IP66 | P/N 90760330 |

Custom colors are available by special order – please contact your Martin distributor for details.

Specifications subject to change without notice. Please see www.martin.com for latest product information and specifications.

Notes

Notes



Martin[®]

www.martin.com • Olof Palmes Allé 18 • 8200 Aarhus N • Denmark

Tel: +45 8740 0000 • Fax +45 8740 0010