

Micro Terminal Blocks

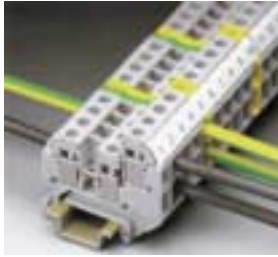

MT-TWAIN and MT-TWIN-PE

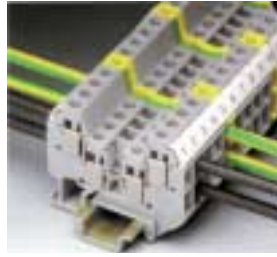

MT-QUATTRO and MT-QUATTRO-PE

These Micro-Terminal blocks feature compact construction (4.2mm wide), are bridgeable in the center, have matching ground blocks and mount on NS 15 rails. **MT1.5** 9not shown) is a 2 conductor block (1-input, 1-output), **MT1.5-TWIN** has 1-input, 2 outputs and **MT 15 QUATTRO** provides 2-inputs and 2 outputs. MTTB1.5 (not shown) is a double level block with two independently bridgeable thru levels. It features universal mounting for both NS 15 and NS35 rails. **Color:** gray (blue available); ground blocks are yellow/green. **Connections:** clamping screws **Flammability Rating:** UL94VO. **Approvals:** UL recognized, CSA certified. Accessories sold separately. **Note:** ground blocks include white labels w/ground symbols.

Mfr's Type	Order No.	Description	AWG	Rating		Dimensions (mm)			Each
				V	A	W	L	H (NS 35: 7.5/NS 15)	
MT 1.5	3100305	Micro Term. Block, 2-Conductor, Gray	26-16	400	17.5	4.2	22	-/23.5	00.00
MT 1.5-TWIN	3001682	Micro Term. Block, 3-Conductor, Gray		400	17.5		28	-/30	
MT 1.5-QUATTRO	3001679	Micro Term. Block, 4-Conductor, Gray		400	16		3.5	-/30	
MTTB 1.5	1414129	DbL.Lvl. Micro-Term. 4-Conductor, Gray		400	17.5		44	41/41	
MT 1.5-PE	3100318	Micro Ground Term. Block for MT 1.5			22	-23.5	
MT 1.5 TWIN-PE	3001705	Micro Ground Term. Block for MT 1.5-TWIN			28	-/30	
MT 1.5-QUATTRO-PE	3001695	Micro Ground Term. Block for MT 1.5-QUATTRO			33.5	-/30	

Accessories for Micro Terminal / Blocks

Mfr's Type	Order No.	Description *	For Terminal Blocks	Each
D-MT 1.5 D-MT 1.5-TWIN D-MT 1.5QUATTRO D-MTTB 1.5	3100321 3002979 3002982 3002665	End Cover, Gray, 1mm wide	MT 1.5 MT 1.5-TWIN MT 1.5QUATTRO MTTB 1.5	00.00
FBRN 10-4N	3001624	Fixed Bridge, 10 pos., Breakable	MT 1.5, MT 1.5-TWIN, MT 1.5QUATTRO, MTTB 1.5	
DG-MTTB 1.5	3002678	Spacer Cover, Gray, 2mm Thick	MTTB 1.5	
DP-MTTP 1.5	3002681	Spacer Plate, Gray, 2mm Thick	MTTB 1.5	
ZBFM 4	...	Marker Strip (order data, see "Accessories for Terminal Blocks")	Fits all Terminal Blocks above	

* Spacer cover and plate compensate for level offset if standard terminal blocks are to be aligned.

Mini Terminal Blocks

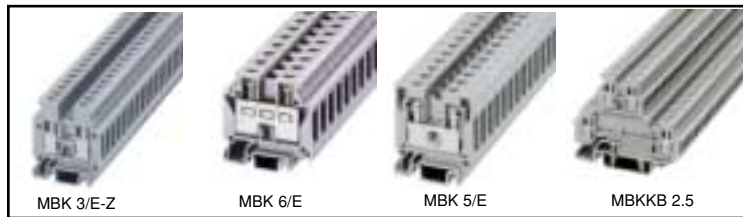

These Mini-Terminal blocks range in width from 5.2mm to 8.2mm and are bridgeable for simple and reliable power distribution. They mount on **NS 15** DIN rails except **MBKKB 2.5** which features universal mounting for both **NS 15** and **NS 35** DIN Rails. **MBK3/E-Z** and **MBK6/E** are single level blocks with 1-input and 1 output. Type **MBK5/E** is also single level (without label groove) and snap-fits on to the mounting rail. Type **MBKKB2.5** is a double level with two bridgeable inputs and outputs. Color: gray, but all except **MBK6/E** are available with blue housing. **Flammability Rating:** UL94V2. **Connections:** Screw Clamps. **Approvals:** UL Recognizable, CSA Certified.



Mfr's Type	Order No.	Description	AWG	Rating		Dimensions (mm)			Each
				V	A	W	L	H (NS 35: 7.5/NS 35: 15NS/15)	
MBK 3/E-Z	1413036	Mini Terminal Block, 2-Conductor, Gray	24-12	500	32	5.2	28	-/32	00.00
MBK 6/E	0552024	Mini Terminal Block, 2-Conductor, Gray	20-8	500	57	8.2	35	-/36	
MBK 5/E	1415076	Mini Terminal Block, Snap Mnt., 2-Cond., Gray	24-12	500	32	6.2	28	-/32	
MBKKB 2.5	1413052	Mini Terminal Block, DbL. Lvl., 4-Cond., Gray	24-12	500	24	5.2	62	47.5/48/55.5	

Accessories for Mini Terminal Blocks

Mfr's Type	Order No.	Description *	For Terminal Blocks	Each
D-MBK/E D-MBK 6/E D-MBKKB 2.5	1415021 1413049 1413052	End Cover, Gray 1mm wide 1.5mm wide 2.5mm wide	MBK 3/E-Z, MBK 5/E MBK 6/E MBLKB2.5	00.00
FBRN 10-5N FBRN 10-8 FBRN 10-6 FBRN 10-5N	2770642 0203263 0203250 2770639	Fixed Bridge, 10-Pos., Breakable	MBK 3/E-Z MBK 6/E MBK 5/E MBKKB 2.5	
EBL 10-5 EB 10-8 EB 10-6 EB 10-5	2303132 0202138 0201139 1401132	Insertion Bridge, 10-Pos., Breakable	MBK 3/E-Z MBK 6/E MBK 5/E MBKKB 2.5	
DP-MBKKB 2.5	1413065	Spacer plate, Gray, 2.5mm Thick	MBKKB 2.5	
ZB5 ZB8	Marker Strip (Order data, See "Accessories for terminal Blocks".)	MBK 3/E-Z, MBKKB 2.5 MBK 6/E	

Spacer plate compensates for level offset if standard blocks are to be aligned.



Universal terminal blocks for many applications can be wired fast and reliably, can be bridged and can be labeled on both sides. These blocks have a universal base which snaps into NS 32 and NS 35 ( or ) mounting rails. UKH series high current terminal blocks are enclosed and require no end covers. Color: Gray (Blue available). **Connections:** Screw Clamps. **Flammability Rating:** UL94VO (UL94V2 for UK 2.5N, UK 3N, UK 16N). **Approvals:** UL Recognized, CSA Certified. European approvals available upon request. A full range of accessories are available (Ordered Separately).

Mfr's Type	Order No.	Description	AWG	Rating		Dimensions (mm)				Each
				V	A	W	L	H (NS 35: 7.5/NS 15)		
UK 1.5N UK2.5N UK 3N UK5N UK 6N UK10N UK16N UK 35	3005837 3003347 3001501 3004362 3004524 3005073 3006043 3008012	Universal Terminal Block, Gray	26-16 24-14 24-12 24-10 24-8 20-6 12-4 18-0	500 800 80 800 800 800 800 1000	17.5 24 32 41 57 76 101 150	4.2 5.2 5.2 6.2 8.2 10.2 12.2 15.2	42.5 42.5 42.5 42.5 42.5 42.5 42.5 50	42/49.5/47 42/49.5/47 47/54.5/52 47/54.5/52 47/54.5/52 47/54.5/52 54/61.5/59 62/69.5/67	00.00	
UKH 50 UKH 95 UKH150 UKH240	3009118 3010013 3010110 3010217	Universal High Current Terminal Block, Gray	6-0 4-000 2-300 00-500	1000 1000 1000 1000	150 232 309 415	20 25 31 36	70.5 83 100 100	.../83.5/81.5 .../97.5/95.5 .../118.5/116 .../131.5/129.5		

Accessories Table

The accessories below are the most common. A wider range of accessories can be found on the page entitled "Accessories for Terminal Blocks" which follows this section. Fixed Bridge: a 10-position breakable screw strip w/insulated collars for voltage bridging in the Terminal center. Insertion Bridge: a 2,3 or 10-position fully insulated, breakable strip for voltage bridging at the connection points. Notes: All bridges have a load capacity of at least 70% of nominal current. Marker Strips: Snap-in Labels (Several variations).

Mfr's Type	Order No.	Description *	For Terminal Blocks	Each
D-UK 2.5 D-UK 4/10 D-DU 16	3001022 3003020 3006027	End Cover, Gray 1.5mm wide 1.8mm wide 1.5mm wide	UK 1.5N, UK 2.5N UK 3N, UK5N, UK 6N, UK 10N UK 16N	00.00
FBRI 10-4N FBRI 10-5N FBI 10-6 FBI 10-8 FBI 10-10 FBI 10-12 FBI 2-15 FBI 3-15 FBI 2-20 FBI 3-20	3001624 2770642 0203250 0203263 0203276 0203454 0201333 0201278 0201346 0201317	Fixed Bridge, 10-Pos, Breakable Fixed Bridge 2-Pos. 3-Pos. 2-Pos. 3-Pos.	UK 1.5 N UK 2.5, UK 3N UK5N UK 6N UK 10N UK16N UK 35 UK 35 UKH 50 UKH 50	
EBL 10-5 EB 10-6 EB 10-8 EB 10-10 EB 10-12 EB 10-15 EB 2-25 UKH EB 3-25/UKH EB 2-31/UKH EB 3-31/UKH EB 2-36/UKH EB 3-36/UKH	2303132 0201139 0202138 0203137 3006137 0205135 0201362 0201375 0201388 0201391 0201401 0201414	Insertion Bridge, 10-Pos., Breakable Insertion Bridge, Snap Fitted 2-Pos. 3-Pos. 2-Pos. 3-Pos. 2-Pos. 3-Pos.	UK 2.5N, UK 3N UK 5N UK 6N UK 10 UK 16N UK 35 UKH 95 UKH 95 UKH 150 UKH 150 UKH 240 UKH 240	
ZB 4 ZB 5 ZB 6 ZB 8 ZB 10	Marker Strips (Order data, See "Accessories for Terminal Blocks")	UKH1.5N UK 2.5N, UK 3N UK 5N UK 6N UK 10, UK 16N, UK 35, UKH 50, UKH 95, UKH 150, UKH 240	

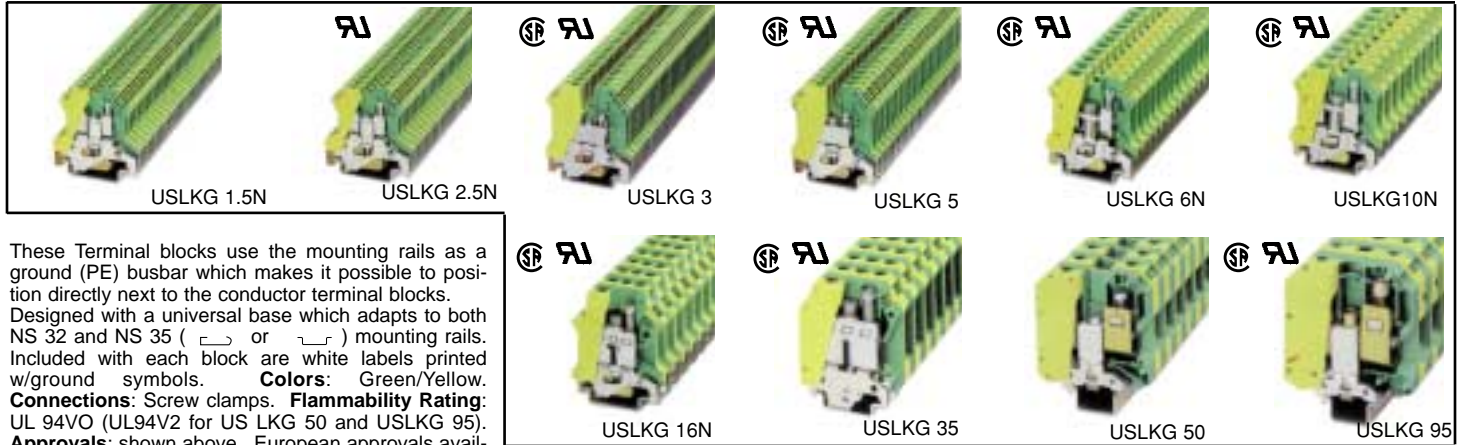

These Terminal blocks use the mounting rails as a ground (PE) busbar which makes it possible to position directly next to the conductor terminal blocks. Designed with a universal base which adapts to both NS 32 and NS 35 (or) mounting rails. Included with each block are white labels printed w/ground symbols. **Colors:** Green/Yellow. **Connections:** Screw clamps. **Flammability Rating:** UL 94V0 (UL94V2 for US LKG 50 and USLKG 95). **Approvals:** shown above. European approvals available. **Accessories:** ZB Series marker strips (order data, see "Accessories for Terminal Blocks").

Mfr's Type	Order No.	Description	AWG	Rating		Dimensions (mm)			Each
				V	A*	W	L	H (NS 35: 7.5/NS 35:15/NS 32)	
USLKG 1.5N	3005853	Universal Ground Terminal Blocks	26-16	4.2	42.5	42/49.5/47	00.00
USLKG 2.5N	0441119		24-21	5.2	42.5	42/49.5/47	
USLKG 3	0441083		24-12	5.2	42.5	47/54.5/52	
USLKG 5	0441504		24-12	6.2	42.5	47/54.5/52	
USLKG 6N	0442079		24-8	8.2	42.5	47/54.5/52	
USLKG 10N	3003923		20-6	...	76	10.2	42.5	47/54.5/52	
USLKG 16	0443023		12-4	...	101	12.2	42.5	54/61.5/59	
USLKG 35	0444019		18-0	...	150	15.2	50	62/69.5/67	
USLKG 50	0443049		6-0	...	150	20	70.5	-/83.5/81.5	
USLKG 95	0441041		4-000	...	232	25	83	-/99/95.5	

UNIVERSAL DOUBLE LEVEL TERMINAL BLOCKS

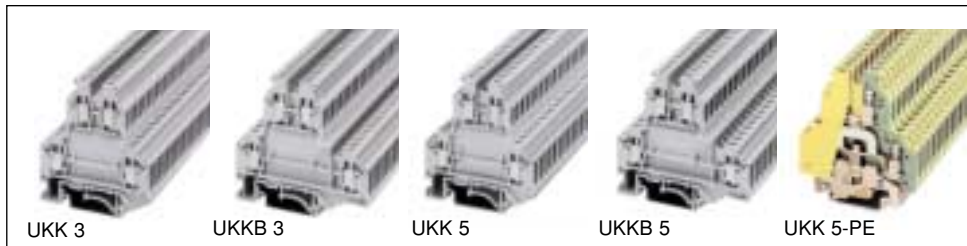

The UKK Double level Terminal blocks are available in two versions. the **UKKB** Types have bridge shafts in both levels and the **UKK** types can only be bridged in the upper level. type **UKK 5-PE** ground Terminal block is available for connecting ground conductors. These blocks have a universal base which which adapts to both NS 32 and NS 35 mounting rails. Color: Gray (blue available). Ground (PE) block is green/yellow. **Connections:** Screw clamps. **Flammability Rating:** UL94V0 (UL94V2 for UKK 5-PE). **Approvals:** UL recognized, CSA Certified.

European approvals available upon request. A full range of accessories are available (Order separately).

Mfr's Type	Order No.	Description	AWG	Rating		Dimensions (mm)			Each
				V	A*	W	L	H (NS 35: 7.5/NS 35:15/NS 32)	
UKK 3	2770011	Universal Double Level Terminal Block	24-12	500	32	5.2	56	62/69.5/67	00.00
UKKB 3	2771010			500	32	5.2	67		
UKK 5	2774017			500	32	6.2	56		
UKKB 5	2771146	Universal Double Level Ground Term Block	...	500	32	6.2	67		
UKK 5-PE	2774211			6.2	56		

Accessory Table

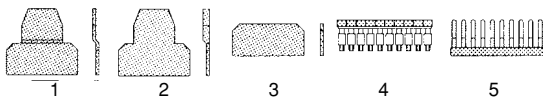

The accessories below are the two most common. A wider range of accessories are available (See "Accessories for Terminal Blocks"). Space covers and plates compensate for level offset if standard Terminal blocks are aligned.

Mfr's Type	Order No.	FIG	Description *	For Terminal Blocks	Each
D-UKK 3/5	2770024	1	End Cover, gray, 2.5mm wide	UKK 3, UKK 5	00.00
D-UKKB 3/5	2771023	1	End Cover, gray, 2.5mm wide	UKKB 3, UKKB 5	
DG-UKK 3/5	2770817	2	Spacer Cover, gray, 2.5mm thick	UKK 3, UKK 5	
DG-UKK 3/5	2770273	2	Spacer Cover, gray, 2.5mm thick	UKKB 3, UKKB5	
DP-UKK 3/5	2770794	3	Spacer Plate, gray, 2.5mm thick	UKK 3, UKK5	
DP-UKKB 3/5	2770804	3	Spacer Plate, gray, 2.5mm thick	UKKB 3, UKKB5	
FBRNI 10-5N	2770639	4	Fixed Bridge, 10-pos., breakable	UKK 3, UKKB 3	
FBI 10-6	0203250	4	Fixed Bridge, 10-pos., breakable	UKK 5, UKKB 5	
EBL 10-5	0303132	5	Insertion Bridge, 10-pos., Breakable	UKK 3, UKKB 3	
EB 10-6	0201139	5	Insertion Bridge, 10-pos., Breakable	UK 5, UKKB 5	
ZB 5	Marker Strips	UKK 3, UKKB3	
ZB 6	(Order, see "Acces. for Term. Blocks")	UK5, UKKB 5, UKK 5-PE	

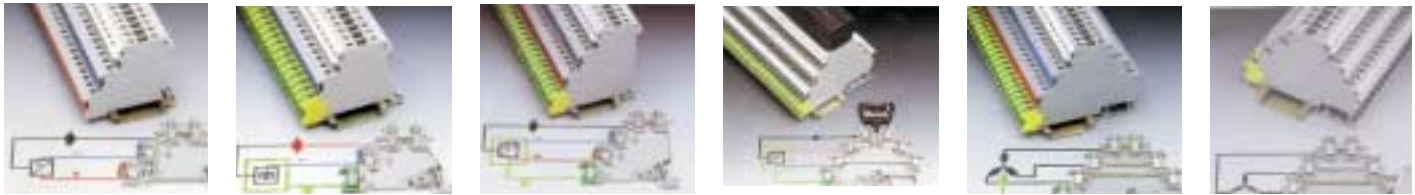

DIK 1.5

DOK 1.5

VIOK 1.5

VIOK 1.5-2D

VIOK 1.5-3D/PE

DLK 2.5-PE

The **DIK 1.5** 3-level sensor input block distributes a signal line (top level) as well as - and + potentials (middle and bottom levels) via insertion bridges. **DIKD 1.5** is the same, except with 3 feed-through contacts. **DOK 1.5** is a 3-level actuator output block which accommodates a signal line (top level) a bridged negative potential (middle level) and a grounding busbar (bottom level). **VIOK 1.5** is a 4-level combination of the DIK/DOK blocks where only one block is needed for sensors and actuators. This block distributes a signal line (top level), - and + supplies (middle levels) and grounding busbar (bottom level). **VIOK 1.2-2D** has a 2 feed-through and 2 busbar levels. **VIOK 1.5-3D/PE** is a 4-conductor feed-through block. The 3-conductor **DLK 2.5-PE** and **DLKB 2.5-PE** blocks are designed for 3-phase current. The DLKB is bridgeable via insertion bridges (bottom and middle levels) and fixed bridges (top level). **Color:** gray. **Connections:** screws. **Flammability rating:** UL94V2 (UL94V0 for DLK/DLKB blocks) **Approvals:** UL recognized CSA certified. Call for European approvals. **Mounting:** for NS 35 () rails only. A full range of accessories are available.

Mfr's Type	Order No.	Description	AWG	Rating		Dimensions (mm)			Each
				V	A*	W	L	H (NS 35:7.5/NS 35:15)	
DIK 1.5	2715966	8-lvl Sensor terminal block	24-12	250	26	6.2	55	54.5/62	00.00
DIKD 1.5	2715979	as above, but w/3 through contacts		250	24		72.5	54.5/62	
DOK 1.5	2717016	3-lvl. Actuator terminal block		250	26		61.5	54.5/62	
VIOK 1.5	2718015	4-lvl. Sensor/Actuator term. Block		250	26		62.5	70/77.5	
VIOK 1.5-2D	2718196	as above, but w/2 thru & 2 busbar levels		250	26		73	70/77.5	
VIOK 1.5-3D/PE	2718206	as above but w/4 feed thru levels		400*	26		82.5	70/77.5	
DLK 2.5-PE	3011041	4-lvl., 3- conductor terminal blocks		400	26		83	70/77.5	
DLKB 2.5-PE	3011038	as above, but bridgeable one side		400*	26		83.5	70/77.5	

*If EB insertion bridge is used, the nominal voltage is reduced to 250V.

Accessory Table for 3 and 4-Level Terminal Blocks

Mfr's Type	Order No.	Description	For Terminal Blocks	Each
FBI 10-6	0203250	Fixed Bridge, 10-pos., breakable	Fits all of the Term. Blocks above	00.00
EB 80-DIK BU	2715940	Insertion Bridge, 80-pos., breakable, blue,	Fits all except DLK 2.5 PE	
EB 80-DIK RD	2715953	Insertion Bridge, 80-pos., breakable, red	Fits all except DLK 2.5 PE	
EB 10-DIK GY	2715937	Insertion Bridge, 10-pos., breakable, gray	Fits all except DIK 1.5, DIKD 1.5, DLK 2.5-PE	
EB 10-DIK RD	2716774	Insertion Bridge, 10-pos., breakable, red	Fits all except DIK 1.5, DIKD 1.5, DLK 2.5-PE	
EB 10-DIK BU	2716680	Insertion Bridge, 10-pos., breakable, blue	Fits all except DIK 1.5, DIKD 1.5, DLK 2.5-PE	
ZB 6	...	Marker strips (order data, see "Accessories for Terminal Blocks")	Fits all of the Term. Blocks above	

Special Terminal Blocks/Special Connections



Twin Conductor Terminal Block UK...TWIN



Double Terminal Blocks UDK

The **UK... Twin** Terminal blocks solve the problem of "power distribution." They have two independent conductor connections on the load side, while on the input side they are the same shape as feed-thru universal terminal blocks UK 3N and UK 5N. The **UDK** versions feature power distribution using 2 terminal points on each connection side, as well as two bridging points in the terminal center. Both versions include ground terminal blocks in green-yellow closed housings. **Color:** gray (blue available). **Connections:** screws. **Flammability Rating:** UL94V2. **Mounting:** Universal. **Approvals:** Call.

Mfr's Type	Order No.	Description	AWG	Rating		Dimensions (mm)			Each
				V	A	W	L	H (NS 35:7.5/NS35:15/NS 32)	
UK 3-TWIN	3002225	Twin Conductor Term Block	24-14	400	24	5.2	50.5	7/54.5/52.5	00.00
UK 5-TWIN	1923021	Twin Conductor Term Block	24-12	500	32	6.2	50.5		
UK 3-TWIN-PE	1923128	Twin Conductor Ground Term Block	24-14	5.2	50.5		
UK 5-TWIN-PE	1923076	Twin Conductor Ground Term Block	24-12	6.2	50.5		
UDK 3	2775375	Double Term Block	24-12	500	32	5.2	63.5		
UDK 4	2775016	Double Term Block	24-12	690	32	6.2	63.5		
UDK 4-PE	2775184	Double Ground Term Block	24-12	6.2	63.5		

Note: Ground Blocks include white labels with ground symbols.

Accessory Table for 3 and 4-Level Terminal Blocks

Mfr's Type	Order No.	Description	For Terminal Blocks	Each
D-UK 5-TWIN	1923034	End Cover, Gray, 2mm wide	UK 3-TWIN, UK 5-TWIN	00.00
D-UDK 4	2775113	End Cover, Gray, 1.5mm wide	UDK 3, UDK 4	
FBI 10-5N	2770642	Fixed Bridge, 10-pos., breakable	UK 3-TWIN, UDK 3	
FBI 10-6	0203250	Fixed Bridge, 10-pos., breakable	UK 5-TWIN, UDK 4	
EBL 10-5	2303132	Insertion Bridge, 10-pos., breakable	UK 3-TWIN, UDK 3	
EB 10-6	0201139	Insertion Bridge, 10-pos., breakable	UK 5-TWIN, UDK 4	
ZB 5	...	Marker strip (order data, see "Accessories for Terminal Blocks")	UK 3-TWIN, UK3-TWIN-PE, UDK 3	
ZB 6	...		UK 5-TWIN, UK5-TWIN-PE, UDK 4, UDK 4-PE	

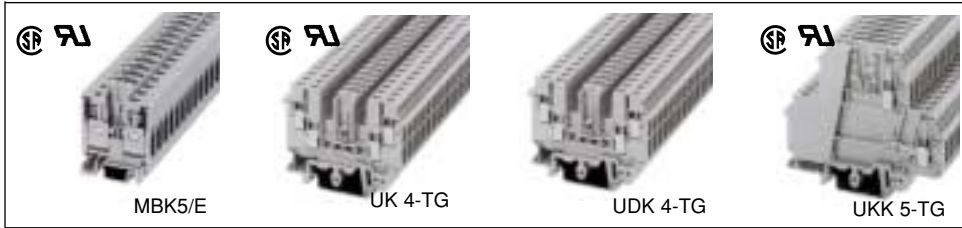

These fuse or component terminal blocks are base terminal blocks which accept the fuse or component plugs listed below. Because these **base** blocks have the same shape and dimensions as standard feed-through blocks **MBK5**, **UK5N**, **UDK4** and **UKKB5**, they can be combined with the standard blocks on one rail to perform various tasks. **Color:** Gray. **Connections:** Screw clamps. **Flammability Rating:** UL94V2. European approvals available. **Accessories** sold separately.

Mfr's Type	Order No.	Description	AWG	Rating		Dimensions (mm)			Each
				V†	A*	W	L	H(NS35:7.5/NS35:15/NS 32/NS15)	
MBK 5/E-TG	1415089	Base Terminal Block, Gray	24-12	500	16	6.2	28	-/-/36	00.00
UK 4-TG	2812018		24-12	500	16	6.2	42.5	47/54.5/52/-	
UDK 4-TG	2777014		24-12	690	16	6.2	63.5	47/54.5/52/-	
UKK 5-TG	3007042		24-12	400*	16*	6.2	80	68.5/76/73/-	

† Current & Voltage determined by component & fuse plugs *Upper level (lower level 400v, 26A) ** For std block UK 5N

Accessory Table

Mfr's Type	Order No.	Description *	For Terminal Blocks	Each
D-MBK 5/E-T	1413706	End Cover, Gray	MBK 5/E-TG UK 4-TG UDK 4-TG UKK 5-TG	00.00
P-UK 4/10	3003020			
D-UDK RELG	277027			
FBI 10-6	0203250	Fixed Bridge, 10-pos., breakable		
EB 10-6	0201139	Insertion Bridge, 10-pos., breakable	Fits all 4 base blocks	
ZB 6		Marker Strip (order data, see "Accessories for Terminal blocks")	UK 4-TG, UDK 4-TG, UKK 5-TG	

Fused and Component Plugs



Several plug versions are available for use with the base terminal blocks described above. The **ST-SI-UK 4** fuse plugs accommodate 5x20 mm fuse cartridges, and are available with or without a light indicator. The plug housing opens on one side to change the fuse. The **ST-BE** component plugs are available as single plugs for 2-position components and as double plugs for 4-position components with or without inserted components. The component itself is inserted and clamped at the top. The open design means that larger components can be used that protrude above the plug. All fuse and component plugs are coded to avoid polarity reversal. **Color:** Fuse plugs (black), component plugs (gray). **Flammability Rating:** fuse plugs (UL94V2), Component plugs (UL94V0).

Mfr's Type	Order No.	Description	Rating		Each
			V	A	
ST-SI-UK 4	0921011	Fuse plug for 5x20 mm fuses, 26.5mm high, color: black	300	6.3*	00.00
ST-SILED 24-UK 4	0921037	As above, except with 24v light indicator (15-30 v AC/DC)	300	6.3*	
ST-SILA 250-UK 4	0921053	As above, except with 250v light indicator (110-250v AC/DC)	300	6.3*	
ST-BE	2802316	Single component plug (for 2-position components), 19mm high, gray	-	-	
ST-BE-LA 24	2802374	As above, except with 24V DC LED	-	-	
ST-BE-LA 230	2802387	As above, except with 230v AC/DC LED	-	-	
ST-1N4007	2802329	As above, except with universal diode 1N4007	-	-	
ST-BE-VIERPOL	2802332	Double component plug (for 4 position components), 19mm high, gray	-	-	
ST-B250 C 1500	2802345	As above, except with bridge rectifier B 250 C 1500	-	-	

*UL (CSA 10A)

Component Terminal Block

This terminal block with integrated diode 1N4007 (conducting direction from top to bottom) is an alternative to using component plugs. It is the same size and shape as universal double level block UKK 5. **Color:** gray. **Connections:** screw clamps. **Flammability Rating:** UL94V2. **Mounting:** Universal. **Diode Reverse Voltage:** 1300 V; 1A max continuous current.

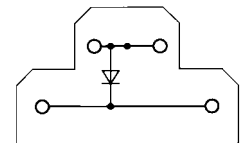

with diode from top to bottom

Mfr's Type	Order No.	Description	AWG	Rating		Dimensions (mm)			Each
				V†	A	W	L	H(NS35:7.5/NS35:15/NS 32)	
UKK 5-DIO/O-U	2791016	Term Block w/1N 4007 Diode, Gray	24-12	500	32	6.2	56	62/69.5/67	00.00

Accessories

Mfr's Type	Order No.	Description	Each
D-UKK 3/5	2770024	End cover, gray, 2.5 mm wide Spacer Cover, compensates for level offset if standard blocks are to be aligned Spacer plate, compensates for level offset if standard blocks are to be aligned, 2.5mm Th. Marker strip (order data, see "Accessories for terminal blocks")	00.00
DG-UKK 3/5	2770817		
DD-UKK 3/5	2770794		
ZB 6	...		

These slide link Test disconnect blocks are used extensively in the utilities industry. Each URTK/S-BEN block has a sliding link which enables the end user to employ a disconnect at the full rated value of the terminal. The connection screws have a socket cavity to accommodate 4mm Test plugs and 2 and 4-position short circuit plugs. The smaller URTL/SS block has the same features, but the connection screws are recessed with an opening which allows plugs to be inserted directly. Color: gray. mounting: Universal for plugs on either NS35 or NS 32 DIN rails. Flammability rating: URTK/S-BEN (UL94V0), URTK/SS (UL94V2).

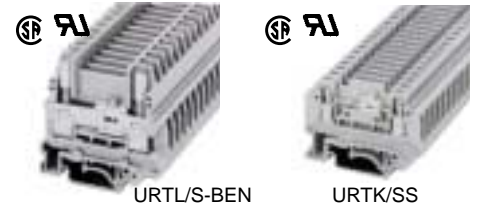

Mfr's Type	Order No.	Description	AWG	Rating		Dimensions (mm)				Each
				V†	A*	W	L	H(NS35:7.5/NS35:15/NS 32)		
URTK/S-BEN URTK/SS	0309086 0321019	Slide Link Disconnect term. Block	20-8 24-12	500 400	57 26	8.2 6.2	61 56.5	58.5/66/63.5 40/47.5/45		00.00

Accessories

Mfr's Type	Order No.	Description *	For Terminal Blocks	Each
D-UTK/S-BEN D-URTK/SS	0308029 0321022	End Cover, Gray, 2.2mm wide End Cover, Gray, 1mm wide	URTK/S-BEN URTK/SS	00.00
FBRNI 10-6 N	2770626	Fixed Bridge, 10-Pos., Breakable	URTK/SS	
EB 10-8 S	0202138 0308359	Insertion Bridge, 10-Pos., Breakable Switch lock (prevents operation of slide link)	URTK/S-BEN URTK/S-BEN	
KSS-8 KSS 4-8 KSS-6 KSS 3-6	0311540 0309549 0301547 0309523	Short Circuit Plug 2-pos. 4-pos. 2-pos. 3-pos.	URTK/S-BEN URTK/S-BEN URTK/SS URTK/SS	
ZB6 ZB8	Marker Strip (order data, see "Accessories for terminal Blocks")	URTK/SS URTK/S-BEN	

KNIFE DISCONNECT TERMINAL BLOCKS



Knife disconnect blocks permit rapid fault isolation and insertion under zero volt conditions. They feature space saving construction and high current carrying capacity. P/P types have test Socket Screws (to accommodate 4mm test Plugs) in lieu of standard screw connections. UDK4-MTK-P/P has double connection points to accommodate several wires on each module. Color: Gray (knife disconnects orange). Flammability Rating: UL92V2. Mounting: Universal. Approvals: UL Recognized, CSA Certified.

Mfr's Type	Order No.	Description	AWG	Rating		Dimensions (mm)				Each
				V	A	W	L	H (NS35:7.5/NS35:15/NS 32)		
MTK-P/P MTK MTKD-P/P MTKD UK 5-MTK-P/P UDK 4-MTK-P/P UKK 5-MTK-P/P UKK 5-MTKD-P/P	3104013 3101016 3100020 3100017 3004032 2775210 2800004 2800017	Knife Disconnect Term. Block w/socket screws As above, except w/standard screws Feed-thru Block (w/o knife), w/socket screws As above, except w/standard screws Knife Disconnect Term. Block w/socket screws As above, w/double connections points Dbl. Lvl. knife Disconnect upper Lvl. socket screws Dbl. Lvl. Feed-thru (w/o knife), w/socket screws	24-12	400 400 400 400 800 690 400 400	16 16 16 16 16 16 12* 12*	5.2 5.2 5.2 5.2 6.2 6.3 6.2 6.2	46 46 46 46 51 63.5 80 80	51.5/59/56 51.5/59/56 51.5/59/56 51.5/59/56 58.5/66/63.5 47/54.5/52 68/76/73 68/76/73		00.00

* Upper level (lower level 26A) NOTE: Types UK5... and UKK5... have enclosed houses

Accessories

Mfr's Type	Order No.	Description	For Terminal Blocks	Each
D-MTK D-UDK4	3101029 2775113	End Cover, Gray 1mm wide End Cover, Gray, 1.5mm wide	MTK-P/P, MTK, MTKD-P/P, MTKD UDK 4-MTK-P/P	00.00
FBI 10-6	0203250	Fixed Bridge, 10Pos., Breakable	UKK 5-MTK-P/P, UKK 5-MTKD-P/P	
EBL 10-5 EB 10-6	2003132 0201139	Insertion Bridge, 10-Pos., Breakable Insertion Bridge, 10-Pos., Breakable	MTK-P, MTK, MTKD-P/P, MTKD UK 5-MTK-P/P, UDK 4-MTK-P/P	
ATS-MTK	3101223	Partition Plate, for electrical separation of Terminal Groups	MTK-P/P, MTK, MTKD-P/P, MTKD	
ATP-UK 5-MTK	3004210	Partition Plate, for electrical separation of Terminal Groups	UK 5-MTK-P/P	
ZB 5 ZB 6	Marker Strips (order data, see "Accessories for Terminal Blocks")	MTK-P/P, MTK, MTKD-P/P, MTKD UK 5-MTK-P/P, UDK 4-MTK-P/P, UKK 5-MTK-P/P UKK 5-MTKD-P/P	

Equipment Terminal Blocks

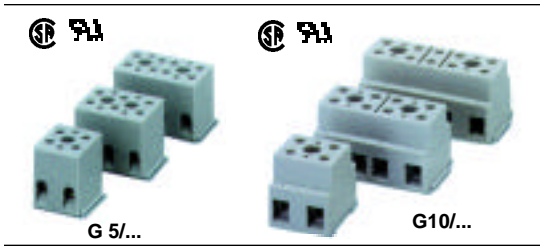

These compact direct mounted terminal blocks are used primarily with network connections for electrical and electronic equipment and small terminal boxes. **G5** blocks accommodate wires up to 12 AWG and **G10** blocks are for wires up to 8 AWG (stranded) and 6 AWG (solid). The housing is made of shock proof UL94V2 impact resistant plastic. The blocks interlock and are supplied with two screws each for mounting. Connection points can be labeled with optional marker pins which insert into notches in the top of each block. **Color:** Gray.

Mfr.'s Type	Order No.	Description	AWG	Rating		Dimensions (mm)			Each
				V	A	W	L	H	
G 5/2	2716020	Equipment Term. Block	24-12	500	32	22	20	24	1.84
G 5/3	2716033								2.63
G 5/4	2716046								3.35
G 5/6	2716062								4.77
G 5/12	2716127								9.04
G 10/2	2716703	Equipment Term. Block	20-6	750*	76	33	29	31	4.89
G10/3	2716716								7.35
G10/4	2716729								9.80
G 10/5	2716732								12.24

*DIN VDE 0606(800V IEC 947-7-1)

Accessories

Marker pins are available either in white/unprinted for labeling with a marker pen or white/printed with 1, 2 or 3 characters (must specify characters when ordering).

Mfr.'s Type	Order No.	Description	Each
BN WH	1401404	Marker pin, unprinted for labeling with a marker pen, white, area 4x4 mm	0.08
BNB WH:... *	1401417	As above, except printed with 1, 2, or 3 characters, white, area 4x4 mm	0.02
BN-AS WH	1401420	Group cover marker, unprinted, white, area: 4x20.5 mm	0.18
WS-G 5/2	2720029	Warning plate, completely covers terminal surface	For G 5/2 0.32
WS-G 5/3	2720032		For G 5/3 0.35
WS-G 5/4	2716499		For G 5/4 0.36
B-STIFT	1051993	Marker pen for labeling unprinted markers. Smear-proof and waterproof.	call

*Specify marking when ordering.

1/N/PE Connecting Terminal Blocks

Neutral (N), ground (PE) or phase conductors (L) are often connected to central busbars and require clear marking of the terminal blocks to the corresponding circuit. The **AKG** connecting terminal blocks fulfill this requirement with their blue, green-yellow or black housings. They fit onto 3x10 mm busbars with a captive pressure plate and non-loosening screws. Three supports made of insulating material are available to hold the busbars: a single bar support and two offset double bar supports (one 48mm high, the other only 36.8 mm high). **Flammability Rating:** UL94V2. **Approvals:** ULRecognized, CSACertified (AKG 16 only).



Mfr.'s Type	Order No.	Description	AWG	A	Dimensions (mm)			Each
					W	L	H*	
AK 4	0404017	L/N/PE Connecting term block w/o insulating cap	20-10	41	7	23.5	35.5	0.46
AKG 4BU	0421016	As above, except w/ blue insulating cap (for N)						0.63
AKG 4 CNYE	0421029	As above, except w/ green-yellow insulating cap (for PE)						0.63
AKG 4 BK	0421032	As above, except w/ black insulating cap (for L1,L2,L3)						0.63
AK 16	0404033	L/N/PE connecting term block w/o insulating cap	16-6	76	10	23.5	44.5	0.68
AKG 16 BU	0423014	As above, except w/ blue insulating cap (for N)						0.92
AKG 16 GNYE	0423027	As above, except w/ green-yellow insulating cap (for PE)						0.92
AKG 16 BK	0423030	As above, except w/black insulating cap (for L1,L2,L3)						0.92

* Height above mounting surface.

Accessories

Mfr.'s Type	Order No.	Description	Each
NLS-CU 3/10	0402174	Neutral Busbar, 3x10 mm, length: 1m, copper tin-plated, 140 A max.	11.45
AB/SS	0404428	Support, single bar, insulated, w/retaining screw, for 3x10 mm or 6x6 mm busbars	1.03
AB 2/SS	0404431	Support, offset double bar, insulated, for 3x10 mm or 6x6 mm busbars, 48 mm high	1.69
ABN 2/SS	0404460	Support, offset double bar, insulated, for 3x10 mm or 6x6 mm busbars, 36.8 mm high	1.69
ZB 6	...	Marker strip for AK 4 series (order data, see "Accessories for Terminal Blocks").	0.91
ZB 8	...	Marker strip for AK 16 Series (order data, see "Accessories for Terminal Blocks")	0.91

A complementary option to screw terminal block technology is spring cage technology where a spring pulls the conductor tight against the current bar. The pre-stressed corrosion-proof copper alloy spring is opened using a screwdriver so the conductor can be inserted into the insertion space through an opening in the spring leg. The conductor is pulled against the current bar under spring force when the screwdriver is removed.

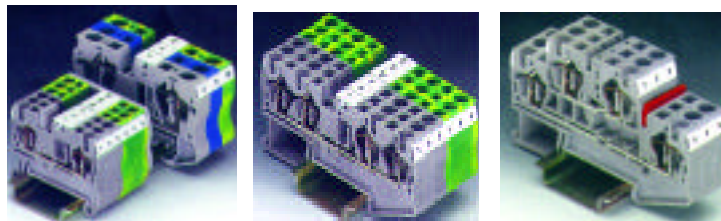

ST Series

Feed-through terminal blocks ST Multi-conductor spring cage terminal blocks Spring cage double level terminal blocks

Phoenix Contact announces the introduction of a new high density spring cage terminal block family (ST). The new "mini spring" design reduces the overall size of the terminal block without giving up any features. The ST product has a flexible dual channel push-in jumper system, which can handle and chain bridging using 2, 3, 4, 5, 10 or 20 position jumpers. There is a generous wire entrance which eliminates the need to use a larger terminal block when ferrules are used. The ST block has large center marking for easy access and readability and end marking for labeling each termination point. The housings are made of unbreakable polyamide 6.6. **Color:** gray (-PE models green-yellow), **Connections:** spring cage. **Flammability Rating:** UL94V0. **Mounting:** EN50022 (NS35) rails.

Spring Cage Feed Through Terminal Blocks

Mfr.'s Type	Order No.	Description	AWG	Rating		Dimensions (mm)				Each
				V	A	W	L	H (NS35:7.5/NS35:15)		
ST 1.5	3031076	Spring cage feed-through terminal, gray	26-14	300	15	4.2	48.5	36.5/44		0.86
ST 1.5-PE	3031513	Spring cage ground terminal block, gn/ye	26-14	4.2	48.5	36.5/44		2.87
ST 2.5	3031212	Spring cage feed-through terminal, gray	26-12	600	20	5.2	48.5	36.5/44		0.95
ST 2.5-PE	3031238	Spring cage ground terminal block, gn/ye	26-12	5.2	48.5	36.5/44		3.40
ST 4	3031364	Spring cage feed-through terminal, gray	24-10	600	30	6.2	56	36.5/44		1.12
ST 4-PE	3031380	Spring cage ground terminal block, gn/ye	24-10	6.2	56	36.5/44		3.42
ST 6	3031487	Spring cage feed-through terminal, gray	20-8	600	50	8.2	65.5	43.5/51		1.67
ST 6-PE	3031500	Spring cage ground terminal block, gn/ye	20-8	8.2	65.5	43.5/51		4.28

Multi-Conductor Spring Cage Terminals Blocks

Mfr.'s Type	Order No.	Description	AWG	Rating		Dimensions (mm)				Each
				V	A	W	L	H (NS35:7.5/NS35:15)		
ST 1.5-Twin	3031128	Three-conductor spring cage feed through terminal, gray	26-14	300	15	4.2	60.5	36.5/44		0.93
ST 1.5-Twin-PE	3031144	Three-conductor spring cage ground terminal block, gn/ye	26-14	4.2	60.5	36.5/44		3.58
ST 2.5-Twin	3031241	Three-conductor spring cage feed through terminal, gray	26-12	600	20	5.2	60.5	36.5/44		1.10
ST 2.5-Twin-PE	3031267	Three-conductor spring cage ground terminal block, gn/ye	26-12	5.2	60.5	36.5/44		3.87
ST 4-Twin	3031393	Three-conductor spring cage feed through terminal, gray	24-10	600	30	6.2	71.5	36.5/44		1.17
ST 4-Twin-PE	3031416	Three-conductor spring cage ground terminal block, gn/ye	24-10	6.2	71.5	36.5/44		4.03
ST 1.5-Quattro	3031186	Four-conductor spring cage feed through terminal, gray	26-14	300	15	4.2	72	36.5/44		1.09
ST 1.5-Quattro-PE	3031209	Four-conductor spring cage ground terminal block, gn/ye	26-14	4.2	72	36.5/44		3.80
ST 2.5-Quattro	3031306	Four-conductor spring cage feed through terminal, gray	26-12	600	20	5.2	72	36.5/44		1.58
ST 2.5-Quattro-PE	3031322	Four-conductor spring cage ground terminal block, gn/ye	26-12	5.2	72	36.5/44		5.03
ST 4-Quattro	3031445	Four-conductor spring cage feed through terminal, gray	24-10	600	30	6.2	87	36.5/44		1.96
ST 4-Quattro-PE	3031461	Four-conductor spring cage ground terminal block, gn/ye	24-10	6.2	87	36.5/44		5.09

Double Level Spring Cage Terminals Blocks

Mfr.'s Type	Order No.	Description	AWG	Rating		Dimensions (mm)				Each
				V	A	W	L	H (NS35:7.5/NS35:15)		
STTB 1.5	3031157	Double level spring cage feed through terminal, gray	26-14	300	15	4.2	67.5	47.5/55		1.47
STTB 2.5	3031270	Double level spring cage feed through terminal, gray	26-12	600	20	5.2	67.5	47.5/55		2.24
STTB 4	3031429	Double level spring cage feed through terminal, gray	24-10	600	30	6.2	83.5	47.5/55		2.36
MZFFKB 1.5	3005714	Mini double level spring cage feed through terminal, gray	26-14	600	15	5.2	85	42/42.5		2.71

Accessories for ST Series Spring Cage Terminal Blocks are on the next page

Accessories for ST Series Spring Cage Terminal Blocks (ST Series terminal blocks are on the previous page)

Mfr.'s Type	Order No.	Description	For Terminal Blocks	Amperage	Each
D-ST 2.5	3030417	End cover gray, 2mm wide	ST2.5	...	0.46
D-ST 4	3030420	End cover gray, 2mm wide	ST 4	...	0.49
D-ST 6	3030433	End cover gray, 2mm wide	ST 6	...	0.49
D-ST 2.5-Twin	3030488	End cover gray, 2mm wide	ST2.5-Twin	...	0.47
D-ST 4-Twin	3030491	End cover gray, 2mm wide	ST 4-Twin	...	0.48
D-ST 2.5-Quattro	3030514	End cover gray, 2mm wide	ST2.5-Quattro	...	0.49
D-ST 4-Quattro	3030527	End cover gray, 2mm wide	ST4-Quattro	...	0.49
D-STTB 2.5	3030459	End cover gray, 2mm wide	STTB 2.5	...	0.51
D-STTB 4	3030462	End cover gray, 2mm wide	STTB 4	...	0.52
FBS 2-4	3030116	Plug-in bridge 2 position	ST1.5	17.5	0.40
FBS 3-4	3030129	Plug-in bridge 3 position	ST1.5	17.5	0.80
FBS 4-4	3030132	Plug-in bridge 4 position	ST1.5	17.5	1.25
FBS 5-4	3030145	Plug-in bridge 5 position	ST 1.5	17.5	1.55
FBS 10-4	3030158	Plug-in bridge 10 position	ST 1.5	17.5	3.25
FBS 20-4	3030352	Plug-in bridge 20 position	ST 1.5	17.5	Call
FBS 2-5	3030161	Plug-in bridge 2 position	ST 2.5	24	0.40
FBS 3-5	3030174	Plug-in bridge 3 position	ST 2.5	24	0.80
FBS 4-5	3030187	Plug-in bridge 4 position	ST 2.5	24	1.25
FBS 5-5	3030190	Plug-in bridge 5 position	ST 2.5	24	1.55
FBS 10-5	3030213	Plug-in bridge 10 position	ST 2.5	24	3.25
FBS 20-5	3030226	Plug-in bridge 20 position	ST 2.5	24	6.50
FBS 2-6	3030336	Plug-in bridge 2 position	ST 4	32	0.40
FBS 3-6	3030242	Plug-in bridge 3 position	ST 4	32	0.80
FBS 4-6	3030255	Plug-in bridge 4 position	ST 4	32	1.25
FBS 5-6	3030349	Plug-in bridge 5 position	ST 4	32	1.55
FBS 10-6	3030271	Plug-in bridge 10 position	ST 4	32	3.25
FBS 20-6	3030365	Plug-in bridge 20 position	ST 4	32	6.50
FBS 2-8	3030284	Plug-in bridge 2 position	ST 6	41	0.50
FBS 3-8	3030297	Plug-in bridge 3 position	ST 6	41	1.05
FBS 4-8	3030307	Plug-in bridge 4 position	ST 6	41	1.70
FBS 5-8	3030310	Plug-in bridge 5 position	ST 6	41	2.10
FBS 10-8	3030323	Plug-in bridge 10 position	ST 6	41	4.25
ATP-ST 4	3030721	Partition plate for separation of groups 2mm thick	ST 1.5, 2.5, 4, 6	...	0.43
ATP4-Twin	3030789	Partition plate for separation of groups 2mm thick	ST 1.5, 2.5, 4 Twin	...	0.57
ATP4-Quattro	3030815	Partition plate for separation of groups 2mm thick	ST 1.5, 2.5, 4 Quattro	...	0.61
ATP-STTB 4	3030747	Partition plate for separation of groups 2mm thick	ST1.5, 2.5, 4 STTB	...	0.61
ZBFM 4	*	Marker sheets, flat for labeling outer grooves	ST 1.5 all series	...	8.55
ZBFM 5	*	Marker sheets, flat for labeling outer grooves	ST 2.5 all series	...	8.55
ZBFM 6	*	Marker sheets, flat for labeling outer grooves	ST4 all series	...	8.55
ZBFM 8	*	Marker sheets, flat for labeling outer grooves	ST 6	...	8.55
ZB 4	*	Marker strip for center of terminal and plug in bridges	ST 1.5 all series	...	0.91
ZB 5	*	Marker strip for center of terminal and plug in bridges	ST2.5 all series	...	0.91
ZB 6	*	Marker strip for center of terminal and plug in bridges	ST 6	...	0.91

* Order data, see "Accessories for Terminal Blocks"

Spring Cage Knife Disconnect Terminal Blocks

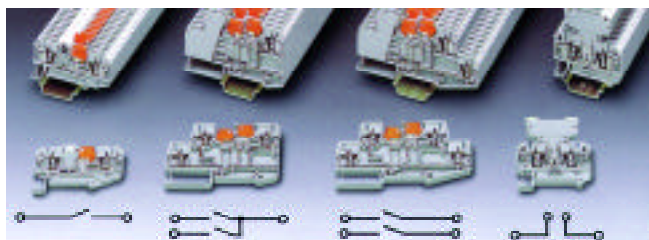

ZFK 2.5-MT ZDMTK 2.5-TWIN ZDMTK 2.5 ZFK 4-TG

These feed-through knife disconnect terminal blocks with 2.3 mm test plugs permit rapid fault isolation and inspection of work under zero volt conditions. Models **ZFK 2.5-MT** and **ZFDK 2.5-MT** (not shown) are single level blocks with one and two disconnectable feed-through circuits respectively. Models **ZFKK 2.5-MT** (not shown) and **ZDMTK 2.5** are double level blocks: **ZFKK 2.5-MT** disconnects only in the top level and **ZDMTK 2.5** on both levels. **ZDMTK 2.5-TWIN** has one input circuit and two disconnectable output circuits. **Model ZFK 4-TG** is a fuse or component base terminal block which accepts the ST-SI...fuse plugs and ST-BE component plugs shown on a previous page. **Color:** gray (orange disconnects). **Flammability Rating:** UL94V0. **Mounting:** NS 35 rails.

Approvals: (ZFDK 2.5-MT, ZFK 4-TG); (ZFK 2.5-MT)

Mfr.'s Type	Order No.	Description	AWG	Rating		Dimensions (mm)			Each
				V	A	W	L	H (NS 35:7.5/NS 35:15)	
ZFK 2.5-MT	3001873	Knife disconnect terminal block: 1-current	24-12	400	16*	5.2	71	37.5/45	3.62
ZFDK 2.5-MT	3025053	As above, except with 2-circuits				5.2	88.5	37.5/45	4.53
ZFKK 2.5-MT	3025011	Dbl.level term. blk. W/top disconnect				5.2	104	49/56.5	4.22
ZDMTK 2.5	3005798	As above, w/both levels disconnecting				6.2	107	55/62.5	13.27
ZDMTK 2.5-TWIN	3005808	1-input, 2-disconnectable outputs	20-10			6.2	88.5	55/62.5	13.35
ZFK 4-TG	3001857	Base term.blk for fuse/component plugs				6.2	58.5	40.5/48	2.17

*ZFKK 2.5-MT upper level 16 A, lower level 26 A

Accessories

Mfr.'s Type	Order No.	Description	For Terminal Blocks	Each
D-ZFK 2.5-TWIN	3002801	End cover, gray, 2 mm wide	ZFK 2.5-MT	0.55
D-ZFKD 2.5-MT	3024216		ZFDK 2.5-MT	0.57
D-ZFKK 2.5-MT	3024151		ZFKK 2.5-MT	0.59
D-ZFK 4	3002791		ZFK 4-TG	0.54
FBRI 10-5N	2770642	Fixed Bridge, 10 Position, Breakable	ZFK 2.5-MT, ZFKK 2.5-MT	5.52
FBSTB 2-5	3024643	Plug-in bridge for term.center, 2-pos.	ZFK 2.5-MT, ZFKK 2.5-MT	0.62
FBSTB 3-5	3024656	can be labeled 3-pos.	ZFK 2.5-MT, ZFKK 2.5-MT	1.15
FBSTB 10-5	3024724	10-pos.	ZFK 2.5-MT, ZFKK 2.5-MT	4.55
ATP-ZFKKB 4	3005772	Partition plate, for separation of terminal block groups, 2 mm thick	ZDMTK 2.5, ZDMTK 2.5-TWIN	0.55
ZBFM 5	...	Marker sheets, flat, for labeling outer grooves (order data, see "Accessories for Terminal Blocks")	ZFK 2.5-MT, ZFDK 2.5-MT, ZFKK 2.5-MT	8.55
ZBFM 6	...		ZDMTK 2.5, ZDMTK 2.5-TWIN, ZFK 4-TG	8.55
ZB 5	...	Marker strips for term. center & plug-in bridges (order data, see "Accessories for Terminal Blocks")	ZFK 2.5-MT, ZFDK 2.5-MT, ZFKK 2.5-MT	0.91

Spring Cage Initiator/Actuator Terminal Blocks

The **ZDIK** wires 3-conductor initiators on 3-levels. The lower level can be used to connect the + or ground potentials and the middle level connects the - potential. Once power is fed in, it is distributed in the lower and middle levels via color-coded plug-in bridges, which can also be labeled. The upper level is used to loop in the signal lines and can be interconnected using a screw bridge (FBRI) or a plug-in bridge (FBSTB). The **ZVIOK** is a 4-level block. It uses the lower level for grounding, the middle levels for + and - supply, and the upper level for the signal lines. **Color:** gray. **Flammability Rating:** UL94V0. **Mounting:** NS 35 rails.



Mfr.'s Type	Order No.	Description	AWG	Rating		Dimensions (mm)			Each
				V	A	W	L	H (NS 35:7.5/NS 35:15)	
ZDIK 1.5	3006470	3-lvl. Initiator/Actuator term. block	26-14	250	17.5	5.2	73.5	48.5/56.5	3.18
ZVIOK 1.5	3006506	4-lvl. Initiator/Actuator term. block	26-14	250	17.5	5.2	90	48.5/56.5	4.09

Accessories

Mfr.'s Type	Order No.	Description	For Terminal Blocks	Each
D-ZDIK 1.5	3006593	End cover, gray, 2 mm wide	ZDIK 1.5	0.88
D-ZVIOK 1.5	3006603	End cover, gray, 1 mm wide	ZVIOK 1.5	0.93
FBRI 10-5N	2770642	Fixed bridge, 10-pos., breakable	ZDIK 1.5, ZVIOK 1.5	5.50
FBST 2-5	3025066	Plug-in bridge for term.center, can 2-pos.	ZDIK 1.5, ZVIOK 1.5	0.59
FBST 3-5	3025079	be labeled 3-pos.		1.10
FBST 10-5	3025147	10-pos.		4.35
FBSTB 10-ZDIK GY	3006535	Plug-in bridge, color-coded gray	ZDIK 1.5, ZVIOK 1.5	1.77
FBSTB 10-ZDIK RD	3006551	red		1.77
FBSTB 10-ZDIK BU	3006548	blue		1.77
FBSTB 10-ZDIK GNYE	3006771	green-yellow		1.77
ZBFM 5	...	Marker sheet, flat, for labeling outer grooves (order data, see "Accessories for Terminal Blocks")	ZDIK 1.5, ZVIOK 1.5	8.55
ZB 5	...	Marker strips for term. center & plug-in bridges (order data, see "Accessories for Terminal Blocks")	ZDIK 1.5, ZVIOK 1.5	.91

1752

Benjamin Franklin is the first to define positive and negative electrical charges. Lacking terminology, he invents new words such as positive, negative, battery, condenser, charge, discharge, electrical shock, electrician, armature, brush and conductor.

Spring Cage Fuse Terminal Blocks with Disconnect Lever



ZFK 4-HESI (5 X 20) ZDK 4-HESI (6.3 X 32)

Spring cage fuse terminal blocks from Phoenix Contact satisfy two important basic tasks of connection systems. First, they hold fuses and secondly, they take on the task of power distribution using fixed bridges. Each block features a hinged disconnect lever for quick and safe fuse exchanges. These terminal blocks are available for either 5 x 20 or 6.3 x 32 mm fuses, and a light indicator option which glows when the fuse is blown. **Color:** black. **Flammability Rating:** UL94V0. **Mounting:** NS 35 rails.

Mfr.'s Type	Order No.	Description	AWG	Rating		Dimensions (mm)			Each
				V *	A*	W	L	H (NS 35:7.5/NS 35:15)	
ZFK 4-HESI (5 X 20)	3025451	Fuse term. block for 5 x 20 mm fuses	20-10	400	6.3	8.2	82	65.5/73	5.72
ZFK 4-HESILED24 (5 X 20)	3025367	As above, except w/24 V light indicator							14.61
ZFK 4-HESILA250 (5 X 20)	3025370	As above, except with 250 V light indicator							14.10
ZFK 4-HESI (6.3 X 32)	3025464	Fuse term. block for 6.3 x 32 fuses	20-10	400	6.3	8.2	82	65.5/73	6.75
ZFK 4-HESILED24 (6.3 X 32)	3025383	As above, except w/24 V light indicator							16.49
ZFK 4-HESIL250 (6.3 X 32)	3025396	As above, except w/250 V light indicator							15.19

*The current is determined by the fuse; the voltage by the light indicator

Accessories

Mfr.'s Type	Order No.	Description	For Terminal Blocks	Each
ZBFM 8	...	Marker sheet, flat, for labeling marker grooves (order data, see "Accessories for Terminal Blocks")	Fits all the terminal blocks above	8.55

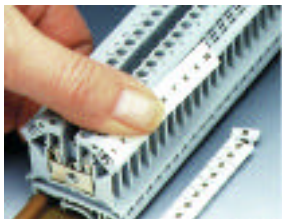

Accessories For Terminal Blocks

Zack ("Quick") Marking Strips

Each **ZB** marker strip consists of 10 white tear-apart markers which are pushed into the label grooves of the terminal blocks. Three versions are listed below - unprinted (for use with a marking pen) and consecutive numbers labeled horizontally or vertically. Other available options include colored markers, decade labeling (10, 20, 30 - 100), identical numbers, larger 100 piece sections and custom printing. Call for details on these and other options.

Mfr.'s Type	Order No.	For Term. Width	Description	Per Strip
ZB 4: unprinted	0805001	4.2 mm	10 pc. marker strip, unprinted	0.91
ZB 4, LGS: 1-10	0805739		10-pc. marker strip, labeled horizontally, w/consecutive numbers 1-10, etc. (specify*)	0.91
ZB 4, QR: 1-10	0805807		As above, except labeled vertically	0.91
ZB 5: unprinted	1050004	5.2 mm	10 pc. marker strip, unprinted	0.91
ZB 5, LGS: 1-10	1050017		10-pc. marker strip, labeled horizontally, w/consecutive numbers 1-10, etc. (specify*)	0.91
ZB 5, QR: 1-10	1050020		As above, except labeled vertically	0.91
ZB 6: unprinted	1051003	6.2 mm	10 pc. marker strip, unprinted	0.91
ZB 6, LGS: 1-10	1051016		10-pc. marker strip, labeled horizontally, w/consecutive numbers 1-10, etc. (specify*)	0.91
ZB 6, QR: 1-10	1051029		As above, except labeled vertically	0.91
ZB 8: unprinted	1052002	8.2 mm	10 pc. marker strip, unprinted	0.91
ZB 8, LGS: 1-10	1052015		10-pc. marker strip, labeled horizontally, w/consecutive numbers 1-10, etc. (specify*)	0.91
ZB 8, QR: 1-10	1052028		As above, except labeled vertically	0.91
ZB 10: unprinted	1053001	10.2 mm	10 pc. marker strip, unprinted	0.91
ZB 10, LGS: 1-10	1053014		10-pc. marker strip, labeled horizontally, w/consecutive numbers 1-10, etc. (specify*)	0.91
ZB 10, QR: 1-10	1053027		As above, except labeled vertically	0.91

* Specify consecutive numbers. For example: ZB 4, LGS: 1-10 (or ZB 4, QR: 1-10) ZB 4 ZB 4, LGS: 1-20 etc. up to ZB 4, LGS: 991-1000



Zack ("Quick") Marking Sheets

Each **ZBFM** marker sheet consists of 50, 100 or 120 white tear-apart markers for marking terminal blocks and smaller modules with marker grooves. Three versions are listed below: unprinted for use with a marking pen: with consecutive numbers (1-50, 1-100 or 1-120) labeled horizontally: and with 10 identical strips of consecutive numbers (ie 1-10, 11-20, etc.). Special marker sheets are also available per customer specifications. Call for details.

Mfr.'s Type	Order No.	For Term. Width	Description	Per Sheet
ZBFM 4/WH: UNPRINTED	0803579	4.2 mm	100-pc. marker sheet, unprinted	8.55
ZBFM 4/WH, LGS: 1-100	0800268		100-pc. marker sheet, labeled horizontally w/consecutive number 1-100	8.55
ZBFM 4/WH, LGS: 1-10	0803582		As above, except w/10 identical strips of consecutive numbers 1-10, etc. Specify ❶	8.55
ZBFM 5/WH: UNPRINTED	0803595	5.2 mm	120-pc. marker sheet, unprinted	8.55
ZBFM 5/WH, LGS: 1-120	0800271		120-pc. marker sheet, labeled horizontally, w/consecutive numbers 1-120	8.55
ZBFM 5/WH, LGS: 1-12	0803605		As above, except w/10 identical strips of consecutive numbers 1-12, etc. Specify ❷	8.55
ZBFM 6/WH: UNPRINTED	0803618	6.2 mm	100-pc. marker sheet, unprinted	8.55
ZBFM 6/WH, LGS: 1-100	0800284		100-pc. marker sheet labeled horizontally w/consecutive numbers 1-100	8.55
ZBFM 6/WH, LGS: 1-10	0803621		As above, except w/10 identical strips of consecutive numbers 1-10, etc. Specify ❶	8.55
ZBFM 8/WH: UNPRINTED	0800734	8.2 mm	50-pc. marker sheet, unprinted	8.55
ZBFM 8/WH, LGS: 1-50	0804918		50-pc. marker sheet, labeled horizontally w/consecutive numbers 1-50	8.55
ZBFM 8/WH, LGS: 1-5	0804921		As above, except w/10 identical strips of consecutive numbers 1-5, etc. Specify ❶	8.55

❶ ZBFM 4/ or 6/WH, LGS: 1-10, 11-20, etc. up to 91-100.

❷ ZBFM 5/WH, LGS: 1-12, 13-24, etc. up to 109-120.

❸ ZBFM 8/WH, LGS: 1-5, 6-10, etc. up to 46-50.

Marker Pens



For manually labeling unprinted marker strips and sheets. Smear-proof and waterproof. Black

Mfr.'s Type	Order No.	Tip Size	Each
M-PEN	1051993	0.5 mm	9.03
M-PEN 0-8	1051728	0.8 mm	9.03

Partition Plates

ATP partition plates extend on all sides above the terminal profile for a clear visual and electrical separation of terminal block groups.



Mfr.'s Type	Order No.	Fits Block	Each
TP-UK 35	3008096	UK35	0.89
ATP-UK	3003224	UK1.5, UK2.5N, UK3N, UK5N, UK6N, UK10N, UK16N, UK4-TG	0.72
ATP-UKK 3/5	2778521	UKK3, UKK5	1.08
ATP-UKKB 3	2771065	UKKB3, UKKB5	1.11
ATP-DIK 1.5	1413272	DIK1.5	0.91
ATP-DIKD 1.5	1413285	DIKD1.5, DOK1.5	1.02
ATS-MBK	1413227	MBK3/E-Z, MBK6/E, MBK5/E	0.76
ATS-ATK-BEN	0308223	URTK/S-BEN	1.45
ATP-URTK/SS	0321226	URTK/SS	0.54

TS Separating Plates



These plates guarantee electric and visual isolation in the cases of bridges in the terminal center which are in direct contact with one another. It's designed to be inserted later and snap locks into place. A separation plate should be used on both sides for all bridges in the terminal center.

Mfr.'s Type	Order No.	Fits Block	Each
TS-KK 3	2770215	UK2.5N, UKK3, UKKB3, UKK5, UKKB5, UDK3, UDK4, MBK3/E-7, MBK6/E, MBK5/E, MBKKB2.5, MZFKKB1.5, ZDIK1.5, ZVIOK1.5	0.17
TS-K	1302215	UK3N, UK5N, UK6N, UK10N, UK16N, UK35, UK3-TWIN, UK5-TWIN	0.23
TS-RTK-BEN	0308210	URTK/S-BEN	0.84
TS-URTK/SS	0321213	URTK/SS	0.44

Mounting Rails

The design of these mounting rails complies with European standard EN 50045 (NS 15) and EN 50022 (NS 35), and feature outstanding accuracy and surface tempering. The steel rails are galvanized and yellow chromated. A line of dots is marked along the center of the rail to simplify drilling of mounting holes.

Length: 2m (6'6").



NS 35/7.5

Mfr.'s Type	Order No.	Dimensions (mm)			Each
		W	H	T	
NS 15 UNPERFORATED	1401695	15	5.5	1	9.00
NS 15 PERFORATED	1401682	15	5.5	1	10.00
NS 35/7.5 UNPERFORATED	0801681	35	7.5	1	11.00
NS 35/7.5 PERFORATED	0801733	35	7.5	1	12.00
NS 35/15 UNPERFORATED	1201714	35	15	1.5	22.00
NS 35/15 PERFORATED	1201730	35	15	1.5	23.00

End Brackets for Mounting Rails



Mounts to end of terminal block assembly to prevent blocks from being pushed along mounting rail. **Flammability Rating:** UL94V0. Color: gray

Mfr.'s Type	Order No.	Description	Each
E/MK 1	1421659	Snaps on NS 15 mounting rail, 6 mm wide.	.59
E/UK	1201442	For NS 32 or NS 35 rail, 9.5 mm wide.	.83
E/UK 1	1201413	As above, except for 2 and 3-level blocks.*	.88
Clipfix 35	3022218	Toolless for NS 35 rail, 9.5 mm wide	.69
E/NS 35N	0800886	One screw for NS 32 or NS 35 rail, 9.5mm wide.	.86

*10 mm wide

Reducing plug



Reducing plug for connecting a 4 mm test plug to a 2.3 mm test plug socket. Gray.

Mfr.'s Type RPS (Order No. 0201647)... 5.45 Each

Test Plug Sockets

4 mm test plug sockets for UK-terminal blocks.
Material: Silver-plated brass



Mfr.'s Type	Order No.	Fits Block	Each
PSB 3/10/4	0601292	UK2.5N, UK3N, UK5N	.32
PSB 4/7/6	0303299	UK6N, UK10N, UK16N	.49
PSB 6/5/6	0205290	UK35	.85

Stripping Tools



QUICK-WIREFOX 6



QUICK-WIREFOX 16

These stripping tools "automatically" adjust to the proper AWG depth. QUICK-WIREFOX 6 has an AWG range of 30-10 and QUICK-WIREFOX 16 has a range of AWG 10-6.

Mfr.'s Type	Order No.	Description	Each
QUICK-WIREFOX 6	1204384	Stripping Tool, AWG 30-10	50.00
QUICK-WIREFOX 16	1205105	Stripping Tool, AWG 10-6	93.00
QUICK-WIREFOX 6 EM	1204371	Repl. Blade for WIREFOX 6	22.00
QUICK-WIREFOX 16 EM	1204944	Repl. Blade for WIREFOX 16	32.00

Cable Cutter

Tempered steel to ensure high cutting efficiency over a long period of time. Conductors can be cut easily and cleanly due to the specific design of the blades. For copper and aluminum conductors and fixed bridges FBI10-6, FBI10-8, FBI10-10, FBI10-12. **Cutting capacity** (solid strand/multi-strand/fine strand): 10/8/4 AWG.



Mfr.'s Type	Order No.	Length	Each
Cutoff FB	1205985	175mm (6.9")	41.00

Screwdrivers for Spring Cage Terminal Blocks



Ideal for ZFK and ST Series spring cage terminal blocks.

- I Ergonomically designed
- I Fully insulated blade shaft
- I Flat tips

Mfr.'s Type	Order No.	Blade Size (mm)	Length (mm)	Each
SZF0-0.4X2.5	1204504	0.4T x 2.5W x 75	160	6.00
SZF1-0.6X3.5	1204517	0.6T x 3.5W x 100	180	7.00
SZF2-0.8X4.0	1204520	0.8T x 4.0W x 100	230	8.00

1907

The word TELEVISION first appeared in print in SCIENTIFIC AMERICAN Magazine.

Multi-Position PCB Terminal Blocks

These terminal blocks are fully enclosed and feature screw connections and nickel-plated copper alloy clamping parts. Both mini and standard versions are available, with straight or angled connections. The four standard versions also feature interlocking design for perfect alignment and pitch retention. Model **SMKDSP1.5** incorporates test connections for 2.3mm test plugs. **Color:** green (black or gray available). **Approvals:** ULRecognized, CSACertified.

	Mfr.'s Type	Order No.	No. of Pos.	Description	Dimensions (mm)			Each				
					W	H	L					
	MKDS1/2-3.81	1727010	2	Mini PC terminal block W/straight connections Pitch: 3.81 mm Specifications: UL: 300 V @ 10 A, 30-16 AWG IEC: 100 V @ 12 A, 26-16 AWG	7.3	8.5	7.61	.64				
	MKDS1/3-3.81	1727023	3				11.42	.96				
	MKDS1/4-3.81	1727036	4				15.23	1.28				
	MKDS1/5-3.81	1727049	5				19.04	1.59				
	MKDS1/6-3.81	1727052	6				22.85	1.92				
	MKDS1/7-3.81	1727065	7				26.66	2.23				
	MKDS1/8-3.81	1727078	8				30.47	2.55				
	MKDS1/9-3.81	1727081	9				34.28	2.88				
	MKDS1/10-3.81	1727094	10				38.09	3.19				
	MKDS1/11-3.81	1727104	11				41.89	3.15				
	MKDS1/12-3.81	1727117	12				45.69	3.84				
		SMKDS1/2-3.81	1728284				2	Above, except with 55° angled connections	10	9.5	7.61	.71
SMKDS1/3-3.81		1728297	3	11.42	1.06							
SMKDS1/4-3.81		1728307	4	15.23	1.40							
SMKDS1/5-3.81		1728310	5	19.04	1.76							
SMKDS1/6-3.81		1728323	6	22.85	2.11							
SMKDS1/7-3.81		1728336	7	26.66	2.82							
SMKDS1/8-3.81		1728349	8	30.47	2.46							
SMKDS1/9-3.81		1728352	9	34.28	3.17							
SMKDS1/10-3.81		1728365	10	38.09	3.51							
SMKDS1/11-3.81		1728378	11	41.89	3.87							
SMKDS1/12-3.81		1728381	12	45.69	4.22							
		MKDSN1.5/2-5.08	1729128	2	Standard PC terminal block W/straight connections Pitch: 5.08 mm Specifications: UL: 300 V @ 10 A, 30-14 AWG IEC: 250 V @ 13.5 A, 26-16 AWG	8.1	10				10.16	.54
	MKDSN1.5/3-5.08	1729131	3	15.24				.82				
	MKDSN1.5/4-5.08	1729144	4	20.32				1.09				
	MKDSN1.5/5-5.08	1729157	5	25.40				1.36				
	MKDSN1.5/6-5.08	1729160	6	30.48				1.63				
	MKDSN1.5/7-5.08	1729173	7	35.56				1.91				
	MKDSN1.5/8-5.08	1729186	8	40.64				2.17				
	MKDSN1.5/9-5.08	1729199	9	45.72				2.45				
	MKDSN1.5/10-5.08	1729209	10	50.80				2.72				
	MKDSN1.5/11-5.08	1729212	11	55.88				2.99				
	MKDSN1.5/12-5.08	1729225	12	60.96				3.26				
		SMKDSN1.5/2-5.08	1869211	2				As above, except with 55° angled connections	12	11	11.16	.63
SMKDSN1.5/3-5.08		1869224	3	16.24	.95							
SMKDSN1.5/4-5.08		1869237	4	21.33	1.26							
SMKDSN1.5/5-5.08		1869240	5	26.40	1.57							
SMKDSN1.5/6-5.08		1869253	6	31.48	1.89							
SMKDSN1.5/7-5.08		1869266	7	36.56	2.21							
SMKDSN1.5/8-5.08		1869279	8	41.64	2.52							
SMKDSN1.5/9-5.08		1869282	9	46.72	2.84							
SMKDSN1.5/10-5.08		1869295	10	51.80	3.16							
SMKDSN1.5/11-5.08		1869305	11	56.88	3.47							
SMKDSN1.5/12-5.08		1869318	12	61.96	3.78							
		MKDS1.5/2-5.08	1715721	2	Standard PC terminal block W/straight connections Pitch: 5.08 mm Specifications: UL: 300 V @ 10 A, 30-14 AWG IEC: 250 V @ 22 A, 26-14 AWG	9.8	13.8				10.16	.64
	MKDS1.5/3-5.08	1715734	3	15.24				.97				
	MKDS1.5/4-5.08	1715747	4	20.32				1.30				
	MKDS1.5/8-5.08	1715789	8	40.64				2.58				
	MKDS1.5/10-5.08	1715802	10	50.80				3.23				
	MKDS1.5/12-5.08	1715828	12	60.96				3.88				
		SMKDSP1.5/2-5.08	1733570	2				As above, except with 35° angled connections and test connections	13.4	15.3	10.16	.67
		SMKDSP1.5/3-5.08	1733583	3							15.24	1.01
		SMKDSP1.5/4-5.08	1733596	4							20.32	1.35
		SMKDSP1.5/5-5.08	1733606	5							25.40	1.68
		SMKDSP1.5/6-5.08	1733619	6							30.48	2.02
		SMKDSP1.5/7-5.08	1733622	7							35.56	2.36
SMKDSP1.5/8-5.08		1733635	8	40.64	2.69							
SMKDSP1.5/9-5.08		1733648	9	45.72	3.03							
SMKDSP1.5/10-5.08		1733651	10	50.80	3.36							
SMKDSP1.5/11-5.08		1733664	11	55.88	3.69							
SMKDSP1.5/12-5.08		1733677	12	60.96	4.03							
		MKDS3/2-5.08	1711725	2	Standard PC terminal block W/straight connections Pitch: 5.08 mm Specifications: UL: 300 V @ 15 A, 30-12 AWG IEC: 250 V @ 28 A, 24-12 AWG	11.2	18				10.16	1.02
	MKDS3/3-5.08	1711738	3	15.24				1.53				
	MKDS3/4-5.08	1712805	4	20.32				2.04				
	MKDS3/8-5.08	1712708	8	40.64				4.55				
	MKDS3/12-5.08	1714308	12	60.96				6.24				

Note

To label, optional self-adhesive marker cards are available: **SK3.81/2.8..** for blocks with 3.81 mm pitch or **SK5.08/3.8...** for blocks with 5.08 mm pitch. To order, see "Accessories".

MINI-COMBICON Plugs and Headers

The **Mini-Combicon** Series is a low profile connector with a generous wire range and is available from 2 to 20 positions. It features a unique design where each plug can be keyed specifically to a corresponding header to prevent mismatched connections in close proximity. The keying is accomplished by the combination of cutting away molded elements on the plugs, and inserting optional key tabs in the corresponding grooves of the header. **Color:** green (black or gray available). **Approvals:** ULRecognized, CSA Certified. Optional self-adhesive marker cards **SK3.81/2.8...** are used for labeling. To order, see "Accessories".

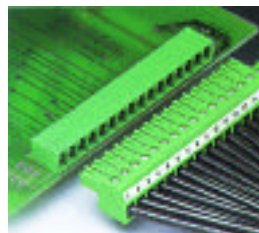

MC1.5/...-ST-...

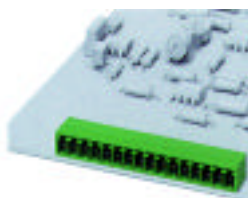

MC1.5/...-G-...

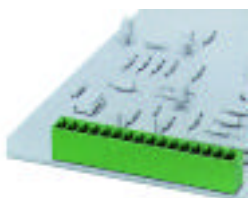

MCV1.5...-G-...

Mfr.'s Type	Order No.	No. of Pos.	Description	Dimensions (mm)			Each
				W	H	L	
MC1.5/2-ST-3.81	1803578	2	MINI-COMBICON plug w/straight plug-in Pitch: 3.81 mm Specifications: UL: 300 V @ 8 A, 30-14 AWG IEC: 160 V @ 8 A, 28-16 AWG	15.5	11.1	8.41	1.21
MC1.5/3-ST-3.81	1803581	3				12.22	1.81
MC1.5/4-ST-3.81	1803594	4				16.03	2.41
MC1.5/5-ST-3.81	1803604	5				19.30	3.04
MC1.5/6-ST-3.81	1803617	6				23.65	3.62
MC1.5/7-ST-3.81	1803620	7				27.46	4.22
MC1.5/8-ST-3.81	1803633	8				31.27	4.82
MC1.5/9-ST-3.81	1803646	9				35.08	5.43
MC1.5/10-ST-3.81	1803659	10				38.89	6.03
MC1.5/11-ST-3.81	1803662	11				42.70	6.63
MC1.5/12-ST-3.81	1803675	12				46.51	7.23
MC1.5/13-ST-3.81	1803688	13				50.32	7.84
MC1.5/14-ST-3.81	1803691	14				54.13	8.44
MC1.5/15-ST-3.81	1803701	15				57.94	9.04
MC1.5/16-ST-3.81	1803714	16				61.75	9.64
MC1.5/2-G-3.81	1803277	2				MINI-COMBICON header w/straight plug-in Pitch: 3.81mm Specifications: UL: 300 V @ 8 A IEC: 160 V @ 8 A	9.2
MC1.5/3-G-3.81	1803280	3	12.82	.63			
MC1.5/4-G-3.81	1803293	4	16.63	.84			
MC1.5/5-G-3.81	1803303	5	20.44	1.05			
MC1.5/6-G-3.81	1803316	6	24.25	1.26			
MC1.5/7-G-3.81	1803329	7	28.06	1.47			
MC1.5/8-G-3.81	1803332	8	31.87	1.67			
MC1.5/9-G-3.81	1803345	9	35.68	1.89			
MC1.5/10-G-3.81	1803358	10	39.49	2.10			
MC1.5/11-G-3.81	1803361	11	43.30	2.30			
MC1.5/12-G-3.81	1803374	12	47.11	2.52			
MC1.5/13-G-3.81	1803387	13	50.92	2.73			
MC1.5/14-G-3.81	1803390	14	54.73	2.93			
MC1.5/15-G-3.81	1803400	15	58.54	3.14			
MC1.5/16-G-3.81	1803413	16	62.35	3.36			
MCV1.5/2-G-3.81	1803426	2	MINI-COMBICON header w/vertical plug-in Pitch: 3.81 mm Specifications: UL: 300 V @ 8 A IEC: 160 V @ 8 A	7.25	9.2		
MCV1.5/3-G-3.81	1803439	3				12.82	.63
MCV1.5/4-G-3.81	1803442	4				16.63	.84
MCV1.5/5-G-3.81	1803455	5				20.44	1.05
MCV1.5/6-G-3.81	1803468	6				24.25	1.26
MCV1.5/7-G-3.81	1803471	7				28.06	1.47
MCV1.5/8-G-3.81	1803484	8				31.87	1.67
MCV1.5/9-G-3.81	1803497	9				35.68	1.89
MCV1.5/10-G-3.81	1803507	10				39.49	2.10
MCV1.5/11-G-3.81	1803510	11				43.30	2.30
MCV1.5/12-G-3.81	1803523	12				47.11	2.52
MCV1.5/13-G-3.81	1803536	13				50.92	2.73
MCV1.5/14-G-3.81	1803549	14				54.73	2.89
MCV1.5/15-G-3.81	1803552	15				58.54	3.14
MCV1.5/16-G-3.81	1803565	16				62.35	3.36
CP-MSTB	1734634					Insertable key tabs, red (100 piece package). Inserts into the slots on Mini-Combicon headers.	

COMBICON Plugs and Headers





Standard **COMBICON** plugs and headers are available in 2 to 24 positions with and without screw flanges and in 5.08 mm pitch (5.0 mm pitch also available). They feature generous connection space and higher voltage and current ratings than the MINI-COMBICON series. Plugs with 2.3 mm test connections are also available (call for details). **Color:** Green (black or gray available on request). **Approvals:** UL recognized, CSA Certified. Optional self-adhesive marker cards **SK5.08/3.8...** are used for labeling. To order, see "Accessories".

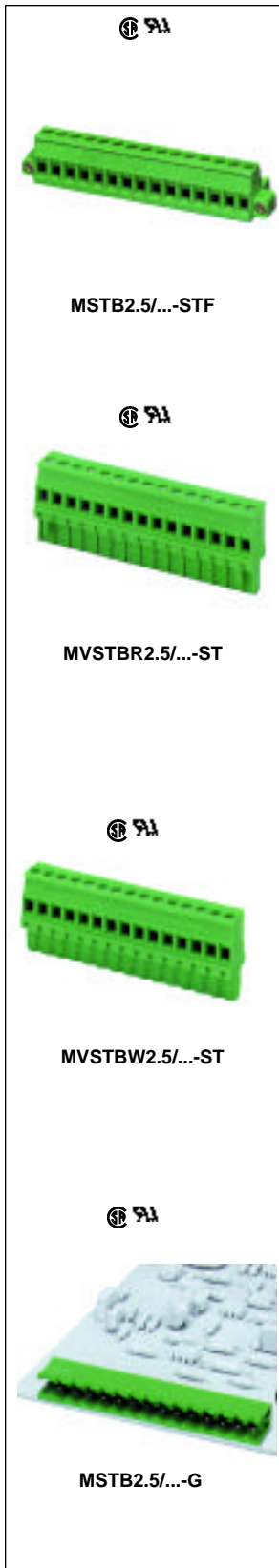

Mfr.'s Type	Order No.	No. of Pos.	Description	Dimensions (mm)			Each
				W	H	L	
MSTB2.5/2-ST-5.08	1757019	2	COMBICON plug w/straight plug-in Pitch: 5.08 mm Specifications: UL: 300 V @ 10 A, 30-12 AWG IEC: 250 V @ 12 A, 24-12 AWG	18.2	15	10.16	1.04
MSTB2.5/3-ST-5.08	1757022	3				15.24	1.55
MSTB2.5/4-ST-5.08	1757035	4				20.36	2.06
MSTB2.5/5-ST-5.08	1757048	5				25.40	2.57
MSTB2.5/6-ST-5.08	1757051	6				30.48	3.09
MSTB2.5/7-ST-5.08	1757064	7				35.56	3.60
MSTB2.5/8-ST-5.08	1757077	8				40.14	4.11
MSTB2.5/9-ST-5.08	1757080	9				45.72	4.64
MSTB2.5/10-ST-5.08	1757093	10				50.80	5.15
MSTB2.5/11-ST-5.08	1757103	11				55.88	5.66
MSTB2.5/12-ST-5.08	1757116	12				60.96	6.17
MSTB2.5/13-ST-5.08	1757129	13				66.04	7.58
MSTB2.5/14-ST-5.08	1757132	14				71.12	8.17
MSTB2.5/15-ST-5.08	1757145	15				76.20	8.75
MSTB2.5/16-ST-5.08	1757158	16				81.28	9.33
MSTB2.5/17-ST-5.08	1757161	17				86.36	9.91
MSTB2.5/18-ST-5.08	1757174	18				91.44	10.50
MSTB2.5/19-ST-5.08	1757187	19				96.52	11.09
MSTB2.5/20-ST-5.08	1757190	20				101.60	11.67
MSTB2.5/21-ST-5.08	1757200	21				106.68	12.25
MSTB2.5/22-ST-5.08	1757213	22				111.76	12.83
MSTB2.5/23-ST-5.08	1757226	23				116.84	13.41
MSTB2.5/24-ST-5.08	1757239	24				121.92	13.99

COMBICON Plugs and Headers (Continued on next page)



Mfr.'s Type	Order No.	No. of Pos.	Description	Dimensions (mm)			Each	
				W	H	L		
 MSTB2.5/...-STF	MSTB2.5/2-STF-5.08	1777989	2	COMBICON plug w/straight plug-in and screw flanges Pitch: 5.08 mm Specifications: UL: 300 V @ 10 A, 30-12 AWG IEC: 250 V @ 12 A, 24-12 AWG Note: Length includes screw flanges	18.2	15	19.96	1.32
	MSTB2.5/3-STF-5.08	1777992	3				25.04	1.96
	MSTB2.5/4-STF-5.08	1778001	4				30.12	2.60
	MSTB2.5/5-STF-5.08	1778014	5				35.30	3.23
	MSTB2.5/6-STF-5.08	1778027	6				40.28	3.88
	MSTB2.5/7-STF-5.08	1778030	7				45.36	4.52
	MSTB2.5/8-STF-5.08	1778043	8				50.44	5.16
	MSTB2.5/9-STF-5.08	1778056	9				55.52	5.79
	MSTB2.5/10-STF-5.08	1778069	10				60.60	6.44
	MSTB2.5/11-STF-5.08	1778072	11				65.68	7.08
	MSTB2.5/12-STF-5.08	1778085	12				70.76	7.72
	MSTB2.5/13-STF-5.08	1778098	13				75.84	8.35
	MSTB2.5/14-STF-5.08	1778108	14				80.92	9.00
	MSTB2.5/15-STF-5.08	1778111	15				86.00	9.64
	MSTB2.5/16-STF-5.08	1778124	16				91.08	10.26
	MSTB2.5/17-STF-5.08	1778137	17				96.16	10.91
	MSTB2.5/18-STF-5.08	1778140	18				101.24	11.56
	MSTB2.5/19-STF-5.08	1778153	19				106.32	12.20
	MSTB2.5/20-STF-5.08	1778166	20				111.40	12.84
	 MVSTBR2.5/...-ST	MVSTBR2.5/2-ST-5.08	1792249				2	COMBICON plug w/plug-in direction vertical to the conductor axis and connection point facing the smooth wall of the header. Pitch: 5.08 mm Specifications: UL: 300 V @ 10 A, 30-12 AWG IEC: 250 V @ 12 A, 24-12 AWG Note: Can be key-coded using optional coding tabs CP-MSTB (for the plug) and CR-MSTB (for the corresponding header). To order, see "Accessories".
MVSTBR2.5/3-ST-5.08		1792252	3	15.24	1.77			
MVSTBR2.5/4-ST-5.08		1792265	4	20.32	2.37			
MVSTBE2.5/5-ST-5.08		1792278	5	25.40	2.96			
MVSTBR2.5/6-ST-5.08		1792281	6	30.48	3.56			
MVSTBR2.5/7-ST-5.08		1792294	7	35.56	4.15			
MVSTBE2.5/8-ST-5.08		1792304	8	40.64	4.74			
MVSTBR2.5/9-ST-5.08		1792317	9	45.72	5.34			
MVSTBR2.5/10-ST-5.08		1792320	10	50.80	5.92			
MVSTBR2.5/11-ST-5.08		1792333	11	55.88	6.52			
MVSTBR2.5/12-ST-5.08		1492346	12	60.96	7.11			
MVSTBR2.5/13-ST-5.08		1792359	13	66.04	7.73			
MVSTBR2.5/14-ST-5.08		1792362	14	71.12	8.35			
MVSTBR2.5/15-ST-5.08		1792375	15	76.20	8.97			
MVSTBR2.5/16-ST-5.08		1792388	16	81.28	9.59			
MVSTBR2.5/17-ST-5.08		1792391	17	86.36	10.21			
MVSTBR2.5/18-ST-5.08		1792401	18	91.44	10.83			
MVSTBR2.5/19-ST-5.08		1792414	19	96.52	11.45			
MVSTBR2.5/20-ST-5.08		1792427	20	101.60	12.07			
MVSTBR2.5/21-ST-5.08		1792430	21	106.68	12.69			
MVSTBR2.5/22-ST-5.08		1792443	22	111.76	13.31			
MVSTBR2.5/23-ST-5.08		1792456	23	116.84	13.93			
MVSTBR2.5/24-ST-5.08		1792469	24	121.92	14.55			
 MVSTBW2.5/...-ST		MVSTBW2.5/2-ST-5.08	1792757	2	As above, except connection point faces the rippled wall of the header. Pitch: 5.08 mm Specifications: UL: 300 V @ 10 A, 30-12 AWG IEC: 250 V @ 12 A, 24-12 AWG Note: Can be key-coded using optional coding tabs CP-MSTB (for the plug) and CR-MSTB (for the corresponding header). To order, see "Accessories".	12.6	26	
	MVSTBW2.5/3-ST-5.08	1792760	3	15.24				1.77
	MVSTBW2.5/4-ST-5.08	1792773	4	20.32				2.37
	MVSTBW2.5/5-ST-5.08	1792786	5	25.40				2.96
	MVSTBW2.5/6-ST-5.08	1792799	6	30.48				3.56
	MVSTBW2.5/7-ST-5.08	1792809	7	35.56				4.15
	MVSTBW2.5/8-ST-5.08	1792812	8	40.64				4.74
	MVSTBW2.5/9-ST-5.08	1792825	9	45.72				5.34
	MVSTBW2.5/10-ST-5.08	1792838	10	50.80				5.92
	MVSTBW2.5/11-ST-5.08	1792841	11	55.88				6.52
	MVSTBW2.5/12-ST-5.08	1792854	12	60.96				7.11
	MVSTBW2.5/13-ST-5.08	1792867	13	66.04				7.73
	MVSTBW2.5/14-ST-5.08	1792870	14	71.12				8.35
	MVSTBW2.5/15-ST-5.08	1792883	15	76.20				8.97
	MVSTBW2.5/16-ST-5.08	1792896	16	81.28				9.59
	MVSTBW2.5/17-ST-5.08	1792906	17	86.36				10.21
	MVSTBW2.5/18-ST-5.08	1792919	18	91.44				10.83
	MVSTBW2.5/19-ST-5.08	1792922	19	96.52				11.45
	MVSTBW2.5/20-ST-5.08	1792935	20	101.60				12.07
	MVSTBW2.5/21-ST-5.08	1792948	21	106.68				12.69
	MVSTBW2.5/22-ST-5.08	1792951	22	111.76				13.31
	MVSTBW2.5/23-ST-5.08	1792964	23	116.84				13.93
	MVSTBW2.5/24-ST-5.08	1792977	24	121.92				14.55
	 MSTB2.5/...-G	MSTB2.5/2-G-5.08	1759017	2				COMBICON header, open end w/right angled contact/solder pins. Pitch: 5.08 mm Specifications: UL: 300 V @ 10 A IEC: 250 V @ 12 A
MSTB2.5/3-G-5.08		1759020	3	15.24	.54			
MSTB2.5/4-G-5.08		1759033	4	20.32	.72			
MSTB2.5/5-G-5.08		1759046	5	25.40	.90			
MSTB2.5/6-G-5.08		1759059	6	30.48	1.07			
MSTB2.5/7-G-5.08		1759062	7	35.56	1.25			
MSTB2.5/8-G-5.08		1759075	8	40.64	1.43			
MSTB2.5/9-G-5.08		1759088	9	45.72	1.61			
MSTB2.5/10-G-5.08		1759091	10	50.80	1.79			
MSTB2.5/11-G-5.08		1759101	11	55.88	1.97			
MSTB2.5/12-G-5.08		1759114	12	60.96	2.15			
MSTB2.5/13-G-5.08		1759127	13	66.04	2.34			
MSTB2.5/14-G-5.08		1759130	14	71.12	2.52			
MSTB2.5/15-G-5.08		1759143	15	76.20	2.70			
MSTB2.5/16-G-5.08		1759156	16	81.28	2.88			
MSTB2.5/17-G-5.08		1759169	17	86.36	3.06			
MSTB2.5/18-G-5.08		1759172	18	91.44	3.24			
MSTB2.5/19-G-5.08		1759185	19	96.52	3.42			
MSTB2.5/20-G-5.08		1759198	20	101.60	3.60			
MSTB2.5/21-G-5.08		1759208	21	106.68	3.78			
MSTB2.5/22-G-5.08		1759211	22	111.76	3.96			
MSTB2.5/23-G-5.08		1759224	23	116.84	4.14			
MSTB2.5/24-G-5.08		1759237	24	121.92	4.32			

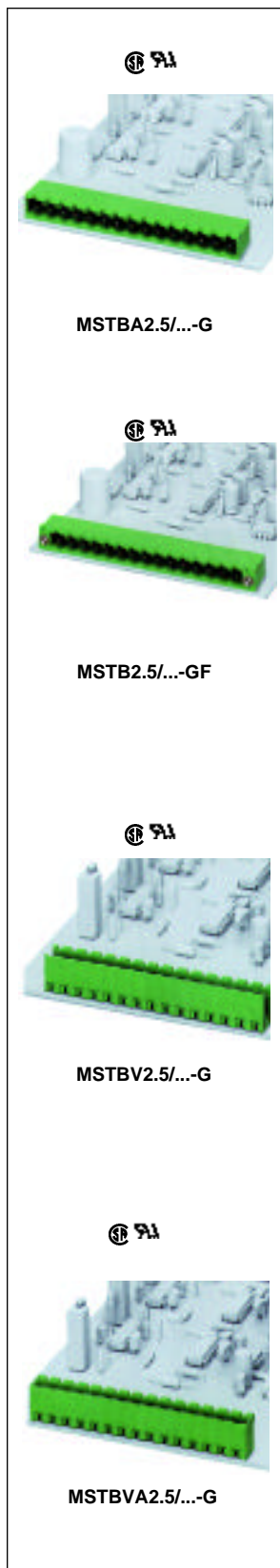

Mfr.'s Type	Order No.	No. of Pos.	Description	Dimensions (mm)			Each
				W	H	L	
MSTBA2.5/2-G-5.08	1757242	2	COMBICON headers with side panels with right angled contact/solder pins Pitch: 5.08 mm Specifications: UL: 150 V @ 15 A & 300 V @ 10 A IEC: 250 V @ 12A	12	8.6	12.16	.36
MSTBA2.5/3-G-5.08	1757255	3				17.24	.54
MSTBA2.5/4-G-5.08	1757268	4				22.32	.72
MSTBA2.5/5-G-5.08	1757271	5				27.40	.90
MSTBA2.5/6-G-5.08	1757284	6				32.48	1.07
MSTBA2.5/7-G-5.08	1757297	7				37.56	1.25
MSTBA2.5/8-G-5.08	1757307	8				42.64	1.43
MSTBA2.5/9-G-5.08	1757310	9				47.72	1.61
MSTBA2.5/10-G-5.08	1757323	10				52.80	1.71
MSTBA2.5/11-G-5.08	1757336	11				57.88	1.97
MSTBA2.5/12-G-5.08	1757349	12				62.96	2.15
MSTBA2.5/13-G-5.08	1757352	13				68.04	2.64
MSTBA2.5/14-G-5.08	1757365	14				73.12	2.85
MSTBA2.5/15-G-5.08	1757378	15				78.20	3.04
MSTBA2.5/16-G-5.08	1757381	16				83.28	3.24
MSTBA2.5/17-G-5.08	1757394	17				88.36	3.45
MSTBA2.5/18-G-5.08	1757404	18				93.44	3.65
MSTBA2.5/19-G-5.08	1757417	19				98.52	3.86
MSTBA2.5/20-G-5.08	1757420	20				103.60	4.06
MSTBA2.5/21-G-5.08	1757433	21				108.68	4.26
MSTBA2.5/22-G-5.08	1757446	22				113.76	4.47
MSTBA2.5/23-G-5.08	1757459	23				118.84	4.66
MSTBA2.5/24-G-5.08	1757462	24				123.92	4.88
MSTB2.5/2-GF-5.08	1776508	2				COMBICON header w/screw flanges,with right angled contact/solder pins Pitch: 5.08 mm Specifications: UL: 150 V @ 15 A & 300 V @ 10 A IEC: 250 V @ 12 A	12
MSTB2.5/3-GF-5.08	1776511	3	25.40	1.63			
MSTB2.5/4-GF-5.08	1776524	4	30.48	1.85			
MSTB2.5/5-GF-5.08	1776537	5	35.56	2.06			
MSTB2.5/6-GF-5.08	1776540	6	40.64	2.28			
MSTB2.5/7-GF-5.08	1776553	7	45.72	2.50			
MSTB2.5/8-GF-5.08	1776566	8	50.80	2.71			
MSTB2.5/9-GF-5.08	1776579	9	55.88	2.94			
MSTB2.5/10-GF-5.08	1776582	10	60.96	3.15			
MSTB2.5/11-GF-5.08	1776595	11	66.04	3.37			
MSTB2.5/12-GF-5.08	1776605	12	71.12	3.59			
MSTB2.5/13-GF-5.08	1776618	13	76.20	3.80			
MSTB2.5/14-GF-5.08	1776621	14	81.28	4.02			
MSTB2.5/15-GF-5.08	1776634	15	86.36	4.23			
MSTB2.5/16-GF-5.08	1776647	16	91.44	4.46			
MSTB2.5/18-GF-5.08	1776663	18	101.60	4.90			
MSTB2.5/19-GF-5.08	1776676	19	106.68	5.11			
MSTB2.5/20-GF-5.08	1776689	20	111.76	5.32			
MSTBV2.5/2-G-5.08	1758018	2	COMBICON header, open-end, with vertical plug-in Pitch: 5.08 mm Specifications: UL: 150 V @ 15 A & 300 V @ 10 A IEC: 250 V @ 12 A	8.6	12		
MSTBV2.5/3-G-5.08	1758021	3				15.24	.54
MSTBV2.5/4-G-5.08	1758034	4				20.32	.72
MSTBV2.5/5-G-5.08	1758047	5				25.40	.90
MSTBV2.5/6-G-5.08	1758050	6				30.48	1.07
MSTBV2.5/7-G-5.08	1758063	7				35.56	1.23
MSTBV2.5/8-G-5.08	1758076	8				40.64	1.43
MSTBV2.5/9-G-5.08	1758089	9				45.72	1.61
MSTBV2.5/10-G-5.08	1758092	10				50.80	1.79
MSTBV2.5/11-G-5.08	1758102	11				55.88	1.97
MSTBV2.5/12-G-5.08	1758115	12				60.96	2.15
MSTBV2.5/13-G-5.08	1758128	13				66.04	2.64
MSTBV2.5/14-G-5.08	1758131	14				71.12	2.85
MSTBV2.5/15-G-5.08	1758144	15				76.20	3.04
MSTBV2.5/16-G-5.08	1758157	16				81.28	3.24
MSTBV2.5/17-G-5.08	1758160	17				86.36	3.45
MSTBV2.5/18-G-5.08	1758173	18				91.44	3.65
MSTBV2.5/19-G-5.08	1758186	19				96.52	3.86
MSTBV2.5/20-G-5.08	1758199	20				101.60	4.06
MSTBV2.5/21-G-5.08	1758209	21				106.68	4.26
MSTBV2.5/22-G-5.08	1758212	22				111.76	4.47
MSTBV2.5/23-G-5.08	1758225	23				116.84	4.66
MSTBV2.5/24-G-5.08	1758238	24				121.92	4.88
MSTBVA2.5/2-G-5.08	1755736	2				COMBICON header with side panels, with vertical plug-in Pitch: 5.08 mm Specifications: UL: 150 V @ 15 A & 300 V @ 10 A IEC: 250 V @ 12 A	8.6
MSTBVA2.5/3-G-5.08	1755749	3	17.24	.54			
MSTBVA2.5/4-G-5.08	1755752	4	22.32	.72			
MSTBVA2.5/5-G-5.08	1755765	5	27.40	.90			
MSTBVA2.5/6-G-5.08	1755778	6	32.48	1.07			
MSTBVA2.5/7-G-5.08	1755781	7	37.56	1.23			
MSTBVA2.5/8-G-5.08	1755794	8	42.64	1.43			
MSTBVA2.5/9-G-5.08	1755804	9	47.72	1.61			
MSTBVA2.5/10-G-5.08	1755817	10	52.80	1.79			
MSTBVA2.5/11-G-5.08	1755820	11	57.88	1.97			
MSTBVA2.5/12-G-5.08	1755833	12	62.96	2.15			
MSTBVA2.5/13-G-5.08	1755846	13	68.04	2.64			
MSTBVA2.5/14-G-5.08	1755859	14	73.12	2.85			
MSTBVA2.5/15-G-5.08	1755862	15	78.20	3.04			
MSTBVA2.5/16-G-5.08	1755875	16	83.28	3.24			
MSTBVA2.5/17-G-5.08	1755888	17	88.36	3.45			
MSTBVA2.5/18-G-5.08	1755891	18	93.44	3.65			
MSTBVA2.5/19-G-5.08	1755901	19	98.52	3.86			
MSTBVA2.5/20-G-5.08	1755914	20	103.60	4.06			
MSTBVA2.5/21-G-5.08	1755927	21	108.68	4.26			
MSTBVA2.5/22-G-5.08	1755930	22	113.76	4.47			
MSTBVA2.5/23-G-5.08	1755943	23	118.84	4.66			
MSTBVA2.5/24-G-5.08	1755956	24	123.92	4.88			

The MDSTB2.5/...-G-double-level headers are offset by 10 mm in the plug-in direction and by half a pitch (2.54 mm) to improve visibility of and accessibility to the bottom level. By fitting the 2-and 3-position double-level blocks in rows so that they interlock, any number of straight plug-in positions can be created. The levels of MDSTB2.5/...-G1 are not offset. They are supplied in blocks with 3, 4, 6, or up to 20 fixed positions per level and always have side panels to prevent incorrect plug insertion. **Color:** green (black or gray available on request). **Approvals:** ULRecognized, CSACertified. Optional self-adhesive marker cards SK5.08/3.08 mm are used for labeling. To order, see "accessories" below.

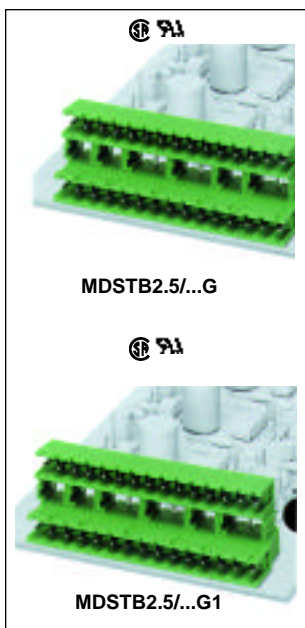

Mfr.'s Type	Order No.	No. of Pos.	Description	Dimensions (mm)			Each
				W	H	L	
MDSTB2.5/2-G-5.08	1762062	2	Double-level COMBICON header, open-end , with offset levels and right angled contact/solder pins. Pitch: 5.08 mm Specifications: UL: 150 V @ 15 A & 300 V @ 10 A IEC: 250 V @ 10 A	22.32*	23.5	12.70	1.31
MDSTB2.5/3-G-5.08	1762075	3		22.32*	23.5	17.79	1.96
MDSTB-SE	1786679		Optional side element for lateral sealing of MDSTB2.5/...-G Optional ejector, assembles on each side of MDSTB2.5/...-G				.25
MDSTB2.5-AS	1806588						2.10
MDSTB2.5/3-G1-5.08	1762376	3	Double-level COMBICON header with Side panels, without offset levels, W / right angled contact / solder pins Pitch: 5.08 mm Rating: 250 V, 10 A	22	28.5	17.24	2.22
MDSTB2.5/4-G1-5.08	1736713	4				22.32	2.79
MDSTB2.5/6-G1-5.08	1762415	6				32.48	4.46
MDSTB2.5/7-G1-5.08	1762428	7				37.56	5.20
MDSTB2.5/8-G1-5.08	1762431	8				42.64	5.94
MDSTB2.5/9-G1-5.08	1762444	9				47.72	6.68
MDSTB2.5/10-G1-5.08	1762457	10				52.80	7.43
MDSTB2.5/11-G1-5.08	1762460	11				57.88	8.17
MDSTB2.5/12-G1-5.08	1762703	12				62.96	8.91
MDSTB2.5/13-G1-5.08	1762473	13				68.04	9.65
MDSTB2.5/14-G1-5.08	1762486	14				73.12	10.39
MDSTB2.5/15-G1-5.08	1762499	15				78.20	11.14
MDSTB2.5/16-G1-5.08	1762509	16				83.28	11.88
MDSTB2.5/17-G1-5.08	1762512	17				88.36	12.63
MDSTB2.5/18-G1-5.08	1762525	18				93.44	13.36
MDSTB2.5/19-G1-5.08	1762538	19				98.52	14.11
MDSTB2.5/20-G1-5.08	1762680	20				103.60	14.85

*lower level width

Power-COMBICON Plugs and Headers

POWER-COMBICON is a new improved version of the "standard" COMBICON connectors. It features a higher current capacity, an extended wire range and a small pitch of 7.62 mm. Both the plugs and headers can be key coded using optional CP-HCC4 coding tabs. **Color:** green. **Approvals:** ULRecognized, CSA Certified. Optional self-adhesive marker cards SK 7.62/3.8 mm are used for labeling. To order, see "Accessories" below.

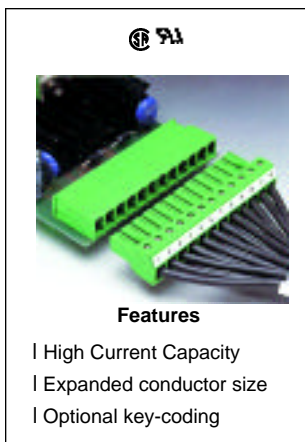

Mfr.'s Type	Order No.	No. of Pos.	Description	Dimensions (mm)			Each
				W	H	L	
PC4/2-ST-7.62	1804904	2	POWER-COMBICON plug with straight Plug-in Pitch: 7.62 mm AWG: 24-10 Rating: 400 V, 20 A	30.7	18	15.22	2.83
PC4/3-ST-7.62	1804917	3				22.84	4.23
PC4/4-ST-7.62	1804920	4				30.46	5.65
PC4/5-ST-7.62	1804933	5				38.08	7.06
PC4/6-ST-7.62	1804946	6				45.70	8.48
PC4/7-ST-7.62	1804959	7				53.32	9.88
PC4/8-ST-7.62	1804962	8				60.94	11.30
PC4/9-ST-7.62	1804975	9				68.57	12.71
PC4/10-ST-7.62	1804988	10				76.18	14.13
PC4/11-ST-7.62	1804991	11				83.80	15.53
PC4/12-ST-7.62	1805000	12				91.42	16.94
PC4/2-G-7.62	1804797	2				POWER-COMBICON header with Right angled contact/solder pins Pitch: 7.62 mm Rating: 400 V, 20 A	29
PC4/3-G-7.62	1804907	3	22.84	4.23			
PC4/4-G-7.62	1804810	4	30.46	5.65			
PC4/5-G-7.62	1804823	5	38.08	7.06			
PC4/6-G-7.62	1804836	6	45.70	8.48			
PC4/7-G-7.62	1804849	7	53.32	9.88			
PC4/8-G-7.62	1804852	8	60.94	11.30			
PC4/9-G-7.62	1804865	9	68.57	12.71			
PC4/10-G-7.62	1804878	10	76.18	14.13			
PC4/11-G-7.62	1804981	11	83.80	15.53			
PC4/12-G-7.62	1804894	12	91.42	16.74			
CP-HCC4	1600027		Insertable key tabs (100 piece package). Inserts into the slots On the POWER-COMBICON plugs and headers.				

Accessories for PCB Terminal Blocks and COMBICON Connectors

Mfr.'s Type	Order No.	Description	Each
SK3.81/2.8 :UNPRINTED	5527698	140 pc. Marker card, unprinted, 14 rows of 10 w/pitch division marks	3.73
SK3.81/2.8:1-10	5600009	140 pc. Marker card, 14 rows of 10 identical consec. nos. 1-10, 11-20, etc: up to 91-100 (specify)	3.73
SK5.08/3.8: UNPRINTED	5527740	120 pc. Marker card, unprinted, 12 rows of 10 w/pitch division marks	3.20
SH5.08/3.8:1-10	5600014	120 pc. Marker card, 12 rows of 10 identical consec. nos. 1-10, 11-20, etc: up to 91-100 (specify)	3.20
SK7.62/3.8:UNPRINTED	5527779	120 pc. Marker card, unprinted, 12 rows of 10 w/pitch division marks	3.20
SK7.62/3.8:1-10	5600017	120 pc. Marker card, 12 rows of 10 identical consec. nos. 1-10,11-20, etc: up to 91-100 (specify)	3.20
RPS	0201647	Test plug for SMKDSP1.5 for connecting a 4 mm test plug to a 2.3 mm test socket, gray	5.45
CP-MSTB	1734634	Insertable key tabs, red (100 pc. package)	0.05
CR-MSTB	1734401	Insertable key tabs, red (100 pc. package)	0.05

Approvals: CE, VDE, CSA(CE only for PLC-R.../21-21 and PLC-R.../1-1/ACT; VDE, UL, CSA Applied for)

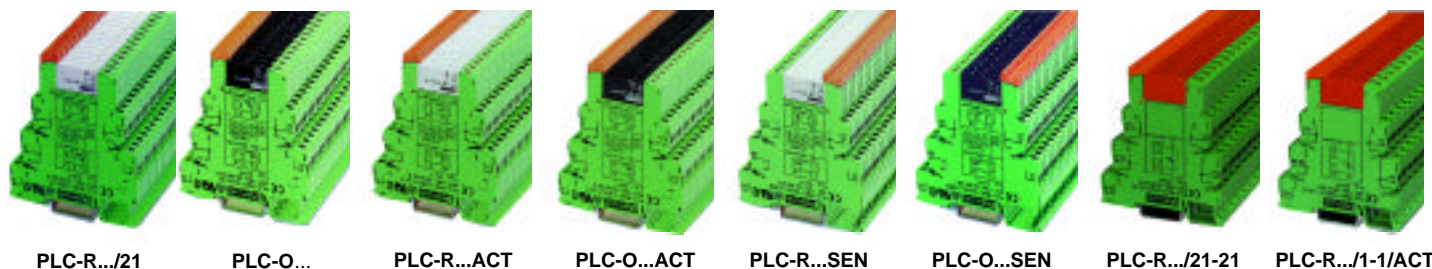

The **PLC** interface provides all the advantages of proven modular terminal block technology. As an interface between an automated device and the system peripherals, it is equipped with either a plug-in miniature relay (**PLC-R**) or optocoupler (**PLC-O**) which is easily removed with the built-in ejector latch. Additional options are provided by the actuators (...**ACT**) and sensor (...**SEN**) versions, which accept all connections directly at the interface without additional power distribution blocks. Insulated, color-coded plug-in jumpers (32A) permit bridging of modules. The jumper, which can be used on the input and output sides, is a continuous bridge which can be cut to length. Input terminal block (**PLC-ESK**) is the same shape as the PLC interface terminal blocks. It is used to feed bridging potentials and has a nominal current of 32 A. When total current is less than or equal to 6 A, the inputs can take place directly at the PLC interface terminal blocks. Separating plate **PLC-ATP**, is always required at the start and end of each terminal strip. It can be used for visual separation of groups, separation of neighboring bridges or separation of PLC interfaces with voltages greater than 250 V. PLC-ATP has pre-scored breakout points at the bridging positions so that individual bridges can pass through if needed. Relays and optocouplers are hermetically sealed (IP67). **Mounting:** NS35 rails. **Flammability Rating:** UL94V0. **AWG Range:** 26-14. **Connections:** screw. **Color:** green. **Dimensions:** (W x L x H): 6.2 x 80 x 94 mm (terminal width of PLC-R.../21-21 and PLC-R.../1-1/ACT is 14 mm). Marker strips for labeling are available.

Mfr.'s Type	Order No.	Description	Input Voltage	Each
PLC-RSC-24DC/21AU PLC-RSC-24UC/21AU PLC-RSC-120UC/21AU PLC-RSC-230UC/21AU	2966265 2966278 2966281 2966294	PLC standard series w/plugable relay (SPDT): AgSnO + gold plated contacts	24 VDC 24 VAC/DC 120 VAC/110VDC 230VAC/220VDC	19.00 22.00 24.00 28.00
PLC-RSC-24DC/21 PLC-RSC-24UC/21 PLC-RSC-120UC/21 PLC-RSC-230UC/21	2966171 2966184 2966197 2966207	As above, except w/ AgSnO contacts	24 VDC 24 VAC/DC 120 VAC/110 VDC 230 VAC/220 VDC	14.00 21.50 16.00 26.00
PLC-OSC-24DC/48DC/100 PLC-OSC-120UC/48DC/100 PLC-OSC-230UC/48DC/100	2966728 2966744 2966757	PLC standard series w/plugable input optical coupler	24 VDC 120 VAC/110 VDC 230 VAC/220 VDC	27.00 34.00 34.00
PLC-OSC-24DC/24DC/2 PLC-OSC-120UC/24DC/2 PLC-OSC-230UC/24DC/2	2966634 2966650 2966663	As above, except w/ power optical coupler	24 VDC 120 VAC/110 VDC 230 VAC/220 VDC	40.00 44.00 44.00
PLC-RSC-24DC/1/ACT	2966210	PLC actuator w/plugable relay (1 N/O): W/AgSnO Contacts	24 VDC	17.00
PLC-OSC-24DC/24DC/2/ACT	2966676	PLC actuator w/plugable power optical coupler	24 VDC	40.00
PLC-RSC-24DC/1AU/SEN PLC-RSC-120UC/1AU/SEN PLC-RSC-230UC/1AU/SEN	2966317 2966320 2966333	PLC sensor w/plugable relay (1 N/O), w/AgSnO contacts	24 VDC 120 VAC/110 VDC 230 VAC/220 VDC	18.00 24.00 27.00
PLC-OSC-24DC/48DC/100/SEN PLC-OSC-120UC/48DC/100/SEN PLC-OSC-230UC/48DC/100/SEN	2966773 2966799 2966809	PLC sensor w/plugable input optical coupler	24 VDC 120 VAC/110 VDC 230 VAC/220 VDC	26.00 33.00 34.00
PLC-RSC-24DC/21-21AU PLC-RSC-24UC/21-21AU PLC-RSC-120UC/21-21AU PLC-RSC-230UC/21-21AU	2967125 2967112 2967138 2967141	PLC standard series w/plugable relay (2PDT), w/AgNi + gold plated contacts	24 VDC 24 VAC/DC 120 VAC/110 VDC 230 VAC/220 VDC	27.00 28.00 36.00 36.00
PLC-RSC-24DC/21-21 PLC-RSC-24UC/21-21 PLC-RSC-120UC/21-21 PLC-RSC-230UC/21-21	2967060 2967073 2967086 2967099	As above, except AgNi contacts	24 VDC 24 VAC/DC 120 VAC/110 VDC 230 VAC/220 VDC	19.00 26.00 23.00 34.00
PLC-RSC-24DC/1-1/ACT	2967109	PLC actuator w/plugable relay (2 N/O), w/AgNi contacts	24 VDC	26.00

Accessories for PLC Series

Mfr.'s Type	Order No.	Description	For Terminal Blocks	Each
PLC-ESK GY	2966508	Input terminal block, 9 mm wide, AWG 24-10, 250 V, 32 A, gray	All PLC blocks	15.00
PLC-ATP BK	2966841	Separating plate, 2 mm thick, black	All PLC Blocks	1.49
FBST500-PLC RD FBST500-PLC BU FBST500-PLC GY	2966786 2966692 2966838	Plug-in jumper, 500 mm (19.7") long, 32 A max., cuttable, Red Blue Gray	All PLC Blocks	16.00 16.00 16.00
ZB 6 ZB 10	Marker strips (order data, see "Accessories for Terminal Blocks" in Modular Terminal Block section)	All PLC blocks, except PLC-R.../21-21, PLC-R.../1-1/ACT PLC-R.../21-21, PLC-R.../1-1/ACT	.91 .91

Varioface modules are universal interface elements that simplify system wiring between the peripherals and input-output levels of automation devices. They are electrically connected, position by position, on the input and output sides. These modules are available with either ribbon or D-Sub connectors, with or without a light indicator in each signal path. The ribbon connector modules offer a compact 2-level version with 2.3 mm test connections (**FLK**), a standard 2-level version (**FLKM**), and a 3-level version (**FLKMS**). The D-Sub connector modules offer a compact 3-level version with test connections (**FLK-D...SUB**), a standard 2-level version (**FLKM-D...SUB**) and a 2-level version with a light indicator for each connection point (**FLKM-D...SUB/LA**). Each module includes a **PMB** marker carrier for labeling the module. **Connections:** screw. **Color:** green. Mounting: universal.



FLK 10...26



FLKM 10...64



FLKMS 16...64



FLK-D...SUB



FLKM-D...SUB



FLKM-D...SUB/LA

Mfr.'s Type	Order No.	No. of pos.	Description	Dimensions (mm)			Each
				W	H	L	
FLK 10...26	FLK 10	2280077	Ribbon cable pin strip module, compact 2-level w/test connections AWG: 24-12 Rating: 60 VAC, 1A	50	56.6	60.0	32.00
	FLK 16	2280080				60.0	42.00
	FLK 20	2280019				60.0	41.00
	FLK 26	2280051				75.5	52.00
FLKM 10...64	FLKM 10	2281018	Ribbon cable pin strip module, standard 2-level AWG: 24-12 Rating: 60 VAC, 1A	77	58.5	45.0	28.00
	FLKM 14	2281021				45.0	32.00
	FLKM 16	2281034				67.5	36.00
	FLKM 20	2281047				67.5	39.00
	FLKM 26	2281050				90.0	44.00
	FLKM 34	2281063				112.5	53.00
	FLKM 40	2281076				112.5	62.00
	FLKM 50	2281089				135.0	71.00
	FLKM 60	2281092				180.0	98.00
	FLKM 64	2281102				180.0	103.00
FLKMS 16...64	FLKMS 16	2281542	Ribbon cable pin strip module, standard 3-level AWG: 24-12 Rating: 60 VAC, 1A	77	72	45.0	43.00
	FLKMS 20	2281555				56.5	54.00
	FLKMS 26	2281568				67.5	65.00
	FLKMS 34	2281571				79.0	83.00
	FLKMS 40	2281584				79.0	95.00
	FLKMS 50	2281597				101.5	108.00
FLKMS 16...64	FLKMS 60	2281607	112.5	132.00			
	FLKMS 64	2281610	124.0	142.00			
	FLK-D25 SUB/S	2283621	D-SUB pin strip module, compact 3-level w/test connections AWG: 24-12 Rating: 125 VAC/DC, 2.5 A	51.6	51.7	71.0	65.00
FLK-D37 SUB/S	2283634	51.6		51.7	96.0	79.00	
FLK-D50 SUB/S	2283647	71.0		61.5	86.0	102.00	
FLKMS 16...64	FLK-D25 SUB/B	2283650	D-SUB socket strip module, compact standard 3-level AWG: 24-12 Rating: 125 VAC, 2.5 A	51.6	51.7	71.0	65.00
	FLK-D37 SUB/B	2283663		51.6	51.7	96.0	79.00
	FLK-D50 SUB/B	2283676		71.0	61.5	86.0	102.00
FLK-D...SUB	FLKM-D9 SUB/S	2281128	D-SUB pin strip module, standard 2-level AWG: 24-12 Rating: 125 VAC/DC, 2.5 A	77	58.5	45.0	33.00
	FLKM-D15 SUB/S	2281131				67.5	43.00
	FLKM-D25 SUB/S	2281144				90.0	48.00
	FLKM-D37 SUB/S	2281115				112.5	66.00
	FLKM-D50 SUB/S	2281157				112.5	89.00
FLK-D...SUB	FLKM-D9 SUB/B	2281186	D-SUB socket strip module, standard 2-level AWG: 24-12 Rating: 125 VAC/DC, 2.5 A	77	58.5	45.0	33.00
	FLKM-D15 SUB/B	2281199				67.5	47.00
	FLKM-D25 SUB/B	2281209				90.0	51.00
	FLKM-D37 SUB/B	2281212				112.5	66.00
	FLKM-D50 SUB/B	2281225				112.5	89.00
FLKM-D...SUB	FLKM-D9 SUB/S/LA	2281623	D-Sub pin strip module, 2-level w/light indicator AWG: 24-12 Rating: 24 VDC, 2.5 A*	77	58.5	45.0	64.00
	FLKM-D15 SUB/S/LA	2281636				67.5	81.00
	FLKM-D25 SUB/S/LA	2281649				90.0	116.00
	FLKM-D37 SUB/S/LA	2281652				112.5	157.00
	FLKM-D50 SUB/S/LA	2281665				157.5	179.00
FLKM-D...SUB	FLKM-D9 SUB/B/LA	2281678	D-Sub socket strip module, 2-level w/light indicator AWG: 24-12 Rating: 24 VDC, 2.5 A*	77	58.5	45.0	65.00
	FLKM-D15 SUB/B/LA	2281681				67.5	82.00
	FLKM-D25 SUB/B/LA	2281694				90.0	117.00
	FLKM-D37 SUB/B/LA	2281704				112.5	158.00
	FLKM-D50 SUB/B/LA	2281717				157.5	182.00

*50 position module: A=0.5

Accessories

Mfr.'s Type	Order No.	Description	Each
ES/LP-BW	1003446	25-pc. perforated blank insert labels for PMB marker carrier	.78
RPS	0201647	Test plug, for connecting a 4 mm test plug to a 2.3 mm test socket	5.45

1835

Joseph Henry invents the relay to overcome the resistance of long telegraph lines. Henry did not patent his ideas, thus setting the stage for Samuel Morse.

MCR Loop-Powered Isolator



MCR...CLP-I/I-00

- | With analog signal isolation
- | No additional supply
- | CE Mark

With these MCR (passive) loop-powered isolators, a standard signal of 0 (4) - 20 mA can be isolated, filtered and amplified in one conversion step. Since the isolator requires no external power, installation time and cost is greatly reduced. These components guarantee potential separation between the control electronics and peripherals. In addition, interference signals above 75 Hz are suppressed. These modules snap onto 35 mm wide DIN-rails and are available in 1, 2 and 4-channel versions. **Dimensions:** 99 x 114.5 x 12.5 mm (1 and 2 channel models), 99 x 114.5 x 22.5 mm (4-channel model). **Max. input:** 30 V, 100 mA. **Color:** green. **Approvals:** CE.

ules snap onto 35 mm wide DIN-rails and are available in 1, 2 and 4-channel versions. **Dimensions:** 99 x 114.5 x 12.5 mm (1 and 2 channel models), 99 x 114.5 x 22.5 mm (4-channel model). **Max. input:** 30 V, 100 mA. **Color:** green. **Approvals:** CE.

Mfr.'s Type	Order No.	Input/Output	Output Signal	Each
MCR-1CLP-I/I-00	2814016	0(4)-20 mA	1 channel	280.00
MCR-2CLP-I/I-00	2814029		2-channel	365.00
MCR-4CLP-I/I-00	2814045		4-channel	645.00

Dual Utility Outlet



General Specifications

Technical Data
 Rated voltage 120 V ac
 Rated Current 15/20 amps
 Maximum wire size #10 AWG

Housing Data
 Color Ivory
 Material PVC 94V-0
 Maximum temperature 70 °C

Dimensions
 Length 5.33 in.
 Width 3.25 in.
 Depth 2.45 in.

This outlet is fully enclosed, shock proof and the ground prongs are reversed for greater protection. It snaps onto 35 mm wide DIN-rails and can be mounted either vertically or horizontally. Screw clamp terminal block, VDFK4 provides reliable connections. Three versions are available: 15 A, 20 A, or 15 A with ground fault interruption. (GFI).

Mfr.'s Type	Order No.	Output Signal	Each
EM-DUO-120/15	5600461	Dual outlet, 15 A	35.00
EM-DUO-120/15-GFI	5600462	Dual outlet w/GFI, 15 A	58.00
EM-DUO-120/20	5600525	Dual outlet, 20 A	35.00

Compact Primary Switched-Mode Power Supply Units QUINT Series

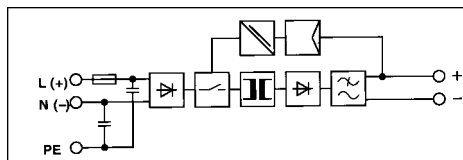
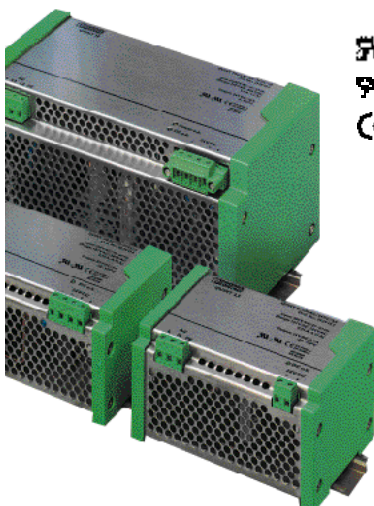

1/2.5/5/10 A Models

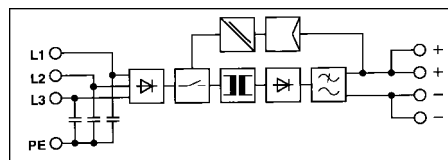

20/30/40 A Models

The **QUINT** series power supplies are industrial single voltage types with primary switched-mode regulator technology and power factor correction option. This technology means the units are lightweight and operate with a high level of efficiency. They are suitable for supplying power to electrical and electronic components in systems throughout automation engineering, plant constructions, process engineering, machine building and controller production. Connections to and from the supplies are made with **COMBICON** connectors for wiring ease.

The output is electronically protected against overload and short circuits. **Output characteristics of 1, 2.5 and 5 A units:** The units can be overloaded for approximately 80 ms without switching off. After this, the units switch off and attempt to switch back on after approximately 1 second. This process repeats itself until the short circuit on the secondary side has been eliminated. **Output characteristics of 10, 20, 30 and 40A units:** The unit cuts back the voltage if the current limit is exceeded by 10% of the nominal current and remains constant at this level. This ensures that down-circuit fuses are blown selectively.

Surge Voltage Protection: varistor. **Housing:** steel plate, sealed; sides ABS UL94V0. **Function Display:** LED. **Color:** green. **Mounting:** 35 mm wide DIN-rails.

Mfr.'s Type	Order No.	Input VAC	Output		Power Factor	AWG		Dimensions (mm)			Each										
			VDC	Amps		Input	Output	W	H	L											
QUINT-PS-120AC/24DC/1	2939247	120	24	1	0.6	24-12	24-12	107	78	87	120.00										
QUINT-PS-120AC/24DC/2.5	2939056	120		2.5	0.6		24-12	141	78	87	163.00										
QUINT-PS-120AC/24DC/2.5/F	2939250	120		2.5	0.7		24-12	141	78	87	200.00										
QUINT-PS-120AC/24DC/5	2939069	120		5	0.6		24-12	180	78	87	253.00										
QUINT-PS-120AC/24DC/5/F	2939263	120		5	0.7		24-12	180	78	87	290.00										
QUINT-PS-120AC/24DC/10	2939072	120		10	0.65		24-10	180	115	125	380.00										
QUINT-PS-120AC/24DC/10/F	2939276	120		10	0.75		24-10	180	115	125	425.00										
QUINT-PS-3X207AC/24DC/20	2939454	3x207		24	20		0.4	24-12	24-10	240	115	125	500.00								
QUINT-PS-3X207AC/24DC/20/F	2939551	3x297			20		0.8						550.00								
QUINT-PS-3X400AC/24DC/20	2939467	3x400			20		0.4						500.00								
QUINT-PS-3X400AC/24DC/20/F	2939564	3x400	20		0.8	550.00															
QUINT-PS-3X207AC/24DC/30	2939098	3x207	24		30	0.4	20-6						230	156	150	650.00					
QUINT-PS-3X207AC/24DC/30/F	2939292	3x207			30	0.7										700.00					
QUINT-PS-3X400AC/24DC/30	2939195	3x400			30	0.4										650.00					
QUINT-PS-3X400AC/24DC/30/F	2939399	3x400			30	0.7										700.00					
QUINT-PS-3X207AC/24DC/40	2939645	3x207			24	40										0.4	20-6	286	156	150	770.00
QUINT-PS-3X207AC/24DC/40/F	2939742	3x207				40										0.7					820.00
QUINT-PS-3X400AC/24DC/40	2939849	3x400		40		0.4		770.00													
QUINT-PS-3X400AC/24DC/40/F	2939946	3x400		40		0.7		820.00													

Universal Isolator/Converter



Configuration via DIPswitch

The **MCR-C-UI-UI-DCI** modules are used for isolation and conversion of analog signals. Primary applications are to provide ground loop isolation and to convert one analog signal to another.

The Universal Isolator/Converter requires a DC supply voltage of between 18 and 30 volts. A green LED on the top of the module indicates when power is applied. A 24V DC 650mA power supply, part number MCR-PS-120AC/24DC/650, is available in the same housing shape (call Carlton-Bates for details and ordering information).

Two sealed potentiometers on top allow zero/span adjustments. The unique housing provides easy access to the universal DIP switches, which allow you to change the inputs and outputs so that more than 200 signal variations are possible. The module snaps onto 35 mm wide DIN-rails. The signal and power lines are securely connected to the modules via removable COMBICON connections. **Approvals:** UL Recognized (U.S. and Canada), Class 1, Div. 2, CE. **Dimensions:** (L x H x W): 99 x 114.5 x 17.5 mm. **Max. Input:** 30 V or 50 mA. **Max. Output:** 15 V or 30 mA.

Mfr.'s Type	Order No.	Input/Output	AWG	Each
MCR-C-UI-UI-DCI...	2810913	Selectable*	24-14	275.00

*The modules will be delivered with these "standard" settings: 0-10 V/0-10 V (input/output). The user then has the option of changing the setting (via the DIP switches) to suit system requirements. Call if more details are required.

MCR Loop-Powered Isolator with Selectable Input



This loop powered isolator is used when an active or powered PLC card must interface to a 4-wire transmitter. It provides signal conversion, amplification and filtering. On the output side of the isolator, the 4-20 mA loop provides power for the module which then provides isolation and signal conversion. Two zero/span potentiometers on top allow fine adjustment of $\pm 2\%$. The signal and power lines are securely connected to the module via removable COMBICON connectors. The MCR loop-powered isolator is particularly suitable for the electrical isolation of active PLC input cards from the process peripherals. **Approvals:** CE.

Dimensions: (L x H x W): 99 x 114.5 x 17.5 mm. **Mounting:** 35 mm wide DIN-rails.

Mfr.'s Type	Order No.	Input/Output	AWG	Each
MCR-CLP-UI-I-4	2814058	Selectable*/4-20 mA	24-14	230.00

*The modules will be delivered with the "standard" settings: 4-20 mA/4-20 mA (input/output). The user then has the option of changing the input settings (via the DIPswitches) to suit system requirements. Call if more details are required.

Dip Switch Selectable

These modules convert signals from PT-100 RTD sensors and Type J or K thermocouples into electrically standardized analog signals. They are connected via insertable COMBICON plugs and include two zero/span potentiometers on top for fine adjustment of $\pm 5\%$. 2, 3 or 4-conductor connections, sensor type, cold points (thermocouples), temperature ranges and output signals are selectable via DIP switches. The desired settings can be indicated when ordering (call Carlton-Bates for ordering information). If the desired setting are not provided, the modules will be supplied with the "standard" settings shown below. **Approvals:** CE. **Dimensions (L x H x W):** 99 x 114.5 x 17.5 mm. **Mounting:** 35 mm wide DIN-rails. **AWG:** 24-14

MCR Temperature Transducers

Mfr.'s Type	Order No.	Description	Standard Settings	Each
MCR-PT-100-U/...	2810340	For PT-100, 2, 3, 4-conductor technology	0-10 V output	180.00
MCR-PT-100-I/...	2810353	For PT-100, 2, 3, 4-conductor technology	4-20 mAoutput	180.00
MCR-PT-100-U/DC/...	2810311	As above, except auxiliary power galvanically isolated	0-10 V output	227.00
MCR-PT-100-I/DC/...	2810337	As above, except auxiliary power galvanically isolated	4-20 mAoutput	227.00
MCR-TE-JK-U/...	2810531	For thermocouples type J, K	0-10 V output	200.00
MCR-TE-JK-I/...	2810544	For thermocouples type J, k	4-20 mAoutput	200.00
MCR-TE-JK-U-E/...	2810515	As above except with isolated input	0-10 V output	270.00
MCR-TE-JK-I-E/...	2810528	As above except with isolated input	4-20 mAoutput	270.00

MCR Loop-Powered Isolator



MCR...CLP-1/1-00

- | With analog signal isolation
- | No additional supply
- | CE Mark

With these MCR (passive) loop-powered isolators, a standard signal of 0 (4) - 20 mA can be isolated and filtered in one module. Since the isolator requires no external power, installation time and cost is greatly reduced. These components guarantee potential separation between the control electronics and process peripherals.

In addition, EMI/RFI interference is suppressed. These modules snap onto 35 mm wide DIN-rails and are available in 1, 2 and 4-channel versions. **Dimensions:** 99 x 114.5 x 12.5 mm (1 and 2 channel models), 99 x 114.5 x 22.5 mm (4-channel model). **Max.Input:** 30 V, 120 mA. **Color:** green. **Approvals:** CE.

Mfr.'s Type	Order No.	Input/Output	Output Signal	Each
MCR-1CLP-I/I-00	2814016	0 (4) - 20 mA	1-channel	200.00
MCR-2CLP-I/I-00	2814029		2-channel	365.00
MCR-4CLP-I/I-00	2814045		4-channel	645.00

MCR Programmable Temperature Transducers for RTDs and Thermocouples



MCR-T-UI/

The programmable MCR-T module converts and isolates temperature signals from resistance thermometers (RTDs), thermocouples and sensors with linear mV characteristics into standard industrial analog signals. The module, which has an electronic switching PNP transistor output (100 mA/24V), is factory-configured for thermocouple sensors and RTDs in 2, 3, or 4-wire systems. The configuration, (which includes characteristic curve connection system, lower and upper measurement ranges, unit of measure and output), **must be specified** when ordering. The output options are 0-20 mA, 4-20 mA, 0-5 V, 0-10V, ± 5 V or ± 10 V. Call Carlton-Bates for

complete ordering information. **Approvals:** CE, UL, Class 1, Div. 2. **Dimensions: (L x H x W):** 99 x 114.5 x 17.5 mm. **Mounting:** 35 mm wide DIN-rails.

Mfr.'s Type	Order No.	Configuration	AWG	Each
MCR-T-UI-E	2814113	Specify	24-14	299.00



MCR-PT-100-

Data Interface Converters and Isolators

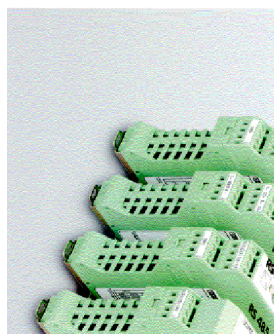

Industrial data conversion needs industrial, not office grade converters. These isolators and converters feature 2000V electrical isolation and surge suppression, built in as standard. The modules are DIN-rail mountable and require 24VDC power. Cable shielding is maintained and removable wire terminal blocks reduce installation time. DIP switches allow customization for specific applications. **Approvals:** CE, UL, Class 1. Div. 2. **Dimensions (LxHxW):** 99x119x22.5mm.

Mfr.'s Type	Order No.	Description	Each
PSM-ME-RS485/RS485-P	2744429	RS485 repeater for MODBUS, PROFIBUS and others	330.00
PSM-ME-RS232/RS232-P	2744461	Isolator for RS232 systems	300.00
PSM-ME-RS485/TTY-P	2744458	Converter for RS 232 to TTY protocol	300.00
PSM-ME-RS232/RS485-P	2744416	Converter for RS 232 to RS485 equipment	300.00

SUBCON Field Bus Connectors



The SUBCON D-SUB connectors (with screw connection) can be connected quickly and conveniently in the field without soldering or crimping tools. The plug-in contacts are connected to clearly numbered screw terminals blocks. The 9-position version is especially suited to INTERBUS and a special version with terminating resistor is available for PROFIBUS. Both male and female connectors are available in 9, 15 and 25-pin versions. **AWG:** 26-16

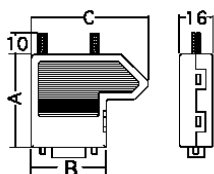

Varioface Modules for Solid-State Relays



These modules allow for DIN-rail mounting of standard solid state relays in a high density, self-contained package. The screw terminal blocks on both sides of the module can hold a wide range of conductor sizes (AWG 26-14). It is available for screw-down mounting of 1, 2 or 4 relays. A fuse and indicator for each relay is located on the base. The relays are ordered separately. Call Carlton-Bates for details. **Rating:** 250 VDC, 5 A. **Dimensions (Lx H):** 77 x 40.6 mm.

Mfr.'s Type	Order No.	Description	Dimensions (mm)			Each
			A	B	C	
SUBCON 9/F-SH	2761499	9-pin female	44.5	36.0	56.4	41.00
SUBCON 9/M-SH	2761509	9-pin male	44.5	36.0	56.4	41.00
SUBCON 15/F-SH	2761596	15-pin female	44.5	44.3	64.7	45.00
SUBCON 15/M-SH	2761606	15-pin male	44.5	44.3	64.7	45.00
SUBCON 25/F-SH	2761619	25-pin female	49.5	58.0	78.7	50.00
SUBCON 25/M-SH	2761622	25-pin male	49.5	58.0	78.7	50.00
SUBCON PLUS PROFIB	2744348	PROFIBUS	44.0	36.0	60.0	35.00

Mfr.'s Type	Order No.	Description	Width (mm)	Each
FLKM-I/O	2282075	Module for 1-relay	45.0	18.00
FLKM-2-I/O	2282088	Module for 2-relays	67.5	28.00
FLKM-4-I/O	2282091	Module for 4-relays	135.0	52.00

Varioface Modules for Interface Relays

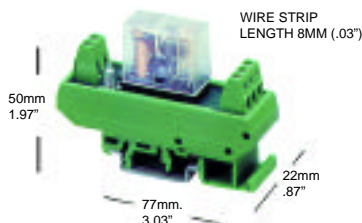

Interface relays are used in industrial applications where low-capacity input control signals control high-capacity output signals. The two-position changeover version allows a load resistor to be switched with one single control signal. The DC versions are provided with an LED status indicator and contain a damping diode to protect the control circuit. With the AC versions, the switching status is indicated with a glow lamp and does not have a damping diode. The relay supplied with the units is SPDT, hermetically encapsulated with 10 A contacts. **AWG:** 26-14. **Rating:** determined by the relay. **Mounting:** 35 mm wide DIN-rail.

Mfr.'s Type	Order No.	Input Volts	Description	Each
UMK22-REL 24/21-ST	5520695	24 VDC	Single position change-over switch, w/light indicator and damping diode	27.00
UMK22-REL 120/21-ST	5520705	120 VAC	As above, except with glow lamp, without damping diode	35.00
UMK22-REL 24/21-21-ST	5520734	24 VDC	Two-position change-over switch, w/light indicator and damping diode	35.00
UMK22-REL 120/21-21-ST	5520721	120 VAC	As above, except with glow lamp, without damping diode	41.00

Call for quantity pricing!

1800

Alessandro Volta develops the battery, the first source of continuous electric current. It consisted of a number of copper and zinc discs arranged alternately in a vertical stack, separated by paper moistened in acid. The practical unit of potential difference, the volt, is named for Volta.

PLC Protector MAINS-MODUTRAB



The MAINS-MODUTRAB mounts on standard DIN-rails and interfaces with terminal blocks to provide surge voltage protection for single-phase power supplies. Features a thermal detection device, which disconnects the protection path from the power supply in the event of varistors overheating. Includes two indicator lamps: green monitors input voltage; red indicates power to the source has been disconnected. Black, enclosed housing is rated IP20. Also available without light indicators (MT...OLA).

Mfr.'s Type	Order No.	Input Voltage	AWG	Each
With light indicators				
MT-2PE/S-24AC	2748072	24V AC/DC	24-12	90.00
MT-2PE/S-60AC	2748085	60 V AC/DC		90.00
MT-2PE/S-120AC	2788935	120 V AC/DC		96.00
MT-2PE/S-230AC	2798802	230 V AC/DC		96.00
Without light indicators				
MT-2PE/S-120AC-OLA	1788948	120 V AC/DC	24-12	75.00
MT-2PE/S-230AC-OLA	2788757	230 V AC/DC		75.00

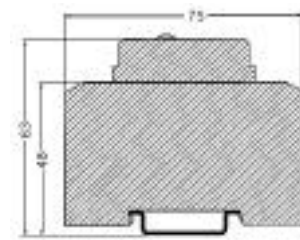

Housing width: 50 mm

24 VDC I/O Signal Protection TERMITRAB

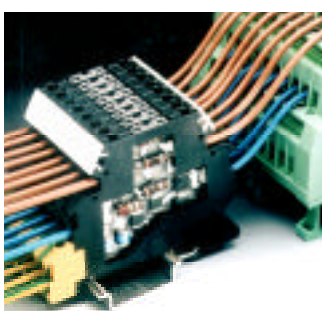

TERMITRAB provides 3 stage protection (diode, MOV, gas tube) for 24 VDC signals. The narrow 6.2mm housing provides high density protection and is rated for 5000 amps of 8 x 20 Msecond surge current. The analog model protects one loop while the digital model protects two digital signals. Grounding is accomplished via a metal grounding foot. IP20 housing, accepts wire sizes 24 AWG to 18 AWG, CE approved.

Mfr.'s Type	Order No.	Description	Each
TT-2PE-24DC	2838186	Analog (4-20mA, 0-10 VDC)	74.00
TT-2/2-24DC	2838173	Digital signal protection	79.15

Surge Protection for Conduit Systems SURGETRAB

The surge protector **SURGETRAB-S-PT1-2PE-24DC** is designed specifically for installation in conduit systems. The protective circuit is on a small PCB housed inside a 4.72" long pipe with two 3/4" threaded ends. The pipe has a screw cover on one end, and, with a T-adaptor, this device can be integrated into any conduit system. The 2-stage protective circuit provides protection for conductor pairs in floating signal circuits. A powerful gas-filled 3-electrode surge arrester and a low limiting diode are decoupled by resistors, providing both fine and coarse protection. Two terminal blocks on the PCB clearly marked "IN" and "OUT" provide secure connections. The PCB grounding wire is connected to a washer on one end of the pipe. The ground is completed when the pipe screw cover is tightened. **Nominal voltage:** 24 VDC. **Max. voltage:** 28 VDC. **Nominal Current:** 250 mA. **AWG:** 26-16. **Max. response time:** normal mode, 1 ns; common mode, 100ns.

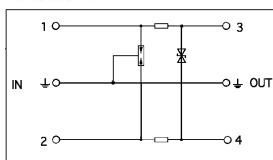

Mfr.'s Type	Order No.	Description	Each
S-PT1-2PE-24DC	2818122	Pipe stub w/integrated PCB	85.00
S-PT1-2PE-24DC/P	2818216	PCB only without pipe stub	48.00

Phoenix Surge Voltage Protection TRABTECH (Transient Absorption Technology) — The All-round Protection Concept

- Lightning Current Arresters and Mains Surge Voltage Protection
- Surge Voltage Protection for Data Interfaces
- Surge Voltage Protection for Special Applications
- Surge Voltage Protection Analog Digital I/O
- Telecommunication Protection
- Material for Equipotential Bonding and TRABTECH Housings
- Testers

VARIOCON is a range of modular plug connectors designed for industrial applications. Each connector set consists of the following components: either a plastic or metal hood, hood frame, panel mounting frame, panel mounting flanges, marker tag and shield adapter (for EMC series). The modular contact inserts must be ordered separately and are listed below.

Three series, with four housing sizes each are available, and feature IP 65-IP 69K protection, and can be either PCB or panel mounted. The plastic housings are made of high-impact industrial plastic and can withstand most mechanical and chemical influences. The corrosion resistant metal housings are made of tin and copper-plated zinc die casts. The hoods of all the series have the same shape and dimensions. Two screws ensure a tight connection. Optional glands are listed below.



Mfr.'s Type	Order No.	Hood Size	Description	For Number of Modules	Hood Dimensions (mm)				Each
					A	B	C	D	
VC-K1/2M-SET	1854116	1	Connector set, plastic series	2	73.3	64.8	59	66	20.59
VC-K2/3M-SET	1854145	2		3	72.2	64.8	74	81	22.83
VC-K3/4M-SET	1854187	3		4	79.3	74.9	89	96	24.63
VC-K4/5M-SET	1854226	4		5	76.3	75.0	104	111	27.79
VC-M1/2M-SET	1854268	1	Connector set, metal series	2	73.3	64.8	59	66	34.57
VC-M2/3M-SET	1854284	2		3	72.2	64.8	74	81	39.51
VC-M3/4M-SET	1853780	3		4	79.3	74.9	89	96	41.45
VC-M4/5M-SET	1854310	4		5	76.3	75.0	104	111	46.13
VC-EMV1/2M-SET	1854336	1	Connector set, metal, shielded EMC series	2	73.3	64.8	59	66	37.90
VC-EMV2/3M-SET	1854352	2		3	72.2	64.8	74	81	43.69
VC-EMV3/4M-SET	1854378	3		4	79.3	74.9	89	96	46.29
VC-EMV4/5M-SET	1854381	4		5	76.3	75.0	104	111	52.06

Modular Contact Inserts

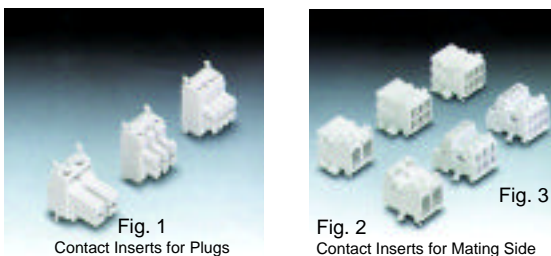

These modular contact inserts are based on proven COMBICON technology and are available in three versions. The inserts for the plug connector sets above snap into the mounting frame and can be inserted quickly into the hood. They feature screw connections and socket contacts. The contact inserts for the mating side feature pin contacts and are available in PCB or panel mount options. The panel mount inserts are like the PCB inserts except they are connected via screw terminal blocks. All three versions are 15 mm wide and are offered with 2, 6 or 8 positions. The individual contacts can be keyed with optional key tabs, preventing mismatching when several connectors are in close proximity. Approvals: UL recognized (U.S. and Canada).

Mfr.'s Type	Order No.	Fig.	No. of Pos.	Description	Pitch (mm)	AWG	Rating	Each
VC-TFS-2	1852846	1	2	Contact insert for plug connector	7.5	24-10	400V, 20A	3.85
VC-TFS-6	1853476		6		5.0	28-16	250V, 8A	5.37
VC-TFS-8	1852820		8		3.5	28.16	125V, 8A	7.23
VC-AML-2	1852859	2	2	Contact insert for mating side-PCB mount	7.5	...	400V, 20A	3.07
VC-AML-6	1853531		6		5.0	...	250V, 8A	3.83
VC-AML-8	1852833		8		3.5	...	125V, 8A	6.28
VC-AMS-2	1853528	3	2	Contact insert for mating side-panel mount	7.5	24.10	400V, 20A	3.41
VC-AMS-6	1854019		6		5.0	28.16	250V, 8A	5.00
VC-AMS-8	1854022		8		3.5	28.16	125V, 8A	7.16
CP-HCC 4	1600027	Keytabs, red, 100 pc. pkg., for all 2-pos. contact inserts						5.00/pkg.
CP-MSTB	1734634	Keytabs, red, 100 pc. pkg., for VC-AM6, VC-AML8, VC-AMS6, VC-AMS8						5.00/pkg.

Cable Glands



Cable glands made of plastic, metal and metal/shielded are available. Plastic and metal glands consist of a rubber seal and pressure screw, which also serves as a strain relief. The shielded version, used with the EMC series connectors, also includes an iris spring and two conical washers, that slip over and contact the braided shielding.

Mfr.'s Type	Order No.	Cable Dia. (mm)	Description	Each
VC-K-KV-PG16 (4-6.5)	1854459	4-6.5	Plastic series for size 1 hoods	3.19
VC-K-KV-PG16 (5-8)	1853735	5-8		
VC-K-KV-PG16 (6.5-9.5)	1853748	6.5-9.5		
VC-K-KV-PG16 (7-10.5)	1853751	7-10.5		
VC-K-KV-PG16 (9-13)	1853764	9-13		
VC-K-KV-PG16 (11.5-15.5)	1854844	11.5-15.5		
VC-K-KV-PG21 (7-10.5)	1853890	7-10.5	Plastic series for sizes 2-4 hoods	5.25
VC-K-KV-PG21 (9-13)	1853900	9-13		
VC-K-KV-PG21 (11.5-15.5)	1853913	11.5-15.5		
VC-K-KV-PG21 (14-18)	1853926	14-18		
VC-K-KV-PG21 (17-20.5)	1853939	17-20.5		
VC-M-KV-PG16 (4-6.5)	1853942	4-6.5	Metal series for size 1 hoods	4.18
VC-M-KV-PG16 (5-8)	1853955	5-8		
VC-M-KV-PG16 (6.5-9.5)	1953968	6.5-9.5		
VC-M-KV-PG16 (7-10.5)	1853971	7-10.5		
VC-M-KV-PG16 (9-13)	1853984	9-13		
VC-M-KV-PG16 (11.5-15.5)	1854857	11.5-15.5		

Mfr.'s Type	Order No.	Cable Dia. (mm)	Description	Each
VC-M-KV-PG21 (7-10.5)	1853997	7-10.5	Metal series for size 2-4 hoods	7.59
VC-M-KV-PG21 (9-13)	1854006	9-13		
VC-M-KV-PG21 (11.5-15.5)	1854035	11.5-15.5		
VC-M-KV-PG21 (14-18)	1854048	14-18		
VC-M-KV-PG21 (17-20.5)	1854051	17-20.5		
VC-EMV-KV-PG16 (6.5-9.5/6.5)	1854132	6.5-9.5	Metal shielded series for size 1 hoods	16.93
VC-EMV-KV-PG16 (7-10.5/8.5)	1854161	7-10.5		
VC-EMV-KV-PG16 (9-13/10.5)	1854174	9-13		
VC-EMV-KV-PG21 (9-13/9.5)	1854200	9-13	Metal shielded series for size 2-4 hoods	22.55
VC-EMV-KV-PG21 (9-13/12)	1854213	9-13		
VC-EMV-KV-PG21 (11.5-15.5/13.5)	1854242	11.5-15.5		
VC-EMV-KV-PG21 (14-18/14.5)	1854255	14-18		

Note (metal shielded series): The cable shield dia. is indicated in the part number. For example, VC-EMC-KV-PG21 (9-13/12), the /12 indicates a cable shield dia of 12 mm.

Features of the INTERBUS ST Module

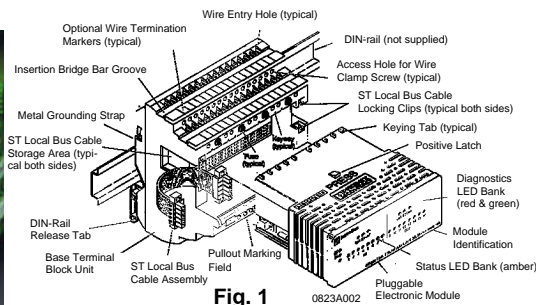

Fig. 1

The INTERBUS ST (Smart Terminal Block) family of products is a compact class of I/O modules that communicates over an INTERBUS sensor/actuator network. Components and assemblies that make up the module are identified in Figure 1. The three main structural components are the DIN-rail mounted base terminal block unit, pluggable electronics module and the STlocal bus cable assembly. The base terminal block unit contains the wire-clamp assemblies, connectors and fuses. The electronics module contains all the actual circuitry.



Mfr.'s Type & Order No.	Description	I/O Data
-------------------------	-------------	----------

Bus Terminal Modules - Copper and Fiber Optic

IBS ST 24 BKM-T 2750154	Bus Terminal Module with fixed electronics: copper remote bus, COMBICON remote bus connection.	Not Applicable
IBS ST 24 BK-T 2754341	Bus Terminal Module: copper remote bus, 9-pin D-Sub remote bus connection.	Not applicable
IBS ST 24 BK RB-T 2753504	Bus Terminal Module: copper remote bus, 9-pin D-Sub remote bus connection, 9-pin branch remote bus connection.	Not Applicable
IBS ST 24 BK LB-T 2753232	Bus Terminal Module: copper remote bus, 9-pin D-Sub remote bus connection, plus an additional 15-pin D-Sub local bus connection.	Not Applicable
IBS ST 24 BK DIO 8/8/3-T 2752411	Bus Terminal Module with I/O: copper remote bus, 9-pin D-Sub remote bus connection, FLK connection.	8 inputs: 24 VDC, 5 mA, 1ms filter. 8 outputs: 24 VDC, 0.5 A.
IBS ST 24 BKM-LK 2750963	Bus Terminal Module with fixed electronics: fiber optic remote bus, FSMARemote bus connection.	Not Applicable
IBS ST 24 BK-LK 2754435	Bus Terminal Module: fiber optic remote bus, FSMARemote bus connection.	Not Applicable
IBS ST 24BK DIO 8/8/3-LK 2751218	Bus Terminal Module with I/O: fiber optic remote bus, FSMA remote bus connection, FLK connection.	8 inputs: 24 VDC, 5 mA, 1ms filter. 8 outputs: 24 VDC, 0.5 A.
IBS ST 24 BK RB-T DIO 8/8/3-LK 2723453	Bus Terminal Module with I/O: fiber optic remote bus, FSMA remote bus connection, 9-pin branch remote bus connection, FLK connection.	8 inputs: VDC, 5 mA, 3 ms filter 8 outputs: 24 VDC, 0.5 A.
IBS ST 24 BK RB-LK DIO 8/8/3-LK 2721662	Bus Terminal Module with I/O: fiber optic remote bus, FSMA remote bus connection, FSMA branch remote bus connection, FLK connection.	8 inputs: 24 VDC, 5 mA, 3 ms filter. 8 outputs: 24 VDC, 0.5 A.

Analog Input Modules

IB ST 24 BAI 8/U 2721015	Analog Input Module: 24 VDC, 8 voltage inputs (single ended).	Configurable per channel. Voltage ranges: 0 to +5 VDC, 0 to +10 VDC, 0 to +25 VDC, 0 to +50 VDC, 8- or 12- bit resolution modes (39 or 2.44 mV/step).
IB ST 24 BAI 2/SF 2722771	Analog Input Module: 24 VDC, 2 voltage or current inputs (differential).	Voltages range: 0 to +10 VDC (2.44 mV/step). Current ranges: 0 to +20 mA(4.88 µA/step), +4 to +20 mA (3.91 µA/step). 12-bit resolution.
IB ST 24 AI 4/SF 2754309	Analog Input Module: 24 VDC, 4 voltage or current inputs (differential).	Voltage range: 0 to +10 VDC (2.44 mV/step). Current ranges: 0 to +20 mA(4.88 µA/step). 12-bit resolution.
IB ST 24 AI 4/SF4 2750565	Analog Input Module: 24 VDC, 4 voltage or current inputs (differential).	Voltage range: 0 to +10 VDC (4.88 mV/step). Current ranges: +4 to +20 mA(3.91µA/step). 12-bit resolution.
IB ST 24 BAI 2/BP 2725888	Analog Input Module: 24 VDC, 2 voltage or current inputs (differential).	Voltage range: -10 to +10 VDC (4.88 mV/step). Current ranges: -20 to +20 mA(9.75 µA/step). 12- bit resolution.
IB ST 24 AI 4/BP 2751564	Analog Input Module: 24 VDC, 4 voltage or current inputs (differential).	Voltage range: -10 to +10 VDC (4.88 mV/step). Current ranges: +4 to +20 mA(7.81 µA/step). 12- bit resolution.
IB ST 24 AI 4/I 2719629	Analog Input Module: 24 VDC, 4 voltage or current inputs (differential and isolated per channel).	Configurable per channel. Voltage: 0 to +10 VDC (2.44 mV/step). Current: 0 to +20 mA(4.88 µA/step), +4 to +20 mA(3.91 µA/step). 12- bit resolution.
IB ST 24 BAI 8/I 2721028	Analog Input Module: 24 VDC, 8 current inputs (single ended).	Configurable per channel. Current ranges: 0 to +20 mA, +4 to +20 mA, 0 to +40 mA, 0 to +60 mA, 8-bit (62.7 µA/step) or 12- bit (3.9 µA/step) resolution.
IB ST 24 PT 100 4/4 2752767	Analog Input Module: 24 VDC, 4 RTD inputs.	Measuring range: -273.1 to +3276.7°C or -459.6 to +3276.7°F. 16-bit resolution: 0.1°C or 0.1 K for Celsius, 0.1°F or 0.056 K for Fahrenheit.
IB ST 24 UTH 8 2724902	Analog Input Module: 24 VDC, 8 thermocouple inputs.	J- or K-type thermocouples. 16-bit resolution.
IB ST 24 BAI 8/U-MV 2724986	Analog Input Module: 24 VDC, 8 voltage inputs (single ended).	Configurable per channel. Voltage ranges: 0 to +100, 0 to +200, 0 to +500 mVDC. Also 0 to +1 VDC. Resolution: 8- or 12- bit (781.25 or 48.83 µV/step).

(Continued on

Process understanding is the key to choosing the correct I/O modules. The ST table below is organized to help you find the modules that meet your control needs. After choosing those modules that meet your current and future requirements, you will have to determine the complimentary products and accessories needed to complete your system. A list of accessories is provided with each module data sheet. Data sheets are available for most modules and may be obtained through Phoenix Contact's FAX-ON-DEMAND system (800-944-9901) or calling Carlton-Bates. **Connection Data:** AWG 24-12.

Operating Temperature: 0 to +55° C. Wide temperature range modules (-20° to +55° C) are available upon request.

Features



Electronics packaged in a removable module
 Pullout marking field for channel identification on most modules
 Optional wire termination markers available.
 Screw-clamp terminations for both module power and I/O power.
 Spring-clamp terminations are available for most modules upon request.
 Electrical isolation
 IP20 housing rating

I/O modules accept 2, 3- or 4-wire I/O devices, depending on module type
 I/O modules have from 2 to 32 I/O points depending on module type.
 Each local bus can support up to 256 I/O points
 Each local bus can support both digital and analog signals
 Diagnostic and status LEDs on each module
 Module diagnostics over INTER-BUS network.

Features	Power Requirements	Local Bus Current	Dimensions W x H x D	Each
Slim design. Network connectors included. Supports up to four ST local bus I/O modules (observe local bus current capacity).	24 VDC 350 mAmax.	500 mAmax. supply	44 x 116 x 117 (mm)	190.00
Alarm output. Reconfiguration input. Supports up to eight ST local bus I/O modules (observe local bus current capacity).	24 VDC 650 mAmax.	800 mAmax. supply	81 x 116 x 117 (mm)	340.00
Alarm output. Reconfiguration input. Supports up to eight STlocal bus I/O modules (observe local bus current capacity). Provides two remote bus outputs.	24 VDC 650 mAmax.	800 mAmax. supply	81 x 116 x 117 (mm)	550.00
Alarm output. Reconfiguration input. Supports up to eight STor Flat Pack local bus I/O modules (observe local bus current capacity).	24 VDC 650 mAmax.	800 mAmax. supply	81 x 116 x 117 (mm)	550.00
Reconfiguration input. Supports up to four ST local bus I/O modules (observe local bus current capacity). Accepts two- and three-wire I/O devices.	24 VDC 450 mAmax.	500 mAmax. supply	118 x 116 x 117 (mm)	680.00
Slim design. Supports up to four STlocal bus I/O modules (observe local bus current capacity). Electrical isolation between communication and supply voltage.	24 VDC 300 mAmax.	500 mAmax. supply	44 x 116 x 117 (mm)	680.00
Alarm output. Reconfiguration input. Supports up to eight STlocal bus I/O modules (observe local bus current capacity).	24 VDC 350 mAmax.	800 mAmax. supply	81 x 116 x 117 (mm)	298.00
Reconfiguration input. Supports up to four ST local bus I/O modules (observe local bus current capacity). Accepts two- and three-wire I/O devices.	24 VDC 450 mAmax.	500 mAmax. supply	118 x 116 x 117 (mm)	430.50
Reconfiguration input. Supports up to four ST local bus I/O modules (observe local bus current capacity). Accepts two- and three-wire devices. Provides two remote bus outputs.	24 VDC 500 mAmax.	500 mAmax. supply	118 x 116 x 117 (mm)	798.00
Reconfiguration input. Supports up to four ST local bus I/O modules (observe local bus current capacity). Accepts two-and three-wire I/O devices. Provides two remote bus outputs.	24 VDC 500 mAmax.	500 mAmax. supply	118 x 116 x 117 (mm)	980.00
Process data update time: 350 µs/channel. Fault indication: failure of +24 V I/O supply voltage, failure of ±15 V or +5 V I/O voltage, blown fuse at I/O supply voltage.	24 VDC 68 mAtyp. (no passive sensors) 160 mAtyp. (at max. load)	135 mAmax. draw	118 x 116 x 117 (mm)	825.00
Process data update time: 0.55 ms/channel.	24 VDC	140 mAmax. draw	81 x 116 x 117 (mm)	450.00
Process data update time: .075 ms/channel. Fault indication: failure of +24 V I/O supply voltage, failure of ±15 V or +5 V I/O voltage, blown fuse at I/O supply voltage.	24 VDC 125 mAtyp. (no passive sensors) 300 mAtyp. (at max. load)	150 mAmax. draw	118 x 116 x 117 (mm)	820.00
Process data update time: 0.75 ms/channel. Fault indication: failure of +24 V I/O supply voltage, failure of ±15 V or +5 V I/O voltage, blown fuse at I/O supply voltage.	24 VDC 125 mAtyp. (no passive sensors) 300 mAtyp. (at max. load)	150 mAmax. draw	118 x 116 x 117 (mm)	815.00
Process data update time: 0.55 ms/channel.	24 VDC	140 mAmax. draw	81 x 116 x 117 (mm)	450.00
Process data update time: 1 ms/channel. Fault indication: failure of +24 V I/O supply voltage, failure of +15 V or +5 V I/O voltage, blown fuse at I/O supply voltage.	24 VDC 125 mAtyp. (no passive sensors) 300 mAtyp. (at max. load)	150 mAmax. draw	118 x 116 x 117 (mm)	925.00
Process data update time: 0.55 ms/channel. Fault indication: failure of +24 V I/O supply voltage, failure of ±15 V or +5 V I/O voltage, blown fuse at I/O supply voltage.	24 VDC 80 mAmax.	100 mAmax. draw	118 x 116 x 117 (mm)	1110.00
Process data update time: 0.4 ms/channel. Fault indication: failure of +24 V I/O supply voltage, failure of ±15 V or +5 V I/O voltage, blown fuse at I/O supply voltage.	24 VDC 68 mAtyp. (no passive sensors) 160 mA(at max. load)	150 mAmax. draw	118 x 116 x 117 (mm)	830.00
Process data update time: 258 ms/channel.	24 VDC 65 mAmax.	100 mAmax. draw	118 x 116 x 117 (mm)	780.00
Process data update time: 3 s/channel.	24 VDC 65 mAmax.	150 mAmax. draw	118 x 116 x 117 (mm)	1000.00
Process data update time: 350 µs/channel. Fault indication: failure of +24 V I/O supply voltage, failure of ±15 V or +5 V I/O voltage, blown fuse at I/O supply voltage.	24 VDC 68 mAtyp. (no passive sensors) 160 mAtyp. (at max. load)	135 mAmax. draw	118 x 116 x 117 (mm)	1250.00

next page)

Mfr.'s Type & Order No.	Description	I/O Data
Digital Input Modules		
IB ST 24 DI 32/2 2754927	Digital Input Module: 24 VDC, 32 inputs. Accepts two-wire I/O devices.	32 inputs, 24 VDC, 5 mA, 3ms filter
IB ST 24 BDI 8/4 2750808	Digital Input Module: 24 VDC, 8 inputs. Accepts two-, three-, and four- wire I/O devices.	8 inputs, 24 VDC, 6 mA, 0 ms filter
IB ST 24 BDI 16/4 2750170	Digital Input Module: 24 VDC, 16 inputs. Accepts two-, three-, and four- wire I/O devices.	16 inputs, 24 VDC, 6 mA, 0 ms filter
IB ST 24 DI 16/4 2754338	Digital Input Module: 24 VDC, 16 inputs. Accepts two-, three-, and four- wire I/O devices	16 inputs, 24 VDC, 7 mA, 3 ms filter
IB ST 48 DI 16/2 2721109	Digital Input Module: 48 VDC, 16 inputs. Accepts two- wire I/O devices.	16 inputs, 48 VDC, 7 mA, 3 ms filter
IB ST 120 DI 16/3 2719276	Digital Input Module: 120 VAC, 16 inputs. Accepts two- and three- wire I/O devices.	16 inputs, 120 VAC, 4.8 mA, 30 ms filter
IB ST 230 DI 16/3 2721099	Digital Input Module: 230 VAC, 16 inputs. Accepts two- and three- wire I/O devices.	16 inputs, 230 VAC, 7 mA, 30 ms filter

Digital Input and Output Modules

IB ST 24 DIO 8/8/3-2A 2753708	Digital Input/Output Module: 24 VDC, 8 inputs, 8 outputs. Accepts three-wire I/O devices.	8 inputs: 24 VDC, 5 mA, 3 ms filter. 8 outputs: 24 VDC, 2.0 A.
IB ST 24 DIO 8/8/3-2A-S 2753449	Digital Input/Output Module: 24 VDC, 8 inputs, 8 outputs with output logic control. Accepts three- wire I/O devices.	8 inputs: 24 VDC, 5 mA, 3 ms filter. 8 outputs: 24 VDC, 2.0 A.
IB ST 24 DIO 8/8R/3 2751849	Digital Input/Output Module: 24 VDC, 8 inputs, 8 relay outputs (SPDT). Accepts three- wire I/O devices.	8 inputs: 24 VDC, 5 mA, 3 ms filter. 8 relay outputs (SPDT): up to 230 VAC and 3.0 A.

Digital Output Modules

IB ST 24 BDO 32/2 2750824	Digital Output Module: 24 VDC, 32 outputs. Accepts two- wire I/O devices.	32 outputs: 24 VDC, 0.5 A.
IB ST 24 DO 32/2 2754325	Digital Output Module: 24 VDC, 32 outputs. Accepts two- wire I/O devices.	32 outputs: 24 VDC, 0.5 A.
IB ST 24 BDO 8/3 2750811	Digital Output Module: 24 VDC, 8 outputs. Accepts two- and three- wire I/O devices.	8 outputs: 24 VDC, 0.25 A.
IB ST 24 BDO 16/3-250 2750167	Digital Output Module: 24 VDC, 16 outputs. Accepts two- and three- wire I/O devices.	16 outputs: 24 VDC, 0.25 A.
IB ST 24 BDO 16/3-500 2724931	Digital Output Module: 24 VDC, 16 outputs. Accepts two- and three- wire I/O devices.	16 outputs: 24 VDC, 0.5 A.
IB ST 24 DO 16/3 2754914	Digital Output Module: 24 VDC, 16 outputs. Accepts two- and three- wire I/O devices.	16 outputs: 24 VDC, 0.5 A.
IB ST 24 DO 16 R/S 2721112	Digital Output Module: 24 VDC, 16 relay outputs (SPST). Accepts two- and three- wire I/O devices.	16 relay outputs (SPST): up to 230 VAC and 3.0 A.
IB ST 24 DO 8/3-2A 2754891	Digital Output Module: 24 VDC, 8 outputs. Accepts two- and three- wire I/O devices.	8 outputs: 24 VDC, 2.0 A.
IB ST 120/230 DO 8/3-1A 2719263	Digital Output Module: 120 or 230 VAC, 8 outputs. Accepts two- and three- wire I/O devices.	8 outputs: 120 or 230 VAC, 1.0 A.

Analog Output Modules

IB ST 24 BAO 8/U-8B 2721031	Analog Output Module: 24 VDC, voltage outputs.	Voltage range: 0 to +10 VDC (39 mV/step), 8- bit resolution.
IB ST 24 AO 4/BP 2752521	Analog Output Module: 24 VDC, 4 voltage outputs.	Voltage range: -10 to +10 VDC (4.88 mV/step), 12- bit resolution
IB ST 24 BAO 8/U 2721044	Analog Output Module: 24 VDC, 8 voltage outputs.	Voltage range: -10 to +10 VDC (2.44 mV/step) or -12 to +12 VDC (2.93 mV/step). 13- bit resolution.
IB ST 24 AO 4/SF 2754312	Analog Output Module: 24 VDC, 4 voltage or current outputs.	Voltage range: 0 to +10 VDC (2.44 mV/step). Current range: 0 to +20 mA(4.88 µA/step). 12 bit- resolution.
IB ST 24 AO 4/SF4 2750578	Analog Output Module: 24 VDC, 4 voltage or current outputs.	Voltage range: 0 to +10 VDC (2.44 mV/step). Current range: +4 to +20 mA(3.91 µA/step). 12- bit resolution.

Special Function modules

IB ST V.24 2725480	RS-232/V.24 Communication Module	Configurable baud rate (110 to 19200) via PCP channel.
IB ST 24 CNT 2750400	Counter Modules with 4 Counters	16- bit resolution, pulse generator .01 to 10 kHz. Measuring range: 0 to 90 kHz (typ), 0 to 300 kHz (with one channel in use).
IB ST 24 INC/2 2751975	Two-channel Positioning Module	Incremental encoder inputs: 0 to 25 kHz (24 V sig- nals), 0 to 500 kHz (5V signals). Refer to module data sheet no. 0614 for more information.

Modules

Module Family (continued)



Features	Power Requirements	Local Bus Current	Dimensions (W x H x D)	Each
One isolated group. Fault indication: failure of +24 V I/O supply voltage	24 VDC 2.0 A	100 mAmax. draw	118 x 116 x 117 (mm)	525.00
One isolated group. Fault indication: failure of +24 V I/O supply voltage, blown fuse at I/O supply voltage	24 VDC 200 mA	50 mA max. draw	81 x 116 x 117 (mm)	210.00
One isolated group. Fault indication: failure of +24 V I/O supply voltage failure, blown fuse at I/O supply voltage	24 VDC 1.0A	100 mAmax. draw	118 x 116 x 117 (mm)	245.00
Four isolated groups. Fault indication: failure of +24 V I/O supply voltage, short circuit or overload of initiator supply voltage, over-temperature of an output driver.	24 VDC 800 mA	100 mAmax. draw	118 x 116 x 117 (mm)	320.00
One isolated group.	48 VDC	100 mAmax. draw	118 x 116 x 117 (mm)	480.00
One isolated group.	120 VAC 1.0A	100 mAmax. draw	118 x 116 x 117 (mm)	385.00
One isolated group.	230 VAC	100 mAmax. draw	118 x 116 x 117 (mm)	480.00

Fault indication: blown fuse at I/O supply voltage (indicated only is the other fuse in isolated group is OK).	24 VDC 16 A max.	100 mAmax. draw	118 x 116 x 117 (mm)	505.00
Fault indication: blown fuse at I/O supply voltage (indicated only is the other fuse in isolated group is OK).	24 VDC 16 A max.	100 mAmax. draw	118 x 116 x 117 (mm)	650.00
	24 VDC	100 mAmax. draw	118 x 116 x 117 (mm)	400.00

One isolated group. Electronic over-circuit protection per group of four channels. Fault indication: short circuit or overload of an output.	24 VDC 16 A max.	100 mAmax. draw	118 x 116 x 117 (mm)	480.00
Four isolated groups. Electronic over-circuit protection per point. Fault indication: short circuit or overload of an output, over temperature of an output driver.	24 VDC 8A max.	100 mAmax. draw	118 x 116 x 117 (mm)	660.00
One isolated group. Electronic over-circuit protection per point. Fault indication: short circuit of an output.	24 VDC 1.6 A max.	50 mAmax. draw	81 x 116 x 117 (mm)	270.00
One isolated group. Electronic over-circuit protection per group of four channels.	24 VDC 3.2 A max.	100 mAmax. draw	118 x 116 x 117 (mm)	290.00
One isolated group. Electronic over-circuit protection per group of four channels.	24 VDC 8A max.	100 mAmax. draw	118 x 116 x 117 (mm)	395.00
Four isolated groups. Electronics over-circuit protection per point. Fault indication: short circuit of an output.	24 VDC 8A max.	100 mAmax. draw	118 x 116 x 117 (mm)	360.00
Four isolated groups.	24 VDC	100 mAmax. draw	118 x 116 x 117 (mm)	610.00
Two isolated groups. Electronic over-circuit protection per point. Fault indication: short circuit of an output.	24 VDC 8A max.	100 mAmax. draw	81 x 116 x 117 (mm)	340.00
Two isolated groups.	120 oe 230 VAC 8A max.	100 mAmax. draw	118 x 116 x 117 (mm)	400.00

Process data uptime: 2.5 ms per channel. Fault indication: failure of +24 V I/O supply voltage, failure of a ±15 V or +5 V I/O voltage, blown fuse at I/O supply voltage.	24 VDC 80 mAmax.	120 mAmax. draw	118 x 116 x 117 (mm)	875.00
Process data update time: 1 ms per channel. Fault indication: failure of +24 V I/O supply voltage, failure of ±15 V or +5 V I/O voltage, blown fuse at I/O supply voltage.	24 VDC 0.15 A max.	130 mAmax. draw	118 x 116 x 117 (mm)	825.00
Process data update time: 3 ms per channel. Fault indication: failure of +24 I/O supply voltage, failure of ±15 V or +5 V I/O voltage, blown fuse at I/O supply voltage.	24 VDC 80 mAmax.	120 mAmax. draw	118 x 116 x 117 (mm)	975.00
Process data update time: 1 ms per channel. Fault indication: failure of +24 I/O supply voltage, failure of ±15 V or +5 V I/O voltage, blown fuse at I/O supply voltage.	24 VDC 0.25 A max.	130 mAmax. draw	118 x 116 x 117 (mm)	825.00
Process data update time: 1 ms per channel. Fault indication: failure of +24 V I/O supply voltage, failure of ±15 V or +5 V I/O voltage, blown fuse at I/O supply voltage.	24 VDC 0.25 A max.	130 mAmax. draw	118 x 116 x 117 (mm)	825.00

PCPsupported. 3964 R-mode supported. 4 k byte buffer in send/receive direction.	24 VDC 400 mAtypical	130 mAmax. draw	44 x 116 x 117 (mm)	549.00
PCP supported. Refer to module data sheet no. 0615 for further details. Fault indication: failure of +24 V I/O supply voltage, blown fuse at I/O supply voltage.	24 VDC 4A max.	220 mAmax. draw	118 x 116 x 117 (mm)	700.00
PCP supported. Refer to module data sheet no. 0614 for further details.	24 VDC	280 mAmax. draw	118 x 116 x 117 (mm)	1290.00

INTERBUS Inline Components

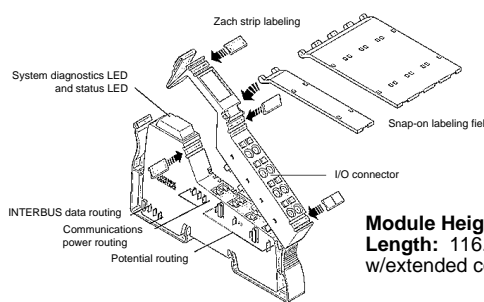
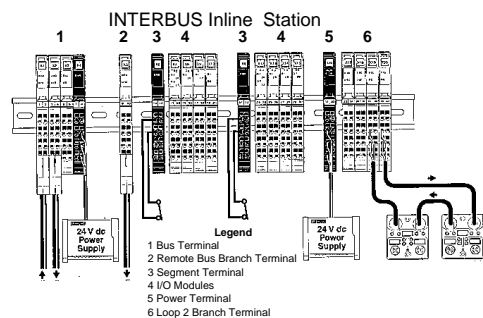

Connection Data: spring clamps
AWG: 24-16

Module Height: 71.5 mm
Length: 116.1 mm (141.1mm w/extended connector)

The information on this page is an overview of the components in an Inline Automation Station. Detailed information is contained in data sheets for the listed terminals or in the user manual INTERBUS Inline System Manual (order no. 2743048). Data sheets may be obtained through Phoenix Contact's FAX-ON-DEMAND System (800-944-9901) or by calling Carlton-Bates Company.

The INTERBUS Inline product family is a modular automation system that is integrated into an INTERBUS system. Inline modules are joined together to create functional units which meet the requirements of the application. The control cabinet layout is designed by grouping the various I/O modules according to function. Both communication and power routing is accomplished automatically with the physical interconnection between the I/O modules. Additional networking options permit the network to branch to either a remote bus segment or Loop 2 segment.

Bus Terminals can accommodate up to 63 modules. A copper cable is used to couple it to INTERBUS, DeviceNet or Profibus networks. A **Remote Bus Branch Terminal** is used for creating a remote bus branch and can only be inserted directly after the bus terminal. A **Loop 2 Branch Terminal** is used to extend the Inline station via a Loop 2 segment. It is recommended that a Loop 2 branch terminal module be electrically isolated from the other Inline station components via a power terminal (IRIL24PWRIN). I/O voltage is supplied to the I/O module via the integrated power bus built into each of the I/O modules. **Segment Terminals** provide the ability to segment this I/O power for an individual module or group of I/O modules. Note that the maximum current allowed through the integrated power bus is 8 amps. The **Power Terminals** provide power to the I/O circuit and allows electrical isolation. Power Terminals are also used when the current of the integrated power bus could exceed 8 amps. **Approvals:** UL Recognized (U.S. and Canada).

Terminal Modules (connectors must be ordered separately)

Mfr.'s Type	Order No.	Description	Use Connector Type	Width (mm)	Each
IBSIL 24BK-T	2726188	INTERBUS Bus terminal, 24 VDC	1	48.8	230.00
IBIL 24BK-RB-T	2727941	Remote bus branch terminal, 24 VDC	2	12.2	150.00
IBIL 24L2	2724886	Loop 2 branch terminal, 24 VDC	4 (4-required)	48.8	210.10
IBIL 24SEG	2726324	Segment terminal, 24 VDC, without fuse	5 or 6	12.2	16.00
IBIL 24SEG/F	2727747	Segment terminal, 24 VDC, with 6.3 A fuse	5 or 6	12.2	24.00
IBIL 24PWRIN	2726311	Power terminal, 24 VDC	5 or 6	12.2	18.75
IBIL 24DI2	2726201	Digital input terminal, 2-inputs, 24 VDC, 4-wire connection (PNP sensor)	3 or 4	12.2	32.00
IBIL 24DI4	2726214	Digital input terminal, 4-inputs, 24 VDC, 3-wire connection (PNP sensor)	7 or 8	12.2	48.50
IBIL 24DI8	2726227	Digital input terminal, 8-inputs, 24 VDC, 4-wire connection (PNP sensor)	3 or 4 (4-required)	48.8	90.00
IBIL 24DI16	2726230	Digital input terminal, 16-inputs, 24 VDC, 4-wire connection (PNP sensor)	7 or 8 (4-required)	48.8	180.00
IBIL 24DO2-2A	2726243	Digital output terminal, 2-outputs, 24 VDC, 2 A, 4-wire connection	3 or 4	12.2	68.00
IBIL 24DO4	2726256	Digital output terminal, 4-outputs, 24 VDC, 500 mA, 3-wire connection	8 or 9	12.2	64.00
IBIL 24DO8	2726269	Digital output terminal, 8-outputs, 24 VDC, 500 mA, 4-wire connection	3 or 4 (4-required)	48.8	118.00
IBIL 24DO16	2726272	Digital output terminal, 16-outputs, 24 VDC, 500 mA, 3-wire connection	8 or 9 (4-required)	48.8	218.00
IBILAI2/SF	2726285	Analog input terminal, 2-inputs, 0 to 20 mA, 4 to 20 mA, -20 to +20 mA, 0 to 10 V, -10 to +10 V, 2-wire connection	2 or 4	12.2	262.00
IBILAO1/U/SF	2727776	Analog output terminal, 1 output, 0 to 10 V, 2-wire connection	2 or 4	12.2	145.00
IBILAO1/SF	2726298	Analog output terminal, 1 output, 0 to 20 mA, 4 to 20 mA, 0 to 10 V, 2-wire connection	2 or 4	24.4	168.00
IBILTEMP2UTH	2727763	Thermocouple terminal, 2 inputs, 2-wire connection	2 or 4	12.2	295.00
IBILTEMP2RTD	2726308	RTD terminal, 2 inputs, 2-, 3- or 4-wire connections	2 or 4	12.2	295.00

Connectors and Accessories

Mfr.'s Type	Order No.	Connector Type	Description	Each
IBILBK-PLSET	2727792	1	Connector set (4-connectors: 2-shielded, 1-standard, 1-power, black)	25.00
IBILSCN-6SHIELD	2726353	2	I/O shielded connector	8.50
IBILSCN-8-CP	2727608	3	I/O standard connector, color coded*	4.50
IBILSCN-8	2726337	4	I/O standard connector, without color code	4.00
IBILSCN-PWRIN-CP	2727637	5	Power connector, black, color coded*	4.50
IBILSCN-PWRIN	2727462	6	Power connector, black, without color code	4.00
IBILSCN-12-ICP	2727611	7	I/O extended double signal connector, color coded**	7.50
IBILSCN-12	2726340	8	I/O extended double signal connector, without color code	7.00
IBILSCN-12-OC	2727624	9	I/O extended double signal connector, color coded †	7.50
IBILFIELD 2	2727501		Labeling field for terminals with 12.2 mm or 24.4 mm widths	6.00
IBILFIELD 8	2727515		Labeling field for terminals with 48.8 mm widths	10.00
ZBFM6-...	...		100 pc. marker sheet, several versions available (to order, see "Accessories for Terminal Blocks")	...

*Color codes for standard and power connectors (1st row: w/o color print, 2nd row: red, 3rd row: blue, 4th row: green/yellow). **Color codes for extended -ICP connectors (1st row: w/o color print (signals), 2nd row: red, 3rd row: blue, 4th row: w/o color print (signals), 5th row: red, 6th row: blue). † Color codes for extended -OC connectors (1st row: w/o color print (signals), 2nd row: blue, 3rd row: green/yellow, 4th row: w/o color print (signals), 5th row: blue, 6th row: green/yellow).

The information on this page is an overview of the components that make up the Loop 2 product family. Detailed information is contained in data sheets or in the INTERBUS Loop 2 System Manual (order no. 2743491). Data sheets may be obtained from either Phoenix Contact's Website INLINEIO.com, FAX-ON-DEMAND System (800-944-9901) or by calling Carlton-Bates.

INTERBUS Loop 2 products combine user data signals with power for bus devices and transmit both signals through an unshielded 2-wire cable. Additionally, INTERBUS Loop 2 modules with IP67 protection, can be directly integrated into an Inline station by means of a branch terminal. Circuits are displayed with built-in diagnostic LED's and all modules use the solderless QUICKON connectors, eliminating the need for tools and striping of the conductors.

The machine mountable **Bus Terminal** can support up to 63 devices. In the event the minimum voltage for a device (19.2V) is not achievable or the maximum current load (1.8 A) is exceeded, the **Power In Module** should be used to re-establish these power requirements. The **Inline Loop 2 Branch Terminal** permits a seamless integration of the Loop 2 product offering into an Inline station. **Approvals:** ULRecognized (U.S. and Canada).

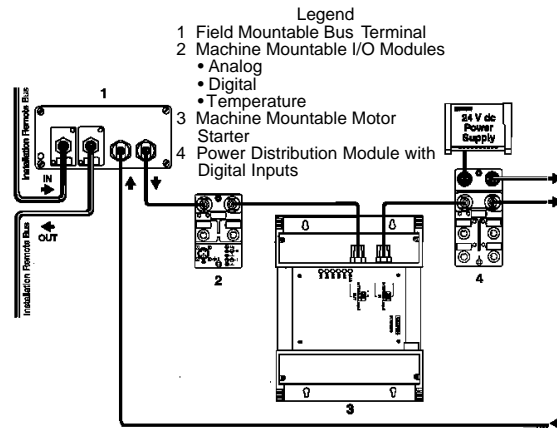

- Legend
- 1 Field Mountable Bus Terminal
 - 2 Machine Mountable I/O Modules
 - Analog
 - Digital
 - Temperature
 - 3 Machine Mountable Motor Starter
 - 4 Power Distribution Module with Digital Inputs

System Parameters

Cable length between 2 devices.20 m (65.6 ft) max.
 Cable length in a loop.200 m (656.2 ft) max.
 Current load in a loop.1.8 A max.
 Voltage on a device.19.2 V min.
 Number of devices in a loop.63 max.

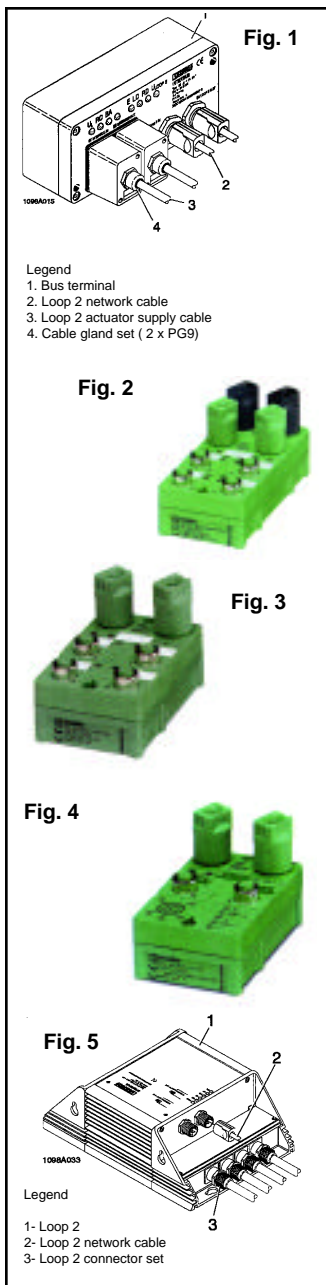

Loop 2 Components

Mfr.'s Type	Order No.	Fig.	Description	Each
IBSL2IP24BK-T	2732376	1	Bus terminal with Loop 2 branch (data sheet 5880)	585.00
IBL2BOX24PWRINDI4/4-M12	2732392	2	Power in module w/4 digital inputs, 24 VDC, 4-wire, connection for additional power supply (data sheet 5881)	198.00
IBIL24L2	2727886	*	Inline Loop 2 branch terminal, 24 VDC (data sheet 5662)	210.00
IBL2BOX24DI4/4M12	2731982	3	Digital input module, 4- inputs, 24 VDC, 4-wire (data sheet 5870)	138.00
IBL2BOX24DI4/4M12-D	2732761	3	Same as above with internally cross-wired inputs (data sheet 5989)	138.00
IBL2BOX24DI8/4M12	2731995	3	Digital input module, 8- inputs, 24 VDC, 4- wire (data sheet 5873)	198.00
IBL2BOX24DO4/4M12-2A	2732347	2	Digital output module, 4- outputs, 24 VDC, 2 A, 3-wire (data sheet 5871)	182.00
IBL2BOX24DO4/4M12-2A-D	2732774	2	Same as above with internally cross-wired outputs (data sheet 5988)	182.00
IBL2BOX24DIO2/2/4M12-2A	2732004	2	Digital I/O module, 2-inputs, 24 VDC, 4- wire; 2- outputs, 24 VDC, 2 A, 3-wire (data sheet 5872)	174.00
IBL2BOX24DIO2/2/4M12-2A-D	2732787	2	Same as above with internally, cross-wired inputs and outputs (data sheet 5990)	174.00
IBL2BOXAI2/2M12	2731908	4	Analog input module, 2- inputs, 0-10 VDC, 2-10 VDC, 0-20 mA, 4-20 mA, 2- wire (data sheet 5874)	360.00
IBL2BOXAO1/2/UM12	2731940	4	Analog output module, 1- output, -10 VDC to +10 VDC, 2- wire (data sheet 5877)	290.00
IBL2BOXAO1/2/IM12	2731937	4	Analog output module, 1- output, 0-20 mA, 4-20 mA, 2- wire (call for data sheet)	290.00
IBL2BOXTEMP2/2M12	2731924	4	Analog input thermocouple/RTD module, 2-inputs, RTD, TC, 2, 3 and 4- conductor sensors, 2- wire (data sheet 5875)	360.00
IBL2IP500MLR4-6A	2732389	5	Motor starter, machine mounted, 4- channels, 500 VAC, 6 A (call for data sheet)	1512.00

*not shown. For information on this product see "INTERBUS Inline System".

Accessories

Mfr.'s Type	Order No.	Description	Each
IBSLSLCCU2/1.5-METER	2721620	Loop 2 network cable, green, 2-cond., AWG 16 (priced per meter)	1.60/mtr.
IBSLPSCCU3/1.5-METER	2722137	Loop 2 actuator supply cable, black, 3- cond., AWG 16 (priced per meter)	2.30/mtr.
IBSINBCMETER	2723136	INTERBUS network with power cable (priced per meter)	7.80/mtr.
SABCG/PG9	1662133	Cable gland set (PG9), threaded, for INTERBUS connections on Loop 2 bus terminal (2 pcs./pkg.)	5.95/mtr.
IBSIPPROTI/O	2759919	Protective caps for unused M12 sockets	1.63
IBSLMLRPLSET4-6A	2724533	Loop 2 connector set (includes PG glands) for motor starter	95.00