



## **Mondial<sup>®</sup> Transporters ST64, ST70**

August 2013 GLO  
Pub. No. 234-3449-05



*Read this Manual  
and Retain for  
Future Reference*

## Ferno Technical Support

Customer service and product support are important aspects of each Ferno product. Please have the product serial number available when calling, and include it in all written communications. For technical support questions:

Telephone (Toll-free)	1.800.733.3766 ext. 1010
Telephone	1.937.382.1451 ext. 1010
Email	quality.products@ferno.com

## Ferno Customer Relations

For ordering assistance or general information:

### CANADA AND THE U.S.A.

Telephone (Toll-free)	1.877.733.0911
Telephone	1.937.382.1451
Fax (Toll-free)	1.888.388.1349
Fax	1.937.382.1191
Internet	www.ferno.com

### ALL OTHER LOCATIONS

For assistance or information, please contact your Ferno distributor. If you do not have a Ferno distributor, please contact Ferno Customer Relations:

Ferno-Washington, Inc., 70 Weil Way  
Wilmington, Ohio 45177-9371, U.S.A.

Telephone	+1.937.382.1451
Fax	+1.937.382.6569
Internet	www.ferno.com

## Disclaimer

This manual contains general instructions for the use, operation and care of this product. The instructions are not all-inclusive. Safe and proper use of this product is solely at the discretion of the user. Safety information is included as a service to the user. All other safety measures taken by the user should be within and under consideration of applicable regulations. It is recommended that training on the proper use of this product be provided before using this product in an actual situation.

Retain this manual for future reference. Include it with the product in the event of transfer to new users. Additional free copies are available upon request from Customer Relations.

## Proprietary Notice

The information disclosed in this manual is the property of Ferno-Washington, Inc., Wilmington, Ohio, USA. Ferno-Washington, Inc. reserves all patent rights, proprietary design rights, manufacturing rights, reproduction use rights, and sales use rights thereto, and to any article disclosed therein except to the extent those rights are expressly granted to others or where not applicable to vendor proprietary parts.

## Limited Warranty Statement

The products sold by Ferno are covered by a limited warranty, which is printed on all Ferno invoices. The complete terms and conditions of the limited warranty, and the limitations of liability and disclaimers, are also available upon request by calling Ferno at 1.800.733.3766 or 1.937.382.1451.



### USERS' MANUAL

To request additional free users' manuals, contact Ferno Customer Relations, your Ferno distributor, or visit [www.ferno.com](http://www.ferno.com).

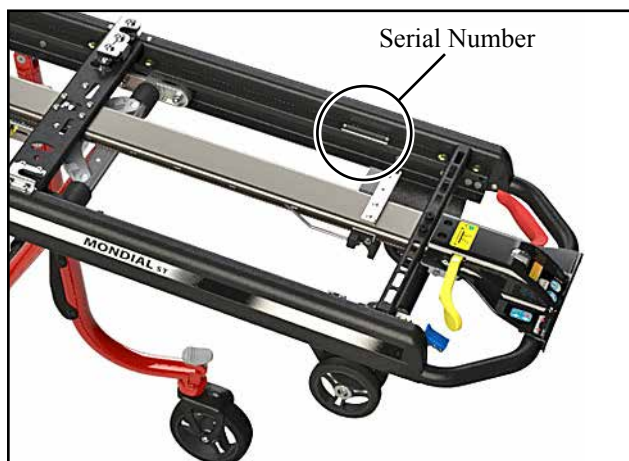

Serial Number \_\_\_\_\_

Location: Side Rail on Patient Left side



Ferno-Washington, Inc.  
70 Weil Way  
Wilmington, Ohio 45177-9371 U.S.A.



Ferno (UK) Limited  
Stubs Beck Lane, Cleckheaton  
West Yorkshire BD19 4TZ, United Kingdom

## TABLE OF CONTENTS

Section	Page	Section	Page
Ferno Technical Support _____	2	4.9 EZ Load™ Automatic Leg Release (Loading-End Legs) _____	13
Ferno Customer Relations _____	2	4.10 EZ Load™ Automatic Leg Release (Control-End Legs, Optional) _____	13
<b>1 - Safety Information</b> _____	<b>4</b>	4.11 Safety-Lock Device (Optional) _____	14
1.1 Warning _____	4	4.12 Leg Lock (Blue Lever, Optional) _____	14
1.2 Important _____	4	<b>5 - Using the Transporter</b> _____	<b>15</b>
1.3 Tip _____	4	5.1 Before Placing the Transporter in Service _____	15
1.4 Bloodborne Disease Notice _____	4	5.2 General Guidelines for Use _____	15
1.5 Safety and Instruction Labels _____	5	5.3 Attaching and Removing A Stretcher _____	16
1.5 Transporter and Fastening System Compatibility _____	4	5.4 Changing Transporter Positions _____	17
1.6 Symbol Glossary _____	5	5.5 Transferring the Patient _____	18
<b>2 - Operator Skills and Training</b> _____	<b>6</b>	5.6 Rolling the Transporter _____	19
2.1 Skills _____	6	5.7 Loading the Transporter _____	20
2.2 Training _____	6	5.8 Unloading the Transporter _____	21
2.3 Height and Strength Considerations _____	6	5.9 Carrying the Transporter _____	22
<b>3 - About the Transporter</b> _____	<b>7</b>	5.10 One Operator, Empty Transporter _____	22
3.1 Description _____	7	5.11 Using Additional Help _____	23
3.2 Compliance _____	7	<b>6 - Maintenance</b> _____	<b>24</b>
3.3 Components _____	8	6.1 Maintenance Schedule _____	24
3.4 General Specifications _____	9	6.2 Tracker™ (Optional) _____	24
3.5 Bed Positions _____	9	6.3 Disinfecting the Transporter _____	25
<b>4 - Using the Features</b> _____	<b>10</b>	6.4 Cleaning the Transporter _____	25
4.1 EZ Pull™ Leg Control Handles _____	10	6.5 Waxing the Transporter _____	25
4.2 Leg-Status Indicator _____	10	6.6 Inspecting the Transporter _____	25
4.3 Stretcher Release Lever (Yellow) _____	10	6.7 Lubricating the Transporter _____	26
4.4 Swivel-Lock Release Lever _____	11	<b>7 - Parts, Service, and Accessories</b> _____	<b>27</b>
4.5 Stretcher Slam Latches _____	12	7.1 Parts and Service _____	27
4.6 Wheel Locks _____	12	7.2 Accessories _____	27
4.7 Transport Wheels _____	12	<b>Training Record</b> _____	<b>28</b>
4.8 Intermediate Loading Wheels _____	13	<b>Maintenance Record</b> _____	<b>28</b>

# 1 - SAFETY INFORMATION

## 1.1 Warning

Warning notices indicate a potentially hazardous situation which, if not avoided, could result in injury or death.

 <b>WARNING</b>
<b>Untrained operators can cause injury or be injured. Permit only trained personnel to operate the transporter.</b>
<b>Improper use of the transporter can cause injury. Use the transporter only for the purpose described in this manual.</b>
<b>Releasing the swivel locks increases the possibility for the transporter to tip. Maintain control of the transporter at all times.</b>
<b>Improper operation can cause injury. Operate the transporter only as described in this manual.</b>
<b>An unattended patient can be injured. Stay with the patient at all times.</b>
<b>An unrestrained patient can fall off the transporter and be injured. Use restraints to secure the patient on the transporter.</b>
<b>An improperly secured stretcher can separate from the transporter and cause injury. Attach the stretcher securely and verify that the slam latches have locked.</b>
<b>Rolling the transporter sideways can cause the transporter to tip and injure the patient or operators. Roll the transporter only with the head-end or foot-end first.</b>
<b>An unlocked undercarriage can cause injury. Before removing the transporter from the ambulance, confirm that both sets of legs unfold completely and lock.</b>
<b>Helpers can cause injury or be injured. Maintain control of the transporter, operate the controls, and direct all helpers.</b>
<b>Improper maintenance can cause injury. Maintain the transporter only as described in this manual.</b>
<b>Improper parts and service can cause injury. Use only Ferno parts and Ferno-approved service on the transporter.</b>
<b>Modifying the transporter can cause injury and damage. Use the transporter only as designed by Ferno.</b>
<b>Attaching improper items to the transporter can cause injury. Use only Ferno-approved items on the transporter.</b>

## 1.2 Important

Important notices emphasize important usage or maintenance information. Failure to follow Important notices could result in damage to the product or property damage.

<b>Important</b>
------------------

## 1.3 Tip

Tips provide recommendations for easier use of the product.



## 1.4 Bloodborne Disease Notice

To reduce the risk of exposure to bloodborne diseases such as HIV-1 and hepatitis when using the transporter, follow the disinfecting and cleaning instructions in this manual.

## 1.5 Transporter and Fastening System Compatibility

For the purpose of the following notice, the Mondial® ST64 and ST70 and all other Ferno transporters are included under the generic term “cot”.

Combining different manufacturer’s products such as a Ferno cot with a non-Ferno fastening system can increase the user’s risk of injury and damage.

Ferno-Washington, Inc. cots are designed for use only with Ferno-manufactured fastening systems. Use of this Ferno cot with a non-Ferno fastening system is misuse of the Ferno product.

The user assumes responsibility for the outcome of known, intentional misuse.

### 1.5 Safety and Instruction Labels

Safety and instruction labels place important information from the users' manual on the transporter. Read and follow label instructions. Replace worn or damaged labels immediately. New labels are available from your Ferno distributor.



Safety Information Label  
(Control panels)



Swivel Lock Release Lever  
(Loading-end control panel)

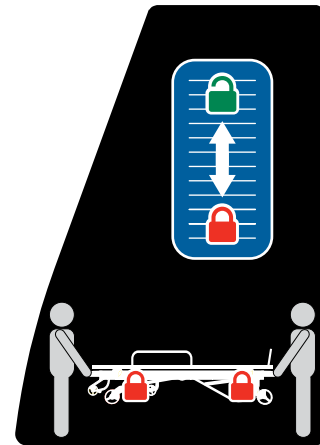

Low-Bed Leg Lock Lever  
(Control-end control panel, when equipped)

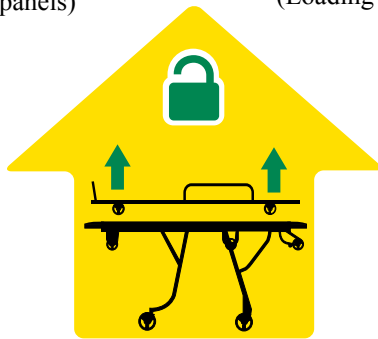

Stretcher Release Lever  
(Control-end spine)

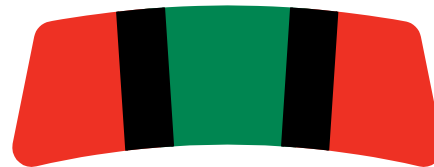

Undercarriage Lock Status  
(Undercarriage lock mechanisms)

### 1.6 Symbol Glossary

The symbols defined below are used on the transporter and in this users' manual. Ferno uses symbols recognized by the International Standards Organization (ISO), American National Standards Institute (ANSI) and the emergency medical services industry.



General Warning of  
Potential Injury



QR Code (Scan with  
Smartphone to access  
online material)



Read the Users'  
Manual



Operation Requires Two  
Trained Operators



Load Limit



Do Not  
Lubricate



Lubricate



Locked



Unlocked



Manufacturer

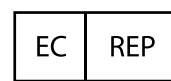

Authorized  
Representative in the  
European Community



Transporter  
meets European  
Union Standards

## 2 - OPERATOR SKILLS AND TRAINING

### 2.1 Skills

Operators using the transporter need:

- a working knowledge of emergency patient-handling procedures.
- the ability to assist the patient.

### 2.2 Training

Operator trainees need to:

- read and understand this manual and the manuals for the fastener and stretcher(s) used with the transporter.
- be trained on the use of the transporter, the fastener, and the stretcher(s) used with the transporter.
- practice with the transporter before using it with a patient.
- record their training information. A sample training record sheet is provided on page 28.

#### **WARNING**

**Untrained operators can cause injury or be injured. Permit only trained personnel to operate the transporter.**

### 2.3 Height and Strength Considerations

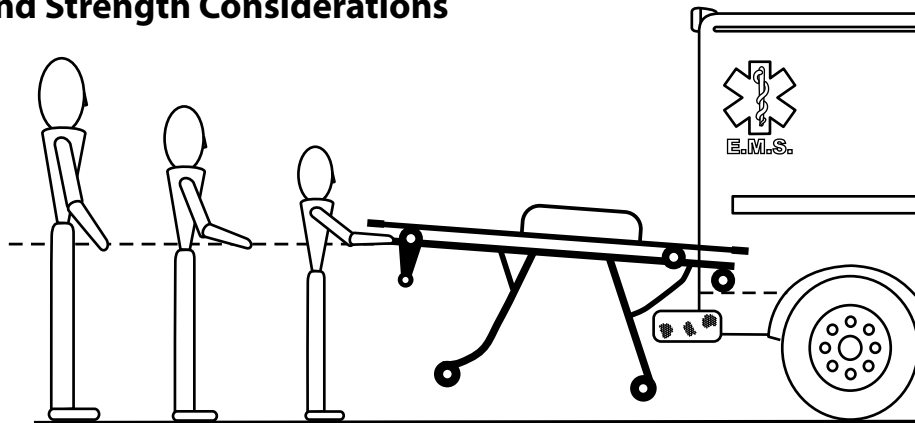

When unloading the transporter, the foot-end operator must lift and hold the weight of the transporter, patient and equipment high enough for the wheels to remain off the ground until the undercarriage legs completely unfold and lock into place.

Supporting this weight requires greater strength from short operators than from tall operators because short operators must raise their arms higher in relation to their shoulders.

Be aware that if the ambulance is parked on an uneven surface, the foot-end operator (and any helpers) may need to lift the transporter higher than normal to allow the legs to unfold completely and lock.

**Note:** Use additional help as needed to lift the weight of the transporter, patient and equipment (see Using Additional Help, page 23).

## 3 - ABOUT THE TRANSPORTER

### 3.1 Description

The Models ST64 and ST70 Mondial® Series Transporters are emergency patient-handling devices designed to transport a patient in a ground-based ambulance. In this manual, the term “transporter” is used when features are identical for both models. The specific transporter name is used when features differ.

The transporter is for professional use by a minimum of two trained operators. It is designed for roll-in loading to help reduce the risk of back injury to medical service personnel.

The transporter is part of a three-component patient-handling system when matched with a compatible Ferno® stretcher and fastener (not included).

#### COMPATIBLE STRETCHERS AND STRETCHER CHAIRS

- Mondial® RS2, RS3, RS4 stretchers
- EFX1 stretcher chair
- EFX2, EFX3, EFX4 stretchers

#### COMPATIBLE FERNO® FASTENERS

- Ferno® FL1
- Ferno® EFX-Lock (conversion required, kit available separately)

#### TRANSPORTER FEATURES

- Ergonomic control handles
- Choice of red, green, or silver legs
- Six bed positions and a folded position
- ST64: loading height of 64 cm
- ST70: loading height of 70 cm
- Stretcher slam-locks (two)
- EZ Pull™ control handles allow operators to operate the control handle first, before assuming the weight of the transporter during position changes.
- Control handles not required for raising the transporter
- Automatic loading-leg release (when loading transporter into an ambulance); control handles not required to unlock loading legs
- Intermediate loading wheels reduce the amount of lifting required when loading the transporter into, and unloading it from, an ambulance.
- Reversible stretcher mounting
- Four 150 mm transport wheels
  - Control-end wheels with wheel locks (two)
  - Loading-end wheels with swivel-locks (two)
- Extremely high-visibility reflective safety stripes
- Loading/Operator-end leg protectors
- (Optional) No control handles required for loading the transporter if equipped with EZ Load™ automatic leg release.
- (Optional) Leg lock locks both transporter legs in Bed Position 1 or Bed Position 3.
- (Optional) Safety Lock Device
- (Optional) Soft-ride transport wheels with antistatic feature

### WARNING

**Improper use of the transporter can cause injury. Use the transporter only for the purpose described in this manual.**

### 3.2 Compliance

#### MEDICAL DEVICE DIRECTIVE

Ferno products meet the requirements of Medical Device Directive 93/42/EEC as established by the European Union.



#### CERTIFICATION

The Mondial® ST64 or ST70 transporter, when used with a Ferno® Mondial® or EFX stretcher plus a Ferno® FL1 or EFX-Lock fastener, meets European Harmonized Standards.

Mondial® series products were independently tested by TÜV Rheinland, Germany, and certified compliant with EN 1865:1999, governing patient transport equipment, and EN 1789:2007, governing road ambulances.



#### U.S.A. NOTICE

The transporter is for use with ambulances that meet the requirements of the “Star of Life” certification via Federal Ambulance Specification KKK-A-1822. For information, contact:

Federal Supply Services, Specifications Section  
Suite 8100  
470 E. L’Enfant Plaza, SW  
Washington, DC 20407



### 3.3 Components

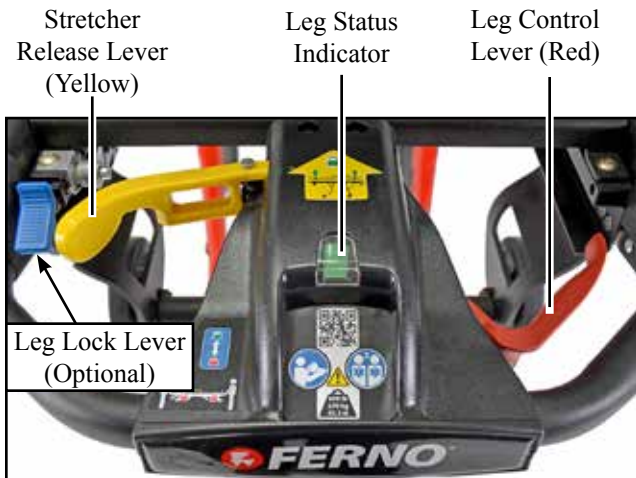

**Control-End Panel**

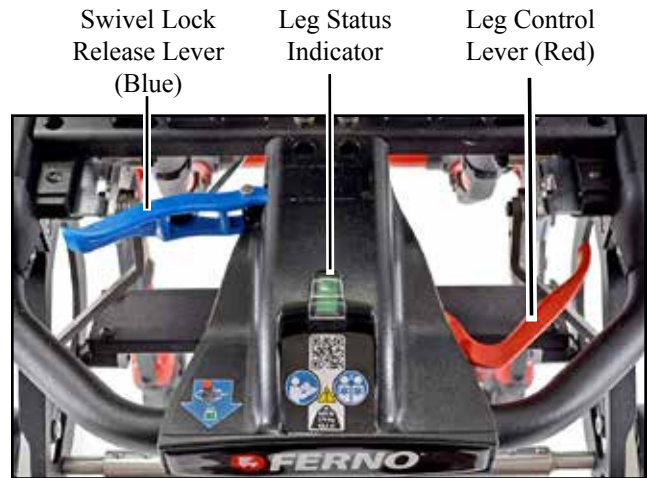

**Loading-End Panel**

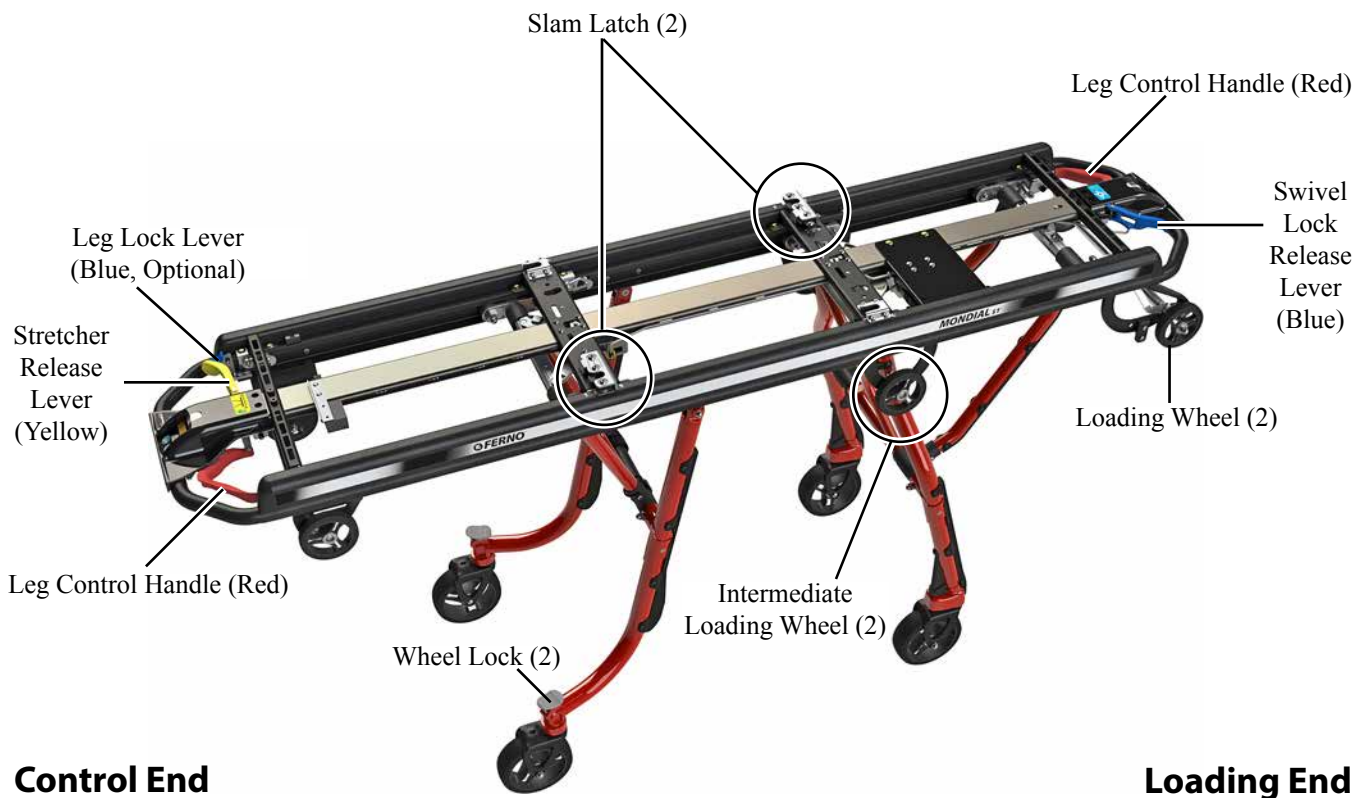

**Control End**

**Loading End**



**Load Limit**

600 lb  
270 kg  
42.5 st

Inspect the transporter if the load limit has been exceeded (See *Inspecting the Transporter*, page 25).



### 3.4 General Specifications

Most general specifications are rounded to the nearest whole number. For more information, contact Ferno Customer Relations (page 2) or your Ferno distributor.

Ferno reserves the right to change specifications without notice.

#### MODEL ST70 AND MODEL ST64

Construction	Aluminum
Transport Wheels	
Diameter	150 mm/6 in.
Width	44 mm/2 in.
Wheel Bearings	Sealed/greaseless
Bed Surface	Aluminum panels
Length	1970 mm/77.5 in.
Width	550 mm/22 in.
Load Limit	270 kg/600 lb
Load Limit (UK)	42.3 stone

#### MODEL ST70

<b>Height<sup>1</sup></b>	
Rolling Position 6	1045 mm/41 in.
Bed Position 5	984 mm/39 in.
Bed Position 4	905 mm/36 in.
Bed Position 3	787 mm/31 in.
Bed Position 2	600 mm/24 in.
Bed Position 1	352 mm/14 in.
Folded Position	343 mm/14 in.
Weight (ST70) <sup>2</sup>	28 kg/62 lb

#### MODEL ST64

<b>Height<sup>1</sup></b>	
Rolling Position 6	987 mm/39 in.
Bed Position 5	930 mm/37 in.
Bed Position 4	857 mm/34 in.
Bed Position 3	746 mm/29 in.
Bed Position 2	560 mm/22 in.
Bed Position 1	356 mm/14 in.
Folded (Ambulance) Position	346 mm/14 in.
Weight (ST64) <sup>2</sup>	28 kg/62 lb

#### AMBULANCE SPECIFICATION

ST64 Floor/Tray Range <sup>3</sup>	670-730 mm/27-29 in.
ST70 Floor/Tray Range <sup>3</sup>	730-790 mm/29-31 in.

<sup>1</sup> Height measurements are the distance from the ground to the top of the stretcher seat panel with a stretcher on the transporter.

<sup>2</sup> Weight is without stretcher or optional features.

<sup>3</sup> Ambulance floor/tray range is the recommended height range for proper loading and unloading.

### 3.5 Bed Positions

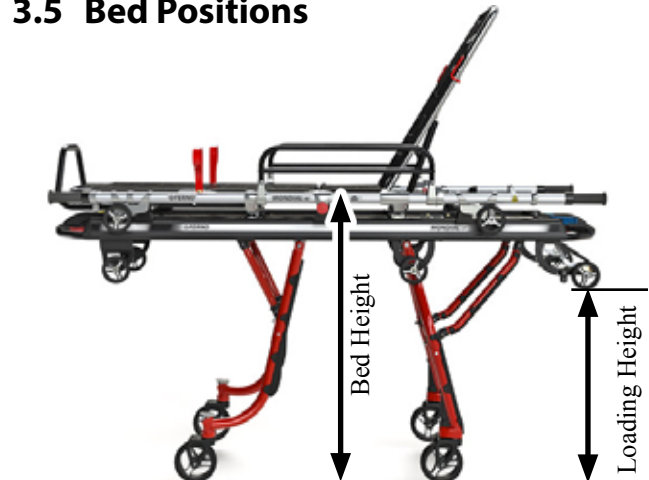

**Position 6 (Highest Rolling Position)**

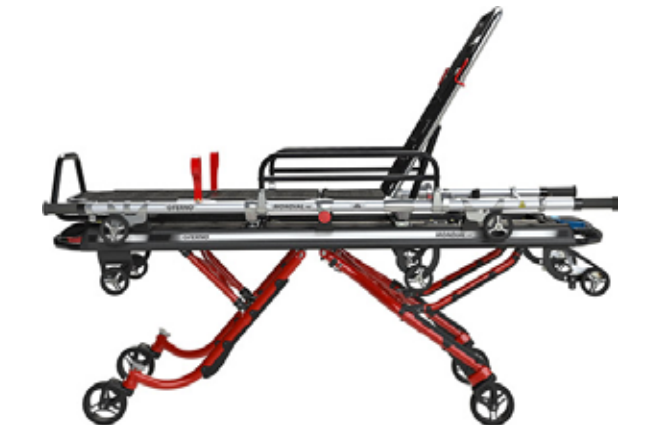

**Position 3 (Mid-Level Transfer/Rolling Position)**



**Position 1 (Lowest Transfer Position)**

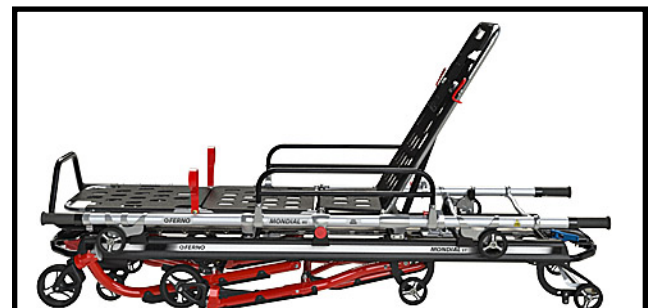

**Folded Position**

## 4 - USING THE FEATURES

### 4.1 EZ Pull™ Leg Control Handles

- **Purpose:** Unlocks the legs nearest the handle, allowing the transporter to be lowered
- **Location:** Each end of the transporter, accessible to the operator's right hand (Figure 1)
- **Use:** The EZ Pull™-style handle allows the operators to operate the handle first, before lifting the transporter so they can and lift evenly. (For complete instructions, see *Using the Transporter*, pages 15-23)
  - **Lowering:** Operators pull both control handles at the same time, then lift the transporter to take the weight off the locking mechanism. The leg-status indicator changes to red when the undercarriage is unlocked and changes to green when the lock is engaged (See *Leg-Status Indicator*, below).
  - **Raising:** Do not use the leg control handles. The operators simultaneously lift the transporter main frame until the transporter locks at the desired height.
  - **Loading:** The Control-end Operator uses the control-end handle when loading the transporter into an ambulance, **unless** the transporter is equipped with the control-end EZ Load™ automatic leg-release option. See *EZ Load™ Automatic Leg Release (Control-end Legs, Optional)*, page 13.



Figure 1 - Leg Control Handle

**Tip**

#### Leg-Status Indicator

The leg-status indicator indicates the state of the undercarriage leg lock:

**GREEN = Locked/Safe**

**RED = Unlocked/Ready to Lower or Load**

### 4.2 Leg-Status Indicator

- **Purpose:** Indicates the status of the leg lock.
- **Location:** Control panel at each end of the transporter
- **Use (Figure 2):** The indicator changes automatically when the leg control handle at the same end of the transporter is used.
  - **Green:** the legs are locked.
  - **Red:** the legs are unlocked (the leg-control handle has been pulled) and the transporter may be lowered or loaded into an ambulance.
  - Always maintain your grasp on the transporter until you verify that both legs have locked at the new position.



Figure 2 - Leg-Status Indicator

### 4.3 Stretcher Release Lever (Yellow)

- **Purpose:** Unlocks the stretcher for removal
- **Location:** Transporter control end (Figure 3).
- **Use:**
  1. **Control Operator:** Push and hold the stretcher release lever to disengage the transporter slam locks.
  2. **Both Operators:** Roll the stretcher slightly toward the loading end of the transporter to move the stretcher strike pins away from the slam latch locks.
  3. **Control Operator:** Release the lever.
  4. **Both Operators:** Grasp the stretcher with both hands and lift the stretcher off the transporter.



Figure 3 - Stretcher Release Lever

### 4.4 Swivel-Lock Release Lever

- **Purpose:** Unlocks and allows the loading-end caster wheels to swivel 360°
  - **By default, the casters are locked.** The caster wheels can roll but cannot swivel. The casters must be locked before loading the transporter into an ambulance.
  - **When unlocked,** the caster wheels can roll and swivel 360°, allowing the transporter to be maneuvered easily when space is limited.
- **Location:** Transporter loading end (Figure 4)
- **Use:** To unlock the casters for swiveling, the Loading-end Operator pulls and holds the blue swivel-lock release lever (Figure 4). The operator must continue holding the lever as long as the swivel function is needed.

To lock the caster wheels, release the lever. Roll the transporter toward the loading end until the wheels rotate and lock. This allows the pin inside the trailing end of the caster to engage the lock (Figure 5).

#### GUIDELINES FOR USE

- The transporter is more stable when the casters are locked and is more maneuverable when the casters can swivel.
- The swivel-lock release lever functions only when the transporter is in the highest rolling position (Bed Position 6).
- Lock the casters **before** loading the transporter into an ambulance so the wheels will not swivel and interfere with loading or unloading.
- Lock the casters **before** lowering the transporter. At a lower position, shifting weight on the transporter can cause an unlocked loading-end caster to swivel suddenly.
- The swivel caster lock pins are not designed to be lubricated (See *Lubricating the Transporter*, page 26). Use warm water and a mild detergent to clean the lock pins when needed.

**⚠ WARNING**

**Releasing the swivel locks increases the possibility for the transporter to tip. Maintain control of the transporter at all times.**

Tip

**Swivel Locks**

The loading-end caster wheels lock only when the swivel lock release lever is released and the trailing end of each caster orients with the lock pin.



**Figure 4 - Swivel-Lock Release Lever**

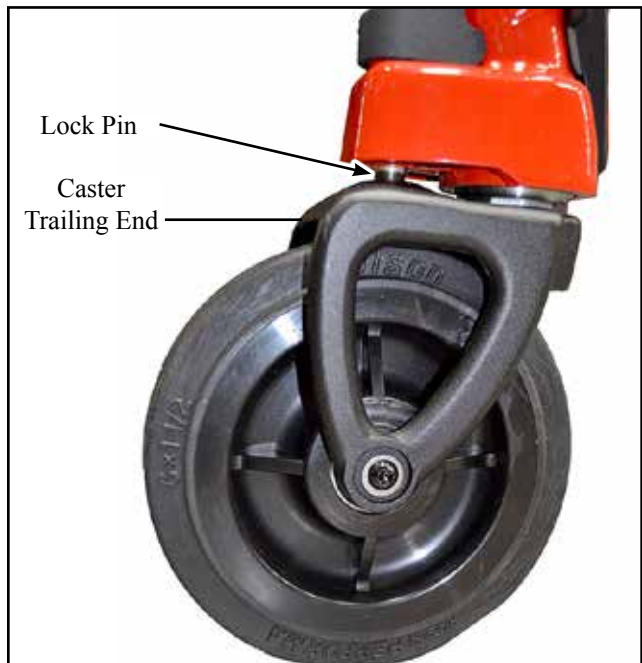
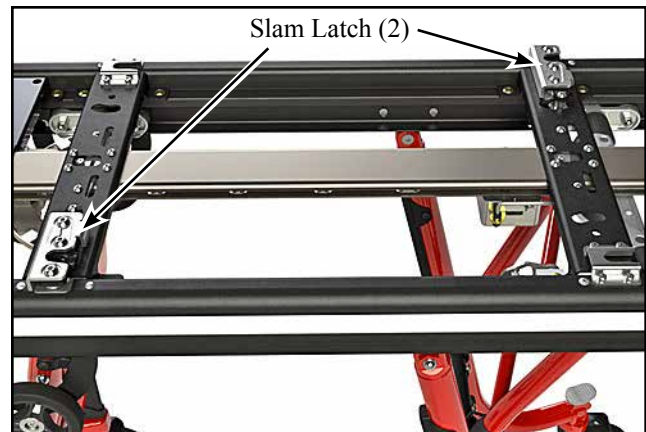

**Figure 5 - Swivel Caster**



## 4.5 Stretcher Slam Latches

- **Purpose:** The slam latches (Figure 6) capture and secure the stretcher on the transporter.
- **Location:** Transporter center
- **Use:** To engage the latches, roll the stretcher into the slam latches until the locks engage. To disengage, the Control Operator pushes the stretcher-lock release lever at the control end of the transporter (See *Stretcher Release Lever*, page 10).



**Figure 6 - Stretcher Slam Latches**

## 4.6 Wheel Locks

- **Purpose:** Aid for keeping the transporter from rolling during patient transfer and certain medical procedures
- **Location:** Control-end wheels
- **Use:** To engage, press the lock lever on top of the caster (Figure 7). To disengage, lift the lever up with your toe.

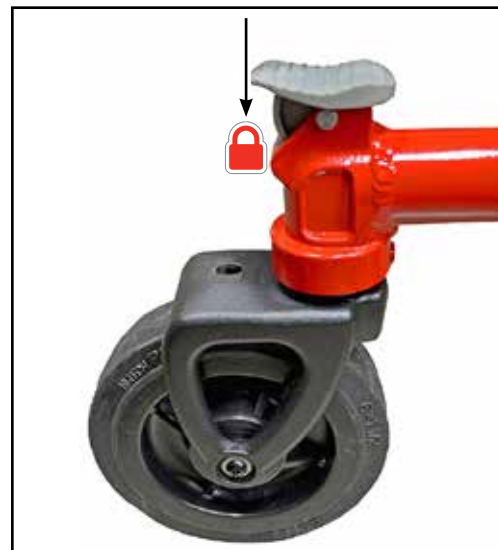

**Figure 7 - Wheel Lock**

## 4.7 Transport Wheels

Two versions of the 6-inch (152 mm) transport wheel are available: an open tri-spoke wheel, and a solid conductive wheel (Figure 8).

If the transporter is equipped with solid wheels, two of the four transport wheels (one at each end of the transporter) are conductive, allowing static electricity to dissipate and ground the cot. Each conductive wheel is marked with a small yellow spot on the side of the wheel. Transporter wheels with spokes do not have this feature.

The function of the wheel versions is identical, other than the conductivity feature. To order a set of conductive wheels, contact Ferno or your Ferno distributor. See *Parts and Service* on page 27.

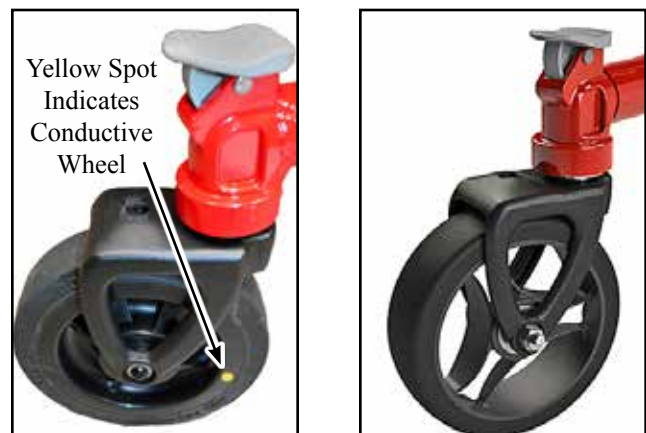

**Figure 8 - Conductive Wheel (Left) and Wheel with Spokes (Right)**

### 4.8 Intermediate Loading Wheels

- **Purpose:** Reduce the amount of lifting required when loading the transporter into an ambulance and when unloading the transporter from an ambulance
- **Location:** Transporter center
- **Use:** The intermediate loading wheels (Figure 9) are passive aids and do not require any action on the part of the operators.



Figure 9 - Intermediate Loading Wheel

### 4.9 EZ Load™ Automatic Leg Release (Loading-End Legs)

- **Purpose:** A mechanism connected to the loading wheels (Figure 10) automatically unlocks the loading-end legs for folding as the transporter is loaded into an ambulance.
- **Use:** The automatic leg release is a passive device that does not require any action on the part of the operators.



Figure 10 - Pressure On the Loading Wheels Unlocks the Loading-End Legs

#### Important

Do not hang a defibrillator or other object on the loading-end main frame. Objects hanging from the main frame could activate the leg-release mechanism.

### 4.10 EZ Load™ Automatic Leg Release (Control-End Legs, Optional)

- **Purpose:** When the transporter is equipped with this optional feature, the operators do not use any control handles when loading the transporter into an ambulance.
- **Use:** As the transporter is loaded into the ambulance and after the loading-end legs fold, the control-end legs are automatically unlocked for folding. See *Loading the Transporter* on page 20.

#### EZ Load™ Overview

When the operators load a transporter equipped with the EZ Load™ leg release into an ambulance, the following sequence occurs:

1. The operators begin loading the transporter into the ambulance.
2. The weight of the transporter on the loading wheels unlocks the loading-end legs for folding.
3. The operators continue pushing the transporter into the ambulance.
4. The folded loading-end legs automatically unlock the control-end legs for folding.
5. The operators finish pushing the transporter into the ambulance and secure it in a Ferno® fastener.

### 4.11 Safety-Lock Device (Optional)

- **Purpose:** The Safety-Lock Device prevents the transporter from being accidentally unloaded from the ambulance before the loading-end legs have locked. This optional device is required in some countries; check the requirements for your country.

The Safety-Lock Device consists of a hook positioned under the loading end of the transporter (Figure 11) and a user-installed catch plate installed on the ambulance floor or ramp.

- **Use:** As the operators unload the transporter from the ambulance:
  - **If the loading-end legs have not locked:** The transporter hook will catch on the user-installed catch plate. If this happens, raise the control end of the transporter until the loading-end legs swing down completely and lock. Use additional help as needed to lift the transporter. See *Using Additional Help*, page 23.
  - **If the loading-end legs have locked:** No action is needed. The hook on the transporter will not catch on the catch plate and the transporter may be unloaded normally.

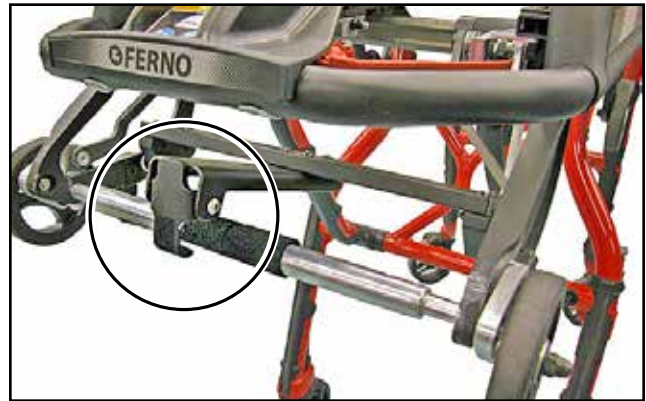

Figure 11 - Safety-Lock Device

### 4.12 Leg Lock (Blue Lever, Optional)

- **Purpose:** Allows the transporter to be carried (without the legs ratcheting down) by locking both transporter legs in Bed Position 1 or 3. Use additional help as needed (See *Bed Positions*, page 9 and *Using Additional Help*, page 23).
- **Location:** Transporter control end (Figure 12).
- **Use:**
  - **Both Operators:** Verify the stretcher is locked on the transporter.
  - **Both Operators:** Raise or lower the transporter to Bed Position 1 or 3. See *Bed Positions*, page 9.
  - **Control-end Operator:** Engage the leg lock by pulling the blue leg lock lever toward the control end of the transporter.
  - **Both Operators (and Helpers, if needed):** Lift and carry the transporter, stretcher and patient. See *Carrying the Transporter*, page 22 for complete instructions.
  - **Both Operators:** Set the transporter down when you reach your destination.
  - **Control-end Operator:** Disengage by pushing the blue leg lock lever toward the loading end of the transporter.



Figure 12- Leg Lock Lever

#### Important

If the legs do not unfold as the transporter is removed from the ambulance, check the leg lock. Push the transporter back inside the ambulance, release the lock, and start the unloading process again. Do not force the legs down.



## 5 - USING THE TRANSPORTER

### 5.1 Before Placing the Transporter in Service

- Personnel who will work with the transporter need to read this manual and the manuals for the stretcher(s) and fastener to be used with the transporter.
- Confirm that the transporter operates properly. See *Inspecting the Transporter*, page 25.
- The vehicle must have a Ferno fastening system installed.

### 5.2 General Guidelines for Use

- Medical advice is beyond the parameters of this manual.
- It is the users' responsibility to ensure safe practices for the patient and themselves.
- A minimum of two trained operators is required.
- Follow standard emergency patient-handling procedures when operating the transporter.
- **Operators work together and maintain control of the transporter at all times.**
- Operators communicate with one another and use coordinated movements to operate the transporter.
- Lift only the weight you can safely handle. Use additional help when working with heavy loads (patient and equipment). For placement of helpers, see *Using Additional Help*, page 23.
- Stay with the patient at all times.
- Always use patient restraints to secure the patient on the transporter.
- When changing the transporter position (height) or when unloading it from an ambulance, verify that both sets of legs have locked before you release your grasp on the main frame.
- For details on using the stretcher and fastener system, see the users' manuals for these products.

#### **WARNING**

**Improper operation can cause injury. Operate the transporter only as described in this manual.**



Read the Users'  
Manuals



Operation Requires  
Two Trained Operators



Load Limit

#### **WARNING**

**An unattended patient can be injured. Stay with the patient at all times.**

#### **WARNING**

**An unrestrained patient can fall off the transporter and be injured. Use restraints to secure the patient on the transporter.**

### 5.3 Attaching and Removing A Stretcher

The transporter is designed for use with many Ferno® stretchers and stretcher chairs (see list on page 7). The stretcher can be locked onto the transporter with the patient's head at either end of the transporter.

A stretcher locks onto the transporter when the strike pins on the bottom of a stretcher engage the slam latches on the transporter (Figure 13).

#### ATTACHING THE STRETCHER

1. Lock the wheel locks to help hold the transporter stationary.
2. **Both Operators:** Lift the stretcher and position the stretcher slightly toward the control end of the transporter (Figure 14). Use additional help as needed to control the load (see *Using Additional Help*, page 23).
3. **Both Operators:** Align the stretcher glides with the transporter main frame and set the stretcher on the transporter main frame.
4. **Both Operators:** Roll the stretcher toward the loading end of the transporter until the stretcher strike pins fully engage in the transporter slam latches.

**Note:** As an alternative when the transporter is on flat, level floors or ground, the Loading-end Operator may grasp the transporter main frame and hold it steady as the Control Operator pushes the stretcher into the slam latches.

5. **Control Operator:** Verify that the stretcher is locked by attempting to pull it toward the control end of the transporter. If the locks have engaged, the stretcher will remain fixed on the transporter. If the locks have not engaged, repeat Steps 2-4.
6. **Control Operator:** Release the wheel locks before rolling the transporter.

#### REMOVING THE STRETCHER

1. **Both Operators:** As the Control Operator pushes the yellow stretcher-release handle on the transporter (Figure 15), both operators move the stretcher slightly toward the control end of the transporter to move the strike pins out of the slam latches.
2. **Control Operator:** Let go of the stretcher-release handle when the stretcher has cleared the strike pins.
3. **Both Operators:** Together, lift the stretcher off the transporter. Use additional help as needed to control the load (see *Using Additional Help*, page 23).

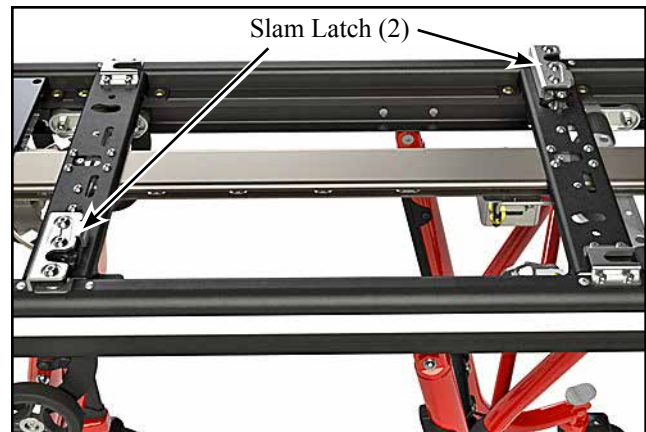

Figure 13 - Slam Latches on Transporter

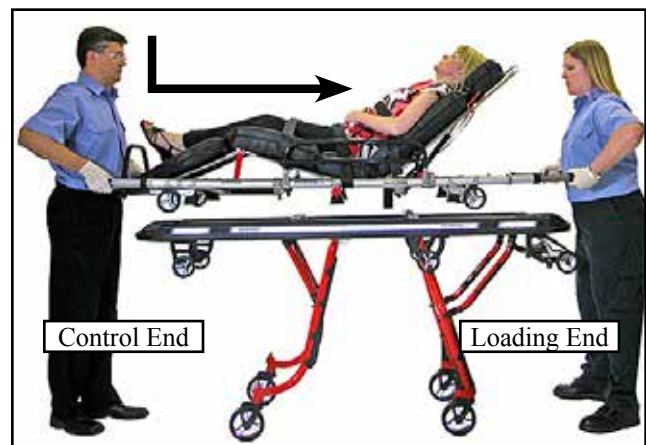

Figure 14 - Attaching the Stretcher

#### WARNING

An improperly secured stretcher can separate from the transporter and cause injury. Attach the stretcher securely and verify that the slam latches have locked.



Figure 15 - Stretcher Release Handle

## 5.4 Changing Transporter Positions

Changing transporter positions when a patient is on the transporter requires a minimum of two trained operators working together.

### BEFORE CHANGING TRANSPORTER POSITIONS

1. Engage the loading-end caster swivel locks so the wheels will not swivel. See *Swivel-Lock Release Lever*, page 11.
2. **Both Operators:** Stand at opposite ends of the transporter (Figure 16).
3. **Both Operators:** Use an underhand (palms up) grip to grasp the transporter main frame and position your right hand to use the leg-control handle (if needed).

### RAISING THE TRANSPORTER

The operators do not need to use a control handle when raising the transporter.

1. **Both Operators:** Lift the transporter until it is near the desired height. If the legs remain locked in Bed Position 1 or Bed Position 3 when you attempt to raise the transporter, disengage the leg lock (See *Leg Lock*, page 14).
2. **Both Operators:** Verify that the transporter has locked at the new height before relaxing your grasp.
3. If the legs have not locked, raise the transporter a little higher until you hear an audible “click” from the locking mechanism, then retest.

### LOWERING THE TRANSPORTER

1. **Both Operators:** Squeeze and hold the leg control handle with your right hand.
2. **Both Operators:** Lift the transporter slightly to take the weight off the locking mechanism and allow the locking mechanism to disengage. The leg-status indicator will change to red (See *Leg-Status Indicator*, page 10).
3. **Both Operators:** Together, lower the transporter (Figure 16). If the legs remain locked in Bed Position 3 when you attempt to lower the cot, disengage the leg lock (see *Leg Lock*, page 14).
4. **Both Operators:** Release the leg control handles when the transporter is near the desired height. Continue lowering until the locking mechanism engages.
5. **Both Operators:** Do not relax your grasp until you are sure the undercarriage is locked at the new position. To test:
  - After releasing the control handles, press down on the transporter main frame to verify the transporter does not continue to lower.
  - If needed, raise the transporter until you hear an audible “click” from the locking mechanism.

**Tip**

### Changing Positions

Operators should expect and be prepared to control the normal downward movement of the transporter which occurs when a control handle is squeezed.



Figure 16 - Raising or Lowering the Transporter

## 5.5 Transferring the Patient

### BEFORE TRANSFERRING THE PATIENT

- Place the transporter as close as possible to the patient to minimize lifting and moving. Adjust the transporter to the level of the patient.
- or**
- Remove the stretcher from the transporter (See *Attaching and Removing a Stretcher*, page 16) and place the stretcher next to the patient. See the stretcher users' manual for instructions on using the stretcher.

If you choose to leave the stretcher attached to the transporter for the transfer:

1. Unfasten the restraints and arrange the straps so they will not interfere with transferring the patient onto the transporter (Figure 17).
2. Lower the sidearms, retract the side lift handles, and engage the wheel locks.
3. Transfer the patient onto the transporter using approved emergency medical procedures and following your local protocols.
4. Raise the sidearms, adjust the backrest and shock frame as needed.
5. Fasten and adjust the patient restraints.
6. Disengage the wheel locks.
7. Before moving the transporter or changing its position, verify that sheets and other articles are positioned where they will not interfere with transporter operation.
8. Raise the transporter to a rolling position.

### Tip

#### Load Limits

The transporter is designed to hold the weight of a stretcher and patient. Use the stretcher load limit to determine the maximum patient weight permitted. Do not exceed the stretcher load limit.



**Figure 17 - Transferring the Patient**



## 5.6 Rolling the Transporter

### GENERAL GUIDELINES

- Rolling the transporter with a patient on it requires a minimum of two trained operators who are communicating, working together, and maintaining control of the transporter at all times.
- Use Position 5 or Position 6 to roll the transporter. Note that the transporter must be in Position 6 to unlock the loading-end caster swivel locks.
- Roll the transporter on smooth, unobstructed surfaces whenever possible.
- To cross a low obstacle such as a door sill, lift the transporter slightly to take the weight off the wheels so the wheels roll smoothly over the obstacle.
- Lift and carry the transporter over a high obstacle such as a curb. **Do not** apply downward force on one end of the transporter in order to raise the other end of the transporter.
- If the transporter is equipped with the auxiliary leg lock, the operators may fold the transporter and carry it. See *Carrying the Transporter*, page 22.
- Do not roll the transporter sideways. Rolling a transporter sideways can increase the chance for the transporter to tip and injure the patient and/or operators.
- Use additional help as needed to safely control the weight of the patient and transporter (see *Using Additional Help*, page 23).
- When rolling over rough terrain, the operators (and helpers) should grasp the main frame with both hands.

### ROLLING THE TRANSPORTER

1. Securely fasten the restraints around the patient.
2. **Both Operators:** Place the transporter at Bed Position 6 and unlock the control-end wheel locks. Use the swivel function on the loading-end wheels, if appropriate. Follow your local protocols.

**Note:** *If you are rolling the transporter in the control-end direction, the loading-end operator should unlock the loading-end caster wheels for swiveling.*

3. **Both Operators:** Position yourselves at the sides of the transporter near the patient’s torso, or at the loading and control ends of the transporter (Figure 18).

Grasp the main frame with both hands, communicate with one another, and attend the patient as you roll and steer the transporter.

### WARNING

Rolling the transporter sideways can cause the transporter to tip and injure the patient or operators. Roll the transporter only with the head-end or foot-end first.

### Tip

#### Rolling Downhill

Roll the transporter downhill operator-end first. If it is not medically appropriate to do this, roll the transporter with the loading end first **and** have the Loading-end Operator exert upward force on the main frame to help maintain transporter balance.



Figure 18 - Rolling the Transporter

## 5.7 Loading the Transporter

Loading the transporter with a patient on it requires a minimum of two trained operators who are communicating, working together, and maintaining control of the transporter at all times.

**Note:** Use additional help as needed when working with heavy loads (patient and equipment). See *Using Additional Help*, page 23.

1. If the ambulance has a folding tray, lower the ramp.
2. **Both Operators:** Raise the transporter to its highest bed position. Verify that the loading-end swivel casters are locked so they will not swivel during loading.
3. **Loading-end Operator:** Stand at the side of the transporter, grasp the main frame, and assist the Control-end Operator in loading the transporter into the ambulance.
4. **Control-end Operator:** Grasp the transporter main frame using an underhand (palms up) grip and begin pushing the transporter into the ambulance. Roll the transporter forward until both loading wheels are on the patient compartment floor (or tray) and the loading-end legs contact the bumper. The loading-leg lock will automatically begin to fold (Figure 19).

**Note:** If the transporter is equipped with the EZ Load™ automatic control-end leg release, the Control Operator may grasp the stretcher frame or telescoping handles to push the transporter into the ambulance.

5. **Both Operators:** Before the rear legs contact the ambulance bumper, lift and assume the remaining weight of the transporter, patient and equipment.
6. **Control-end Operator:**
  - **If the transporter is NOT equipped with the EZ Load™ automatic control-end leg release:** Squeeze the leg control handle to allow the control-end legs to unlock and fold. Continue pushing the transporter into the ambulance as the legs fold (Figure 20).
  - **If the transporter is equipped with the EZ Load™ automatic control-end leg release:** The control-end legs will automatically unlock and fold after the loading-end legs have folded. Continue pushing the transporter into the ambulance.
7. **Either Operator:** Secure the transporter in a fastener system. Fold the folding tray ramp if needed.



**Figure 19 - Loading the Transporter**



**Figure 20 - Loading the Transporter**



## 5.8 Unloading the Transporter

Unloading the transporter with a patient on it requires a minimum of two trained operators who are communicating, working together, and maintaining control of the transporter at all times.

**Note:** Use additional help as needed when working with heavy loads (patient and equipment). See *Using Additional Help*, page 23.

1. If the ambulance has a folding tray, lower the ramp.
2. Release the transporter from the fastener system.
3. **Control-end Operator:** Grasp the main frame with an underhand (palms up) grip. Roll the transporter out of the ambulance until the control-end legs unfold and lock.
4. **Control-end Operator:** Verify that the control-end legs have locked (Figure 21) by checking that the legs have finished swinging to their final, locked position and checking the leg status indicator.

### Important

If the legs do not unfold as the transporter is removed from the ambulance, check the leg lock (See *Leg Lock*, page 14). Push the transporter back inside the ambulance, release the lock, and start the unloading process again. Do not force the legs down.

### Important

If the ambulance is in a low area or on an incline, the operators (and any helpers) may need to lift the transporter to allow each set of legs to lock.

5. **Loading-end Operator:** As the transporter is pulled from the ambulance, grasp the transporter main frame and assist the Control-end Operator.
6. **Control-end Operator:** Pull the transporter out of the ambulance until the loading-end legs unfold completely and lock (Figure 22).
7. **Loading-end Operator:** Place one foot against the wheel of the loading-end legs and verify that the legs have finished swinging to their final, locked position.
8. **Both Operators:** Roll the transporter out of the ambulance.

### SAFETY-LOCK DEVICE REMINDER

During unloading, transporters equipped with the optional Safety-Lock Device may catch on a catch plate. If this happens, raise the transporter control end high enough for both sets of legs to unfold and lock, using additional help as needed. This will allow the transporter to be removed from the catch plate. See *Safety-Lock Device*, page 14.



**Figure 21 - After the Control-End Legs Unfold, Check the Indicator to Verify the Legs Have Locked**

### WARNING

**An unlocked undercarriage can cause injury. Before removing the transporter from the ambulance, confirm that both sets of legs unfold completely and lock.**



**Figure 22 - Unloading the Transporter**

## 5.9 Carrying the Transporter

The transporter legs can be locked in the lowest or mid-bed position so the operators can lift and carry the transporter over rough terrain or obstacles. To carry the transporter:

1. **Both Operators:** Raise or lower the transporter to Bed Position 1 or 3.
2. **Control-end Operator:** Engage the leg lock by pulling the blue leg lock lever toward the control end of the transporter (Figure 23).
3. **Both Operators (and any helpers):** Grasp the main frame and lift and carry the transporter (Figure 24).

To disengage the leg lock:

1. **Both Operators:** Set the transporter on the ground or flat surface.
2. **Control-end Operator:** Disengage the leg lock by pushing the blue lever toward the loading end of the transporter.

**Note:** Do not engage the leg lock while the transporter is loaded in an ambulance. Disengage the lock before loading the transporter into an ambulance.

**Note:** The transporter cannot be loaded into an ambulance in the folded position. Set the transporter down, disengage the leg lock, and raise the transporter fully. Then follow the standard loading process (See Loading the Transporter, page 20).

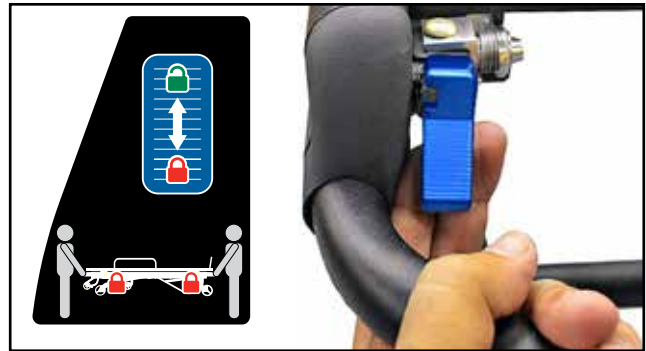

Figure 23 - Leg Lock Lever



Figure 24 - Carrying the Transporter

## 5.10 One Operator, Empty Transporter

**Changing Positions:** When the transporter is empty (no patient), one operator can change the transporter height. To raise the transporter, raise one end of the transporter, then the other.

To lower the transporter, squeeze the leg-control handle at one end of the transporter and lower the transporter to the desired position (Figure 25), then move to the opposite end and repeat the process.



Figure 25 - One Operator Changing Positions

If equipment is on the transporter, raise or lower the transporter in stages by adjusting the height only one or two positions at a time. This will help keep loose items from sliding off the transporter.

**Loading/Unloading:** If local protocols permit, an empty transporter may be loaded into and unloaded from the ambulance by one trained operator (Figure 26). Follow the procedures in *Loading the Transporter*, page 20 and *Unloading the Transporter*, page 21.



Figure 26 - One Operator Loading or Unloading

### 5.11 Using Additional Help

Operating the transporter requires a minimum of two trained operators. They may need additional help when working with heavy loads (patient plus equipment).

- Operators stand at the loading-end and control-end of the transporter, maintain control of the transporter, operate the controls, and direct all helpers.
- Side helpers may need to walk sideways under some circumstances. Follow local protocols.
- Ferno recommends that helpers work in pairs to help maintain transporter balance.

The chart below shows suggested placement for operators and helpers.

**⚠ WARNING**

**Helpers can cause injury or be injured. Maintain control of the transporter, operate the controls, and direct all helpers.**



**Load Limit**

Inspect the transporter if the load limit has been exceeded (See *Inspecting the Transporter*, page 25).

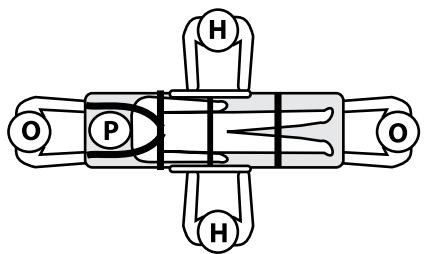
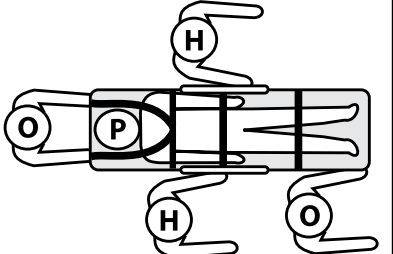
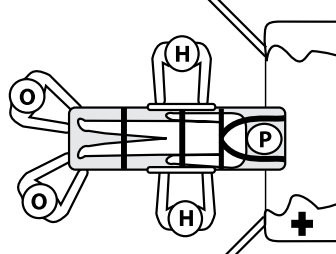
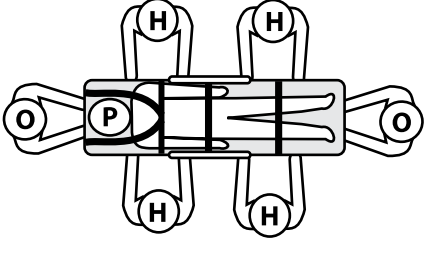
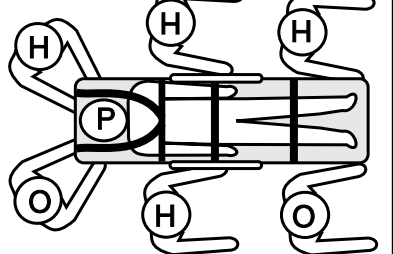
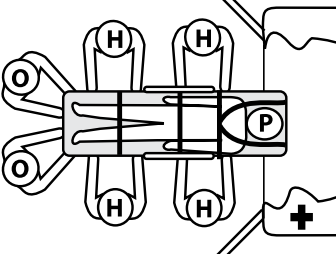
Helpers	Changing Positions	Rolling	Loading/Unloading
<b>Two Operators + Two Helpers</b>			
<b>Two Operators + Four Helpers</b>			

**Key: O = Operator H = Helper P = Patient**

## 6 - MAINTENANCE

### 6.1 Maintenance Schedule

The transporter requires regular maintenance. Set up and follow a maintenance schedule. The table at right represents minimum intervals for maintenance. Also refer to the *Recommended Routine Parts Replacement Schedule* on this page.

Keep maintenance records. A sample maintenance record sheet is provided on page 28.

When using maintenance products, follow the manufacturers' directions and read the manufacturers' material safety data sheets. You can purchase a recommended disinfectant from your Ferno distributor.

<b>⚠ WARNING</b>
<b>Improper maintenance can cause injury. Maintain the transporter only as described in this manual.</b>

Minimum Maintenance Intervals	Each Use	As Needed	Each Month
<b>Disinfecting</b> (page 25)	•		
<b>Cleaning</b> (page 25)		•	
<b>Waxing</b> (page 25)		•	
<b>Inspecting</b> (page 25)		•	•
<b>Lubricating</b> (page 26)		•	

### 6.2 Tracker™ (Optional)

The optional Tracker™ device is attached to the undercarriage and counts transporter cycles. A cycle is recorded each time the transporter moves from the folded position to a raised position and back. The total number of cycles is displayed on an LCD readout (Figure 26).

Use the Tracker™ as an aid to schedule and record transporter maintenance.

**Note:** *The Tracker™ is designed to maintain a count of the total number of transporter cycles. It is not designed to be reset to zero.*



**Figure 26 -Tracker™**

<b>RECOMMENDED ROUTINE PARTS REPLACEMENT SCHEDULE</b>
<p>Inspect and replace the transporter parts listed below at the proper time or cycle count, whichever comes first. To order kits, see <i>Parts and Service</i>, page 27.</p> <p><b>AS NEEDED</b></p> <ul style="list-style-type: none"> <li>• 100 mm Loading wheel [190-2034]</li> <li>• 150 mm Transport wheel [190-2044]</li> <li>• Scuff strips [190-2035; 190-2043; 190-2045; 190-2047]</li> </ul> <p><b>EACH YEAR OR 5,000 CYCLES</b></p> <ul style="list-style-type: none"> <li>• Loading-leg return spring [190-2041]</li> <li>• Control-leg return spring [190-2037]</li> </ul> <p><b>EVERY 3 YEARS OR 15,000 CYCLES</b></p> <ul style="list-style-type: none"> <li>• Loading-end wheel caster (2) [190-2038]</li> <li>• Loading-end swivel-lock pin and spring (2 ea.) [190-2054]</li> <li>• Control-end wheel caster w/lock (2) [090-5922]</li> <li>• Control-end wheel-lock lever, spring, and paddle (2) [190-2036]</li> </ul> <p><b>EVERY 4 YEARS OR 20,000 CYCLES</b></p> <ul style="list-style-type: none"> <li>• Leg control box assembly (2) [090-5919]</li> <li>• Loading-leg lock spring (2) [190-2043]</li> <li>• Center control box assembly [090-5920] <i>(if transporter is equipped with control-end leg auto-release mechanism)</i></li> <li>• Control-end leg auto-release lever assembly and spring [090-5921] <i>(if transporter is equipped with control-end leg auto-release mechanism)</i></li> </ul>



### 6.3 Disinfecting the Transporter

Wipe all surfaces with disinfectant. Follow the disinfectant manufacturer's instructions for application method and contact time. Ferno recommends you inspect the transporter for damage as you disinfect it.

### 6.4 Cleaning the Transporter

1. Remove the restraints, mattress and any accessories.
2. Hand clean all surfaces of the transporter with warm water and a mild detergent.
3. Rinse with warm, clear water. Dry the transporter with a towel or allow it to air-dry.

### 6.5 Waxing the Transporter

While it is not necessary to wax this transporter, waxing the aluminum main frame or the painted legs will not damage them, and will help maintain the transporter's appearance.

Disinfect and clean the transporter before applying wax. Use an automotive wax as directed by the wax manufacturer.

### 6.6 Inspecting the Transporter

Have your service's equipment maintenance personnel inspect the transporter regularly. Follow the checklist at right and operate the transporter through all its functions as described in this manual.

If inspection shows damage or excessive wear, remove the transporter from service until repair is made. See *Parts and Service*, page 27.

#### Important

Disinfectants and cleaners containing bleach, phenolics, or iodines can cause damage. Do not use products containing these chemicals.

#### Important

Water under high pressure, or steam, can penetrate joints, flush away lubricant, and cause corrosion. Use caution when cleaning moving parts such as joints and hinges, and reapply lubricant if needed (see page 26).

#### Important

Using abrasive cleaning compounds or applicators on the transporter can cause damage. Do not use abrasive materials to clean the transporter.

#### INSPECTION CHECKLIST

- Are all components present?
- Is the transporter free of excessive wear?
- Are all screws, nuts, bolts and rivets securely in place?
- Inspect all visible springs. Is there any visible damage?
- Do all moving parts operate smoothly and properly?
- Does the transporter lock properly into each position?
- Does the stretcher attach securely to the transporter?
- Does the transporter load and unload properly?
- Does the transporter roll smoothly?
- Are the wheels free of excessive wear?
- Do the wheel locks engage properly and stop wheel rotation?
- Is the ambulance properly prepared for the transporter with an approved Ferno fastener system installed?
- Do installed accessories operate properly without interfering with transporter operation?

### 6.7 Lubricating the Transporter

Disinfect and clean the transporter before applying lubricant. Use the lubricants designated at right to lubricate the transporter. Do not lubricate points marked with the “do not lubricate” symbol.



**Do Not Lubricate**



**Lubricate**

#### Important

Lubricating parts that should not be lubricated allows dirt and foreign particles to collect on those parts, resulting in damage. Lubricate **only** the numbered reference points shown.

#### LUBRICATION POINTS

Use a small amount of lubricant. Lubricate identical points on each side of the transporter.

- |                              |                               |
|------------------------------|-------------------------------|
| 1. Slam latch spring (2)     | WRL-191S or E-Z-1 (1-2 drops) |
| 2. Loading-wheel linkage (4) | WRL-191S or E-Z-1 (1-2 drops) |

#### LUBRICATION-FREE ITEMS

- |                                      |                  |
|--------------------------------------|------------------|
| Channel <sup>1</sup>                 | Do not lubricate |
| Rollers                              | Do not lubricate |
| Wheels (sealed bearings)             | Do not lubricate |
| Leg pivot points                     | Do not lubricate |
| Swivel-caster lock pins <sup>2</sup> | Do not lubricate |

<sup>1</sup> The channels do not require lubrication. Lubricating the channels or rollers will cause foreign particles to stick to the rollers and channel, causing damage.

<sup>2</sup> Clean only with mild detergent and water.

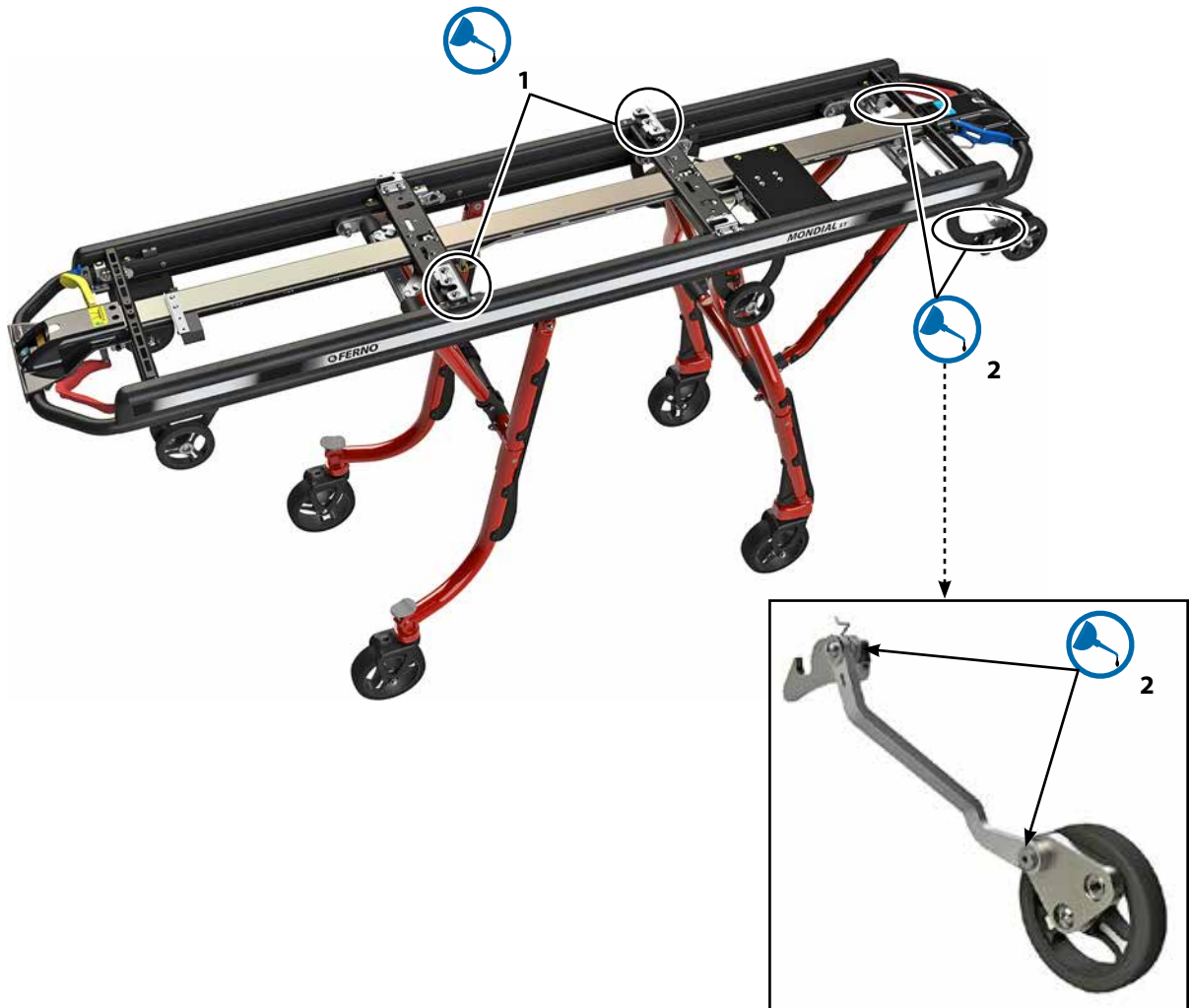



## 7 - PARTS, SERVICE, AND ACCESSORIES

### 7.1 Parts and Service

To order Ferno parts, and for professional transporter repair, contact your Ferno distributor. Your distributor is the only agent authorized by Ferno to manage, service, and repair Ferno products.

 **WARNING**

**Improper parts and service can cause injury. Use only Ferno parts and Ferno-approved service on the transporter.**

 **WARNING**

**Modifying the transporter can cause injury and damage. Use the transporter only as designed by Ferno.**

Kit	Description
083-2239	Mondial Conductive wheel kit (set/4 wheels)
190-2034	Mondial Trispoke 100 mm wheel w/hardware
190-2035	Mondial Control-end leg scuff strip w/hardware
190-2036	Mondial Wheel Lock
190-2037	Control-end leg return spring
190-2038	Loading-end wheel fork (no wheel)
190-2039	Mondial fastener crosstube weldment w/hardware
190-2040	Mondial Loading-end wheel axle w/hardware
190-2041	Mondial Loading-leg return spring w/hardware
190-2042	Mondial Loading-end leg bumper
190-2043	Loading-end leg lock torsion springs
190-2044	Mondial Trispoke 150 mm wheel w/hardware
190-2045	Mondial leg brace scuff strips w/hardware
190-2046	Mondial ST70 loading-leg scuff strips w/hardware
190-2047	Mondial ST64 loading-leg scuff strips w/hardware
190-2048	Mondial Trans. loading-end slam latch w/hardware
190-2049	Mondial Trans. leg-release handle (Red)
190-2050	Mondial Trans. stretcher-release paddle (Yellow)
190-2051	Mondial Trans. swivel-release paddle (Blue)
190-2052	Mondial Trans. control-end slam latch w/hardware
190-2053	Mondial Trans. loading-wheel shank glider (pr.)
190-2054	Mondial Trans. swivel release pin, spring
190-2055	Mondial Loading wheel w/hardware
090-5922	Mondial Control-end wheel fork w/wheel lock
090-5919	Mondial Control-box assembly (load or control end)
090-5920	Mondial Center control-box assembly
090-5921	Mondial Control-end leg auto-release assy. w/spring
082-2418	Touch-up paint, green
082-2419	Touch-up paint, silver
081-9977	Touch-up paint, black
081-9972	Touch-up paint, red

### 7.2 Accessories

Ferno offers a full line of emergency medical service accessories. Follow all instructions packed with accessories. Keep the instructions with this manual. When using accessories, be aware of any special considerations such as doorway heights and widths, etc. Contact Ferno Customer Relations (page 2) or your Ferno distributor for product information.

 **WARNING**

**Attaching improper items to the transporter can cause injury. Use only Ferno-approved items on the transporter.**

#### MONDIAL® SERIES ACCESSORIES

Description	Kit
FL1 Fastener	057-3080
Mondial® Safety Lock Device	083-2164
Mondial® Tracker™	083-2165
RS2, RS3, RS4 Mattress, bolstered	037-4874
RS2, RS3, RS4 Mattress, flat	037-4875
RS2, RS3, RS4 Storage tray	083-2166
RS2, RS3, RS4 DIN-pin kit (Germany)	083-2167
EFX or Mondial® IV pole	083-2024

#### EFX SERIES STRETCHERS

EFX Stretcher to Mondial® Conversion Kit	083-2175
--	----------

<b>TRAINING RECORD</b>		
<b>Date</b>	<b>Name</b>	<b>Training Method</b>

<b>MAINTENANCE RECORD</b>		
<b>Date</b>	<b>Maintenance Performed</b>	<b>By</b>