

NPC3 & NPC3SG

Piezo Controllers



Newport®

Experience | Solutions



User's Manual

For Motion, Think Newport™

Table of Contents

Waranty	iv
EU Declaration of Conformity	v
Safety Prautions.....	vi
Warnings and Cautions	viii
<hr/>	
1.0 NPC3 and NPC3SG	1
<hr/>	
2.0 Key Words	2
<hr/>	
3.0 Introduction.....	4
3.1 NPC3SG Controller with Integrated Feedback Controller System	4
3.2 NPC3 without Feedback Controller	5
<hr/>	
4.0 Initiation	5
<hr/>	
5.0 User Elements/Connection	5
5.1 Front Panel.....	5
5.2 Rear Panel.....	5
<hr/>	
6.0 Handling	6
6.1 Main Supply Voltage.....	6
6.2 Connecting Piezo Actuator	6
6.3 Graphic Display	6
6.4 Manual Control	7
6.5 Controlling Via Modulation/Monitor	7
6.5.1 Monitor NPC3SG.....	7
6.5.2 Monitor NPC3.....	7
6.6 Controlling Via Interface.....	7
6.6.1 Configuration RS-232	8
6.6.2 Command List.....	8
cloop (👉)	9
ERR?	9
fenable	9
fready.....	10
light	10
measure.....	10
monwpa	11
rk	11

set	11
setall	12
setk	12
ver.....	12
6.6.3 Example	12
6.6.4 Calibration of Encoder	13
6.6.5 Encoder Commands Generally	13
6.6.6 Special Commands for Encoder.....	14
<hr/>	
7.0 Technical Data.....	15
<hr/>	
8.0 Pinouts	16
8.1 Sub-D15 Male Output Connectors for Actuators	16
8.2 Sub-D25 Femal Connector for Modulation/Monitor	16
8.3 Sub-D9 Femal Connector for RS-232	17
8.4 USB1.1 Connector	17
8.5 Main Supply Voltage Connector.....	17
<hr/>	
9.0 Troubleshooting	18
<hr/>	
Service Form	19

Warranty

Newport Corporation warrants this product to be free from defects in material and workmanship for a period of 1 year from the date of shipment. If found to be defective during the warranty period, the product will either be repaired or replaced at Newport's discretion.

To exercise this warranty, write or call your local Newport representative, or contact Newport headquarters in Irvine, California. You will be given prompt assistance and return instructions. Send the instrument, transportation prepaid, to the indicated service facility. Repairs will be made and the instrument returned, transportation prepaid. Repaired products are warranted for the balance of the original warranty period, or at least 90 days.

Limitation of Warranty

This warranty does not apply to defects resulting from modification or misuse of any product or part. This warranty also does not apply to fuses.

This warranty is in lieu of all other warranties, expressed or implied, including any implied warranty of merchantability or fitness for a particular use. Newport Corporation shall not be liable for any indirect, special, or consequential damages.

First printing 2009

© 2012 by Newport Corporation, Irvine, CA. All rights reserved. No part of this manual may be reproduced or copied without the prior written approval of Newport Corporation. This manual is provided for information only, and product specifications are subject to change without notice. Any change will be reflected in future printings.

EU Declaration of Conformity

NPC3 & NPC3SG



Piezo Amplifier

Year  mark affixed: 2009

EC Declaration of Conformity

We declare that the accompanying product, identified with the " " mark, complies with requirements of the Electromagnetic Compatibility Directive, 2004/108/EC and the Low Voltage Directive 2006/95/CE.

TYPE OF EQUIPMENT:

Electrical equipment for measurement, control and laboratory use.

STANDARDS APPLIED:

Compliance was demonstrated to the following standards to the extent applicable:

- IEC 61010-1
- EN 55011, part 11, group 1, class B
- EN 50082, part 2

01/09/2009

Dominique DEVIDAL
Quality Manager
Zone Industrielle
45340 Beaune-la-Rolande, France

Safety Precautions

Definitions and Symbols

The following terms and symbols are used in this documentation.

European Union CE Mark



CE Mark.

The CE mark indicates that the equipment has been designed and tested to comply with all applicable European Union (CE) regulations.

“ON” Symbol



“ON” Symbol.

The “ON” Symbol appears on the power switch of the controller. This symbol represents the “Power On” condition.

“OFF” Symbol



“OFF” Symbol.

The “Off” Symbol appears on the power switch of the controller. This symbol represents the “Power Off” condition.

Warnings and Cautions

The following are definitions of the Warnings, Cautions and Notes that may be used in this manual to call attention to important information regarding personal safety, safety and preservation of the equipment, or important tips.



WARNING

Situation has the potential to cause bodily harm or death.



CAUTION

Situation has the potential to cause damage to property or equipment.

NOTE

Additional information the user or operator should consider.

Warnings

WARNING

Do not open the units! There are no user serviceable parts inside and opening or removing covers may expose you to dangerous shock hazards or other risks. Refer all servicing to qualified service personnel.

WARNING

Allow adequate ventilation around the units so that heat can properly dissipate. Do not block ventilated openings or place the units near a radiator, oven or other heat sources. Do not put anything on top of the units except those that are designed for that purpose (e.g. actuators).

WARNING

Do not spill any liquids into the cabinet or use the units near water.

WARNING

Do not insert objects of any kind into the cabinet slots, as they may touch dangerous voltage points, which can be harmful or fatal or may cause electric shock, fire or equipment failure.

WARNING

Do not place any heavy objects on any cables (e.g. power cords, sensor cables, actuator cables, optical cables). Damage may cause malfunction or shock or fire!



WARNING

Do not place the units on a sloping or unstable cart, stand or table as they may fall or not work accurately.

WARNING

Work with the units only in a clean and dry environment! Only specially prepared units (e.g. actuators) can work under other conditions!

WARNING

Please use only original parts from Newport.

WARNING

Newport does not give any warranty for damages or malfunction caused by additional parts not supplied by Newport. Additional cables or connectors will change the calibration and other specified data. This can change the specified properties of the units and cause them to malfunction.



WARNING

Piezoelements are sensitive systems capable of the highest positioning accuracy. They will demonstrate their excellent properties only if they are handled correctly! Please mount them properly only at the special mounting points.

Immediately unplug your unit from the wall outlet and refer servicing to qualified service personnel under the following conditions:

- When the power supply cord or plug is damaged.
- If liquid has been spilled or objects have fallen into the unit.
- If the unit has been exposed to rain or water.
- If the unit has been dropped or the housing is damaged.

Cautions

CAUTION

Piezoelectric actuators from Newport are controlled by voltages up to 150V. These values can be quite hazardous. Therefore read the installation instructions carefully and only authorized personal should handle the power supply.

CAUTION

After transportation, piezoelectric actuators should be allowed to adapt for approximately 2 hours to the room temperature before being switched on.

CAUTION

Piezoelectric actuators are made from ceramic materials with and without metallic casings. The piezo-ceramic is a relatively brittle material. This should be noted when handling piezoelectrical actuators. All piezo-elements are sensitive to bending or shock forces.

CAUTION

Due to the piezoelectric effect piezo-actuators can generate electrical charges by changing the mechanical load or the temperature or such actions described above.

CAUTION



Piezoelectric actuators are able to work under high compressive forces. Only actuators with a pre-load can be used under tensile loads (these tensile forces must be less then the pre-load, given in the data sheet).

CAUTION

Please note that the acceleration of the ceramic material (e.g., caused by fall down, discharging or high dynamic application) will occur.

CAUTION

After excitation of the actuators by a voltage in the upper control range, the ceramic will move and generate an opposite high voltage after disconnection.

CAUTION

Heating of the ceramic material will occur during dynamic operation and is caused by structure conditional loss processes. This may cause failure if the temperature exceeds specified values cited below.

CAUTION

The piezoelectric effect disappears at temperatures above the Curie temperature (usual values approx. 140...250°C).

CAUTION

Piezoelectric actuators such as stacks or other devices work electrically as a capacitor. These elements are able to store electrical energy over a long period of time (up to some days) and the stored energy may be dangerous.

CAUTION

If the actuator remains connected to the drive electronics, it is unloaded within a second after shutdown and quickly reaches harmless voltage values.



CAUTION

Piezo-actuators can generate voltages by warming or cooling only (caused by the longitudinal change). The discharge potential should not be ignored due to the inner capacitance. This effect is insignificant at usual room temperature.

CAUTION

Piezo-actuators from Newport are adjusted and glued. Any opening of the unit will cause misalignment or possible malfunction and the guarantee will be lost.

CAUTION

Please use only original parts from Newport.

CAUTION

Please contact Newport or your local representative, if there are any problems with your actuator or power supply.



CAUTION

Shock forces may damage the built-in ceramic elements. Please avoid such forces, and handle the units with care, otherwise the guarantee will be lost.

Piezo Controllers

NPC3 & NPC3SG



NPC3 and NPC3SG controllers.

1.0 NPC3 and NPC3SG

This manual describes NPC3 and NPC3SG digital piezo controllers from Newport. You will also find additional information regarding piezoelectric products.

NOTE

This instruction manual includes important information for using piezo actuators. Please take time and read this information. Piezo positioning systems are mechanical systems with highest precision. Correct handling guarantees the precision over long time.

NOTE

NPC3 and the NPC3SG controllers are very similar. In case of information which do refer to the NPC3SG this symbol will appoint it:

 NOT AVAILABLE IN NPC3.

2.0 Key Words

NPC3

Piezo controller for up to 3 piezo actuators; RS-232/USB interface; for piezo actuating systems without feed back sensor inside.

NPC3SG

Piezo controller for up to 3 piezo actuators; RS-232/USB interface; for piezo actuating systems with feed back sensors inside (strain gauge or capacitive).

Graphic Display

3.5" TFT full colour graphic display, 320x240 Pixel; constantly shows all values and status information.

Potentiometer Knob

For manual voltage offset adjustment and for switching on and off closed loop mode (NPC3SG only).

Closed Loop

Operating mode for piezo actuating systems with integrated feed back sensor system. Position accuracy is constantly controlled.

Open Loop

Operating mode for actuating systems without feedback sensor inside; no position information available.

Softstart

Special power-on procedure with a movement of the actuator over the complete stroke within 10 seconds. Softstart can be disabled by command in case the full movement of the actuator is not suitable or dangerous in the application.

PC Interface

Serial RS-232 interface or USB with 16bit resolution

Modulation Input

The controller can be controlled by an external analogue voltage signal from 0 V...10 V.

Monitor Output

Output voltage signal which corresponds with the position of the piezo actuating system (Closed Loop mode) or with the applied voltage signal (open loop mode).

Automatical Sensor Identification (ASI)

NPC3SG controller can be used with strain gauge feed back sensors as well as with capacitive feed back sensors. The ASI function makes it possible to show the name of the actuator and the measurement system.

Main Supply Voltage

The main supply voltage to the controller is 24 VDC; an external wide range power converter for 115–230 VAC is included in the shipment.

Remote Control

The remote control switches all manual controls (potentiometer knob and modulation) off or on. Please pay attention only if the remote control is switched on (1) it will be possible to use the “set” command. RS232 and USB ports support the communication between PC and the piezo controller.

Hyper Terminal Program

Enables to control the piezoactuating system by using the RS-232 interface. All necessary commands are given in the user manual.

3.0 Introduction

The controller module NPC3 and NPC3SG are designed for parallel control of up to three low voltage piezo actuators with and without internal feed back sensor system. The controller comes as a stand-alone device with standard PC interface RS-232 and USB. A graphic display constantly shows all status information such as voltage and motion. Each piezo can be controlled separately either by turning the voltage offset, by applying an analog voltage signal of 0...10 V or by PC interface. The voltage of the monitor output corresponds to either applied piezo voltage (NPC3) or completed motion (NPC3SG).

The NPC3 is designed for controlling only open loop actuating systems without any feed back sensor inside. The NPC3SG is designed for piezo actuating system with strain gauge or capacitive feed back sensors inside. In this case, the sensor signal is prepared by an external pre-amplifier inside the cable. The Automatical Sensor Identification "ASI" enables the customer to use the controller unit NPC3SG with different piezo actuators of the same product series. This enables the controller unit to read all system information from the actuating systems which are stored inside the connector and transmit this information to the controller unit.

3.1 NPC3SG Controller with Integrated Feedback Controller System

Analog actuating systems with integrated feedback sensors are calibrated with a particular controller unit. Only systems consisting of piezo and controller which are calibrated to each other can be used together to reach the full accuracy performance. Exchanging of actuating system is possible in this case only if the actuating system is from the same product group. Otherwise the closed loop controller can be damaged!

Example: If the controller NPC3SG is calibrated for NPO140SG series (range of motion 140 μm), then it can be used with different NPO140SG actuators, but not with NPO250SG (range of motion 250 μm).

If an actuator is connected to a channel of the controller NPC3SG which it was not calibrated with, it won't be possible using in closed loop.

Please note that the information about the operation mode (closed loop, open loop) are automatically stored if the system is switched off. When it is switched on again, the last operation mode is set again. The system starts automatically at the minimal position after it is switched on.

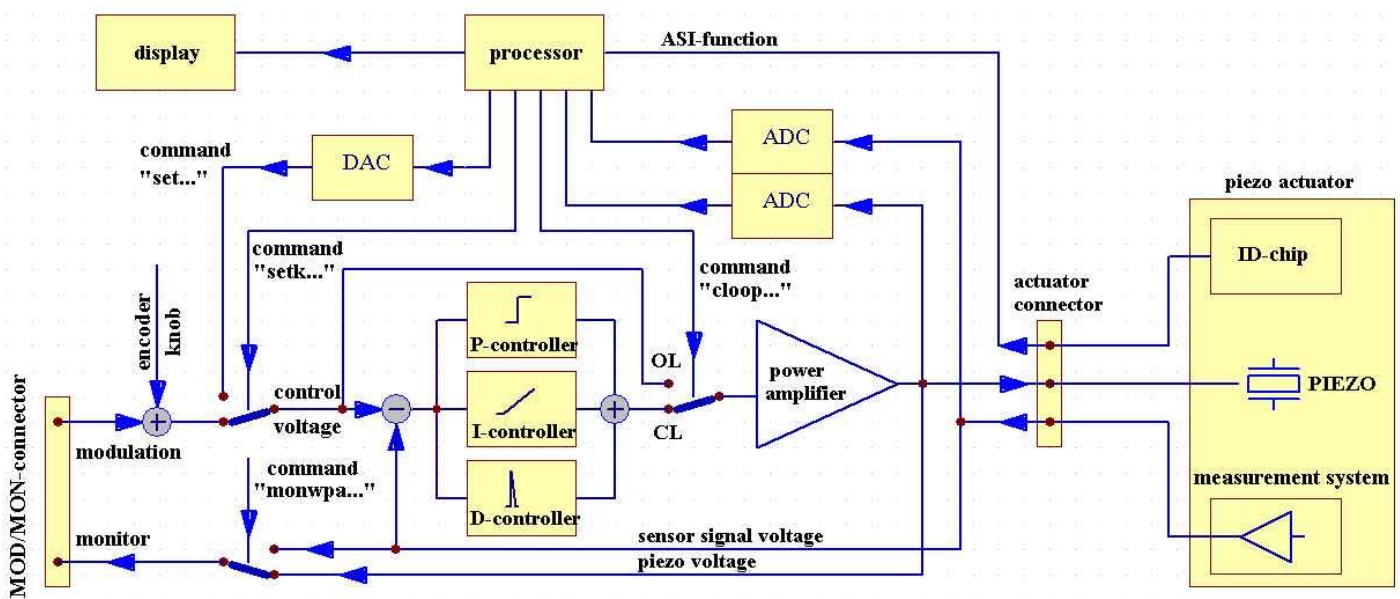

3.2 NPC3 without Feedback Controller

Please note that by switching on the controller the voltage signal is applied direct to the connected piezo actuating system. A shock voltage signal applied to the piezo actuating system can affect system's life time.

4.0 Initiation

Please follow all safety instruction given in previous chapters before using the controller.

5.0 User Elements/Connection

5.1 Front Panel

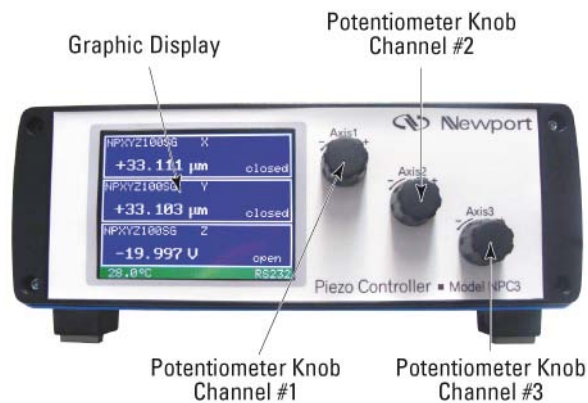

3,5" TFT full colour graphic display with adjustable brightness.

5.2 Rear Panel

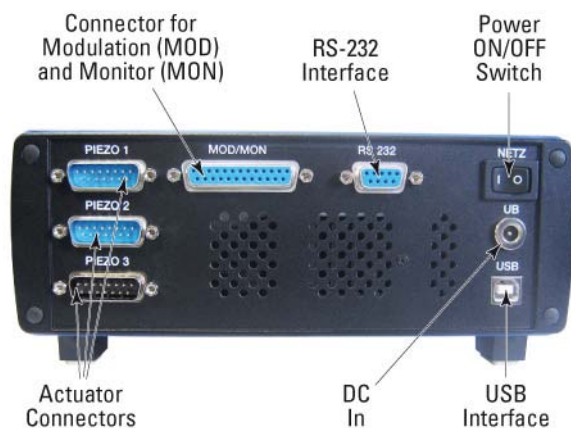

6.0 Handling

6.1 Main Supply Voltage

The controller NPC3 and NPC3SG require a main supply voltage of 24 VDC. A power supply unit suitable for voltage from 115 V/50 Hz up to 230 V/50 Hz AC is included in the shipment. The socket for the main supply voltage is located on the back panel of the controller.

6.2 Connecting Piezo Actuator

The piezo actuating systems is connected to the controller unit by using the Sub-D connector on the back panel. Please make sure that the controller is switched off by connecting the piezo with the controller. Please fasten the screws of the Sub-D connector and guarantee a firm connection. If the display shows the information “not connected” then please check the connection between piezo connector and controller again.

6.3 Graphic Display

The graphic display shows the following status information:

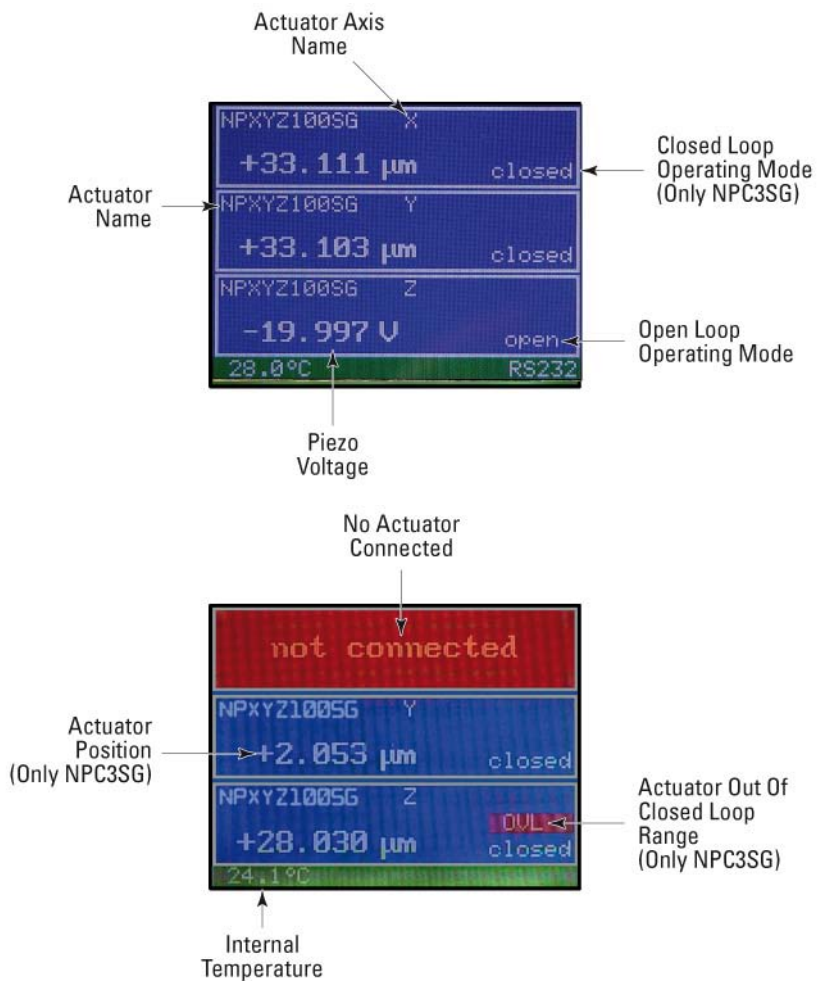

6.4 Manual Control

Each channel of the controller can be controlled by turning the potentiometer knob on the front panel. Turning clockwise increases the applied voltage signal, turning counterclockwise reduces the applied voltage signal.

the closed loop mode of the NPC3SG controller can be switched on and off by pressing the potentiometer knob for each channel. If you switch off the controller the operational mode (closed loop, open loop) will be saved, and after switching on, the controller starts again with its last operational mode.

6.5 Controlling Via Modulation/Monitor

The controller can be controlled by an external modulation signal from 0...10 V. An adapter cable with BNC to Sub-D connector is included. The modulation is marked on the back panel by MOD.

By using an external modulation signal in open loop mode 0 V correspond to a value of -20 V and 10 V correspond to voltages signal of 130 V applied to the piezo actuating system.

in closed loop mode 0 V corresponds to the a motion of $0\mu\text{m}$, 10 V correspond to the max. motion based on the specification of the used piezo actuating system.

Example: NPO140SG.

Position	Minimal	Maximal
Open Loop	0 V = -20 V	10 V = 130 V
Closed Loop	0 V = $0\mu\text{m}$	10 V = $140\mu\text{m}$

The actuating system will move (up to 20% of full motion) when switching on and off the closed loop mode (👉) because of different voltage signals.

6.5.1 Monitor NPC3SG

The monitor output of the NPC3SG provides a voltage signal which correspondents directly to the position of the piezo actuating system. The value for the monitor output voltage range is from 0 V to +10 V in closed loop mode and from -13 V to +13 V in open loop mode (minimum and maximum of motion range). The difference in both signal's values is caused by the closed loop control reserve.

6.5.2 Monitor NPC3

The monitor output of the NPC3 always provides a signal of 0 V up to 10 V which directly corresponds to the voltage signal applied to the piezo actuator. Based on this a signal of 0V is related to an applied voltage of -20 V and 10 V is related to 130 V.

6.6 Controlling Via Interface

For external control via PC, a USB or RS-232 interface can be used. Make sure that the controller is switched off before connecting with the PC. The interface on the back plane is marked with RS-232. A hyper terminal program can be used for control via serial interface RS-232. In order to use the USB interface, please install the driver software first. All commands are given in following chapter.

6.6.1 Configuration RS-232

For external control by PC interface RS-232 the following settings are necessary:

Baud rate/Bits per second	19200
Data bits	8
Stop bits	1
Parity	No
Flow control	Software (XON/XOFF)

For external control via RS-232, you may use the hyper terminal program of your PC.

6.6.2 Command List

CMD	Statement
cloop	Switch one channel to closed loop or open loop
encexp	Encoder: exp. For calc. of acceleration (EM0)
enclim	Encoder: max. step
encmode	Encoder: mode (EN)
encstcl	Encoder: interval for "closed loop" (EM1,2) (ϕ)
encstol	Encoder: interval for "open loop" (EM1,2)
enctime	Encoder: sample interval (SI)
ERR?	Switch one channel to closed loop or open loop
fenable	Gives the version number of controller and controller software
fready	Shows the last error
light	Select the display brightness
measure	Measures values of all channels either for position or voltage
monwpa	Switch the monitor in different modes
rk	Measures the value either of position (only NPC3SG) or voltage (only NPC3) only for one channel
set	Set the values to one channel
setall	Set the values to all channels
setk	Switch the remote control for one channel on or off
ver	Switch the remote control for one channel on or off

NOTE

The number of channels starts with "0". Connector "Piezo #1" equals channel number "0".

All commands which included a value have to be separated by dots. Example: The value 22,5 μm must be programmed by the command <22.5>.

cloop (👉)

Syntax	cloop,<ch>,<0 1>
Description	The command “cloop” switches channel of the controller (👉) to the operation mode closed loop <1> or to open loop <0>.
Return	None.
Example	cloop,1,0 <i>Channel #2 (Piezo #2) is set to the operation modus open loop.</i>

ERR?

Syntax	ERR?
Description	The command “ERR?” gives the last failure from the controller. After read out the error from the controller the failure status in the memory will be deleted. The output of the error message occurs as plain text.
Return	ERROR,<“last error“>
Example	ERR? <i>ERROR,"OK. No error."</i>

fenable

Syntax	fenable,<ch>,<0 1>
Description	This command “fenable” enables the soft start function for the given channel. After switching on the system the soft start function is started for 10seconds to initiate the actuator. While this routine the actuator is moved once through the whole motion range and back. While softstart the modulation input and the offset potentiometer are disabled. After the softstart the controller is working normally. If only the parameter for the channel set after the command “fenable” the controller gives back the status of softstart function for the channel.
Return	None.
Example	fenable,0,1 <i>The soft start function is switched on for the channel #0 (Piezo #1).</i>

fready

- Syntax** fready,<0|1>
- Description** This command “fready” enables the soft start function for all channels. After switching on the system the soft start function is started for 10seconds to initiate the actuator. While this routine the actuator is moved once through the whole motion range and back. While softstart the modulation input and the offset potentiometer are disabled. After the softstart the controller is working normally.
- If no parameter set after the command “fready” the controller gives the status of softstart function for all channels.
- Return** None.
- Example** fready,1
The soft start is switched on for all channels.

light

- Syntax** light,<0...255>
- Description** The command „light“ can be used to control the brightness of the display. Adjustable values are between “0” (display off) and “255” maximum brightness. The last adjustment will be stored and will be automatically used if the amplifier will be switched on. Command without value reads out the current value.
- Please pay attention! If the display remains dark after switching on the amplifier the display may have been adjusted to “light,0” before. Please read out the value by input command “light” and change the value if necessary.
- Return** None switch off the display .
- Example** light,0

measure

- Syntax** measure
- Description** The command “measure“ reads out either the position <value0..2> from the measurement system () or the voltage applied to the actuator. The read out values <value0..2> are given with 3 decimal places.
- Return** aw,<wert0>,<wert1>,<wert2>
- Example** measure
aw,0.015,5.003,150.002

monwpa

Syntax	monwpa,<0>,<0112>
Description	The command „monwpa” supports the output of different measurement sources from the piezo controller. A fixed choice is possible between the actuator voltage and the actuator position (NPC3SG only!). The monitor output is set depending on the operating mode, OL or CL (see Mode 0 and 1). Both modes are possible only with the NPC3SG, because it is a closed loop device.
Mode	<p>0 - Sets the monitor output always to the actuator voltage.</p> <p>1 - Sets the monitor output always to the actuator position.</p> <p>2 - Sets the monitor output to the actuator voltage in open loop and to the actuator position in closed loop.</p>
Return	None.
Example	monwpa,0,1

rk

Syntax	rk,<ch>
Description	The command “rk” reads out either the position <value> for one channel <ch> from the measurement system (👉) or the voltage applied to the piezo. The readout value <value> is given with 3 decimal places.
Return	rk,<ch>,<wert>
Example	rk,1 <i>rk,1,20.016</i>

set

Syntax	set,<ch>,<wert>
Description	The command “set” sets a channel <ch> to the given value <value>. In closed loop (🔒) the value means μm . In open loop the value means the voltage which is applied to the actuator. Please pay attention that the remote control has been switched on before.
Return	None.
Example	set,0,5.53 <i>Set the position of the actuator to the given value. In closed loop (only NPC3SG) the value is 5,53 μm. In open loop the value means 5,53 V.</i>

setall

- Syntax** setall,<wert0>,<wert1>,<wert2>
- Description** The command “setall” sets all channels to the given values <value>. In closed loop (👉) the value <value0..2> means μm . in open loop the value <value0..2> means the voltage which is applied to the actuator. Please take care that the remote control for all channels has to be switched on.
- Return** None.
- Example** setall,22,1.5,5.53
Sets the position of the actuator to the given value <value0..2>. For instance Piezo #1 to 22 and Piezo #2 to 1,5 and Piezo #3 to -5,53 (only possible if the operation mode open loop).

setk

- Syntax** setk,<ch>,<0|1>
- Description** The command setk switches the remote control for one channel <ch> on <1> or off <0>. If the remote control is activated you won't be able to change the position either by the potentiometer knob or via modulation. turning the remote control off, the position of the actuator goes to minimal position.
- Return** None.
- Example** setk,0,1
Set the actuator on channel #1 to remote control.

ver

- Syntax** ver
- Description** This Command “ver” reads out the software version number of the internal controller, the date and the serial number of the controller.
- Return** version,vnumber,vdate
- Example** ver
ver,1.000.799
sdate,11/09/2006
serno,23579

6.6.3 Example

This example shows the sequence of the commands to move the actuator with the NPC3SG from the minimal position $0 \mu\text{m}$ to $10 \mu\text{m}$:

Instruction	Return	Description
[Enter]	NPC3SG	After press the [Enter] key on the computer keyboard the prompt shows “NPC3SG>” in the hyper terminal program
setk,0,1	None	Activates the remote control on channel #1
cloop,0,1	None	Switches channel #1 to closed loop operating mode
set,0,10	None	Set channel #1 to $10 \mu\text{m}$
rk,0	rk,0,10.000	Measures Piezo connected to channel #1 stands at the position $10 \mu\text{m}$

6.6.4 Calibration of Encoder

The encoder of NPC3(SG) is used for the calibration of the attached actuator in open loop and closed loop. The encoder has a resolution of 30 detent/rotation.

With each step of the encoder a internal counter (**EncIncr**) within the scanning interval (**SI**), will be incremented or decremented, depending on the direction of rotation. After scanning intervall NPC3(SG) calculates a new stroke (👉) or voltage (**deltaValue**), depending on the mode (**EM**). The actuator will be charged with this calculated value. EncIncr will be clear the encoder and the procedure starts again.

The values of the encoder can be analyzed by 3 different modes (**EM**):

- Normal with acceleration (**EM0**)

$$\text{Calculation deltaValue: } \text{deltaValue} = \text{EncIncr}^{\text{EncExponent}}$$

- Adjustable interval (**EM1**)

$$\text{Calculation deltaValue: } \text{deltaValue} = \text{EncStep}$$

- Adjustable interval with acceleration (**EM2**)

$$\text{Calculation deltaValue: } \text{deltaValue} = \text{EncIncr} * \text{EncStep}$$

6.6.5 Encoder Commands Generally

Syntax encmode,<0..2>

Return None.

Example encmode,1

The mode of encoders is set to EM1 (adjustable interval).

Syntax entime,<0..255>

Return None.

Example entime,2

Scanning interval (SI) is set to 0.04 sec.

Scanning interval (**SI**) can be adjusted in a range between 0..5.1 sec with a step size of 0.02 sec. The evaluation of the encoder will be done in this time period. **In each interval only one encoder can be evaluated!** This means, if you have 3 active channels and an adjusted interval of 1 sec. the encoder will be scanned in a interval of 3 seconds.

Syntax enclim,<1..65535>

Return None.

Example enclim,10000

The step- limitation is set to 10000.

If the absolut value of **deltaValue** is higher than enclim, **deltaValue** will set to enclim with the same prefix.

The above-named comands are valid for all modes.

6.6.6 Special Commands for Encoder

- Normal with acceleration (*EM0*)

Syntax encexp,<1..10>

Return None.

Example encexp,3
The exponent is set to 3.

- Adjustable interval with and without acceleration (*EM1,2*)

Syntax encstol,<0.001..150.000>

Return None.

Example encstol,1.000
The step size for “open loop” is set to 1 V.

The numerical resolution of 1mV will be not achieved due to the resolution of the DA-converter of 16 bit. The real step size is approximately 3 mV

Syntax encstcl,<0.001..100.000> 

Return None.

Example encstcl,3
The exponent is set to 3.

7.0 Technical Data

	NPC3	NPC3SG
Number of channels	3	
Output power	3 x 5W	
Output voltage	-20V to +130V	
Output current (continuous)	3 x 40mA	
Noise of output voltage	<0,3mV _{RMS} @ 500 Hz	
Modulation input (MOD)	0 V to +10 V, Sub-D25	
Input impedance	10 kΩ	
Manually control	digital encoder	
Display	TFT full colour graphic display, 320 x 240 Pixel	
Output connector	3 x Sub-D15	
Monitor voltage (MON) NPC3SG only selectable by command <i>monwpa</i>	Sub-D25, output impedance <100Ω -13 to +13 V measuring system voltage (open loop) 0 to +10 V measuring system voltage (closed loop)	
Monitor voltage (MON)	Sub-D25, output impedance <100 Ω 0 to +10 V (equates to actuator voltage -20 to +130 V)	
Closed loop control (👉) NPC3SG only	PID analogue, switched on/off by pushing the encoder knob, for SG sensors	
Dimensions w x h x l	210 mm x 88 mm x 240 mm	
Mass	2.1 kg	
Interface	RS232 Sub-D9, USB 1.1	
Converter digitalization	16 bit	
Features	Soft start function, ASI function, over voltage protection, over temperature protection, short circuit proof, display with variable brightness	
Main power supply	24 VDC/2,5 A (wide range power supply 100–240 VAC is included in the shipment)	

8.0 Pinouts

8.1 Sub-D15 Male Output Connectors for Actuators

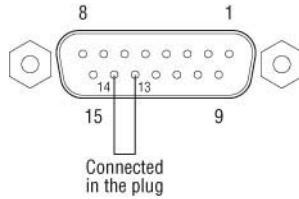

Pin #	Description
1	Measurement ground
2	Analog ground
3	+15 V ⁽¹⁾
4	Ground
5	SDA for ID-chip
6	+5 V ⁽¹⁾
7	Not connected
8	Piezovoltage
9	Measurement input
10	-15 V ⁽¹⁾
11	Analog ground
12	SCL for ID-chip
13	Detection if actuator is plugged
14	Ground
15	Piezoground

¹⁾ Note for external use.

8.2 Sub-D25 Femal Connector for Modulation/Monitor

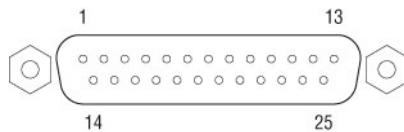

Pin #	Description
1	Modulation channel #1
2	Monitor channel #1
3	MOD-MON difference channel #1
4	Not connected
5	Modulation channel #2
6	Monitor channel #2
7	MOD-MON difference channel #2
8	Not connected
9	Modulation channel #3
10	Monitor channel #3
11	MOD-MON difference channel #3
12	Not connected
13	Not connected
14	Ground
15	Ground
16	Ground
17	Not connected
18	Ground
19	Ground
20	Ground
21	Not connected
22	Ground
23	Ground
24	Ground
25	Not connected

8.3 Sub-D9 Femal Connector for RS-232

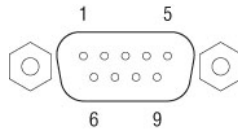

Pin #	Description	Explanation
1		Not connected
2	TxD	RS-232 Transmitter
3	RxD	RS-232 Receiver
4-6		Bridge
5	GND	RS-232 Ground
7-8		Bridge
9		Not connected

8.4 USB1.1 Connector

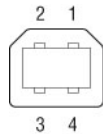

Pin #	Description	Explanation
1	VCC	+5 V Voltage supply
2	D-	- Data
3	D+	+ Data
4	GND	Main power supply ground

8.5 Main Supply Voltage Connector

NPC3 and NPC3SG need 24 VDC and require at least a current of 2.5 A. The 2.1 mm power plug of the NPC3 and NPC3SG controller has the following layout:

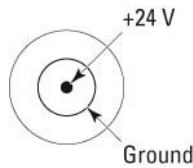

Pin #	Description
Center	24 VDC
Outer	Ground

9.0 Troubleshooting

NPC3 and NPC3SG recognizes possible failure causes, e.g. out of control range or over temperature. kommen, wie z.B. Reglerüberlauf oder Temperaturüberschreitung. Both devices sends in this case an error to the host. This error code has the structure: *ERROR,FWch0,FWch1,FWch2* . Specific errors are hexadecimal-coded as described in the table below.

Bit	Description
0	Actuator not connected
1	Short cut in the actuator
12	Controller underflow
13	Controller overflow
14	Wrong actuator
15	Over temperature
2,3,4,5,6,7,8,9,10,11	Reserve

Frequently error states and the handling for trouble shooting are described in table below.

Error	Troubleshooting
No response after power-on	Check that the power line is correct connected and the line switch is on. Check the wall power supply (green LED is on?).
Not connected is visible for one or more channels „	Check the correct connection between actuator and amplifier. Check the interface line (cables are not harmed?).
UDL or OVL flashes in closed-loop mode (CL)	Controller overflow, maybe actuator and/or load are blocked or the actual load deviated from the original calibration. Please contact our service if you are not shure what is to do!
Actuator is not stable in closed-loop (e.g. oscillations)	Maybe load is different from the load in the original calibration, please check the load. Please contact our service if you are not shure what is to do!



Newport®

Experience | Solutions

Visit Newport Online at:
www.newport.com

North America & Asia

Newport Corporation
1791 Deere Ave.
Irvine, CA 92606, USA

Sales

Tel.: (800) 222-6440
e-mail: sales@newport.com

Technical Support

Tel.: (800) 222-6440
e-mail: tech@newport.com

Service, RMAs & Returns

Tel.: (800) 222-6440
e-mail: rma.service@newport.com

Europe

MICRO-CONTROLE Spectra-Physics S.A.S
1, rue Jules Guesde – Bât. B
ZI Bois de l'Épine – BP189
91006 Evry Cedex
France

Sales

Tel.: +33 (0)1.60.91.68.68
e-mail: france@newport-fr.com

Technical Support

e-mail: tech_europe@newport.com

Service & Returns

Tel.: +33 (0)2.38.40.51.55