

VICTOR 81A/81B

Digital Multimeter Operation Manual

一.General	1
二.Open-Package Inspection.....	1
三.Safety Note	2
四.Front Panel& Button Function Description	4
五.Other Functions.....	5
六.Property.....	5
七.Instrument Maintenance.....	15
八.Fault Elimination.....	16

一、General

VICTOR 81A/B is a steady performance, high security 3 1/2 digital multimeter. It uses LCD with 18.9mm high figure to make the reading clear.

The digital multimeter has the function of measuring ACV, DCV, ACA, DCA, Resistance, Celsius & Fahrenheit Temperature, Diode, Continuity. The instrument also has the features of Unit Symbol Display, Auto/Manual Range Selection, Auto Power Offer and Alarm Function. It adopts the directly driven 8 digits microprocessor and dual-integral A/D converter, which provide the high resolution, high accuracy displaying driver. Because of its outstanding functions, the instrument is an excellent tool and most suitable for lab, factory, maintenance and repair users.

二、Open-Package Inspection

Open the gift box and take out the instrument, carefully check the following accessories. If any accessory is missed or damaged, please contact the manufactory at once.

- Digital Multimeter 1PC
- Operation Manual 1PC
- Test Leads 1SET
- Temperature Probe(K Type Thermocouple)
(Only VICTOR81B) 1PC
- AAA (1.5V) 7# Battery 2PCS
- Holster 1PC

三、Safety Note











The instrument is designed according to IEC1010 standard (safety standard issued by International Electro technical Committee). Please read the following before operation.

1. Caution to avoid the electric shock when measuring voltage higher than 36V DC, 25AC, current higher than 10mA, AC power line with inductance load and AC power line during the power fluctuation.
2. Before measuring, should check if the function knob is set in the correct range and make sure the test leads connect reliably, link up correctly, and insulate properly to avoid the electric shock
3. It meets the requirements of the safety standard only to use the instrument with the equipped test leads. If the test leads are broken, should replace them by the same type and same electric specification test leads.
4. Do not replace the inside fuse by the unconfirmed one. Only replace it by the same type and specification fuse. Before replacement, should keep the test leads off the tested point to make sure there is no any signal at the input terminal.
5. Do not replace the inside batteries by the unconfirmed one. Only replace them by the same type and specification batteries. Before replacement, should keep the test leads off the tested point to make sure there is no any signal at the input terminal.
6. When measuring electricity, do not connect the body with the ground directly, and do not touch the possible exposed metallic terminal,

output socket or lead clamp with ground potential. Usually use the dry cloth, rubber overshoes, rubber cushion and other insulated materials to keep the body isolated with the ground.

7. Do not store and use the instrument in high humidity, high temperature, combustible, explosive and strong magnetic places.
8. It is possible to damage the instrument and endanger the safety of the users when measuring the voltage over the limit. The allowed maximum voltage is printed on the front panel of the instrument, do not measure the value over the standard safety voltage, do not input the range limit specified to void the electric shock and instrument damage.
9. Do not measure any voltage when connecting the test leads with the current terminal to avoid damaging the instrument and endangering the safety of the users.
10. Do not try to calibrate or repair the instrument, should operate it by the specially trained or qualified professional people.
11. The function/range selection knob should be set in the correct range when measuring. When switching the function/range selection knob, keep the test leads off the tested object to make sure there is no any signal at the input terminal. Do not switch the function/range selection knob when measuring.
12. When LCD displays “”, please replace the batteries in time to make sure the measuring accuracy.
13. Do not allow to measure the voltage when connecting the test leads with the current terminal!

14. Do not try to modify the inner circuit at will to avoid damaging the instrument and endangering the safety of the users.
15. Safety Symbol Description:

	Warning!		DCA
	High Voltage! Dangerous!		ACA
	GND		DCA & ACA
	Dual Insulation		Meets the direction of European IEC
	Low Battery		Fuse

四、Front Panel & Button Function Description

1. Instrument Model Number
2. LCD Display: Display the measured data and unit.
3. Function Button
 - 3.1. MAX (Max Value Hold) : Press the button, the reading is renewed and the max value is held on LCD.
 - 3.2. SELECT (Function Switch): Press the button, DC/AC mode,  , °C/°F performance switch.
 - 3.3. HOLD (Data Hold) : Press the button, the reading is locked, press the button again, the lock is cleared.
 - 3.4. RANGE (Auto/Manual Range Switch) : Auto Range is the original states, press the button to switch to the Manual Range. At the Manual

Range mode, press the button once, the range is switched to the higher one, press the button again to switch the range to the lowest one when measuring the highest range, the cycle is in proper order from low to high. Keep pressing the button for 2 sec., return to Auto Range mode.

4. Knob Switch: Change the measuring

function and range.

5. Input Terminals

5.1. Current, Voltage, Diode, Resistance, Buzzer,

Temperature “-” Input terminal.

Temperature “+” Input terminal.

5.2. 10A “+” input terminal.

5.3. Voltage, Diode, Resistance, Buzzer, Temperature and Current

less than 200mA “+” input terminal.

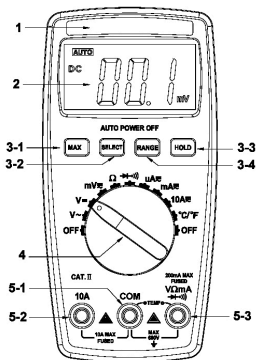

五、 Other Functions

Stop working for 15 seconds during measurement, the instrument will be auto power off (sleeping mode) to save the power; in the auto power offer mode, press any function button or change the knob switch, the instrument will get into the auto power on mode (working mode); the auto power offer mode will be cancelled by pressing the HOLD button to turn on the instrument.

六、 Property

1. General Property

1-1. Display: LCD

1-2. Max Display: 1999 (3 1/2) counts automatic polarity display and unit display

- 1-3. Measuring Method: Dual integral A/D converter
- 1-4. Sampling Rate: Approx. 3 times / sec.
- 1-5. Over range Indication: Display“OL”
- 1-6. Low Battery Indication: “”symbol appearance;
- 1-7. Operation Environment: (0~40) °C, Relative Humidity: <80% ;
- 1-8. Storage Environment: (0~50) °C, Relative Humidity: <80% ;
- 1-9. Power: 2pcs 1.5V batteries (“AAA”7# battery);
- 1-10. Dimension (size): 145×74×36mm
- 1-11. Weight: Approx. 185g (Including 2pcs 1.5Vbatteries)
- 1-12. Accessories: 1pc operation manual, Holster, 1pc gift box, 1 set 10A test leads、1pc K Type Temperature Probe TP01 (only VICTOR81B) and 2pcs 1.5 batteries。

2. Technical Property

2-1.Accuracy:±(%×reading+ digits), at (23±5)°C, relative humidity <75%.

One year calibration guarantee since the time dispatched from the factory.。

2-2.Performance (note“▲”indicates the instrument has the function)

Function	Model	VICTOR81A	VICTOR81B
DCV		▲	▲
ACV		▲	▲
DCA		▲	▲
ACA		▲	▲
Ω		▲	▲
Diode/Continuity		▲	▲
Celsius/Fahrenheit °C/°F		*	▲

2-3. Technic Specification (note “*” indicates the instrument does not have the range)

2-3-1. DCV

1. Insert the red and black test leads separately to  and COM input terminals.
2. Turn the knob switch to $mV_{\overline{=}}$ Range, press “SELECT” button to switch to DCV measurement mode.
3. This range is 200mV, The reading to measure the voltage less than 200mV is much accurate and stable than the reading measured in the Range “ $V_{\overline{=}}$ ”.
4. Turn the knob switch to “ $V_{\overline{=}}$ ” Range.
5. Auto range mode is the original states, it displays “AUTO” symbol, Press “RANGE” button to switch to Manual range mode, can select 200mV, 2V、20V、200V、600V Range.
6. Connect the test leads to the tested point, the voltage and polarity of point connected by red lead will be displayed on LCD.

Note:

1. At the Manual Range mode, if “OL” is displayed on LCD, it indicates the tested voltage value has exceeded the present range limit, please select the higher range to complete the measurement.
2. Do not measure the voltage higher than 600V. Otherwise, there is the danger to damage the instrument.
3. When measuring the high voltage, caution to avoid the body touches the high voltage.

Range	Accuracy	VICTOR81A	VICTOR81B	Resolution
200mV		$\pm(0.5\%+4d)$		100uV
2V				1mV
20V				10mV
200V				100mA
600V		$\pm(1.0\%+4d)$		1V

Input Impedance: $>10M\Omega$ at Range 200mV , $40M\Omega$ at other Ranges.

Overload Protection: 600V AC or 600V AC Peak Value;

2-3-2. ACV

1. Insert the red and black test leads separately to  and COM input terminals.
2. Turn the knob switch to mV_{AC} Range, press “SELECT” button to switch to ACV measurement mode.
3. This range is 200mV, The reading to measure the voltage less than 200mV is much accurate and stable than the reading measured in the Range “ V_{AC} ”.
4. Turn the knob switch to “ V_{AC} ” Range.
5. Auto range mode is the original states, it displays “AUTO” symbol, Press “RANGE” button to switch to Manual range mode, can select 200mV、2V、20V、200V、600V Range.
6. Connect the test leads to the tested point, the voltage and polarity of point connected by red lead will be displayed on LCD.

Note:

1. At the Manual Range mode, if “OL” is displayed on LCD, it indicates the

tested voltage value has exceeded the present range limit, please select the higher range to complete the measurement.

- Do not measure the voltage higher than 600V. Otherwise, there is the danger to damage the instrument.
- When measuring the high voltage, caution to avoid the body touches the high voltage.

Range	Accuracy	VICTOR81A	VICTOR81B	Resolution
200mV		$\pm(1.5\%+20d)$		100uV
2V		$\pm(0.8\%+6d)$		1mV
20V				10mV
200V				100mV
600V		$\pm(1.0\%+6d)$		1V

Input Impedance: $>10M\Omega$ at Range 200mV, $40M\Omega$ at other ranges.

Overload Protection: 600V DC or 600V AC Peak Value;

Frequency Response: (50~200) Hz

Display: Average value response (RMS of sine wave).

2-3-3. DCA

- Insert the black test lead to the COM input terminal, and red test lead to  input terminal (max 200 mV) or 10A input terminal (max 10A).
- Turn the knob switch to Current Range, press “SELECT” button to switch to DCA measurement mode. Connect the test leads to the tested point in series, the current value and polarity of point connected by red lead will be displayed on LCD simultaneously.
- Press “RANGE” button to select auto or manual range mode.

Note:

1. Firstly users should select the auto range mode, if users had no idea about the range of tested current, and then select the proper range based on displaying value.
2. If “OL” is displayed on LCD, it indicates the tested current value has exceeded the present range limit, please select the higher range to complete the measurement.
3. Max input value is 200mA or 10A (Depending on the terminal the red test lead is inserted) .

The input value is exceeding the range limit, the fuse will be melt, even damage the instrument.

Accuracy Range	VICTOR81A	VICTOR81B	Resolution
200uA	$\pm(1.0\%+10d)$		0.1uA
2000uA			1uA
20mA			10uA
200mA			100uA
10A	$\pm(1.2\%+10d)$		10mA

Max measurement voltage drop: Full Range mA is 1.2V, A is 100mV;

Max input current: 10A (less than 15 seconds);

Overload Protection: 0.2A/250V restorable fuse, 10A/250V fuse.

2-3-4. ACA

1. Insert the black test lead to the COM input terminal, and red test lead to  input terminal (max 200 mV) or 10A input terminal (max 10A).
2. Turn the knob switch to Current Range, press “SELECT” button to switch to

ACA measurement mode. Connect the test leads to the tested point in series, the current value and polarity of point connected by red lead will be displayed on LCD simultaneously.

3. Press “RANGE” button to select auto or manual range mode.

Note:

1. Firstly users should select the auto range mode, if users had no idea about the range of tested current, and then select the proper range based on displaying value.
2. If “OL” is displayed on LCD, it indicates the tested current value has exceeded the present range limit, please select the higher range to complete the measurement.
3. Max input value is 200mA or 10A (Depending on the terminal the red test lead is inserted) .

The input value is exceeding the range limit, the fuse will be melt, even damage the instrument.

Accuracy Range	VICTOR81A	VICTOR81B	Resolution
200uA	$\pm(1.5\%+10d)$		0.1uA
2000uA			1uA
20mA			10uA
200mA			100uA
10A	$\pm(2.5\%+15d)$		10mA

Max measurement voltage drop: Full Range mA is 1.2V, A is 100mV;

Max input current: 10A (less than 15 seconds);

Overload Protection: 0.2A/250V restorable fuse, 10A/250V fuse.

Frequency Response: 10A Range (50~200)Hz,

2-3-5.Resistance (Ω)

1. Insert the red and black test leads separately to  and COM input terminals.
2. Turn the knob switch to “ Ω ” Range, connect the test leads cross with the tested resistor.
3. Press “RANGE” button to select auto or manual range mode.
4. When measuring the min. resistance , please short-circuit the test leads at first to test the wire resistance, and then deduct it from the actual resistance.

Note:

1. Firstly users should select the auto range mode, if users had no idea about the range of tested current, and then select the proper range based on displaying value.
2. If “OL” is displayed on LCD, it indicates the tested resistance value has exceeded the present range limit, please select the higher range to complete the measurement. When measuring the Resistor higher than $1M\Omega$, the instrument will take several seconds to make the reading stable, it is normal when measuring the high resistor.
3. When the input terminal is open circuit, it will display “OL”.
4. When measuring in line resistor, be sure that the power is off and all capacitors are released completely.



Accuracy Range	VICTOR81 A	VICTOR81 B	Resolution
200Ω	±(0.8%+5d)		0.1Ω
2kΩ	±(0.8%+4d)		1Ω
20kΩ			10Ω
200kΩ			100Ω
2MΩ			1kΩ
20MΩ	±(1.2%+10d)		10kΩ

Open Voltage circuit: Less than 200mV;

Overload Protection: 250V DC or AC Peak Value;

Note: When measuring at Range 200Ω, please short-circuit the test leads at first to test the wire resistance, and then deduct it from the actual resistance.

2-3-6. Diode and Continuity Test

1. Insert the black test lead to “COM” terminal and the red test lead to “” terminal (the polarity of red lead is “+”)
2. Turn the knob to  range ,press “SELECT” button to select the Diode measurement mode.
3. Forward Measurement: connect test leads with the diode under tested, the red test lead connect to diode positive polarity, the black test lead to diode cathode polarity, the reading is the approx. value of diode forward volt drop.
4. Backward Measurement: the red test connect to diode positive polarity, the black test lead to diode cathode polarity ,the LCD displays “OL”.
5. The complete diode testing includes forward and backward measurement, if the result isn't meet the above, it means the diode is bad.

- Press “SELECT” button to select the Continuity measurement mode.
- Insert test leads to two points of tested circuit, if the inner buzzer sounds, the resistance is less than 50Ω .

Range	Display	Test Condition
	Forward Voltage Drop of Diode	Forward DC Current is Approx. 0.5mA , Backward Voltage is Approx. 1.5V
	Buzzer makes a long sound while resistance is less than 50Ω	Open circuit voltage is Approx. 0.5V

Overload Protection: 250V DC or AC Peak Value.

CAUTION: DO NOT INPUT VOLTAGE AT THIS RANGE!

2-3-7.Celsius/Fahrenheit($^{\circ}\text{C}/^{\circ}\text{F}$)(Only VICTOR81B)

- Switch the knob to “ $^{\circ}\text{C}/^{\circ}\text{F}$ ” range, press “SELECT” button to switch to “ $^{\circ}\text{C}$ ” and “ $^{\circ}\text{F}$ ” measurement mode.
- Insert the cathode(black pin) of cold end (free end) of thermocouple into “COM” jack, anode (red pin) into “ $\overset{\text{V}\Omega\text{mA}}{\rightarrow|-\circ|}$ ” terminal, put the working end (temperature measurement end) of thermocouple on the surface or inside the object to be tested. Then you can read temperature from the screen, and the data is in Centigrade.

Note:

- When the input terminal open-circuit ,it will display the normal temperature.
- Don’t change the temperature probe optionally ,or the value accuracy isn’t guarantee.
- Don’t input voltage at temperature range.

Accuracy Range	Accuracy	Resolution
(-20~1000)°C	<400°C±(1.0%+5d) ≥400°C±(1.5%+15d)	1°C
(0~1832) °F	±(1.5%+15d)	1°F

Sensor: K Type Thermocouple (banana plug)。

CAUTION: DO NOT INPUT VOLTAGE AT THIS RANGE!

七、Instrument Maintenance

Instrument is a high accuracy instrument, please don't modify the circuit.

1. Keep the instrument away from water, dust and shock.
2. Do not store and operate the meter under the condition of high temperature, high humidity, combustible, explosive and strong magnetic place.
3. Wipe the case with a damp cloth and detergent, do not use abrasives and alcohol.
4. If do not operate for a long time, should take out the battery to avoid leakage.
5. When  symbol displays, should replace the battery following the steps:
 - 5-1. Unlock the screw and remove the battery case;
 - 5-2. Take out the old battery and replace the new one. It's better to use alkaline battery for longer life.
 - 5-3. Fit on the battery case and lock the screw.

Note:

1. Don't input the voltage value higher than DC 1000V or AC Peak Value.

2. Don't measuring the voltage at current, resistance, diode and continuity range.
3. Don't use the instrument when the battery isn't installed or the back case isn't firm.
4. When replacing battery or fuse, please take away the test leads from the measured point and power off at first.

八、 Fault Elimination

If the instrument does not work properly, check the instrument as following:

Fault	Solution
No Display	<ul style="list-style-type: none"> ● Turn on power; ● Replace battery.
 symbol appearance	<ul style="list-style-type: none"> ● Replace battery.
Big error value	<ul style="list-style-type: none"> ● Replace battery.

The specifications are subject to change without notice.

The content of this manual is regarded as correct, error or omits Pls. contact with factory.

We hereby will not be responsible for the accident and damage caused by improper operation .

The function stated for this operation manual cannot be the reason of special usage.