



User Instruction Manual
Lanyards With Integral Energy Absorbers and
Energy Absorber Components Used in
Personal Fall Arrest Systems (ANSI Z359.1 and
ANSI A10.14 "Type I" System)

This manual is intended to meet the Manufacturer's Instructions as required by ANSI A10.14, and should be used as part of an employee training program as required by OSHA.



Figure 1 - EZ STOP® Lanyards

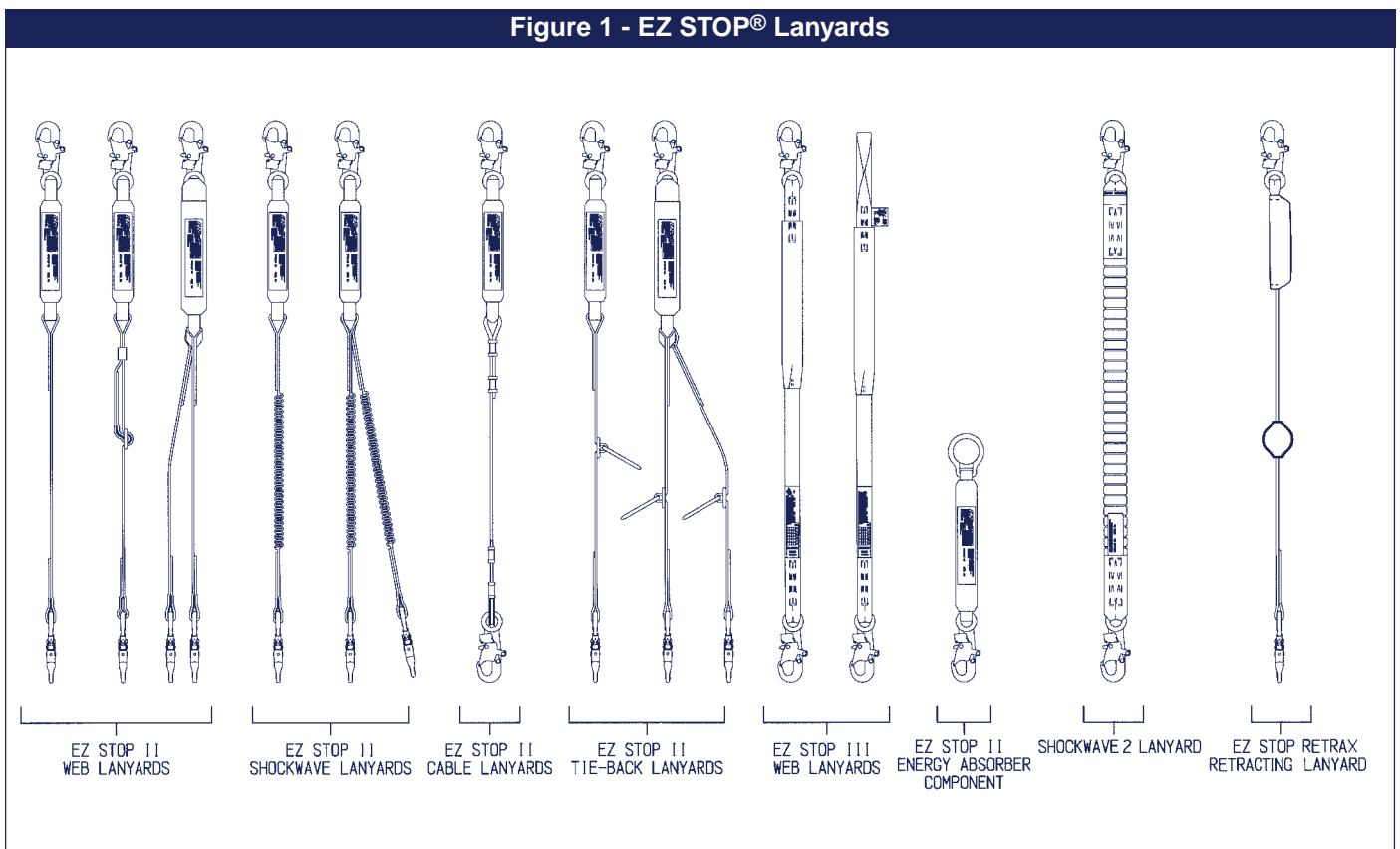

WARNING: This product is part of a personal restraint, work positioning, suspension, or rescue system. The user must read and follow the manufacturer's instructions for each component or part of the complete system. These instructions must be provided to the user of this equipment. The user must read and understand these instructions or have them explained to them before using this equipment. Manufacturer's instructions must be followed for proper use and maintenance of this product. Alterations or misuse of this product or failure to follow instructions may result in serious injury or death.

IMPORTANT: If you have any questions on the use, care, application, or suitability for use of this equipment, contact DBI/SALA.

IMPORTANT: Before using this equipment record the product identification information (found on the I.D. label) in the inspection and maintenance log in section 9.0 of this manual.

DESCRIPTIONS

EZ STOP® II WEB LANYARDS

- 1-in. web, 9503175 hook each end.
- 1-in. web, 9503175 hook one end, 2007153 hook other end.
- 1-in. web, 9503175 hook one end, 1200049 wire pipe clamp other end.
- 1-in. web, 9503175 hook one end, 2000108 carabiner other end.
- 1-in. web, web loop one end, 2007153 hook other end.
- 1-in. web, web loop one end, 9503175 hook other end.
- 1-in. web, adjustable, 9503175 hook each end.
- 1-in. web, 100% tie-off, 9503175 hook center, 2007153 hook leg ends.
- 1-in. web, 100% tie-off, 9503175 hook center and leg ends.
- 1-in. web, 100% tie-off, 9503175 hook center, 2000108 carabiner leg ends.
- 1-in. web, 100% tie-off, web loop center, 2007153 hook leg ends.
- 1-in. web, 100% tie-off, web loop center, 9503175 hook leg ends.

EZ STOP® II SHOCKWAVE™ WEB LANYARDS

- 1-in. elastic web, 9503175 hook each end.
- 1-in. elastic web, 9503175 hook one end, 2007153 hook other end.
- 1-in. elastic web, web loop one end, 2007153 hook other end.
- 1-in. elastic web, web loop one end, 9503175 hook other end.
- 1-in. elastic web, 100% tie-off, 9503175 hook center and both ends.
- 1-in. elastic web, 100% tie-off, 9503175 hook center, 2007153 hook leg ends.
- 1-in. elastic web, 100% tie-off, web loop center, 2007153 hook leg ends.
- 1-in. elastic web, 100% tie-off, web loop center, 9503175 hook leg ends.

EZ STOP® II CABLE LANYARDS

- 7/32-in. cable, 9503175 snap hook each end.
- 7/32-in. cable, 9503175 snap hook one end, 2007153 snap hook other end.
- 7/32-in. cable, 9503175 snap hook one end, 2000108 carabiner other end.

EZ STOP® II TIE-BACK LANYARDS

- 1-in. web, 9503175 hook both ends, floating D-ring.
- 1-in. web, 100% tie-off, 9503175 hook center and leg ends, floating D-rings.

EZ STOP® III WEB LANYARDS

- 1 3/8-in. web, 9503175 hook each end.
- 1 3/8-in. web, 9503175 hook one end, 2007153 hook one end.
- 1 3/8-in. web, 9503175 hook one end, 2000108 carabiner one end.
- 1 3/8-in. web, 9503175 hook one end, 1200049 wire pipe hook one end.
- 1 3/8-in. web, web loop one end, 2007153 hook one end.
- 1 3/8-in. web, web loop one end, 9503175 hook one end.

EZ STOP® II ENERGY ABSORBER COMPONENT

- 9503175 hook one end, D-ring one end, 24-in. length.

SHOCKWAVE 2™ WEB LANYARD

- 1 15/16-in. web, 9503175 hook each end.

EZ STOP® RETRAX™ RETRACTING WEB LANYARD

- 1 3/8-in. web, 9503175 hook each end.
- 1 3/8-in. web, 9503175 hook one end, 9510057 hook other end.
- 1 3/8-in. web, 9503175 hook one end, 2007153 hook other end.
- 1 3/8-in. web, 100% tie-off, 9503175 hook each end.

Note: Other hook and lanyard options available.

1.0 APPLICATIONS

- 1.1 **PURPOSE:** DBI/SALA Energy Absorbing Lanyards and Energy Absorbers are intended to be used as part of a personal fall arrest system. Applications for these products include inspection work, construction and demolition, maintenance, oil production, confined space rescue, and similar activities where there exists the possibility of a fall. This equipment is specially designed to dissipate fall energy and limit fall arrest forces transferred to the body.
- 1.2 The following application limitations must be considered before using this product:
- A. **CAPACITY:** This equipment is for use by persons with a combined weight (person, clothing, tools, etc.) of no more than 310 lbs.
 - B. **PHYSICAL AND ENVIRONMENTAL HAZARDS:** Use of this equipment in areas containing physical or environmental hazards may require that additional precautions be taken to reduce the possibility of damage to this equipment or injury to the user. Hazards may include, but are not limited to: high heat, strong or caustic chemicals, corrosive environments, the possibility of electric current flowing through this equipment when working near high voltage power lines, explosive or toxic gases, moving machinery, or sharp edges. Contact DBI/SALA if you have any questions about the application of this equipment in areas where physical or environmental hazards are present.
 - C. **TRAINING:** This equipment is intended to be installed and used by persons who have been properly trained in its correct application and use.
- 1.3 Refer to national consensus (including ANSI Z359.1 and ANSI A10.14), applicable local, state, and federal (OSHA) requirements governing this equipment for more information on Energy Absorbing Lanyards, Energy Absorbers and associated system components.

2.0 SYSTEM REQUIREMENTS

- 2.1 **COMPATIBILITY OF CONNECTORS:** DBI/SALA equipment is designed for use with DBI/SALA approved components and subsystems only. Substitutions or replacements made with non-approved components or subsystems may jeopardize compatibility of equipment and may effect the safety and reliability of the complete system.

COMPATIBILITY: Connectors are considered to be compatible with connecting elements when they have been designed to work together in such a way that their sizes and shapes do not cause their gate mechanisms to inadvertently open regardless of how they become oriented. Contact DBI/SALA if you have any questions about compatibility.

Figure 2 - Unintentional Disengagement (Roll-out)

If the connecting element that a snap hook (shown) or carabiner attaches to is undersized or irregular in shape, a situation could occur where the connecting element applies a force to the gate of the snap hook or carabiner. This force may cause the gate (of either a self-locking or a non-locking snap hook) to open, allowing the snap hook or carabiner to disengage from the connecting point.

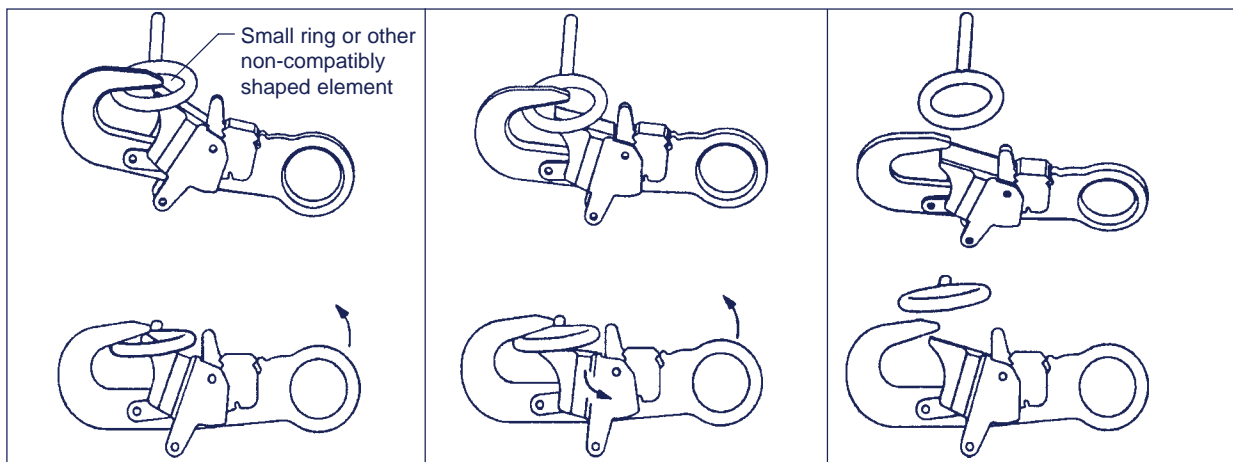

1. Force is applied to the snap hook.

2. The gate presses against the connecting ring.

3. The gate opens allowing the snap hook to slip off.

Connectors (hooks, carabiners, and D-rings) must be capable of supporting at least 5,000 lbs. (22kN). Connectors must be compatible with the anchorage or other system components. Do not use equipment that is not compatible. Non-compatible connectors may unintentionally disengage. See Figure 2. Connectors must be compatible in size, shape, and strength. Self locking snap hooks and carabiners are required by ANSI Z359.1 and OSHA.

2.2 Making Connections: Only use self locking snap hooks and carabiners with this equipment. Only use connectors that are suitable to each application. Ensure all connections are compatible in size, shape and strength. Do not use equipment that is not compatible. Ensure all connectors are fully closed and locked.

DBI/SALA connectors (snap hooks and carabiners) are designed to be used only as specified in each product's user's instructions. See Figure 3 for inappropriate connections. DBI/SALA snap hooks and carabiners should not be connected:

- A. To a D-ring to which another connector is attached.
- B. In a manner that would result in a load on the gate.

NOTE: Large throat opening snap hooks should not be connected to standard size D-rings or similar objects which will result in a load on the gate if the hook or D-ring twists or rotates. Large throat snap hooks are designed for use on fixed structural elements such as rebar or cross members that are not shaped in a way that can capture the gate of the hook.

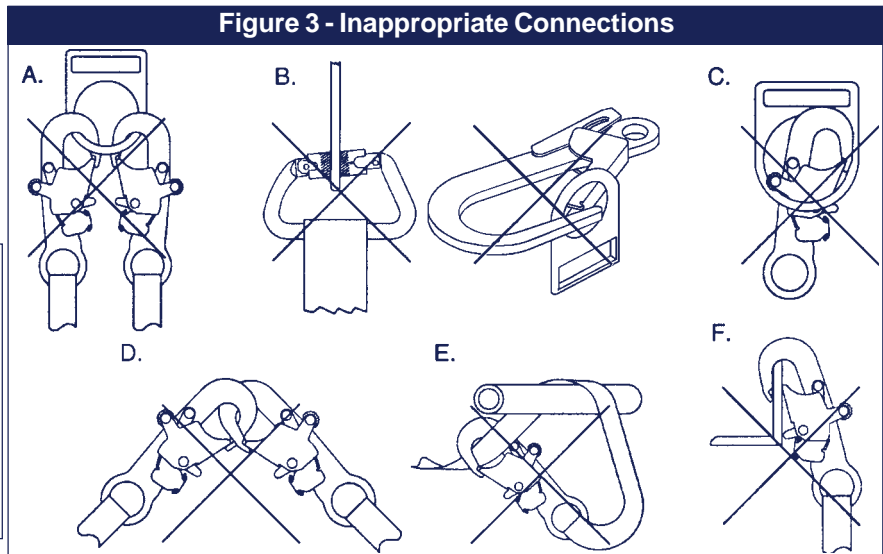

- C. In a false engagement, where features that protrude from the snap hook or carabiner catch on the anchor and without visual confirmation seems to be fully engaged to the anchor point.
- D. To each other.
- E. Directly to webbing or rope lanyard or tie-back (unless the manufacturer's instructions for both the lanyard and connector specifically allows such a connection).
- F. To any object which is shaped or dimensioned such that the snap hook or carabiners will not close and lock, or that roll-out could occur.

2.3 ANCHORAGE STRENGTH: Anchorages selected for personal fall arrest systems (PFAS) shall have a strength capable of sustaining static loads, applied in the directions permitted by the PFAS, of at least; (A) 3,600 lbs. when certification exists (reference ANSI Z359.1 for certification definition), or (B) 5,000 lbs. in the absence of certification. When more than one PFAS is attached to an anchorage, the anchorage strengths set forth in (A) and (B) above must be multiplied by the number of PFAS attached to the anchorage. Per OSHA 1926.500 and 1910.66 - Anchorages used for attachment of PFAS shall be independent of any anchorage being used to support or suspend platforms, and capable of supporting at least 5,000 lbs. per user attached, or be designed, installed, and used as part of a complete PFAS which maintains a safety factor of at least two, and is supervised by a qualified person.

3.0 OPERATION AND USE

WARNING: Do not alter or intentionally misuse this equipment. Consult DBI/SALA when using this equipment in combination with components or subsystems other than those described in this manual. Some subsystem and component combinations may interfere with the operation of this equipment. Use caution when using this equipment around moving machinery, electrical hazards, chemical hazards, and sharp edges.

WARNING: Consult your doctor if there is reason to doubt your fitness to safely absorb the shock from a fall arrest. Age and fitness seriously affect a worker's ability to withstand falls. Pregnant women or minors must not use DBI/SALA energy absorbing lanyards.

- 3.1 BEFORE EACH USE** of this equipment, carefully inspect it to assure that it is in good working condition. Check for worn or damaged parts. Ensure all hardware is present and secure, and is not distorted or have any sharp edges, burrs, cracks, or corrosion. Ensure self locking snap hooks or carabiners work properly. Inspect rope or webbing for wear, cuts, burns, frayed edges, breaks, or other damage. See section 5.0 for further inspection details. Do not use if inspection reveals an unsafe condition.
- 3.2 PLAN** your fall protection system before starting your work. Take into consideration factors that affect your safety before, during, and after a fall. The following list gives some important points to consider when planning your system:
- A. ANCHORAGE:** Select a rigid anchorage point that is capable of supporting the required loads. See section 2.3. The anchorage location must be carefully selected to reduce possible free fall and swing fall hazards and to avoid striking an object during a fall. The anchorage should be generally level (horizontal) to prevent the anchorage connector from sliding down an incline when in use, which could cause serious injury to the user.
 - B. FREE FALL:** Personal fall arrest systems must be rigged such that the potential free fall is never greater than 6 feet (5 feet per ANSI A10.14). Avoid working above your anchorage level to avoid an increased free fall distance.

IMPORTANT: Some energy absorbing lanyards, such as EZ Stop® Retrax™ and the Shockwave lanyards, make use of retracting devices designed to shorten their free length. These devices do not decrease free fall distance

- C. FALL ARREST FORCES:** The assembled fall arrest system must keep fall arrest forces below 1,800 lbs. when used with a full body harness.
- D. FALL CLEARANCE:** Should a fall occur, there must be sufficient clearance in the fall area to arrest the fall before striking the ground or other object. Energy absorbers can extend the fall arrest distance by up to 42 inches. Figure 4 shows how to estimate fall clearance distance when using an energy absorbing lanyard or energy absorber subsystem. Other factors may influence the required clearance distances. For example, using an energy absorbing lanyard or energy absorber with a rope grab (fall arrestor) may require additional clearance due to stretch in the lifeline or sliding of the rope grab on the lifeline during fall arrest. Some full body harness models incorporate a sliding (positional) D-ring in the back as the fall arrest attachment, movement of this D-ring during fall arrest can increase the fall clearance distance required. Use caution when assembling system components that could act to extend the fall arrest distance (and therefore fall clearance required). Refer to manufacturer's instructions for each part of the system for more information on fall clearance.
- E. SWING FALLS:** Swing falls occur when the anchorage point is not directly above the point where a fall occurs. The force of striking an object while swinging (horizontal speed of the user due to the pendulum affect) can be great and may cause serious injury. In a swing fall situation, the total vertical fall distance of the user will be greater than if the user had fallen vertically directly below the anchorage point. The user must therefore account for an increase in the total free fall distance and the area needed to safely arrest the fall. Swing falls can be minimized by working as directly below the anchorage point as possible. Never permit

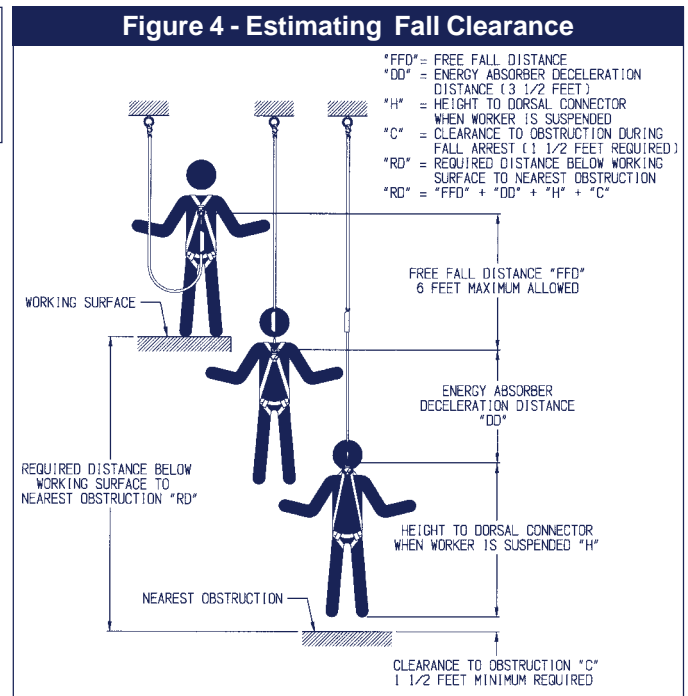

a swing fall if injury could occur. If a swing fall situation exists in your application contact DBI/SALA before proceeding. See Figure 5.

- F. **SHARP EDGES:** Avoid working where the lanyard, subsystem, or other system components will be in contact with, or abrade against, unprotected sharp edges. Do not loop lanyard around small diameter structural members. If working with this equipment near sharp edges is unavoidable, protection against cutting must be provided by using a heavy pad or other means over the exposed sharp edge.
- G. **RESCUE:** Should a fall occur, the user (employer) must have a rescue plan and the ability to implement it.
- H. **AFTER A FALL:** Lanyards with integral energy absorbers, or energy absorber components which have been subjected to the forces of arresting a fall must be removed from service and destroyed. See Figure 11.

WARNING: Read and follow manufacturer's instructions for associated equipment (full body harness, rope grab, etc.) used in your fall protection system.

IMPORTANT: For special (custom) versions of this product, follow the instructions herein. If included, see supplement for additional instructions.

3.3 MAKING CONNECTIONS: See Figure 6 for hook operation. When using a hook to connect to an anchorage, or when coupling components of the system together, ensure accidental disengagement (roll-out) cannot occur. Roll-out occurs when interference between a hook and the mating connector causes the hook's gate or keeper to accidentally open and release. Roll-out may occur when a hook is connected to an undersized ring such as an eye bolt or other non-compatible shaped connector. Self locking snap hooks or self locking and self closing gate carabiners should be used to reduce the possibility of roll-out when making connections. Do not use hooks or connectors that will not completely close over the attachment object. For these situations, use a tie-off adaptor or other anchorage connector to allow a compatible connection. Do not knot lanyard in any manner, and do not hook lanyard back into itself (choker style). Snap hooks and carabiners must not be connected to each other. Do not attach snap hooks to web loops.

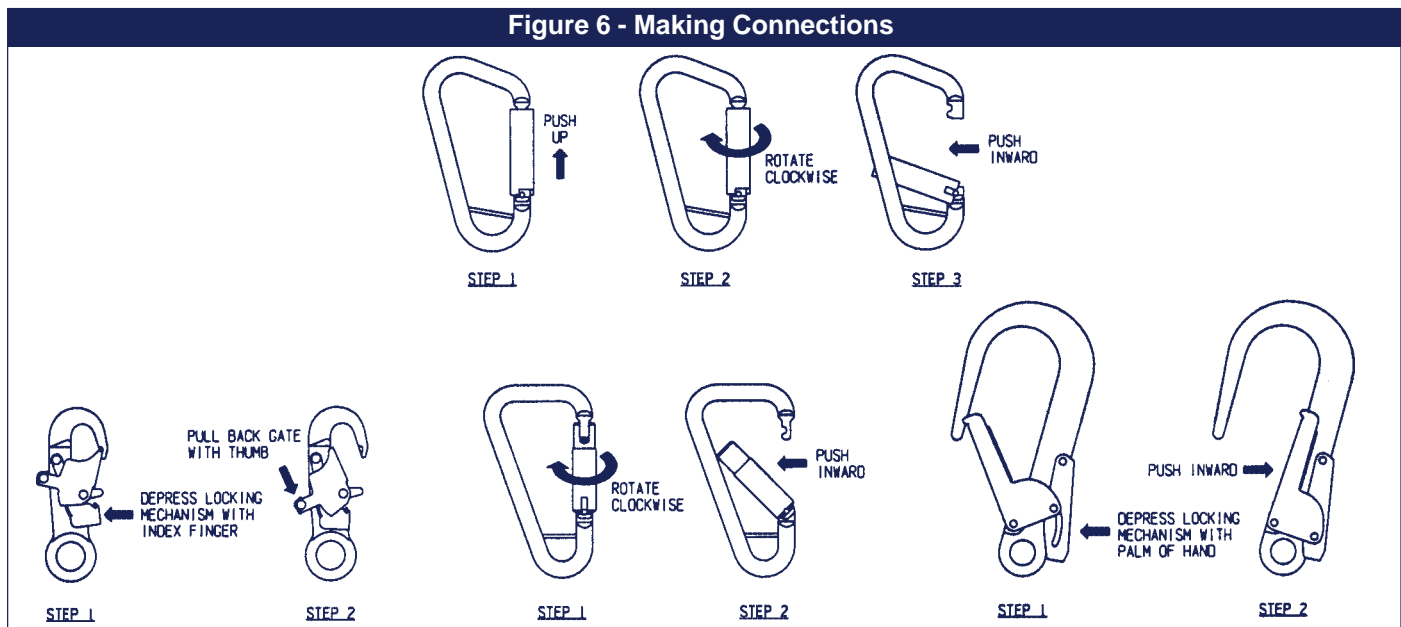

- A. **CONNECTING TO ANCHORAGE OR ANCHORAGE CONNECTOR:** See Figure 7. Always connect the energy absorber end of the lanyard to the body support (harness). Connect the lanyard end to the anchorage or anchorage connector. Component style energy absorbers should be connected to the body support first, then coupled to the rest of the system. Some anchorage connector devices may be supplied with permanently attached energy absorber. Use of an additional energy absorber or energy absorbing lanyard with these types of subsystems is not recommended. 100% tie-off "Y" type energy absorbing lanyards can be used to provide continuous fall protection while ascending, descending, or moving laterally. With one lanyard leg attached, the worker can move to a new location, attach unused lanyard leg, and disconnect attached leg. This procedure is repeated until new location is reached. With the EZ Stop® II Shockwave 100% tie-off type lanyard, only one leg of the lanyard shall be attached to the anchorage or anchorage connector once working location is reached.

Attaching a Tie-Back Lanyard: See Figure 8. Place the tie-back lanyard over the anchoring structure. Ensure the lanyard is not twisted. Adjust the floating D-ring so it hangs below the anchoring structure. Attach the lanyard end hook to the floating D-ring.

Attaching a Lanyard with Wire Form Pipe Hook: The wire form pipe hook is intended for use with pipes up to three inches in diameter. The anchorage must be geometrically compatible in size and shape. See Figure 9 for examples of proper and improper connections and intended load directions. Do not side load the pipe hook. Do not allow the pipe hook to contact electrical sources. Squeeze the handle to open the hook. Place hook around the anchorage and release handle. When connecting to an anchorage, ensure the hook fully closes and closure hooks engage eye loops on hook body.

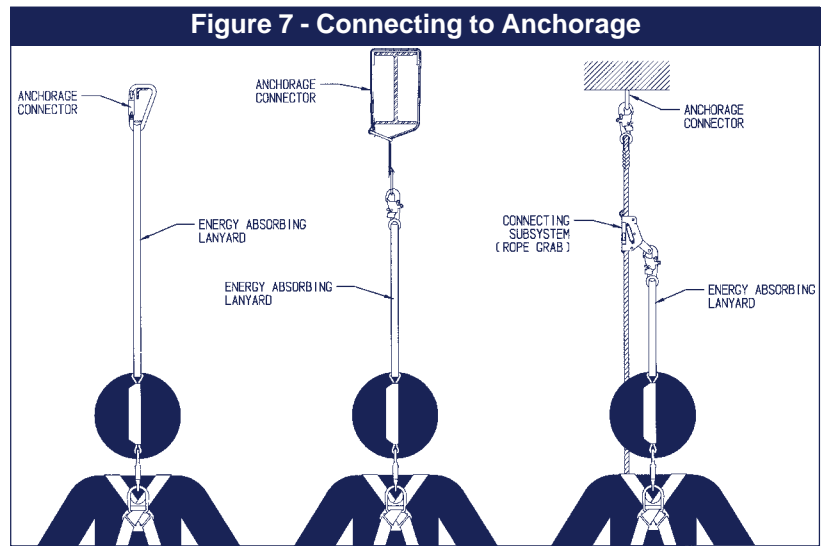

B. CONNECTING TO THE BODY SUPPORT: Connect the energy absorbing lanyard or energy absorber to the D-ring on the back between the shoulders (dorsal D-ring) on a full body harness. Connect so the energy absorber portion of the lanyard is on the body support side. DBI/SALA does not recommend using a body belt for fall arrest applications. If using a body belt, connect the energy absorbing lanyard or energy absorber to the D-ring and position the belt so the D-ring is located on the back side of the body.

Attaching a Lanyard with Web Loops: See Figure 10.

1. Insert the energy absorbing lanyard web loop through the harness web loop or D-ring.
2. Insert the opposite end of the energy absorbing lanyard through the connecting web loop.
3. Pull the attached energy absorbing lanyard through the connecting web loop to secure.

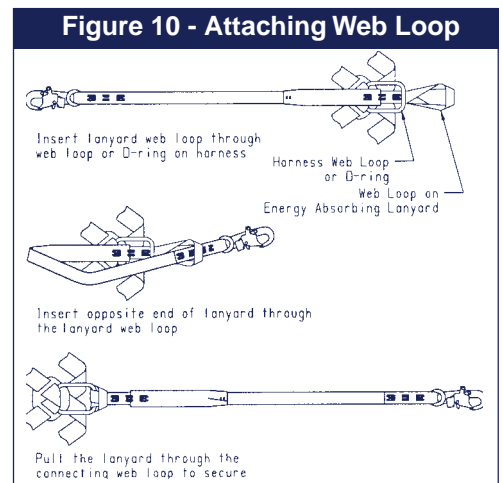
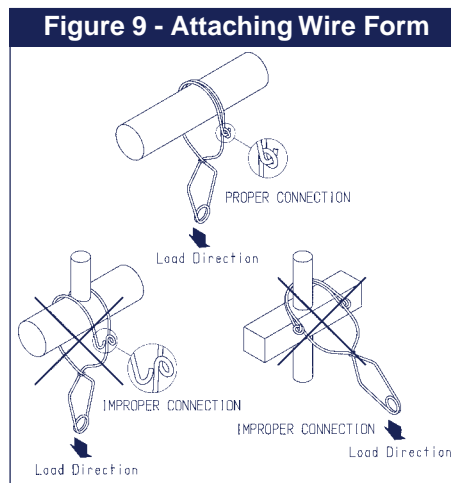
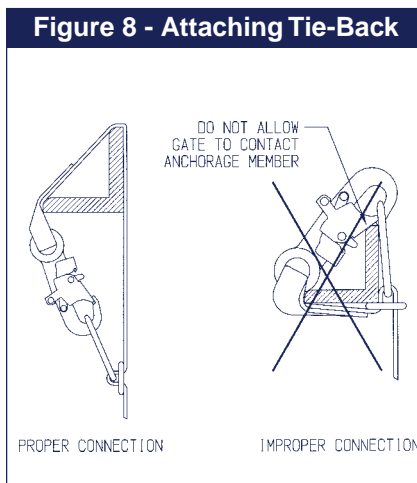

C. CONNECTING TO A ROPE GRAB (FALL ARRESTOR): It is recommended the lanyard end (vs. the energy absorber end) be attached to the rope grab. This recommendation is made to reduce possible interference with the operation of the rope grab by the energy absorber “pack”. Attaching a component style energy absorber to a rope grab is not recommended, with the exception of a “direct-coupling” between a rope grab and a harness. Some rope grabs may be supplied with a permanently attached energy absorbing lanyard. For these cases, use of an additional energy absorber connected between the rope grab and the body support is not recommended. In some cases it may be permissible to couple an energy absorber component between the anchorage (or anchorage connector) and the rope grab lifeline. In all cases, ensure the length of the energy absorber or energy absorbing lanyard does not exceed the rope grab manufacturer’s recommended maximum connection length (3 feet maximum per ANSI Z359.1).

D. CONNECTING TO SELF RETRACTING LIFELINE: DBI/SALA does not recommend connecting an energy absorbing lanyard or energy absorber component to a self retracting lifeline. Special applications do exist where it may be permissible. Contact DBI/SALA if considering connecting an energy absorbing lanyard to a self retracting lifeline.

3.4 ADJUSTING THE RETRAX™ LANYARD: The amount of the lanyard that is retracted into the Retrax housing can be adjusted by completely extending the lanyard from the housing, then sliding the housing up or down the lanyard. See Figure 11. Adjusting the length of lanyard that is retracted into the housing will not reduce the amount of fall clearance needed to arrest a fall. See section 3.2D.

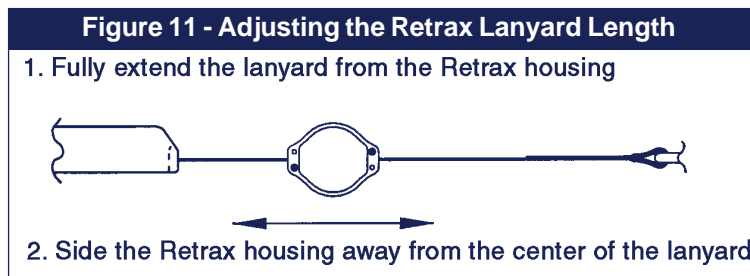

WARNING: The Retrax lanyard is designed to retract and store the lanyard strap. It is not designed to “lock” or limit the lanyard length in a fall.

3.5 After use return the lanyard for cleaning or storage as described in section 6.0

4.0 TRAINING

4.1 It is the responsibility of all users of this equipment to understand these instructions, and to be trained in the correct installation, use, and maintenance of this equipment. These individuals must be aware of the consequences of improper installation or use of this equipment. This user manual is not a substitute for a comprehensive training program. Training must be provided on a periodic basis to ensure proficiency of the users.

IMPORTANT: Training must be conducted without exposing the trainee to a fall hazard. Training should be repeated on a periodic basis.

5.0 INSPECTION

5.1 FREQUENCY

- Before each use visually inspect per steps listed in sections 5.2 and 5.3.
- The lanyard must be inspected by a competent person other than the user at least annually. See sections 5.2 and 5.3 for guidelines. Record the results of each formal inspection in the inspection log found in section 9.0.

IMPORTANT: If the energy absorbing lanyard or energy absorber component has been subjected to fall arrest or impact forces, it must be immediately removed from service and destroyed.

IMPORTANT: Extreme working conditions (harsh environment, prolonged use, etc.) may require increasing the frequency of inspections.

5.2 INSPECTION STEPS

Step 1. Inspect energy absorbing lanyard or energy absorber component hardware (snap hooks, adjusters, swages, thimbles, etc.). These items must not be damaged, broken, distorted, or have any sharp edges, burrs, cracks, worn parts, or corrosion. Ensure the connecting hooks work properly. Hook gates must move freely and lock upon closing. Ensure adjusters (if present) work properly.

Step 2. Inspect the energy absorbing lanyard or energy absorber component per the following as applicable:

WEBBING AND STITCHING: The webbing material must be free of frayed, cut, or broken fibers. Check for tears, abrasions, mold, burns, or discoloration, etc. The webbing must be free of knots, excessive soiling, heavy paint buildup, and rust staining. Check for chemical or heat damage indicated by brown, discolored, or brittle areas. Check for ultraviolet damage indicated by discoloration and the presence of splinters or slivers on the webbing surface. All of the above factors are known to reduce webbing

Figure 11 - Inspecting the Energy Absorber for Activation

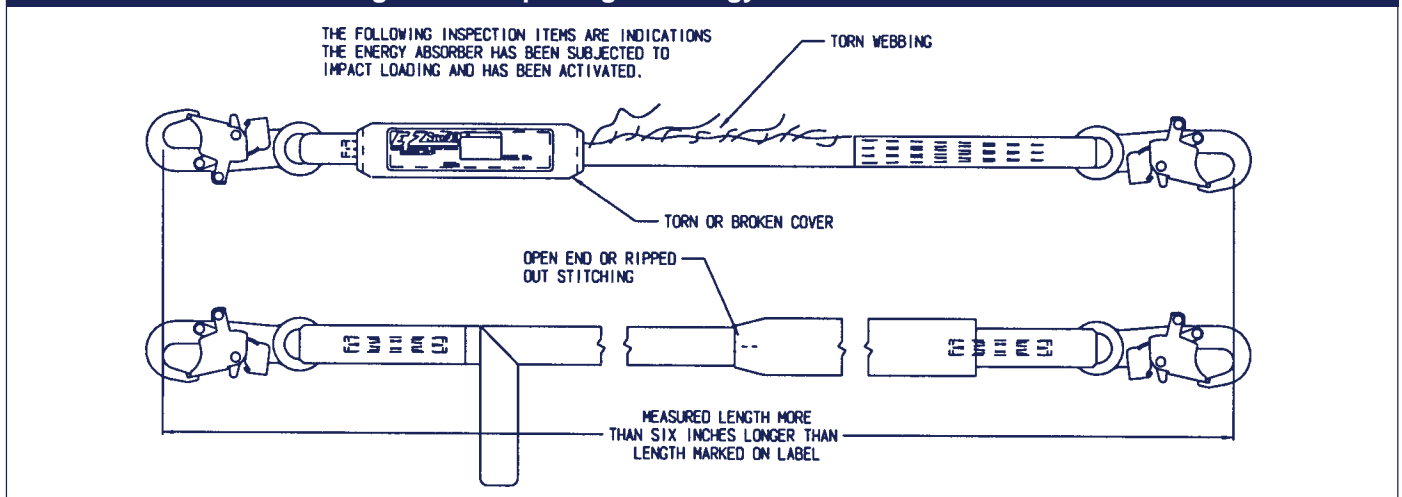

strength. Damaged or questionable webbing should be replaced. Inspect stitching for pulled or cut stitches. Broken stitches may be an indication the energy absorbing lanyard or energy absorber component has been impact loaded and must be removed from service.

WIRE ROPE: Inspect entire length of the wire rope. Always wear protective gloves when inspecting wire rope. Inspect for broken wires by passing cable through gloved hands, flexing it every few inches to expose breaks. Broken wires can be removed by bending the wire back and forth parallel to the rope length. Do not attempt to pull wires out of rope. Remove the energy absorbing lanyard from service immediately and destroy if there are six or more randomly distributed broken wires in one lay, or three or more broken wires in one strand in one lay. A “lay” of wire rope is the length of wire rope that it takes for a strand (the larger groups of wires) to complete one revolution or twist along the rope. Remove the energy absorbing lanyard from service immediately and destroy if there are any broken wires within 1 inch of the metal compression sleeves (swages) at either end of the assembly. The wire rope should be free of corrosion.

- Step 3. ENERGY ABSORBING COMPONENT:** Inspect energy absorber to determine if it has been activated. There should be no evidence of elongation. See Figure 11. Ensure energy absorber cover is secure and not torn or damaged. On the Shockwave 2™ Lanyard models, the lanyard webbing will tear out to reveal the warning on the impact indicator label. See section 8.2 for label illustration.
- Step 4.** All labels should be present and fully legible. See section 8.0.
- Step 5.** Inspect each system component or subsystem per associated manufacturer's instructions.
- Step 6.** Record the inspection date and results in the inspection log. See section 9.0.

5.3 If inspection reveals an unsafe condition, remove unit from service immediately and destroy, or contact an authorized service center for repair.

NOTE: Only DBI/SALA or parties authorized in writing may make repairs to this equipment.

6.0 MAINTENANCE, SERVICING, STORAGE

- 6.1** Clean lanyard with water and a mild detergent solution. Wipe off hardware with a clean, dry cloth, and hang to air dry. Do not force dry with heat. If you have any questions regarding cleaning of this equipment, or require more information, contact DBI/SALA. An excessive buildup of dirt, paint, etc., may prevent the lanyard from working properly, and in severe cases degrade the webbing or rope to a point where it has become weakened and should be removed from service. If you have any questions concerning the condition of your lanyard, or have any doubt about putting it into service, contact DBI/SALA.
- 6.2** Additional maintenance and servicing procedures (replacement parts) must be completed by a factory authorized service center. Authorization must be in writing. Do not disassemble the unit. See section 5.1 for inspection frequency.

6.3 Store the lanyard in a cool, dry, clean environment out of direct sunlight. Avoid areas where chemical vapors may exist. Thoroughly inspect the lanyard or energy absorber component after extended storage.

7.0 SPECIFICATIONS

- The maximum arresting force of DBI/SALA Energy Absorbing Lanyards and components when dynamically tested accordance with ANSI Z359.1 is 900 lbs.
- The maximum elongation of the Energy Absorbing Lanyard or Energy Absorber component when dynamically tested in accordance with ANSI Z359.1 is 42 inches.
- Maximum free fall distance must be no greater than 6 feet per federal law and ANSI Z359.1 (5 feet per ANSI A10.14)
- EZ STOP® II U.S. Patent Number 5,174,410
- 9503175 self closing and self locking snap hook U.S. Patent Number 4,977,647, Can. 2,027,784.

Lanyard Model	Energy Absorber Specifications	Adjustable/Fixed Length	Lanyard Specifications
Fixed Length EZ Stop II Web Lanyards	1 3/4 in. polyester web strength member, tubular nylon web wear pads both ends, nylon outer cover, polyester thread, 8,800 lb tensile strength	Fixed	1 in. polyester web, 8,800 lb tensile strength
Adjustable Length EZ Stop II Web Lanyards	1 3/4 in. polyester web strength member, tubular nylon web wear pads both ends, nylon outer cover, polyester thread, 8,800 lb tensile strength	Adjustable	1 in. polyester web, 8,800 lb tensile strength
100% Tie-off EZ Stop II Web Lanyards	1 3/4 in. polyester web strength member, tubular nylon web wear pads both ends, nylon outer cover, polyester thread, 8,800 lb tensile strength	Fixed	1 in. polyester web, 100% tie-off, 8,800 lb tensile strength
EZ Stop II Energy Absorber Component	1 3/4 in. polyester web strength member, tubular nylon web wear pads both ends, nylon outer cover, polyester thread, 8,800 lb tensile strength	Fixed	Not Applicable
EZ Stop II Cable Lanyards	1 3/4 in. polyester web strength member, nylon web wear pads both ends, nylon outer cover, polyester thread, 8,800 lb tensile strength	Fixed	7/32 in. 7x9 galvanized cable, vinyl covered, 5,600 lb. tensile strength
EZ Stop III Web Lanyards	1 3/8 in. tubular polyester web strength member, nylon web wear pads both ends, polyester thread, 8,800 lb tensile strength	Fixed	1 3/8 in. tubular polyester web strength member, 6,000 lb tensile strength
EZ Stop II Tie-back Web Lanyard	1 3/4 in. polyester web strength member, tubular nylon web wear pads both ends, nylon outer cover, polyester thread, 8,800 lb tensile strength	Fixed	1 polyester web strength member, 8,800 lb tensile strength, with 1 3/8 in. tubular polyester web cover
EZ Stop II Tie-back 100% Tie-off Web Lanyard	1 3/4 in. polyester web strength member, tubular nylon web wear pads both ends, nylon outer cover, polyester thread, 8,800 lb tensile strength	Fixed	1 polyester web strength member, 8,800 lb tensile strength, with 1 3/8 in. tubular polyester web cover
EZ Stop II Shockwave	1 3/4 in. polyester web strength member, tubular nylon web wear pads both ends, nylon outer cover, polyester thread, 8,800 lb tensile strength	Fixed	1 15/16 in. tubular polyester web strength member, 6,000 lb. tensile strength
Shockwave 2	1 15/16 in. tubular polyester web strength member, nylon web wear pads both ends, polyester thread, 8,800 lb tensile strength	Fixed	Lanyard and energy absorber are the same material.
EZ Stop II Retrax Web Lanyard	1 3/4 in. polyester web strength member, nylon web wear pads both ends, nylon outer cover, polyester thread, 6,000 lb tensile strength	Fixed	1 3/8 polyester web, 6,000 lb. tensile strength

8.2 These labels must be attached to all Energy Absorbing Lanyards or Energy Absorber components (except EZ Stop® III Shock Wave Lanyards), and fully legible.

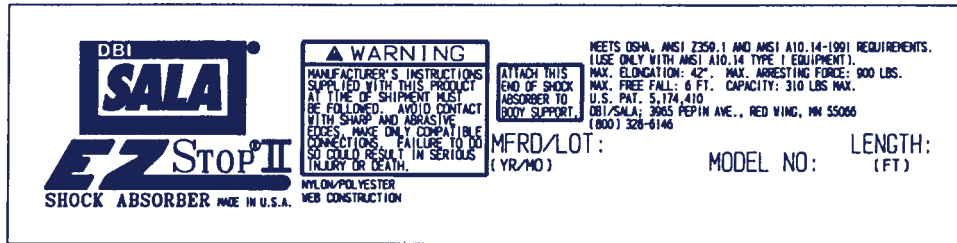

ID Label - EZ Stop® II Web Lanyards

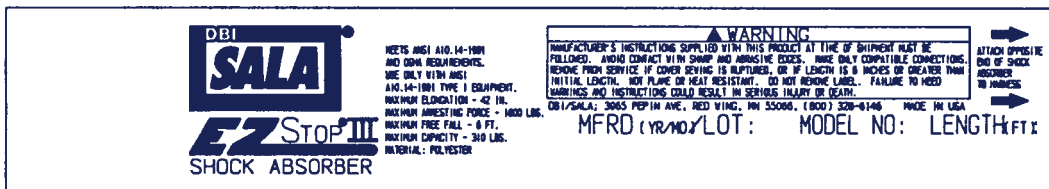

ID Label - EZ Stop® III Web Lanyards

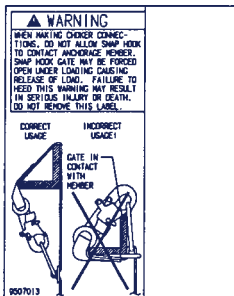

Warning Label EZ Stop® II Tie-Back Lanyards

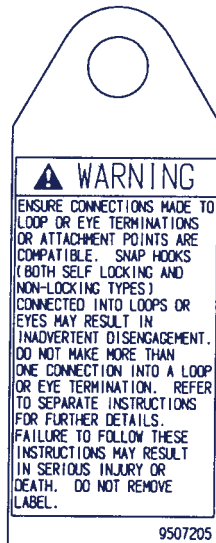

Warning Label - All Web Loop Energy Absorbing Lanyards Not Permanently Attached to Harness

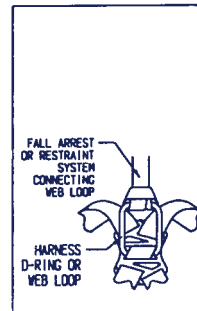

Warning Label - All Web Loop Energy Absorbing Lanyards Permanently Attached to Harness

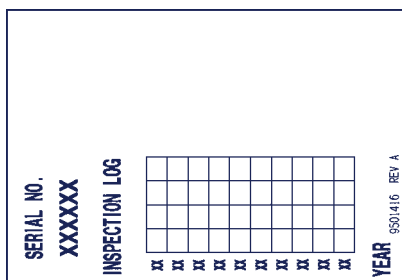
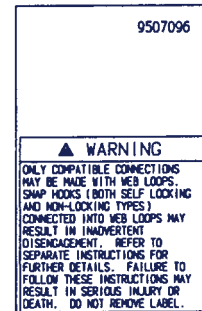

Retrax Inspection Label

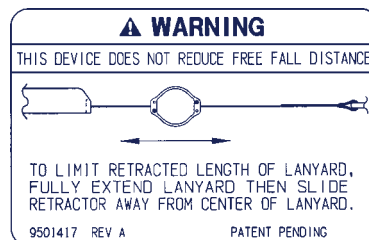

Retrax Warning Label

9.0 INSPECTION AND MAINTENANCE LOG

DATE OF MANUFACTURE: _____

MODEL NUMBER: _____

DATE PURCHASED: _____

INSPECTION DATE	INSPECTION ITEMS NOTED	CORRECTIVE ACTION	MAINTENANCE PERFORMED
Approved By: _____			
Approved By: _____			
Approved By: _____			
Approved By: _____			
Approved By: _____			
Approved By: _____			
Approved By: _____			
Approved By: _____			
Approved By: _____			
Approved By: _____			
Approved By: _____			

9.0 INSPECTION AND MAINTENANCE LOG

DATE OF MANUFACTURE: _____

MODEL NUMBER: _____

DATE PURCHASED: _____

INSPECTION DATE	INSPECTION ITEMS NOTED	CORRECTIVE ACTION	MAINTENANCE PERFORMED
Approved By: _____			
Approved By: _____			
Approved By: _____			
Approved By: _____			
Approved By: _____			
Approved By: _____			
Approved By: _____			
Approved By: _____			
Approved By: _____			
Approved By: _____			
Approved By: _____			

9.0 INSPECTION AND MAINTENANCE LOG

DATE OF MANUFACTURE: _____

MODEL NUMBER: _____

DATE PURCHASED: _____

INSPECTION DATE	INSPECTION ITEMS NOTED	CORRECTIVE ACTION	MAINTENANCE PERFORMED
Approved By: _____			
Approved By: _____			
Approved By: _____			
Approved By: _____			
Approved By: _____			
Approved By: _____			
Approved By: _____			
Approved By: _____			
Approved By: _____			
Approved By: _____			
Approved By: _____			
Approved By: _____			



USA

3965 Pepin Avenue
Red Wing, MN 55066-1837
Toll Free: 800-328-6146
Phone: (651) 388-8282
Fax: (651) 388-5065
www.salagroup.com

Canada

260 Export Boulevard
Mississauga, Ontario L5S 1Y9
Toll Free: 800-387-7484
Phone: (905) 795-9333
Fax: (905) 795-8777

This manual is available for download at www.salagroup.com.



Form: 5902143
Rev: G