

I-7005 and M-7005

User's Manual

Warranty

All products manufactured by ICP DAS are under warranty regarding defective materials for a period of one year from the date of delivery to the original purchaser.

Warning

ICP DAS assumes no liability for damages resulting from the use of this product. ICP DAS reserves the right to change this manual at any time without notification. The information furnished by ICP DAS is believed to be accurate and reliable. However, no responsibility is assumed by ICP DAS for its use, or for any infringements of patents or other rights of third parties resulting from its use.

Copyright

Copyright 1999 - 2007 ICP DAS. All rights reserved.

Trademark

The names used for identification only may be registered trademarks of their respective companies.

Date: 2011/9/16

Table of Contents

1. Introduction.....	5
1.1 More Information.....	7
1.2 Terminal Assignment.....	8
1.3 Specifications.....	9
1.4 Block Diagrams.....	10
1.4.1 Block Diagram for the I-7005/M-7005.....	10
1.5 Dimensions.....	11
1.5.1 I-7005 and M-7005 Dimensions.....	11
1.6 Wiring.....	12
1.6.1 I-7005/M-7005 Wiring.....	12
1.6.2 Wiring Recommendations.....	12
1.7 Quick Start.....	13
1.8 Default Settings.....	15
1.9 Calibration.....	16
1.10 Configuration Tables.....	18
1.11 User-defined Types.....	24
1.12 Digital Outputs and Alarms.....	26
1.13 M-7000 Notes.....	27
1.13.1 Protocol Switching.....	27
1.13.2 INIT Mode.....	28
1.14 Mounting.....	29
1.14.1 Din-Rail Mounting.....	29
1.14.2 Piggyback Mounting.....	31
1.14.3 Wall Mounting.....	31
1.15 Technical Support.....	32
2. DCON Protocol.....	33
2.1 %AANNTTCCFF.....	37
2.2 #**.....	40
2.3 #AA.....	42
2.4 #AAN.....	44
2.5 \$AA0Ci.....	46
2.6 \$AA1Ci.....	48
2.7 \$AA2.....	50
2.8 \$AA4.....	52
2.9 \$AA5.....	54

2.10	\$AA5VV	56
2.11	\$AA6	58
2.12	\$AA7CiRrr	60
2.13	\$AA8Ci	62
2.14	\$AAB	64
2.15	\$AAF	66
2.16	\$AAI	67
2.17	\$AAM	69
2.18	\$AAP	70
2.19	\$AAPN	72
2.20	\$AAS0	74
2.21	\$AAS1	75
2.22	~AAD	77
2.23	~AADT	79
2.24	~AAEV	81
2.25	~AAI (Soft INIT command)	83
2.26	~AAO(Name)	85
2.27	~AATnn	87
2.28	@AAGxTtt	90
2.29	@AARTTttR(Data)	92
2.30	@AASxTttC(data)	94
2.31	@AACHCi	96
2.32	@AACLCi	98
2.33	@AADHCi	100
2.34	@AADI	102
2.35	@AADLCi	104
2.36	@AADODD	106
2.37	@AAHI(data)CiTOj	108
2.38	@AALO(data)CiTOj	110
2.39	@AARAOj	112
2.40	@AARHCi	114
2.41	@AARLCi	116
2.42	@AAROOj	118
2.43	~**	120
2.44	~AA0	121
2.45	~AA1	123
2.46	~AA2	125
2.47	~AA3EVV	127

2.48 ~AA4.....	129
2.49 ~AA5PPSS.....	131
3. Modbus RTU Protocol.....	133
3.1 01 (0x01) Read Digital Output Status.....	134
3.2 02 (0x02) Read Input Status.....	135
3.3 04 (0x04) Read Input Channels	136
3.4 05 (0x05) Write Single Digital Output.....	137
3.5 15 (0x0F) Write Multiple Digital Output Channels.....	138
3.6 70 (0x46) Read/Write Module Settings	139
3.6.1 Sub-function 00 (0x00) Read module name	140
3.6.2 Sub-function 04 (0x04) Set module address	141
3.6.3 Sub-function 05 (0x05) Read communication settings	142
3.6.4 Sub-function 06 (0x06) Set communication settings	143
3.6.5 Sub-function 07 (0x07) Read type code.....	144
3.6.6 Sub-function 08 (0x08) Set type code.....	145
3.6.7 Sub-function 32 (0x20) Read firmware version...	146
3.6.8 Sub-function 37 (0x25) Read channel enabled/disabled status.....	147
3.6.9 Sub-function 38 (0x26) Set channel enable/disable	148
3.6.10 Sub-function 41 (0x29) Read miscellaneous settings	149
3.6.11 Sub-function 42 (0x2A) Write miscellaneous settings	150
3.7 M-7005 Address Mappings.....	151
3.8 M-7005 Engineering Data Format Table	154
4. Troubleshooting.....	155
4.1 Communicating with the module.....	156
4.2 Reading Data.....	157
A. Appendix.....	158
A.1 INIT Mode	158
A.2 Dual Watchdog Operation.....	160
A.3 Frame Ground	161
A.4 Node Information Area	163
A.5 Thermistor.....	164
A.6 Resistance Measurement.....	165

1. Introduction

The I-7000 series is a family of network data acquisition and control modules, providing analog-to-digital, digital-to-analog, digital input/output, timer/counter and other functions. The modules can be remotely controlled using a set of commands, which we call the DCON protocol. Communication between the module and the host is in ASCII format via an RS-485 bi-directional serial bus standard. Baud Rates are software programmable and transmission speeds of up to 115.2 Kbps can be selected.

Some I-7000 modules feature a new design for the frame ground and INIT switch as shown in the figure (rear view). The frame ground provides enhanced static protection (ESD) abilities and ensures the module is more reliable. The INIT switch allows easier access to INIT mode. Please refer to Sections A.1 and A.3 for more details.

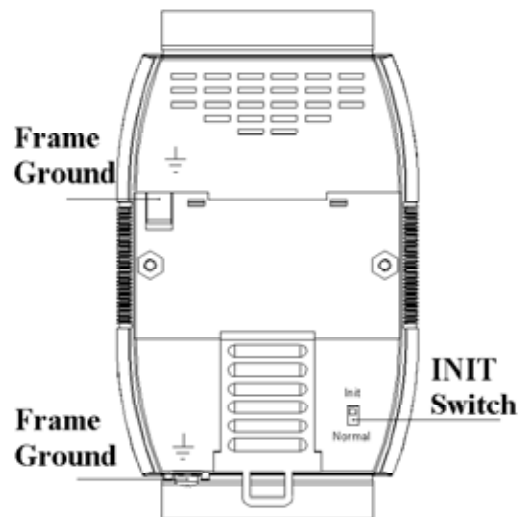

The common features of the I-7005 and M-7005 modules are as follows:

1. 24-bit sigma-delta ADC to provide excellent accuracy
2. Direct thermistor connection
3. Software calibration

The I-7005/M-7005 is an 8-channel thermistor input and 6-channel digital output module

Supported thermistor types are as follows:

1. PreCon Type III, Model 3, 10,000 Ohms at 25°C (77°F)
2. Fenwell Type U, 2000 Ohms at 25°C
3. YSI L Mix, 100 Ohms at 25°C
4. YSI L Mix, 300 Ohms at 25°C
5. YSI L Mix, 1000 Ohms at 25°C
6. YSI B Mix, 2252 Ohms at 25°C
7. YSI B Mix, 3000 Ohms at 25°C
8. YSI B Mix, 5000 Ohms at 25°C
9. YSI B Mix, 6000 Ohms at 25°C
10. YSI B Mix, 10000 Ohms at 25°C
11. YSI H Mix, 10000 Ohms at 25°C
12. YSI H Mix, 30000 Ohms at 25°C
13. User-defined

1.1 More Information

For more information regarding the I-7000 series, please refer to chapter 1 of the “I-7000 Bus Converter User’s Manual” as shown below or visit the ICP DAS website <http://www.icpdas.com>.

- 1.1 The 7000 Series Overview
- 1.2 Related Documentation for the 7000 Series
- 1.3 Common Features of the 7000 Series
- 1.4 The 7000 Series System Network Configuration
- 1.5 7000 Dimensions

1.2 Terminal Assignment

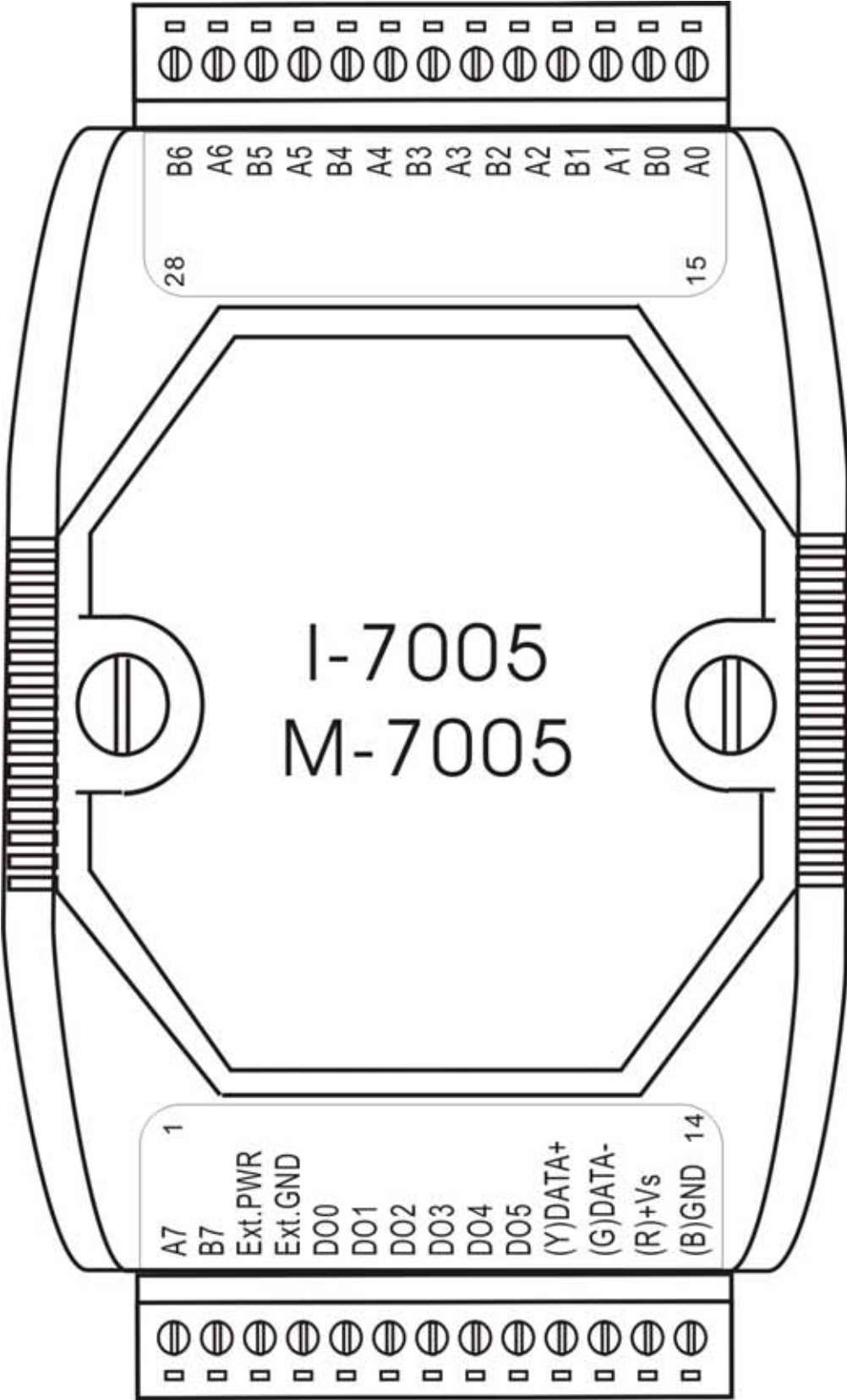

1.3 Specifications

	I-7005/M-7005
Analog Input	
Input Channels	8
Input Type	Thermistor
Thermistor Type	PreCon Type III, Fenwell Type U, YSI L 100, YSI L 300, YSI L 1000, YSI B 2252, YSI B 3000, YSI B 5000, YSI B 6000, YSI B 10000, YSI H 10000, YSI H 30000, User-defined
Temperature Scale	Celsius, Fahrenheit
Sampling Rate	8 samples/sec
Bandwidth	5.24 Hz
Accuracy	±0.1%
Zero Drift	0.5 μ V/°C
Span Drift	20 μ V/°C
CMR@50/60Hz	86 dB min
NMR@50/60Hz	100 dB min
Isolation	3000 VDC
Open Wire Detection	Yes
Individual Channel Configurable	Yes
Digital Output	
Output Channels	6
Output Type	Open collector
Output Load	30 V, 100 mA max.
Modbus RTU	M-7005
Power	
Requirement	+10 to +30 VDC
Consumption	1.1 W
Temperature Range	
Operating	-25°C to +75°C
Storage	-30°C to +75°C

Note: A warm up period of 30 minutes is recommended in order to achieve the complete performance results described in the specifications.

1.4 Block Diagrams

1.4.1 Block Diagram for the I-7005/M-7005

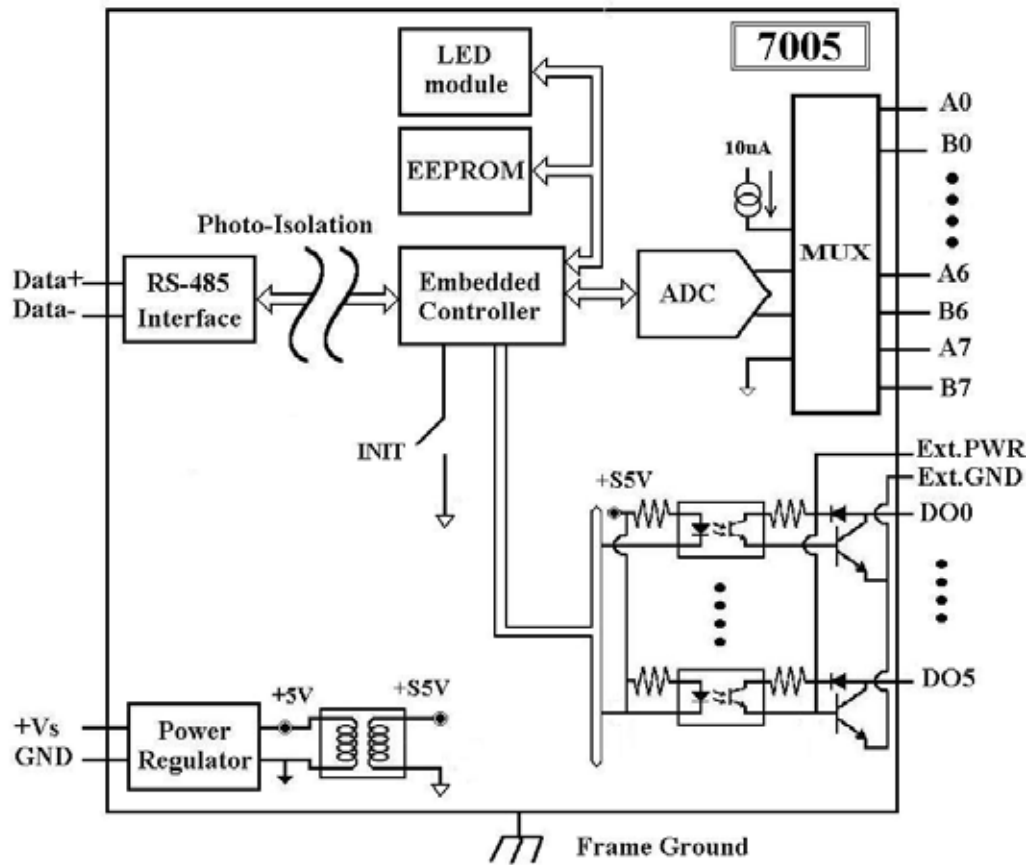

1.5 Dimensions

1.5.1 I-7005 and M-7005 Dimensions

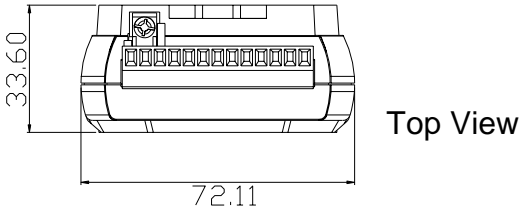
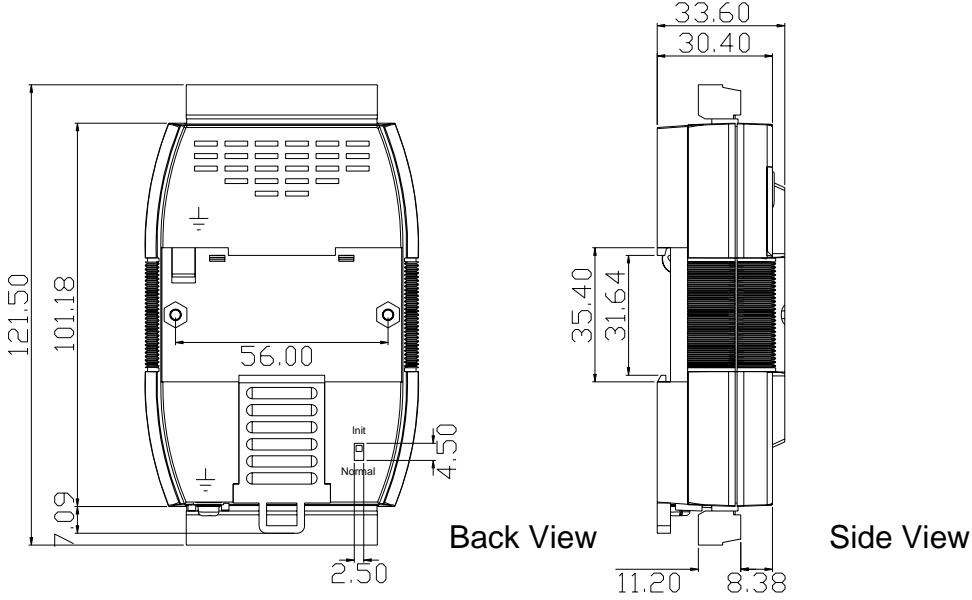

Unit : mm

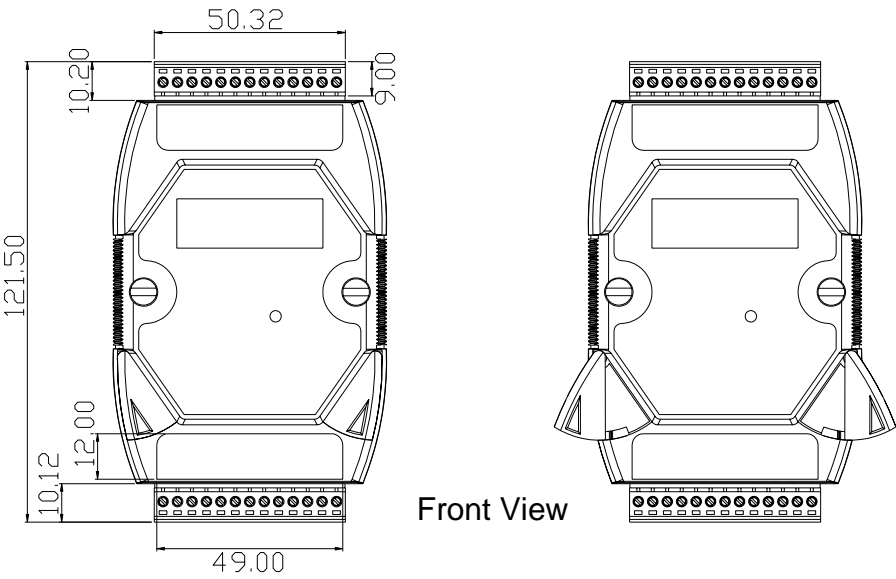

1.6 Wiring

1.6.1 I-7005/M-7005 Wiring

Thermistor connection

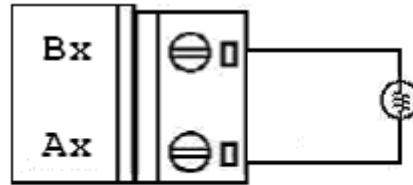

Digital output connectoin

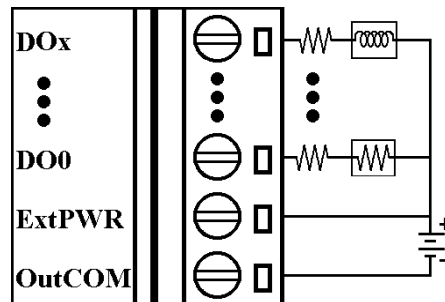

1.6.2 Wiring Recommendations

- Use 26-12 AWG wire for signal connections.
- Strip the wire to a length of 7 ± 0.5 mm.
- Use a crimp terminal for wiring.
- Avoid high-voltage cables and power equipment as much as possible.
- For RS-485 communication, use insulated and twisted pair 24 AWG wire, e.g. Belden 9841.

1.7 Quick Start

To install the module, follow the steps below:

1. Connect the thermistor sensor. See Section 1.2 for the terminal assignment and Section 1.6 for the wiring diagram.
2. Connect the module to the RS-485 network using the DATA+ and DATA- terminals. See Section 1.2 for the terminal assignment. If the host is only equipped with an RS-232 interface, then an RS-232 to RS-485 converter will be required. Refer to the “**I-7000 Bus Converter User’s Manual**” for more information.
3. Connect the module to the power supply using the +Vs and GND terminals. See Section 1.2 for the terminal assignment. Note that the voltage supplied to the module should be in the range of +10 to +30 VDC.
4. Configure the module by sending the %AANNTCCFF command. See Section 2.1 for details. To configure the I-7005, the \$AA7CiRrr command must also be sent. See Section 2.12 for details. For M-7000 modules using the Modbus RTU protocol, configure the module using the following functions.
 - Sub-function 04h of Function 46h, see Section 3.6.2
 - Sub-function 06h of Function 46h, see Section 3.6.4
 - Sub-function 08h of Function 46h, see Section 3.6.6The default settings for the module can be found in Section 1.8.
5. For the I-7005, send the ~AADT command to set the temperature scaling. See Section 2.23 for details.
6. To read data from the input channels, send either the #AA or #AAN commands to the module. See Sections 2.3 and 2.4 for details. For M-7000 modules using the Modbus RTU protocol, use Function 04h to read the

data from the input channels. See Section 3.3 for details.

7. If the host is a PC with a Windows operating system installed, the DCON Utility can be used to allow easy configuration and reading of data. The DCON Utility can be downloaded from the ICP DAS website (<http://www.icpdas.com>). The documentation for the DCON Utility can be found in the "**Getting Started For I-7000 Series Modules**" manual.

Please refer to the "**I-7000 Bus Converter User's Manual**" and "**Getting Started For I-7000 Series Modules**" manuals for more details. The "**Getting Started For I-7000 Series Modules**" manual can be downloaded from the ICP DAS website (<http://www.icpdas.com>).

1.8 Default Settings

Default settings for the I-7005 are as follows:

- Module Address: 01
- Thermistor Type: Type 60, PreCon Type III, -30°F to 240°F
- Baud Rate: 9600 bps
- Checksum disabled
- Engineering unit format
- Temperature Scale: Celsius (the I-7005 also supports Fahrenheit)

Default settings for the M-7005 modules are as follows:

- Protocol: Modbus RTU
- Module Address: 01
- Thermistor Type: Type 60, PreCon Type III, -30°F to 240°F
- Baud Rate: 9600 bps
- Temperature Scale: Celsius (the M-7005 also supports Fahrenheit for DCON protocol)

1.9 Calibration

Warning: *It is not recommended that calibration be performed until the process is fully understood.*

The calibration procedure is as follows:

1. Warm up the module for at least 30 minutes.
2. Set the type code to the type you wish to calibrate. Refer to Section 2.12 for details.
3. Enable calibration. Refer to Section 2.24 for details.
4. Connect the zero calibration resistor.
5. Send the zero calibration command. Refer to Section 2.5 for details.
6. Connect the span calibration resistor.
7. Send the span calibration command. Refer to Section 2.6 for details.
8. Repeat steps 3 to 7 three times.

Notes:

1. For the I-7005 and M-7005, each channel should be calibrated separately.
2. For the I-7005 and M-7005, types 71 to 77 must be calibrated for each channel.
3. Calibration resistors are shown on the next page.
4. The M-7000 series modules must be switched to the DCON protocol mode before calibrating. Refer to Sections 1.13.1 and 3.6.4 for details of the switching protocol.

Calibration resistor types used by the I-7005 and M-7005

For firmware version A2.3 and earlier.

Type	Zero Calibration Resistor	Span Calibration Resistor
71	0 Ohms	2700 Ohms
72	0 Ohms	5600 Ohms
73	0 Ohms	12000 Ohms
74	0 Ohms	22000 Ohms
75	0 Ohms	47000 Ohms
76	0 Ohms	91000 Ohms
77	0 Ohms	150000 Ohms

For firmware version A3.7 and later.

Type	Zero Calibration Resistor	Span Calibration Resistor
71	0 Ohms	3200 Ohms
72	0 Ohms	6400 Ohms
73	0 Ohms	12800 Ohms
74	0 Ohms	25600 Ohms
75	0 Ohms	51200 Ohms
76	0 Ohms	102400 Ohms
77	0 Ohms	204800 Ohms

1.10 Configuration Tables

Baud Rate Setting (CC)

Code	03	04	05	06	07	08	09	0A
Baud rate	1200	2400	4800	9600	19200	38400	57600	115200

Note:

For I-7005 and M-7005 firmware version A3.7 and later, bits 7 and 6 of the CC byte are used to set parity and stop bits as follows. The number of data bits is fixed to be eight.

Bits 7:6	Description
00	No parity and one stop bit
01	No parity and two stop bits
10	Even parity and one stop bit
11	Odd parity and one stop bit

For other firmware version of I-7005 and M-7005, the data bits are fixed at one start bit, eight data bits, no parity and one stop bit.

Temperature Sensor Type Setting (TT)

Type Code	Temperature Sensor Type	Temperature Range
60	PreCon Type III 10K @ 25°C	-30 °F ~ 240 °F
61	Fenwell Type U 2K @ 25°C	-50 °C ~ 150 °C
62	Fenwell Type U 2K @ 25°C	0 °C ~ 150 °C
63	YSI L Mix 100 @ 25°C	-80 °C ~ 100 °C
64	YSI L Mix 300 @ 25°C	-80 °C ~ 100 °C
65	YSI L Mix 1000 @ 25°C	-70 °C ~ 100 °C
66	YSI B Mix 2252 @ 25°C	-50 °C ~ 150 °C
67	YSI B Mix 3000 @ 25°C	-40 °C ~ 150 °C
68	YSI B Mix 5000 @ 25°C	-40 °C ~ 150 °C
69	YSI B Mix 6000 @ 25°C	-30 °C ~ 150 °C
6A	YSI B Mix 10000 @ 25°C	-30 °C ~ 150 °C
6B	YSI H Mix 10000 @ 25°C	-30 °C ~ 150 °C
6C	YSI H Mix 30000 @ 25°C	-10 °C ~ 200 °C
70	User-defined	-50 °C ~ 150 °C
71	User-defined	-50 °C ~ 150 °C
72	User-defined	-50 °C ~ 150 °C
73	User-defined	-50 °C ~ 150 °C
74	User-defined	-50 °C ~ 150 °C
75	User-defined	-50 °C ~ 150 °C
76	User-defined	-50 °C ~ 150 °C
77	User-defined	-50 °C ~ 150 °C

Note: Please refer to Section 1.11 for details of user-defined types.

Data Format Setting (FF)

7	6	5	4	3	2	1	0
FS	CS	reserved				DF	

Key	Description
DF	Data format 00: Engineering unit 01: % of FSR (full scale range) 10: 2's complement hexadecimal 11: Ohms
CS	Checksum setting 0: Disabled 1: Enabled
FS	This setting is reserved for the I-7005 and M-7005 and should be zero.

Note: The reserved bits should be zero.

Thermistor Type and Data Format Table

Type Code	Thermistor Type	Data Format	+F.S.	-F.S.
60	PreCon Type III 10K @ 25°C -30 ~ 240°F	Engineering unit	+240.00	-030.00
		% of FSR	+100.00	-012.50
		2's comp HEX	7FFF	F000
		Ohms	+000539.4	+173600.0
61	Fenwell U 2K @ 25°C -50 ~ 150°C	Engineering unit	+150.00	-050.00
		% of FSR	+100.00	-033.33
		2's comp HEX	7FFF	D556
		Ohms	+000037.2	+134020.0
62	Fenwell U 2K @ 25°C 0 ~ 150°C	Engineering unit	+150.00	+000.00
		% of FSR	+100.00	+000.00
		2's comp HEX	7FFF	0000
		Ohms	+000037.2	+006530.0
63	YSI L Mix 100 @ 25°C -80 ~ 100°C	Engineering unit	+100.00	-080.00
		% of FSR	+100.00	-080.00
		2's comp HEX	7FFF	999A
		Ohms	+000014.3	+014470.0
64	YSI L Mix 300 @ 25°C -80 ~ 100°C	Engineering unit	+100.00	-080.00
		% of FSR	+100.00	-080.00
		2's comp HEX	7FFF	999A
		Ohms	+000035.8	+067660.0
65	YSI L Mix 1000 @ 25°C -70 ~ 100°C	Engineering unit	+100.00	-070.00
		% of FSR	+100.00	-070.00
		2's comp HEX	7FFF	A667
		Ohms	+000106.4	+132600.0
66	YSI B Mix 2252 @ 25°C -50 ~ 150°C	Engineering unit	+150.00	-050.00
		% of FSR	+100.00	-033.33
		2's comp HEX	7FFF	D556
		Ohms	+000041.8	+151000.0
67	YSI B Mix 3000 @ 25°C -40 ~ 150°C	Engineering unit	+150.00	-040.00
		% of FSR	+100.00	-026.67
		2's comp HEX	7FFF	DDDE
		Ohms	+000055.6	+101000.0

Type Code	Thermistor Type	Data Format	+F.S.	-F.S.
68	YSI B Mix 5000 @ 25°C -40 ~ 150°C	Engineering unit	+150.00	-040.00
		% of FSR	+100.00	-026.67
		2's comp HEX	7FFF	DDDE
		Ohms	+000092.7	+168300.0
69	YSI B Mix 6000 @ 25°C -30 ~ 150°C	Engineering unit	+150.00	-030.00
		% of FSR	+100.00	-020.00
		2's comp HEX	7FFF	E667
		Ohms	+000111.5	+106200.0
6A	YSI B Mix 10K @ 25°C -30 ~ 150°C	Engineering unit	+150.00	-030.00
		% of FSR	+100.00	-020.00
		2's comp HEX	7FFF	E667
		Ohms	+000185.9	+177000.0
6B	YSI H Mix 10K @ 25°C -30 ~ 150°C	Engineering unit	+150.00	-030.00
		% of FSR	+100.00	-020.00
		2's comp HEX	7FFF	E667
		Ohms	+000237.0	+135200.0
6C	YSI H Mix 30K @ 25°C -10 ~ 200°C	Engineering unit	+200.00	-010.00
		% of FSR	+100.00	-005.00
		2's comp HEX	7FFF	F99A
		Ohms	+000186.7	+158000.0
70 ~ 77	User-defined -50 ~ 150°C	Engineering unit	+150.00	-050.00
		% of FSR	+100.00	-033.33
		2's comp HEX	7FFF	D556
		Ohms	+000000.0	+000000.0

Note:

1. For user-defined types, if the resistance is larger than 180000 ohms, then it is treated as under range. It is 204800 ohms for firmware A3.7 and later.
2. Refer to Section 1.11 for more information regarding user-defined types.

Thermistor Over Range/Under Range Reading for the I-7005 and M-7005

	Over Range	Under Range
Engineering Unit	+9999.9	-9999.9
% of FSR	+999.99	-999.99
2's Complement HEX	7FFF	8000

Thermistor Over Range/Under Range Reading for the M-7005 with Modbus RTU protocol

Over Range	Under Range
7FFFh	8000h

1.11 User-defined Types

For a typical thermistor, the relationship between resistance and temperature can be expressed by the Steinhart–Hart equation

$$1/T = A + B \ln R_T + C (\ln R_T)^3$$

where R_T is the resistance in ohms at temperature T in degrees Kelvin ($K = ^\circ C + 273.15$). The values of A , B , and C are called Steinhart Coefficients. The error of the equation is less than $\pm 0.01^\circ C$ in a $100^\circ C$ span.

I-7005 and M-7005 support user-defined types by specifying the Steinhart coefficients using the `@AASxTttC(data)` command, see Section 2.30. The data sent is a 32-bit hexadecimal value in IEEE-754 standard format:

Bits	Description
31 (sign)	0 = positive, 1 = negative
30-23 (exponent)	The exponent base is 2. The actual exponent is calculated by subtracting 127 from the stored value.
22-00 (mantissa)	The mantissa is expressed as 1.f where f is the fractional part and is stored in this field.

Example:

For the hexadecimal value C3694000h

1. Bit 31 is 1, indicating a negative number.
2. The value of bits 30-23 is 10000110 binary or 134 decimal. The exponent is 7, $134 - 127$.
3. The mantissa is 1.110100101000000000000000 binary.
4. Adjust the mantissa for the exponent. The adjusted mantissa is 11101001.0100000000000000 binary. That is 233.25 decimal.
5. Considering the sign bit. The floating-point number of C3694000h is -233.25 .

The following methods can be used to obtain the Steinhart Coefficients of a thermistor.

1. Ask the manufacturer. Usually, thermistor manufacturers publish data for the Steinhart Coefficients for their thermistor products.
2. Solve the coefficients by using three known data sets: (R1, T1), (R2, T2) and (R3, T3), which can be obtained by referring to the published Resistance versus Temperature data table of the thermistor. They can be obtained by measurement if no published data table is available. In order to achieve the most accurate results, the following values are recommended:
 $-40^{\circ}\text{C} \leq T1, T2, T3 \leq 150^{\circ}\text{C}$ and
 $|T2 - T1| \leq 50^{\circ}\text{C}, |T3 - T2| \leq 50^{\circ}\text{C}.$

The DCON Utility, available for download from the ICP DAS website (<http://www.icpdas.com>), can assist with the calculation of the Steinhart Coefficients and the conversion to IEEE-754 format. Documentation for the DCON Utility can be found in the "**Getting Started For I-7000 Series Modules**" manual.

1.12 Digital Outputs and Alarms

The I-7005/M-7005 supports digital outputs that can also be used as alarm outputs. When a host watchdog timeout occurs, the “safe value” is loaded into the digital output ports. The digital output command `@AADODD`, see Section 2.36, has no effect on the digital output ports until the host watchdog timeout status is cleared. See Section A.2 for host watchdog details. If the host watchdog timeout status has not been cleared when the module is powered on, then the safe value is loaded into the digital output ports. Otherwise, the “power-on value” is loaded into the digital output ports.

The alarm function is performed by comparing the analog input value to the high/low limits stored in the non-volatile memory. The result of the limit check can then be used to control a digital output port. All digital output ports can be used as an alarm output and are programmable. When a digital output port is associated with an alarm, it is not affected by the safe value, power-on value or the digital output command `@AADODD`. There are two types of alarm:

1. **Momentary alarm:** The alarm status is set only when the analog input value exceeds the alarm limitation. When the analog input value is within the limit, the alarm status is cleared.
2. **Latched alarm:** The alarm status is set when the analog input value exceeds the alarm limitation. After that, it is cleared only when the clear latched alarm command is sent.

Use the set high/low alarm commands, see Sections 2.37 and 2.38, to set the alarm limit, alarm type, alarm checking channel and alarm port.

1.13 M-7000 Notes

The main difference between the I-7000 and M-7000 series is that the M-7000 series has additional support for the Modbus RTU communication protocol, which is the default protocol of the M-7000 series. The communication Baud Rates for the Modbus RTU protocol can be in the range of 1200 bps to 115200 bps, and the parity, data and stop bits are fixed as no parity, 8 data bits and 1 stop bit.

Modbus functions supported by the module are described in Chapter 3.

1.13.1 Protocol Switching

To switch to the DCON protocol:

1. Uses sub-function 06h of the function 46h and set byte 8 to a value of 1. See Section 3.6.4 for details.
2. After a power-on reset, the communication protocol will be changed to DCON.

To switch to the Modbus RTU protocol:

1. Sends the \$AAPN command and set N to a value of 1. Note that for the M-7005, the slide switch on the rear side of the module should be set to the INIT position, see the figure on the next page. See Section 2.19 for details.
2. After a power-on reset, the communication protocol will be changed to the Modbus RTU protocol.

1.13.2 INIT Mode

When the module is powered on, with the rear slide switch set to the INIT position as shown in the figure below for the M-7005, the module is in INIT mode, (see Section A.1 for details), and the communication settings are as follows:

1. Address: 00
2. Baud Rate: 9600 bps
3. No checksum
4. Protocol: DCON

If communication with the module is not possible, set the module to the INIT mode and use the above settings to communicate with the module. To read the current settings, send the commands \$AA2, (see Section 2.7), and \$AAP, (see Section 2.18). To set new settings, send the commands %AANN TTCCFF, (see Section 2.1) and \$AAPN, (see Section 2.19). The new communication settings will be effective after the next power-on reset.

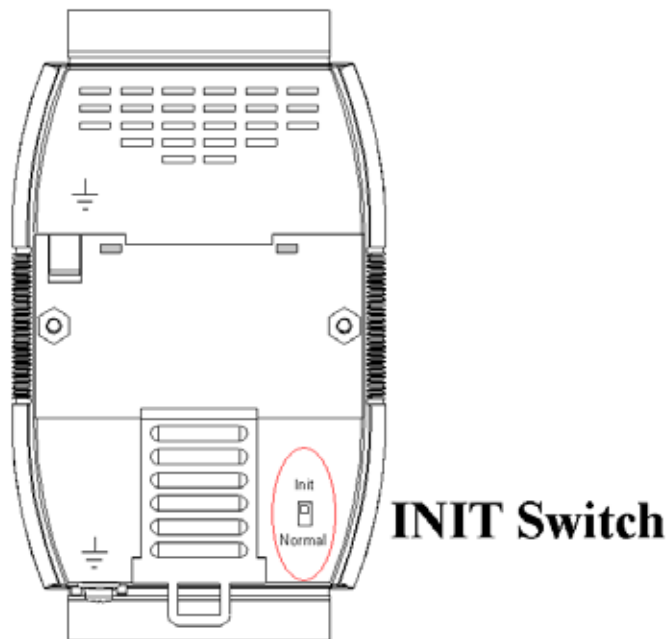

1.14 Mounting

1.14.1 Din-Rail Mounting

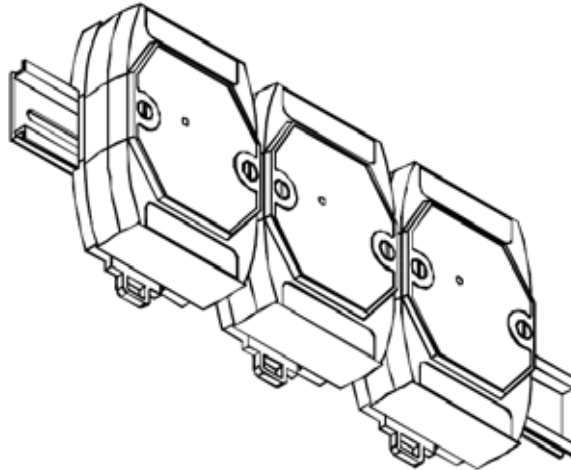

There are three new DIN rail models available. Each is made of stainless steel, which is stronger than those made of aluminum. There is a screw at one end and a ring terminal is included so that it can be easily connected to the earth ground. The three new DIN rail models are as follows.

Part number	Max. number of modules	Dimensions
DRS-360	5	360mm x 35mm

A perspective view of a DIN rail assembly with five modules mounted on it. A ring terminal is attached to the end of the rail, and a wire is connected to it. An arrow points from the text 'to earth ground' to the wire.

to earth ground

Part number	Max. number of modules	Dimensions
DRS-240	3	240mm x 35mm

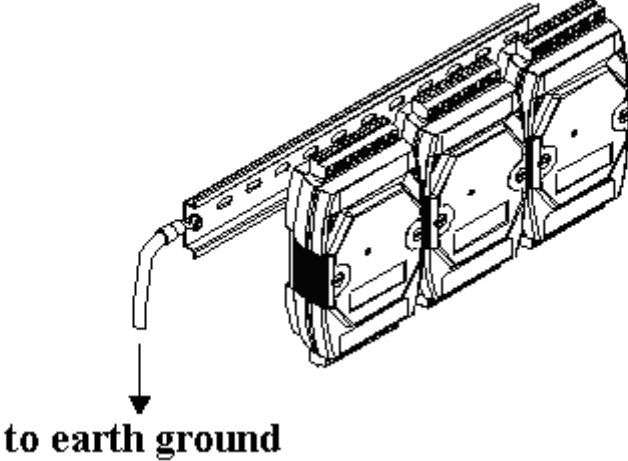

to earth ground

Part number	Max. number of modules	Dimensions
DRS-125	2	125mm x 35mm

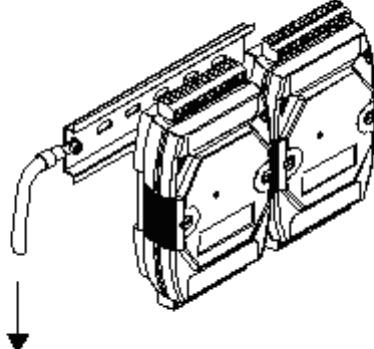

to earth ground

Note: It is recommended that a 16 – 14 AWG wire is used to connect the DIN rail to the earth ground.

1.14.2 Piggyback Mounting

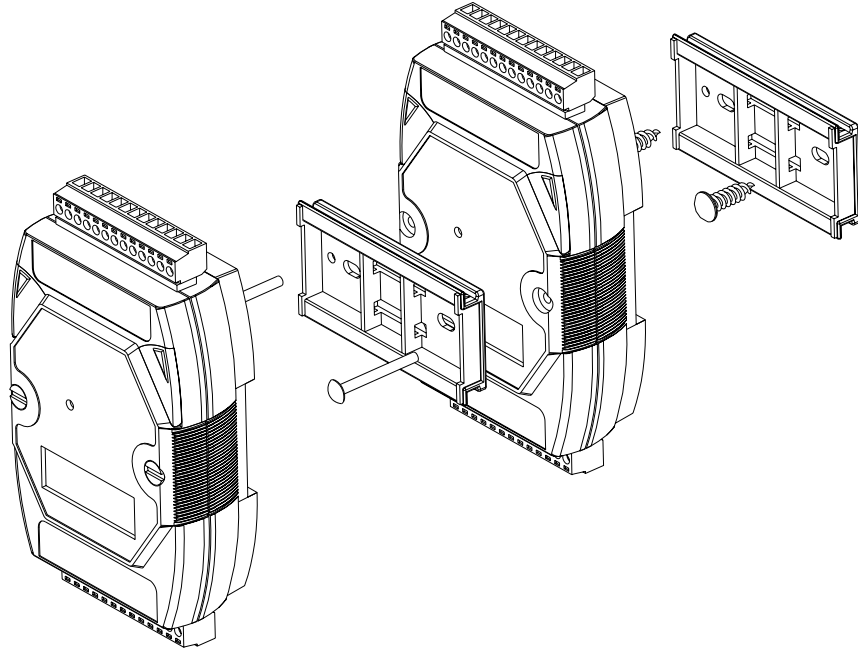

1.14.3 Wall Mounting

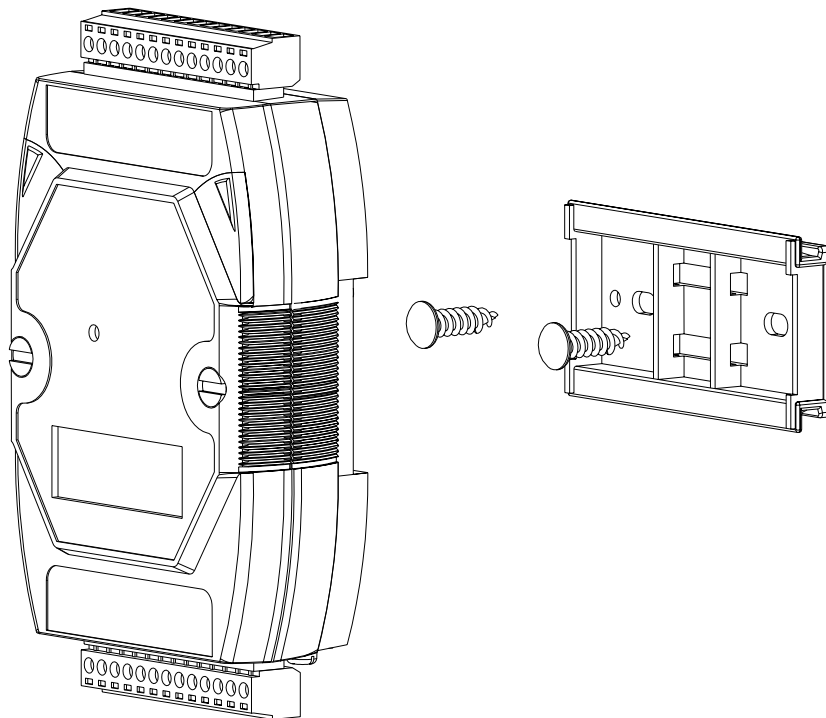

1.15 Technical Support

Should you encounter any problems while using the I-7000 and M-7000 module, and are unable to find the help you need in this manual or on our website, please contact ICP DAS Product Support.

Email: support@icpdas.com

Website: <http://www.icpdas.com/service/support.htm>

When requesting technical support, be prepared to provide the following information about your system:

1. Module name and serial number: The serial number can be found printed on the barcode label attached to the cover of the module.
2. Firmware version: See Section 2.15 and 3.6.7 for information regarding the command used to identify the firmware version.
3. Host configuration (type and operating system)
4. If the problem is reproducible, please give full details describing the procedure used to reproduce the problem.
5. Any specific error messages displayed. If a dialog box with an error message is displayed, please include the full text of the dialog box, including the text in the title bar.
6. If the problem involves other programs or hardware devices, please describe the details of the problem in full.
7. Any comments and suggestions related to the problem are welcome.

ICP DAS will reply to your request by email within three business days.

2. DCON Protocol

All communication with I-7000 modules consists of commands generated by the host and responses transmitted by the I-7000 modules. Each module has a unique ID number that is used for addressing purposes and is stored in non-volatile memory. The ID is 01 by default and can be changed using a user command. All commands to the modules contain the ID address, meaning that only the addressed module will respond. The only exception to this is commands **#**** (Section 2.2) and **~**** (Section 2.43), which are sent to all modules, but in both of these cases, the modules do not reply to the command.

Command Format:

Leading Character	Module Address	Command	[CHKSUM]	CR
--------------------------	-----------------------	----------------	-----------------	-----------

Response Format:

Leading Character	Module Address	Data	[CHKSUM]	CR
--------------------------	-----------------------	-------------	-----------------	-----------

CHKSUM A 2-character checksum which is present when the checksum setting is enabled. See Sections 1.10 (Data Format Setting) and 2.1 for details.

CR End of command character, carriage return (0x0D)

Checksum Calculation:

1. Calculate the ASCII code sum of all the characters in the command/response string except for the carriage return character (CR).
2. The checksum is equal to the sum masked by 0FFh.

Example:

Command string: \$012(CR)

1. Sum of the string = “\$”+”0”+”1”+”2” =
 $24h+30h+31h+32h = B7h$
2. Therefore the checksum is B7h, and so
CHKSUM = “B7”
3. The command string with the checksum = \$012B7(CR)

Response string: !01200600(CR)

1. Sum of the string =
“!”+”0”+”1”+”2”+”0”+”0”+”6”+”0”+”0” =
 $21h+30h+31h+32h+30h+30h+36h+30h+30h = 1AAh$
2. Therefore the checksum is AAh, and so
CHKSUM = “AA”
3. The response string with the checksum
= !01200600AA(CR)

Note:

All characters should be in upper case.

General Command Sets			
Command	Response	Description	Section
%AANNTTCCFF	!AA	Sets the module configuration	2.1
#**	No Response	Synchronized sampling	2.2
#AA	>(Data)	Reads the analog inputs of all channels	2.3
#AAN	>(Data)	Reads the analog input of a specified channel	2.4
\$AA0Ci	!AA	Performs a single channel zero calibration	2.5
\$AA1Ci	!AA	Performs a single channel span calibration	2.6
\$AA2	!AANNTTCCFF	Reads the module configuration	2.7
\$AA4	>AAS(Data)	Reads the synchronized data	2.8
\$AA5	!AAS	Reads the module reset status	2.9
\$AA5VV	!AA	Enables/Disables a channel	2.10
\$AA6	!AAVV	Reads the channel enabled/disabled status	2.11
\$AA7CiRrr	!AA	Sets a single channel range configuration	2.12
\$AA8Ci	!AACiRrr	Reads a single channel range configuration	2.13
\$AAB	!AANN	Reads the channel diagnostic status	2.14
\$AAF	!AA(Data)	Reads the firmware version	2.15
\$AAI	!AAS	Reads the INIT status	2.16
\$AAM	!AA(Data)	Reads the module name	2.17
\$AAP	!AASC	Reads the communication protocol	2.18
\$AAPN	!AA	Sets the communication protocol	2.19
\$AAS0	!AA	Internal Calibration	2.20
\$AAS1	!AA	Reloads the default calibration parameters	2.21
~AAD	!AAT	Reads the temperature scaling	2.22
~AADT	!AA	Sets the temperature scaling to either °C or °F	2.23
~AAEV	!AA	Enables/Disables calibration	2.24
~AAI	!AA	Soft INIT	2.25
~AAO(Name)	!AA	Sets the module name	2.26
~AATnn	!AA	Sets the soft INIT timeout	2.27

User-defined Thermistor Type Setting Command Sets			
Command	Response	Description	Section
@AAGxTt	!AA(data)	Reads the Steinhart coefficient of a user-defined type	2.28
@AARTTtR(data)	!AA(data)	Reads the temperature corresponding to the resistance of a user-defined type	2.29
@AASxTtC(data)	!AA	Sets the Steinhart coefficient of a user-defined type	2.30

Digital Output and Alarm Command Sets			
Command	Response	Description	Section
@AACHCi	!AA	Clears the high latched alarm	2.31
@AACLCi	!AA	Clears the low latched alarm	2.32
@AADHCi	!AA	Disables the high alarm	2.33
@AADI	!AAOO	Reads the DO status	2.34
@AADLCi	!AA	Disables the low alarm	2.35
@AADODD	!AA	Sets the DO status	2.36
@AAHI(data)CiTOj	!AA	Sets the high alarm	2.37
@AALO(data)CiTOj	!AA	Sets the low alarm	2.38
@AARAOj	!AAHLL	Reads the current alarms associated with a DO port	2.39
@AARHCi	!AA(data)SOj	Reads the high alarm setting	2.40
@AARLCi	!AA(data)Soj	Reads the low alarm setting	2.41
@AAROOj	!AAHLL	Reads the alarms associated with a DO port	2.42

Host Watchdog Command Sets			
Command	Response	Description	Section
~**	No Response	Host is OK	2.43
~AA0	!AASS	Reads the host watchdog status	2.44
~AA1	!AA	Resets the host watchdog status	2.45
~AA2	!AAETT	Reads the host watchdog timeout settings	2.46
~AA3ETT	!AA	Sets the host watchdog timeout settings	2.47
~AA4	!AAPPSS	Reads the power-on value and safe value	2.48
~AA5PPSS	!AA	Sets the power-on value and safe value	2.49

2.1 %AANNTTCCFF

Description:

Sets the configuration of an analog input module.

Syntax:

%AANNTTCCFF[CHKSUM](CR)

- %** Delimiter character
- AA** Address of the module to be configured in hexadecimal format (00 to FF)
- NN** New address of the module in hexadecimal format (00 to FF)
- TT** New type code, see Section 1.10 for details. Not used by the I-7005 and M-7005. For the I-7005 and M-7005, use the \$AA7CiRrr command to set the type of each channel, see Section 2.12 for details.
- CC** New Baud Rate code, see Section 1.10 for details. For the I-7005 and M-7005, the rear slide switch must be moved to the INIT position in order to change Baud Rates. See Section A.1 for details.
- FF** Used to set the data format, checksum, and filter settings (Section 1.10). For the I-7005 and M-7005, the rear slide switch must be moved to the INIT position in order to change the checksum setting. See Section A.1 for details.

Response:

Valid Command: **!AA[CHKSUM](CR)**

Invalid Command: **?AA[CHKSUM](CR)**

! Delimiter for a valid command

? Delimiter for an invalid command. If the **Baud Rate** or **checksum** settings are changed without switching the rear slide switch to the INIT position, the module will return an invalid command.

AA Address of the module in hexadecimal format (00 to FF)

There will be no response if the command syntax is incorrect, there is a communication error, or there is no module with the specified address.

Examples:

Command: %0102200600 Response: !02

Changes the address of module 01 to 02. The module returns a valid response.

Command: %0202200603 Response: !02

Sets the data format of module 02 to be 3 (Ohms). The module returns a valid response.

Command: %0101200A00 Response: ?01

Changes the Baud Rate of module 01 to 115200bps. The module returns an invalid command, because it is not in INIT* mode.

Command: %0101200A00 Response: !01
Changes the Baud Rate of module 01 to 115200bps and the module is in INIT* mode. The module returns a valid response.

Related Commands:

Section 2.7 \$AA2, Section 2.25 ~AAI, Section 2.27 ~AATnn

Related Topics:

Section 1.10 Configuration Tables, Section A.1 INIT* pin Operation

Notes:

1. Changes to the address, type code and data format settings take effect immediately after a valid command is received. Changes to the Baud Rate and checksum settings take effect on the next power-on reset.
2. For the I-7005 and M-7005, changing the Baud Rate and checksum settings can be achieved by software only and is performed by using the following commands:
 - I. Send a ~AATnn command. See Section 2.27 for details.
 - II. Send a ~AAI command. See Section 2.25 for details.
 - III. Send a %AANNTTCCFF command.
If the command is valid, the Baud Rate and checksum settings will be changed after the module responds with !AA.

2.2 #**

Description:

When the command is received, it will allow all analog input modules to read data from all input channels and will store the data for later retrieval.

Syntax:

#**[CHKSUM](CR)

Delimiter character

** Synchronized sampling command

Response:

There is no response with this command. To access the data, another command, \$AA4, must be sent, see Section 2.8 for details.

Examples:

Command: #** No response

Sends the synchronized sampling command.

Command: \$014 Response: >011+025.123

Sends a command to read the synchronized data. The status byte of the response is 1, which means that it is the first time the synchronized data has been read after the previous #** command.

Command: \$014 Response: >010+025.123

Sends a command to read the synchronized data. The status byte of the response is 0, which means that it is **NOT** the first time the synchronized data has been read after the previous #** command.

Related Commands:

Section 2.8 \$AA4

2.3 #AA

Description:

Reads the data from all analog input channels.

Syntax:

#AA[CHKSUM](CR)

Delimiter character

AA Address of the module to be read (00 to FF)

Response:

Valid Command: **>(Data)[CHKSUM](CR)**

Invalid Command: **?AA[CHKSUM](CR)**

> Delimiter character for a valid command

? Delimiter character for an invalid command

(Data) Data from all analog input channels, see Section 1.10 for the data format. For both the I-7005 and M-7005, data from disabled channels is filled with space characters.

AA Address of the responding module (00 to FF)

There will be no response if the command syntax is incorrect, there is a communication error, or there is no module with the specified address.

Examples:

Command: #01 Response: >+026.35

 Reads module 01 and receives the data in engineering format.

Command: #02 Response: >4C53

 Reads module 02 and receives the data in hexadecimal format.

Command: #03 Response: >-9999.9

 Reads module 03 and the data is under range.

Command: #04 Response: >+025.12+054.12+150.12

 Reads module 04, an I-7033, and receives the data from 3 channels.

Related Commands:

Section 2.1 %AANNTTCCFF, Section 2.7 \$AA2

Related Topics:

Section 1.10 Configuration Tables

2.4 #AAN

Description:

Reads the analog input of channel N.

Syntax:

#AAN[CHKSUM](CR)

- # Delimiter character
- AA Address of the module to be read (00 to FF)
- N The channel to be read, zero based.

Response:

Valid Command: **>(Data)[CHKSUM](CR)**

Invalid Command: **?AA[CHKSUM](CR)**

- > Delimiter character for a valid command
- ? Delimiter character for an invalid command. An invalid command is returned if the specified channel is incorrect.
- (Data) Analog input data of the specified channel, see Section 1.10 for the data format. For the I-7005 and M-7005, if the specified channel is disabled, then the data field will be filled with space characters.
- AA Address of the responding module (00 to FF)

There will be no response if the command syntax is incorrect, there is a communication error, or there is no module with the specified address.

Examples:

Command: #032

Response: >+025.13

Reads data from channel 2 of module 03.

Command: #029

Response: ?02

Reads data from channel 9 of module 02. An error is returned because channel 9 is invalid.

Related Commands:

Section 2.1 %AANNTCCFF, Section 2.7 \$AA2

Related Topics:

Section 1.10 Configuration Tables

2.5 \$AA0Ci

Description:

Performs a zero calibration on the specified channel.

Syntax:

\$AA0Ci[CHKSUM](CR)

\$ Delimiter character

AA Address of the module to be calibrated (00 to FF)

0 Command for the zero calibration

Ci Specifies the channel to be calibrated

Response:

Valid Command: **!AA[CHKSUM](CR)**

Invalid Command: **?AA[CHKSUM](CR)**

! Delimiter character for a valid command

? Delimiter character for an invalid command.

An invalid command is returned if the specified channel is incorrect.

AA Address of the responding module (00 to FF)

There will be no response if the command syntax is incorrect, there is a communication error, or there is no module with the specified address.

Examples:

- Command: \$010C0 Response: !01
Performs a zero calibration on channel 0 of module 01 and returns a valid response.
- Command: \$020C5 Response: !02
Performs a zero calibration on channel 5 of module 02 and returns a valid response.
- Command: \$030C1 Response: ?03
Performs a zero calibration on channel 1 of module 03. An invalid command is returned because the “enable calibration” command was not sent in advance.

Related Commands:

Section 2.6 \$AA1Ci, Section 2.24 ~AAEV

Related Topics:

Section 1.9 Calibration

Notes:

The “enable calibration” command, ~AAEV, must be sent before this command is used, see Section 1.9 for details.

2.6 \$AA1Ci

Description:

Performs a span calibration on the specified channel.

Syntax:

\$AA1Ci[CHKSUM](CR)

\$ Delimiter character

AA Address of the module to be calibrated (00 to FF)

1 Command for the span calibration

Ci Specifies the channel to be calibrated

Response:

Valid Command: **!AA[CHKSUM](CR)**

Invalid Command: **?AA[CHKSUM](CR)**

! Delimiter character for a valid command

? Delimiter character for an invalid command.

An invalid command is returned if the specified channel is incorrect.

AA Address of the responding module (00 to FF)

There will be no response if the command syntax is incorrect, there is a communication error, or there is no module with the specified address.

Examples:

Command: \$011C0 Receive: !01
Performs a span calibration on channel 0 of module 01 and returns a valid response.

Command: \$021C5 Receive: !02
Performs a span calibration on channel 5 of module 02 and returns a valid response.

Command: \$031C1 Receive: ?03
Performs a span calibration on channel 1 of module 03. An invalid command is returned because the “enable calibration” command was not sent in advance.

Related Commands:

Section 2.5 \$AA0Ci, Section 2.24 ~AAEV

Related Topics:

Section 1.9 Calibration

Notes:

The “enable calibration” command, ~AAEV, must be sent before this command is used, see Section 1.9 for details.

2.7 \$AA2

Description:

Reads the module configuration.

Syntax:

\$AA2[CHKSUM](CR)

\$ Delimiter character
AA Address of the module to be read (00 to FF)
2 Command to read the module configuration

Response:

Valid Command: **!AATTCFF[CHKSUM](CR)**

Invalid Command: **?AA[CHKSUM](CR)**

! Delimiter character for a valid command
? Delimiter character for an invalid command
AA Address of the responding module (00 to FF)
TT Type code of the module, see Section 1.10 for details.
CC Baud Rate code of the module, see Section 1.10 for details.
FF Data format, checksum settings and filter settings of the module, see Section 1.10 for details.

There will be no response if the command syntax is incorrect, there is a communication error, or there is no module with the specified address.

Examples:

Command: \$012 Response: !01200600

Reads the configuration of module 01.

Command: \$022 Response: !02230602

Reads the configuration of module 02.

Related Commands:

Section 2.1 %AANNTTCFF

Related Topics:

Section 1.10 Configuration Tables

2.8 \$AA4

Description:

Reads the synchronized data that was retrieved by the last **##*** command.

Syntax:

\$AA4[CHKSUM](CR)

- \$ Delimiter character
- AA Address of the module to be read (00 to FF)
- 4 Command to read the synchronized data

Response:

Valid Command: **>AAS(Data)[CHKSUM](CR)**

Invalid Command: **?AA[CHKSUM](CR)**

- ! Delimiter character for a valid command
- ? Delimiter character for an invalid command
- AA Address of the responding module (00 to FF)
- S Status of the synchronized data
 - 1: first read
 - 0: not the first read
- (Data) Synchronized data. See Section 1.10 for the data format. For the I-7005 and M-7005 modules, data from disabled channels is filled with space characters.

There will be no response if the command syntax is incorrect, there is a communication error, or there is no module with the specified address.

Examples:

Command: \$014 Response: ?01
Reads the synchronized data for module 01. An invalid command is returned because the #** command has not been issued in advance.

Command: #** No response
Sends the synchronized sampling command.

Command: \$014 Response: >011+025.56
Reads the synchronized data for module 01. The module returns the synchronized data and sets the status byte to 1 to indicate that this is the first time the synchronized data has been read.

Command: \$014 Response: >010+25.56
Reads the synchronized data for module 01. The module returns the synchronized data and sets the status byte to 0 to indicate that the synchronized data has been read.

Related Commands:

Section 2.2 #**

2.9 \$AA5

Description:

Reads the reset status of a module.

Syntax:

\$AA5[CHKSUM](CR)

\$ Delimiter character
AA Address of the module to be read (00 to FF)
5 Command to read the module reset status

Response:

Valid Command: **!AAS[CHKSUM](CR)**

Invalid Command: **?AA[CHKSUM](CR)**

! Delimiter character for a valid command
? Delimiter character for an invalid command
AA Address of the responding module (00 to FF)
S Reset status of the module
 1: This is the first time the command has been
 sent since the module was powered on.
 0: This is not the first time the command has
 been sent since the module was powered on,
 which denotes that there has been no module
 reset since the last \$AA5 command was sent.

There will be no response if the command syntax is incorrect, there is a communication error, or there is no module with the specified address.

Examples:

Command: \$015

Response: !011

Reads the reset status of module 01. The response shows that it is the first time the \$AA5 command has been sent since the module was powered-on.

Command: \$015

Response: !010

Reads the reset status of module 01. The response shows that there has been no module reset since the last \$AA5 command was sent.

2.10 \$AA5VV

Description:

Specifies the channels to be enabled.

Syntax:

\$AA5VV[CHKSUM](CR)

\$ Delimiter character
AA Address of the module to be set (00 to FF)
5 Command to set the channels to enabled
VV A two-digit hexadecimal value, where bit 0 corresponds to channel 0, bit 1 corresponds to channel 1, etc. When the bit is 1, it denotes that the channel is enabled, and 0 denotes that the channel is disabled.

Response:

Valid Command: **!AA[CHKSUM](CR)**

Invalid Command: **?AA[CHKSUM](CR)**

! Delimiter character for a valid command
? Delimiter character for an invalid command. An invalid command is returned if an attempt is made to enable a channel that is not present.
AA Address of the responding module (00 to FF)

There will be no response if the command syntax is incorrect, there is a communication error, or there is no module with the specified address.

Examples:

Command: \$0153A Response: !01

Enables channels 1, 3, 4, and 5 and disables all other channels of module 01. The module returns a valid response.

Command: \$016 Response: !013A

Reads the channel status of module 01. The module returns a response of 3A, which denotes that channels 1, 3, 4, and 5 are enabled and all other channels are disabled.

Related Commands:

Section 2.11 \$AA6

Notes:

It is recommended that only the channels to be used are enabled.

2.11 \$AA6

Description:

Reads the enabled/disabled status of each channel.

Syntax:

\$AA6[CHKSUM](CR)

\$ Delimiter character
AA Address of the module to be read (00 to FF)
6 Command to read the channel status

Response:

Valid Command: **!AAVV[CHKSUM](CR)**

Invalid Command: **?AA[CHKSUM](CR)**

! Delimiter character for a valid command
? Delimiter character for an invalid command
AA Address of the responding module (00 to FF)
VV A two-digit hexadecimal value, where bit 0 corresponds to channel 0, bit 1 corresponds to channel 1, etc. When the bit is 1, it denotes that the channel is enabled, and 0 denotes that the channel is disabled.

There will be no response if the command syntax is incorrect, there is a communication error, or there is no module with the specified address.

Examples:

Command: \$0153A Response: !01
Enables channels 1, 3, 4, and 5 and disables all other channels of module 01. The module returns a valid response.

Command: \$016 Response: !013A
Reads the channel status of module 01 and returns a response of 3A, which denotes that channels 1, 3, 4, and 5 are enabled and all other channels are disabled.

Related Commands:

Section 2.10 \$AA5VV

2.12 \$AA7CiRrr

Description:

Sets the type code of a channel.

Syntax:

\$AA7CiRrr[CHKSUM](CR)

\$ Delimiter character
AA Address of the module to be set (00 to FF)
7 Command to set the channel range code
Ci i specifies the input channel to be set (0-7)
Rrr rr represents the type code of the channel to be set. Refer to the Temperature Sensor Type Setting table in Section 1.10.

Response:

Valid command: **!AA [CHKSUM](CR)**

Invalid command: **?AA[CHKSUM](CR)**

! Delimiter character for a valid command
? Delimiter character for an invalid command or invalid type code
AA Address of the responding module (00 to FF)

There will be no response if the command syntax is incorrect, there is a communication error, or there is no module with the specified address.

Examples:

- Command: \$017C0R60 Response: !01
Sets the type code for channel 0 of module 01 to be 60 and the module returns a valid response.
- Command: \$027C5R72 Response: !02
Sets the type code for channel 5 of module 02 to be 72 and the module returns a valid response.
- Command: \$037C1R30 Response: ?03
Sets the type code for channel 1 of module 03 to be 30. The module returns an invalid response because the type code is invalid.

Related Commands:

Section 2.13 \$AA8Ci

Related Topics:

Section 1.10 Configuration Tables

Notes:

For the I-7005 and M-7005, when the type code of a channel is changed, the high/low alarms of the channel are disabled.

2.13 \$AA8Ci

Description:

Reads the type code information of a channel.

Syntax:

\$AA8Ci[CHKSUM](CR)

\$	Delimiter character
AA	Address of the module to be read (00 to FF)
8	Command to read the type code of a channel
Ci	Specifies which channel to access for the type code information (i = 0 ~ 7)

Response:

Valid command: **!AA8CiRrr[CHKSUM](CR)**

Invalid command: **?AA[CHKSUM](CR)**

!	Delimiter character for a valid command
?	Delimiter character for an invalid command or invalid channel
AA	Address of the responding module (00 to FF)
Ci	Specifies which input channel the type code information relates to.
Rrr	Represents the type code of the specified input channel. Refer to the Temperature Sensor Type Setting table in Section 1.10.

There will be no response if the command syntax is incorrect, there is a communication error, or there is no module with the specified address.

Examples:

Command: \$018C0

Response: !01C0R70

Reads the input range of channel 0 of module 01 and returns 70.

Related Commands:

Section 2.12 \$AA7CiRrr

Related Topics:

Section 1.10 Configuration Tables

2.14 \$AAB

Description:

Diagnoses the analog inputs for over-range, under-range, and wire opening conditions.

Syntax:

\$AAB[CHKSUM](CR)

\$ Delimiter character

AA Address of the module to be diagnosed (00 to FF)

B Command to diagnose the analog inputs

Response:

Valid command: **!AANN[CHKSUM](CR)**

Invalid command: **?AA[CHKSUM](CR)**

! Delimiter character for a valid command

? Delimiter character for an invalid command

AA Address of the responding module (00 to FF)

NN Represents the diagnostic results of all the analog input channels (00 to FF), where bit 0 corresponds to channel 0, bit 1 corresponds to channel 1, etc. When the bit is 1 it denotes that the channel is enabled and it is in either over-range, under-range or wire opening condition. If the bit is 0 it denotes that the channel is disabled or normal.

There will be no response if the command syntax is incorrect, there is a communication error, or there is no module with the specified address.

Examples:

Command: \$01B

Response: !0101

Diagnoses the analog inputs of module 01. The module returns a valid response denoting that channel 1 is in either over-range, under-range or wire opening condition.

2.15 \$AAF

Description:

Reads the firmware version of a module.

Syntax:

\$AAF[CHKSUM](CR)

\$ Delimiter character

AA Address of the module to be read (00 to FF)

F Command to read the firmware version

Response:

Valid command: **!AA(Data)[CHKSUM](CR)**

Invalid command: **?AA[CHKSUM](CR)**

! Delimiter character for a valid command

? Delimiter character for an invalid command

AA Address of the responding module (00 to FF)

(Data) Firmware version string of the module

There will be no response if the command syntax is incorrect, there is a communication error, or there is no module with the specified address.

Examples:

Command: \$01F

Response: !01A2.0

Reads the firmware version of module 01, and shows that it is version A2.0.

Command: \$02F

Response: !02B1.1

Reads the firmware version of module 02, and shows that it is version B1.1.

2.16 \$AAI

Description:

Reads the INIT status of a module.

Syntax:

\$AAI[CHKSUM](CR)

\$ Delimiter character

AA Address of the module to be diagnosed (00 to FF)

I Command to read the module INIT status

Response:

Valid command: **!AAS[CHKSUM](CR)**

Invalid command: **?AA[CHKSUM](CR)**

! Delimiter character for a valid command

? Delimiter character for an invalid command

AA Address of the responding module (00 to FF)

S INIT switch status of the module

0: The INIT switch is moved to the INIT position

1: The INIT switch is moved to the Normal position

There will be no response if the command syntax is incorrect, there is a communication error, or there is no module with the specified address.

Examples:

Command: \$01I

Response: !010

Reads the INIT status of module 01. The response shows that the INIT switch is moved to the INIT position.

2.17 \$AAM

Description:

Reads the name of a module.

Syntax:

\$AAM[CHKSUM](CR)

\$ Delimiter character

AA Address of the module to be read (00 to FF)

M Command to read the module name

Response:

Valid command: **!AA(Data)[CHKSUM](CR)**

Invalid command: **?AA[CHKSUM](CR)**

! Delimiter character for a valid command

? Delimiter character for an invalid command

AA Address of the responding module (00 to FF)

(Name) Name string of the module

There will be no response if the command syntax is incorrect, there is a communication error, or there is no module with the specified address.

Examples:

Command: \$01M

Response: !017005

Reads the module name of module 01 and returns the name "7005".

Related Commands:

Section 2.26 ~AAO(Name)

2.18 \$AAP

Description:

Reads the communication protocol information.

Syntax:

\$AAP[CHKSUM](CR)

\$ Delimiter character

AA Address of the module to be read (00 to FF)

P Command to read the communication protocol

Response:

Valid Response: !AASC[CHKSUM](CR)

Invalid Response: ?AA[CHKSUM](CR)

! Delimiter character for a valid response

? Delimiter character for an invalid response

AA Address of the responding module (00 to FF)

S The protocols supported by the module

0: only DCON protocol is supported

1: both the DCON and Modbus RTU protocols
are supported

C Current protocol saved in EEPROM that will be
used at the next power on reset

0: the protocol set in EEPROM is DCON

1: the protocol set in EEPROM is Modbus RTU

There will be no response if the command syntax is incorrect, there is a communication error, or there is no module with the specified address.

Examples:

Command: \$01P

Response: !0110

Reads the communication protocol of module 01 and returns a response of 10 meaning that it supports both the DCON and Modbus RTU protocols and the protocol that will be used at the next power on reset is DCON.

Related Commands:

Section 2.19 \$AAPN

Note:

This command is only applicable to the M-7005.

2.19 \$AAPN

Description:

Sets the communication protocol.

Syntax:

\$AAPN[CHKSUM](CR)

\$ Delimiter character

AA Address of the module to be read (00 to FF)

P Command to set the communication protocol

N 0: DCON protocol

1: Modbus RTU protocol

Before using this command, the rear slide switch must be in the INIT position for M-7005, see Section A.1 for details. The new protocol is saved in the EEPROM and will be effective after the next power on reset.

Response:

Valid Response: !AA[CHKSUM](CR)

Invalid Response: ?AA[CHKSUM](CR)

! Delimiter character for a valid response

? Delimiter character for an invalid response

AA Address of the responding module (00 to FF)

There will be no response if the command syntax is incorrect, there is a communication error, or there is no module with the specified address.

Examples:

Command: \$01P1

Response: ?01

Sets the communication protocol of module 01 to Modbus RTU and returns an invalid response because the module is not in INIT mode.

Command: \$01P1

Response: !01

Sets the communication protocol of module 01 to Modbus RTU and returns a valid response.

Related Commands:

Section 2.18 \$AAP

Related Topics:

Section A.1 INIT Mode

Note:

This command is only applicable to the M-7005.

2.20 \$AAS0

Description:

Performs an internal calibration on a module.

Syntax:

\$AAS0[CHKSUM](CR)

\$ Delimiter character

AA Address of the module to be calibrated (00 to FF)

S0 Command to perform the internal calibration

Response:

Valid command: **!AA[CHKSUM](CR)**

Invalid command: **?AA[CHKSUM](CR)**

! Delimiter character for a valid command

? Delimiter character for an invalid command

AA Address of the responding module (00 to FF)

There will be no response if the command syntax is incorrect, there is a communication error, or there is no module with the specified address.

Examples:

Command: \$01S0

Response: !01

Sends the command to perform an internal calibration on module 01 and returns a valid response.

Related Commands:

Section 2.21 \$AAS1

2.21 \$AAS1

Description:

Reloads the factory default calibration parameters, including the internal calibration parameters.

Syntax:

\$AAS1[CHKSUM](CR)

- \$ Delimiter character
AA Address of the module to have the default parameters reloaded (00 to FF)
S1 Command to reload the factory default calibration parameters

Response:

Valid command: **!AA[CHKSUM](CR)**

Invalid command: **?AA[CHKSUM](CR)**

- ! Delimiter character for a valid command
? Delimiter character for an invalid command
AA Address of the responding module (00 to FF)

There will be no response if the command syntax is incorrect, there is a communication error, or there is no module with the specified address.

Examples:

Command: \$01S1

Response: !01

Sends the command to reload the factory default calibration parameters for module 01 and returns a valid response.

Related Commands:

Section 2.20 \$AAS0

Related Topics:

Section 1.9 Calibration

2.22 ~AAD

Description:

Reads the temperature scale information of a module.

Syntax:

~AAD[CHKSUM](CR)

~ Delimiter character

AA Address of the module to be read (00 to FF)

D Command to read the temperature scale

Response:

Valid Command: **!AAT[CHKSUM](CR)**

Invalid Command: **?AA[CHKSUM](CR)**

! Delimiter character for a valid command

? Delimiter character for an invalid command

AA Address of the responding module (00 to FF)

T Temperature scale

0: the temperature scale is Celsius.

1: the temperature scale is Fahrenheit.

There will be no response if the command syntax is incorrect, there is a communication error, or there is no module with the specified address.

Examples:

Command: ~01D Response: !010
 Reads the temperature scale of module 01 and
 returns Celsius.

Command: ~02D Response: !021
 Reads the temperature scale of module 02 and
 returns Fahrenheit.

Related Commands:

Section 2.23 ~AADT

Notes:

The default temperature scale is Celsius.

2.23 ~AADT

Description:

Sets the temperature scale of a module to Celsius or Fahrenheit.

Syntax:

~AADT[CHKSUM](CR)

- ~ Delimiter character
- AA Address of the module to be set (00 to FF)
- D Command to set the temperature scale
- T C: set the temperature scale to Celsius.
F: set the temperature scale to Fahrenheit.

Response:

Valid Command: **!AA[CHKSUM](CR)**

Invalid Command: **?AA[CHKSUM](CR)**

- ! Delimiter character for a valid command
- ? Delimiter character for an invalid command
- AA Address of the responding module (00 to FF)

There will be no response if the command syntax is incorrect, there is a communication error, or there is no module with the specified address.

Examples:

Command: ~01DC

Response: !01

Sets the temperature scale of module 01 to Celsius,
and returns a valid response.

Command: ~02DF

Response: !02

Sets the temperature scale of module 02 to
Fahrenheit, and returns a valid response.

Related Commands:

Section 2.22 ~AAD

Notes:

1. The default temperature scale is Celsius.
2. The commands affected are #AA, #AAN,
@AARTTttR(Data), @AAHI(data)CiTOj,
@AALO(data)CiTOj.

2.24 ~AAEV

Description:

Enables/Disables the module calibration.

Syntax:

~AAEV[CHKSUM](CR)

- ~ Delimiter character
- AA Address of the module to be enabled/disabled (00 to FF)
- E Command to enable/disable calibration
- V 1: enable calibration
0: disable calibration

Response:

Valid Command: **!AA[CHKSUM](CR)**

Invalid Command: **?AA[CHKSUM](CR)**

- ! Delimiter character for a valid command
- ? Delimiter character for an invalid command
- AA Address of the responding module (00 to FF)

There will be no response if the command syntax is incorrect, there is a communication error, or there is no module with the specified address.

Examples:

Command: \$010

Response: ?01

Sends the command to perform a span calibration on module 01. An invalid response is returned because the “enable calibration” command has not yet been sent.

Command: ~01E1

Response: !01

Enables calibration on module 01 and returns a valid response.

Command: \$010

Response: !01

Sends the command to perform a span calibration on module 01 and returns a valid response.

Related Commands:

Section 2.5 \$AA0Ci, Section 2.6 \$AA1Ci

Related Topics:

Section 1.9 Calibration

2.25 ~AAI (Soft INIT command)

Description:

The Soft INIT command is used to enable modification of the Baud Rate and checksum settings using software only.

Syntax:

~AAI[CHKSUM](CR)

~ Delimiter character
AA Address of the module to be set (00 to FF)
I Command to set the Soft INIT

Response:

Valid command: **!AA[CHKSUM](CR)**
Invalid command: **?AA[CHKSUM](CR)**
! Delimiter character for a valid command
? Delimiter character for an invalid command
AA Address of the responding module (00 to FF)

There will be no response if the command syntax is incorrect, there is a communication error, or there is no module with the specified address.

Examples:

Command: ~01I Response: !01
 Sets the soft INIT of module 01 and returns a valid response.

Related Commands:

Section 2.1 %AANNTCCFF, Section 2.27 ~AATnn

Related Topics:

Section A.1 INIT* Pin Operation

Notes:

The ~AATnn command should be sent prior to sending this command, see Section 2.27 for details.

2.26 ~AAO(Name)

Description:

Sets the name of a module.

Syntax:

~AAO(Name)[CHKSUM](CR)

- ~ Delimiter character
- AA Address of the module to be set (00 to FF)
- O Command to set the module name
- (Name) New name of the module (max. 6 characters).

Response:

Valid command: **!AA[CHKSUM](CR)**

Invalid command: **?AA[CHKSUM](CR)**

- ! Delimiter character for a valid command
- ? Delimiter character for an invalid command
- AA Address of the responding module (00 to FF)

There will be no response if the command syntax is incorrect, there is a communication error, or there is no module with the specified address.

Examples:

Command: ~01O7005N Response: !01
Sets the name of module 01 to be “7005N” and
returns a valid response.

Command: \$01M Response: !017005N
Reads the name of module 01 and returns the name
“7005N”.

Related Commands:

Section 2.17 \$AAM

2.27 ~AATnn

Description:

Sets the soft INIT timeout value.

Syntax:

~AATnn[CHKSUM](CR)

- ~ Delimiter character
- AA Address of the module to be set (00 to FF)
- T Command to set the soft INIT timeout
- nn Two hexadecimal digits representing the timeout value in seconds. The maximum timeout value is 60 seconds. When changing the Baud Rate or checksum settings without altering the INIT* status, the ~AAI and %AANNTTCCFF commands should be sent consecutively and the time interval between the two commands should be less than the soft INIT timeout. If the soft INIT timeout is 0, then the Baud Rate and checksum settings cannot be changed using software only. The power-on reset value of the soft INIT timeout is 0.

Response:

Valid command: **!AA[CHKSUM](CR)**

Invalid command: **?AA[CHKSUM](CR)**

! Delimiter character for a valid command

? Delimiter character for an invalid command

AA Address of the responding module (00 to FF)

There will be no response if the command syntax is incorrect, there is a communication error, or there is no module with the specified address.

Examples:

Command: ~01I

Response: !01

Sets the soft INIT timeout value of module 01 and returns a valid response.

Command: %0101000700

Response: ?01

Attempts to change the Baud Rate of module 01 to 19200 without first altering the INIT * status. The module returns an invalid response because the soft INIT timeout value is 0.

Command: ~01T10

Response: !01

Sets the soft INIT timeout value of module 01 to 16 seconds and returns a valid response.

Command: ~01I

Response: !01

Sets the soft INIT of module 01 and returns a valid response.

Command: %0101000700

Response: !01

Changes the Baud Rate of module 01 to 19200 without first altering INIT * status. The module returns a valid response.

Related Commands:

Section 2.1 %AANNTTCCFF, Section 2.25 ~AAI

Related Topics:

Section A.1 INIT* Pin Operation

Notes:

It is recommended that the soft INIT timeout value is reset to 0 once any changes to the Baud Rate and checksum settings have been completed.

2.28 @AAGxTtt

Description:

Reads the Steinhart coefficient of a user-defined type.

Syntax:

@AAGxTtt[CHKSUM](CR)

@	Delimiter character
AA	Address of the module to be read (00 to FF)
G	Command to read the Steinhart coefficient
x	A: reads Steinhart coefficient A B: reads Steinhart coefficient B C: reads Steinhart coefficient C
Ttt	tt represents the type code of the user-defined type to read the Steinhart coefficient.

Response:

Valid command: **!AA(Data)[CHKSUM](CR)**

Invalid command: **?AA[CHKSUM](CR)**

!	Delimiter character for a valid command
?	Delimiter character for an invalid command or invalid type code
AA	Address of the responding module (00 to FF)
(Data)	Eight hexadecimal digits to represent the Steinhart coefficient in IEEE-754 format. See Section 1.11 for details.

There will be no response if the command syntax is incorrect, there is a communication error, or there is no module with the specified address.

Examples:

Command: @01GAT70 Response: !013A94030A
Reads the A coefficient of type 70 of module 01 and returns a value of 3A94030A, which is equivalent to 1.129241×10^{-3} .

Command: @01GBT70 Response: !0139757ACF
Reads the B coefficient of type 70 of module 01 and returns a value of 39757ACF, which is equivalent to 2.341077×10^{-4} .

Command: @01GCT70 Response: !0133BC73A5
Reads the C coefficient of type 70 of module 01 and returns a value of 33BC73A5, which is equivalent to 8.775468×10^{-8} .

Related Commands:

Section 2.29 @AARTTttR(data), Section 2.30
@AASxTttC(data)

Related Topics:

Section 1.11 User-defined Types, Section A.6 Thermistor

2.29 @AARTTttR(Data)

Description:

Reads the temperature associated with the input resistance of a user-defined type.

Syntax:

@AARTTttR(Data)[CHKSUM](CR)

- @ Delimiter character
- AA Address of the module to be read (00 to FF)
- RT Command to read the temperature associated with the input resistance of a user-defined type
- Ttt tt represents the type code of the user-defined type.
- R(Data) The (Data) consists of seven decimal digits, or five digits, decimal point and one additional digit, to represent the input resistance.

Response:

Valid command: **!AA(Data)[CHKSUM](CR)**

Invalid command: **?AA[CHKSUM](CR)**

- ! Delimiter character for a valid command
- ? Delimiter character for an invalid command or invalid type code
- AA Address of the responding module (00 to FF)
- (Data) The (Data) consists of a +/- sign, three digits, decimal point and two additional digits to represent the temperature associated with the input resistance.

There will be no response if the command syntax is incorrect, there is a communication error, or there is no module with the specified address.

Examples:

Command: @01RTT70R0104500

Response: !01-032.64

Reads the temperature associated with 104500 ohms of type 70 of module 01, and the module returns a value of -32.64 degree.

Command: @01RTT70R00801.2

Response: !01+072.62

Reads the temperature associated with 801.2 ohms of type 70 of module 01, and the module returns a value of 72.62 degree.

Related Commands:

Section 2.22 ~AAD, Section 2.23 ~AADT, Section 2.28 @AAGxTtt, Section 2.30 @AASxTttC(data)

Related Topics:

Section A.6 Thermistor

Notes:

The temperature scale is set using the ~AADT command and can be read using the ~AAD command. See Sections 2.22 and 2.23 for details.

2.30 @AASxTttC(data)

Description:

Sets the Steinhart coefficient of a user-defined type.

Syntax:

@AASxTttC(data)[CHKSUM](CR)

- @ Delimiter character
- AA Address of the module to be set (00 to FF)
- S Command to set the Steinhart coefficient
- x A: sets Steinhart coefficient A
B: sets Steinhart coefficient B
C: sets Steinhart coefficient C
- Ttt tt represents the type code of the user-defined type to set the Steinhart coefficient.
- C(Data) The (Data) is eight hexadecimal digits in IEEE-754 format to represent the Steinhart coefficient. See Section 1.11 for details.

Response:

Valid command: **!AA[CHKSUM](CR)**

Invalid command: **?AA[CHKSUM](CR)**

- ! Delimiter character for a valid command
- ? Delimiter character for an invalid command or invalid type code
- AA Address of the responding module (00 to FF)

There will be no response if the command syntax is incorrect, there is a communication error, or there is no module with the specified address.

Examples:

Command: @01SAT70C3A94030A Response: !01
Sets the A coefficient of type 70 of module 01 to be 3A94030A, which is equivalent to 1.129241×10^{-3} , and the module returns a valid response.

Command: @01SBT70C39757ACF Response: !01
Sets the B coefficient of type 70 of module 01 to be 39757ACF, which is equivalent to 2.341077×10^{-4} , and the module returns a valid response.

Command: @01SCT70C33BC73A5 Response: !01
Sets the C coefficient of type 70 of module 01 to be 33BC73A5, which is equivalent to 8.775468×10^{-8} , and the module returns a valid response.

Related Commands:

Section 2.28 @AAGxTtt, Section 2.29 @AARTTttR(data)

Related Topics:

Section 1.11 User-defined Types, Section A.6 Thermistor

Notes:

If the resistance versus temperature data table of the thermistor is available, it is suggested that the @AARTTttR(data) command be used to verify the accuracy of the user-defined type.

2.31 @AACHCi

Description:

Clears the high latched alarm of a channel.

Syntax:

@AACHCi[CHKSUM](CR)

@ Delimiter character
AA Address of the module to be set (00 to FF)
CH Command to clear the high latched alarm
Ci i represents which channel should have the high latched alarm cleared.

Response:

Valid command: **!AA(Data)[CHKSUM](CR)**

Invalid command: **?AA[CHKSUM](CR)**

! Delimiter character for a valid command
? Delimiter character for an invalid command or invalid channel
AA Address of the responding module (00 to FF)

There will be no response if the command syntax is incorrect, there is a communication error, or there is no module with the specified address.

Examples:

Command: @01CHC2 Response: !01

Clears the high latched alarm of channel 2 of module 01, and the module returns a valid response.

Related Commands:

Section 2.32 @AACLCi, Section 2.33 @AADHCi,

Section 2.35 @AADLCi, Section 2.37

@AAHI(data)CiTOj, Section 2.38 @AALO(data)CiTOj

Related Topics:

Section 1.12 Digital Outputs and Alarms

2.32 @AACLCi

Description:

Clears the low latched alarm of a channel.

Syntax:

@AACLCi[CHKSUM](CR)

- @ Delimiter character
- AA Address of the module to be set (00 to FF)
- CL Command to clear the low latched alarm
- Ci i represents which channel should have the low latched alarm cleared.

Response:

Valid command: **!AA(Data) [CHKSUM](CR)**

Invalid command: **?AA[CHKSUM](CR)**

- ! Delimiter character for a valid command
- ? Delimiter character for an invalid command or invalid channel
- AA Address of the responding module (00 to FF)

There will be no response if the command syntax is incorrect, there is a communication error, or there is no module with the specified address.

Examples:

Command: @01CLC2 Response: !01

Clears the low latched alarm of channel 2 of module 01, and the module returns a valid response.

Related Commands:

Section 2.31 @AACHCi, Section 2.33 @AADHCi,

Section 2.35 @AADLCi, Section 2.37

@AAHI(data)CiTOj, Section 2.38 @AALO(data)CiTOj

Related Topics:

Section 1.12 Digital Outputs and Alarms

2.33 @AADHci

Description:

Disables the high alarm of a channel.

Syntax:

@AADHci[CHKSUM](CR)

- @ Delimiter character
- AA Address of the module to be set (00 to FF)
- DH Command to disable the high alarm
- Ci i represents which channel should have the high alarm disabled.

Response:

Valid command: **!AA(Data)[CHKSUM](CR)**

Invalid command: **?AA[CHKSUM](CR)**

- ! Delimiter character for a valid command
- ? Delimiter character for an invalid command or invalid channel
- AA Address of the responding module (00 to FF)

There will be no response if the command syntax is incorrect, there is a communication error, or there is no module with the specified address.

Examples:

Command: @01DHC2 Response: !01

Disables the high alarm of channel 2 of module 01,
and the module returns a valid response.

Related Commands:

Section 2.31 @AACHCi, Section 2.32 @AACLCi,

Section 2.35 @AADLCi, Section 2.37

@AAHI(data)CiTOj, Section 2.38 @AALO(data)CiTOj

Related Topics:

Section 1.12 Digital Outputs and Alarms

2.34 @AADI

Description:

Reads the status of the digital output ports.

Syntax:

@AADI[CHKSUM](CR)

- @ Delimiter character
- AA Address of the module to be read (00 to FF)
- DI Command to read the digital output ports

Response:

Valid command: **!AAOO[CHKSUM](CR)**

Invalid command: **?AA[CHKSUM](CR)**

- ! Delimiter character for a valid command
- ? Delimiter character for an invalid command
- AA Address of the responding module (00 to FF)
- OO A two-digit hexadecimal value, where bit 0 corresponds to DO0, bit 1 corresponds to DO1, etc. When the bit is 1, it denotes that the digital output port is on, and 0 denotes that the digital output port is off.

There will be no response if the command syntax is incorrect, there is a communication error, or there is no module with the specified address.

Examples:

Command: @01DI Response: !0133

Reads the digital output port status of module 01 and returns 33h, which denotes that DO0, DO1, DO4 and DO5 are on and DO2 and DO3 are off.

Related Commands:

Section 2.36 @AADODD

Related Topics:

Section 1.12 Digital Outputs and Alarms

2.35 @AADLCi

Description:

Disables the low alarm of a channel.

Syntax:

@AADHCi[CHKSUM](CR)

- @ Delimiter character
- AA Address of the module to be set (00 to FF)
- DL Command to disable the low alarm
- Ci i represents which channel should have the low alarm disabled.

Response:

Valid command: **!AA(Data)[CHKSUM](CR)**

Invalid command: **?AA[CHKSUM](CR)**

- ! Delimiter character for a valid command
- ? Delimiter character for an invalid command or invalid channel
- AA Address of the responding module (00 to FF)

There will be no response if the command syntax is incorrect, there is a communication error, or there is no module with the specified address.

Examples:

Command: @01DLC2 Response: !01

Disables the low alarm of channel 2 of module 01,
and the module returns a valid response.

Related Commands:

Section 2.31 @AACHCi, Section 2.32 @AACLCi,

Section 2.33 @AADHCi, Section 2.37

@AAHI(data)CiTOj, Section 2.38 @AALO(data)CiTOj

Related Topics:

Section 1.12 Digital Outputs and Alarms

2.36 @AADODD

Description:

Sets the digital output ports.

Syntax:

@AADODD[CHKSUM](CR)

@	Delimiter character
AA	Address of the module to be set (00 to FF)
DO	Command to set the digital output ports
DD	A two-digit hexadecimal value, where bit 0 corresponds to DO0, bit 1 corresponds to DO1, etc. When the bit is 1, it denotes that the digital output port is on, and 0 denotes that the digital output port is off.

Response:

Valid command: **!AA[CHKSUM](CR)**

Invalid command: **?AA[CHKSUM](CR)**

!	Delimiter character for a valid command
?	Delimiter character for an invalid command
AA	Address of the responding module (00 to FF)

There will be no response if the command syntax is incorrect, there is a communication error, or there is no module with the specified address.

Examples:

Command: @01DO33 Response: !01

Sets DO0 to on, DO1 to on, DO2 to off, DO3 to off, DO4 to on, and DO5 to on, and the module returns a valid response.

Related Commands:

Section 2.34 @AADI

Related Topics:

Section 1.12 Digital Outputs and Alarms

Notes:

1. If the digital output port is already set to be an alarm output port, then the value written to the port is ignored.
2. When a host watchdog timeout occurs, the module will respond with an invalid command for this command and the DO value that was sent is ignored.

2.37 @AAHI(data)CiTOj

Description:

Sets the high alarm of a channel.

Syntax:

@AAHI(data)CiTOj[CHKSUM](CR)

- @ Delimiter character
- AA Address of the module to be set (00 to FF)
- HI Command to set the high alarm
- (data) High alarm limit, which consists of a sign, three digits, a decimal point and two additional digits.
- Ci i represents which channel is to be checked for the high alarm.
- T Alarm type:
 - M: momentary alarm
 - L: latched alarm
- Oj j specifies the digital output port to be used for the alarm output.

Response:

Valid command: **!AA[CHKSUM](CR)**

Invalid command: **?AA[CHKSUM](CR)**

- ! Delimiter character for a valid command
- ? Delimiter character for an invalid command or invalid channel
- AA Address of the responding module (00 to FF)

There will be no response if the command syntax is incorrect, there is a communication error, or there is no module with the specified address.

Examples:

Command: @01HI+090.00C0MO1 Response: !01
Sets the high alarm of channel 0 of module 01. The alarm limit is 90.0 degree. The alarm type is momentary. The alarm output port is DO1.

Command: @01HI+110.00C3LO5 Response: !01
Sets the high alarm of channel 3 of module 01. The alarm limit is 110.0 degree. The alarm type is latched. The alarm output port is DO5.

Related Commands:

Section 2.22 ~AAD, Section 2.23 ~AADT, Section 2.31 @AACHCi, Section 2.32 @AACLCi, Section 2.33 @AADHCi, Section 2.38 @AALO(data)CiTOj

Related Topics:

Section 1.12 Digital Outputs and Alarms

Notes:

1. The temperature scale of the temperature limit is set using the ~AADT command and can be read using the ~AAD command. See Sections 2.22 and 2.23 for details. If the temperature scale is changed, then the temperature limit should be changed accordingly. The default temperature scale is Celsius.
2. It is possible to have more than one alarm associated with a digital output port. The digital output port is turned on when one of the alarms is activated, and is turned off when all of the alarms associated are not activated.

2.38 @AALO(data)CiTOj

Description:

Sets the low alarm of a channel.

Syntax:

@AALO(data)CiTOj[CHKSUM](CR)

- @ Delimiter character
- AA Address of the module to be set (00 to FF)
- LO Command to set the low alarm
- (data) Low alarm limit, which consists of a sign, three digits, a decimal point and two additional digits.
- Ci i represents which channel is to be checked for the low alarm.
- T Alarm type:
 - M: momentary alarm
 - L: latched alarm
- Oj j specifies the digital output port to be used for the alarm output.

Response:

Valid command: **!AA[CHKSUM](CR)**

Invalid command: **?AA[CHKSUM](CR)**

- ! Delimiter character for a valid command
- ? Delimiter character for an invalid command or invalid channel
- AA Address of the responding module (00 to FF)

There will be no response if the command syntax is incorrect, there is a communication error, or there is no module with the specified address.

Examples:

Command: @01LO-005.00C0MO1 Response: !01
Sets the low alarm of channel 0 of module 01. The alarm limit is -5.0 degree. The alarm type is momentary. The alarm output port is DO1.

Command: @01LO+010.00C3LO5 Response: !01
Sets the low alarm of channel 3 of module 01. The alarm limit is 10.0 degree. The alarm type is latched. The alarm output port is DO5.

Related Commands:

Section 2.22 ~AAD, Section 2.23 ~AADT, Section 2.31 @AACHCi, Section 2.32 @AACLCi, Section 2.33 @AADHCi, Section 2.37 @AAHI(data)CiTOj

Related Topics:

Section 1.12 Digital Outputs and Alarms

Notes:

1. The temperature scale of the temperature limit is set using the ~AADT command and can be read using the ~AAD command. See Sections 2.22 and 2.23 for details. If the temperature scale is changed, then the temperature limit should be changed accordingly. The default temperature scale is Celsius.
2. It is possible to have more than one alarm associated with a digital output port. The digital output port is turned on when one of the alarms is activated, and is turned off when all of the alarms associated are not activated.

2.39 @AARAOj

Description:

Reads the currently activated alarms associated with a digital output port.

Syntax:

@AARAOj[CHKSUM](CR)

- @ Delimiter character
- AA Address of the module to be read (00 to FF)
- RA Command to read the currently activated alarms associated with a digital output port.
- Oj j specifies the digital output port.

Response:

Valid command: **!AAHLL[CHKSUM](CR)**

Invalid command: **?AA[CHKSUM](CR)**

- ! Delimiter character for a valid command
- ? Delimiter character for an invalid command or invalid port
- AA Address of the responding module (00 to FF)
- HH A two-digit hexadecimal value to represent the currently activated high alarms associated with the digital output port, where bit 0 corresponds to channel 0, bit 1 corresponds to channel 1, etc. When the bit is 1, it denotes that there is an activated high alarm associated with the channel. When the bit is 0, it denotes that there are no activated high alarms associated with the channel.

LL A two-digit hexadecimal value to represent the currently activated low alarms associated with the digital output port, where bit 0 corresponds to channel 0, bit 1 corresponds to channel 1, etc. When the bit is 1, it denotes that there is an activated low alarm associated with the channel. When the bit is 0, it denotes that there are no activated low alarms associated with the channel.

There will be no response if the command syntax is incorrect, there is a communication error, or there is no module with the specified address.

Examples:

Command: @01RAO1 Response: !011122
Reads the currently activated alarms associated with the DO1 of module 01. The module responds with 1122, which denotes that there is an activated high alarm associated with channels 0 and 4, and an activated low alarm associated with channels 1 and 5.

Related Commands:

Section 2.42 @AAROOj

Related Topics:

Section 1.12 Digital Outputs and Alarms

2.40 @AARHCi

Description:

Reads the high alarm settings of a channel.

Syntax:

@AARHCi[CHKSUM](CR)

@	Delimiter character
AA	Address of the module to be read (00 to FF)
RH	Command to read the high alarm settings.
Ci	i represents from which channel the high alarm settings should be read.

Response:

Valid command: **!AA(Data)SOj[CHKSUM](CR)**

Invalid command: **?AA[CHKSUM](CR)**

!	Delimiter character for a valid command
?	Delimiter character for an invalid command or invalid channel
AA	Address of the responding module (00 to FF)
(data)	High alarm limit, which consists of a (+/-) sign, three digits, a decimal point and two additional digits.
S	Alarm type: 0: alarm disabled 1: momentary alarm 2: latched alarm
Oj	j specifies the digital output port to be used for the alarm output.

There will be no response if the command syntax is incorrect, there is a communication error, or there is no module with the specified address.

Examples:

Command: @01RHC0 Response: !01+090.001O1
Reads the high alarm settings of channel 0 of module 01. The module responds that the high alarm limit is 90.0 degree, the alarm type is momentary and the alarm output port is DO1.

Command: @01RHC3 Response: !01+110.002O5
Reads the high alarm settings of channel 3 of module 01. The module responds that the high alarm limit is 110.0 degree, the alarm type is latched and the alarm output port is DO5.

Related Commands:

Section 2.31 @AACHCi, Section 2.32 @AACLCi,
Section 2.33 @AADHCi, Section 2.37
@AAHI(data)CiTOj, Section 2.41 @AARLCi

Related Topics:

Section 1.12 Digital Outputs and Alarms

Notes:

The temperature scale of the temperature limit can be read using the ~AAD command. The default temperature scale is Celsius. See Section 2.22 for details.

2.41 @AARLCi

Description:

Reads the low alarm setting of a channel.

Syntax:

@AARLCi[CHKSUM](CR)

- @ Delimiter character
- AA Address of the module to be read (00 to FF)
- RL Command to read the low alarm setting.
- Ci i represents from which channel the low alarm setting should be read.

Response:

Valid command: **!AA(Data)SOj[CHKSUM](CR)**

Invalid command: **?AA[CHKSUM](CR)**

- ! Delimiter character for a valid command
- ? Delimiter character for an invalid command or invalid channel
- AA Address of the responding module (00 to FF)
- (data) Low alarm limit which consists of a (+/-) sign, three digits, a decimal point and two additional digits.
- S Alarm type:
 - 0: alarm disabled
 - 1: momentary alarm
 - 2: latched alarm
- Oj j specifies the digital output port to be used for the alarm output.

There will be no response if the command syntax is incorrect, there is a communication error, or there is no module with the specified address.

Examples:

Command: @01RLC0 Response: !01+010.001O1
Reads the low alarm setting of channel 0 of module 01. The module responds that the low alarm limit is 10.0 degree, the alarm type is momentary and the alarm output port is DO1.

Command: @01RLC3 Response: !01-020.002O5
Reads the low alarm setting of channel 3 of module 01. The module responds that the low alarm limit is -20.0 degree, the alarm type is latched and the alarm output port is DO5.

Related Commands:

Section 2.31 @AACHCi, Section 2.32 @AACLCi,
Section 2.33 @AADHCi, Section 2.38
@AALO(data)CiTOj, Section 2.40 @AARHCi

Related Topics:

Section 1.12 Digital Outputs and Alarms

Notes:

The temperature scale of the temperature limit can be read using the ~AAD command. The default temperature scale is Celsius. See Section 2.22 for details.

2.42 @AAROOj

Description:

Reads the alarms associated with a digital output port.

Syntax:

@AARAOj[CHKSUM](CR)

- @ Delimiter character
- AA Address of the module to be read (00 to FF)
- RO Command to read the alarms associated with a digital output port.
- Oj j specifies the digital output port.

Response:

Valid command: **!AAHLL[CHKSUM](CR)**

Invalid command: **?AA[CHKSUM](CR)**

- ! Delimiter character for a valid command
- ? Delimiter character for an invalid command or invalid port
- AA Address of the responding module (00 to FF)
- HH A two-digit hexadecimal value to represent the high alarms associated with the digital output port, where bit 0 corresponds to channel 0, bit 1 corresponds to channel 1, etc. When the bit is 1, it denotes that the high alarm of the channel is set. When the bit is 0, it denotes that the high alarm of the channel is disabled.

LL A two-digit hexadecimal value to represent the low alarms associated with the digital output port, where bit 0 corresponds to channel 0, bit 1 corresponds to channel 1, etc. When the bit is 1, it denotes that the low alarm of the channel is set. When the bit is 0, it denotes that the low alarm of the channel is disabled.

There will be no response if the command syntax is incorrect, there is a communication error, or there is no module with the specified address.

Examples:

Command: @01ROO1 Response: !011122
Reads the alarms associated with the DO1 of module 01. The module responds with 1122 meaning that the high alarms on channels 0 and 4 and the low alarms on channels 1 and 5 are associated with the DO1.

Related Commands:

Section 2.39 @AARAOj

Related Topics:

Section 1.12 Digital Outputs and Alarms

2.43 ~**

Description:

Informs all modules that the host is OK.

Syntax:

~**[CHKSUM](CR)

~ Delimiter character

** Host OK command

Response:

No response.

Examples:

Command: ~**	No response
Sends a "Host OK" command to all modules.	

Related Commands:

Section 2.44 ~AA0, Section 2.45 ~AA1, Section 2.46 ~AA2, Section 2.47 ~AA3EVR, Section 2.48 ~AA4, Section 2.49 ~AA5PPSS

Related Topics:

Section A.2 Dual Watchdog Operation

2.44 ~AA0

Description:

Reads the host watchdog status of a module.

Syntax:

~AA0[CHKSUM](CR)

- ~ Delimiter character
- AA Address of the module to be read (00 to FF)
- 0 Command to read the module status

Response:

Valid command: **!AASS[CHKSUM](CR)**

Invalid command: **?AA[CHKSUM](CR)**

- ! Delimiter character for a valid command
- ? Delimiter character for an invalid command
- AA Address of the responding module (00 to FF)
- SS Two hexadecimal digits that represent the host watchdog status, where:
 - Bit 7: 0 indicates that the host watchdog is disabled, and 1 indicates that the host watchdog is enabled,
 - Bit 2: 1 indicates that a host watchdog timeout has occurred, and 0 indicates that no host watchdog timeout has occurred.The host watchdog status is stored in EEPROM and can only be reset by using the ~AA1 command.

There will be no response if the command syntax is incorrect, there is a communication error, or there is no module with the specified address.

Examples:

Command: ~010

Response: !0100

Reads the host watchdog status of module 01 and returns 00, meaning that the host watchdog is disabled and no host watchdog timeout has occurred.

Command: ~020

Response: !0204

Reads the host watchdog status of module 02 and returns 04, meaning that a host watchdog timeout has occurred.

Related Commands:

Section 2.43 ~**, Section 2.45 ~AA1, Section 2.46 ~AA2, Sec 2.47 ~AA3Evv, Section 2.48 ~AA4, Section 2.49 ~AA5PPSS

Related Topics:

Section A.2 Dual Watchdog Operation

2.45 ~AA1

Description:

Resets the host watchdog timeout status of a module.

Syntax:

~AA1[CHKSUM](CR)

- ~ Delimiter character
- AA Address of the module to be reset (00 to FF)
- 1 Command to reset the host watchdog timeout status

Response:

Valid command: **!AA[CHKSUM](CR)**

Invalid command: **?AA[CHKSUM](CR)**

- ! Delimiter character for a valid command
- ? Delimiter character for an invalid command
- AA Address of the responding module (00 to FF)

There will be no response if the command syntax is incorrect, there is a communication error, or there is no module with the specified address.

Examples:

Command: ~010

Response: !0104

Reads the host watchdog status of module 01 and shows that a host watchdog timeout has occurred.

Command: ~011

Response: !01

Resets the host watchdog timeout status of module 01 and returns a valid response.

Command: ~010

Response: !0100

Reads the host watchdog status of module 01 and shows that no host watchdog timeout has occurred.

Related Commands:

Section 2.43 ~**, Section 2.44 ~AA0, Section 2.46~AA2, Section 2.47~AA3Evv, Section 2.48 ~AA4, Section 2.49 ~AA5PPSS

Related Topics:

Section A.2 Dual Watchdog Operation

2.46 ~AA2

Description:

Reads the host watchdog timeout value of a module.

Syntax:

~AA2[CHKSUM](CR)

- ~ Delimiter character
- AA Address of the module to be read (00 to FF)
- 2 Command to read the host watchdog timeout value

Response:

Valid command : **!AAEVV[CHKSUM](CR)**

Invalid command: **?AA[CHKSUM](CR)**

- ! Delimiter character for a valid command
- ? Delimiter character for an invalid command
- AA Address of the responding module (00 to FF)
- E 1: the host watchdog is enabled
0: the host watchdog is disabled
- VV Two hexadecimal digits to represent the timeout value in tenths of a second, for example, 01 denotes 0.1 seconds and FF denotes 25.5 seconds.

There will be no response if the command syntax is incorrect, there is a communication error, or there is no module with the specified address.

Examples:

Command: ~012

Response: !011FF

Reads the host watchdog timeout value of module 01 and returns FF, which denotes that the host watchdog is enabled and the host watchdog timeout value is 25.5 seconds.

Related Commands:

Section 2.43 ~**, Section 2.44 ~AA0, Section 2.45 ~AA1, Section 2.47 ~AA3EUV, Section 2.48 ~AA4, Section 2.49 ~AA5PPSS

Related Topics:

Section A.2 Dual Watchdog Operation

2.47 ~AA3E VV

Description:

Enables/disables the host watchdog and sets the host watchdog timeout value of a module.

Syntax:

~AA3E VV[CHKSUM](CR)

- ~ Delimiter character
- AA Address of the module to be set (00 to FF)
- 3 Command to set the host watchdog
- E 1: enable the host watchdog
0: disable the host watchdog
- VV Two hexadecimal digits to represent the timeout value in tenths of a second, for example, 01 denotes 0.1 seconds and FF denotes 25.5 seconds.

Response:

Valid command: **!AA[CHKSUM](CR)**

Invalid command: **?AA[CHKSUM](CR)**

- ! Delimiter character for a valid command
- ? Delimiter character for an invalid command
- AA Address of the responding module (00 to FF)

There will be no response if the command syntax is incorrect, there is a communication error, or there is no module with the specified address.

Examples:

Command: ~013164 Response: !01
Enables the host watchdog of module 01 and sets the host watchdog timeout value to 10.0 seconds. The module returns a valid response.

Command: ~012 Response: !01164
Reads the host watchdog timeout value of module 01. The module returns 164, which denotes that the host watchdog is enabled and the host watchdog timeout value is 10.0 seconds.

Related Commands:

Section 2.43 ~**, Section 2.44 ~AA0, Section 2.45 ~AA1, Section 2.46 ~AA2, Section 2.48 ~AA4, Section 2.49 ~AA5PPSS

Related Topics:

Section A.2 Dual Watchdog Operation

Notes:

When a host watchdog timeout occurs, the host watchdog is disabled. The ~AA3Evv command should be sent again to reenable the host watchdog.

2.48 ~AA4

Description:

Reads the power-on DO and safe DO values of a module.

Syntax:

~AA4[CHKSUM](CR)

- ~ Delimiter character
- AA Address of the module to be read (00 to FF)
- 4 Command to read the power-on DO and safe DO values

Response:

Valid command : **!AAPPSS[CHKSUM](CR)**

Invalid command: **?AA[CHKSUM](CR)**

- ! Delimiter character for a valid command
- ? Delimiter character for an invalid command
- AA Address of the responding module (00 to FF)
- PP Two hexadecimal digits to represent the power-on DO value.
- SS Two hexadecimal digits to represent the safe DO value.

There will be no response if the command syntax is incorrect, there is a communication error, or there is no module with the specified address.

Examples:

Command: ~014

Response: !010000

Reads the power-on DO value and the safe DO value of module 01 and returns 0000.

Related Commands:

Section 2.49 ~AA5PPSS

Related Topics:

Section 1.12 Digital Outputs and Alarms, Section A.2

Dual Watchdog Operation

Notes:

Both the power-on value and the safe value have no effect on the DO ports that are associated with alarm outputs.

2.49 ~AA5PPSS

Description:

Sets the power-on DO and safe DO values of a module.

Syntax:

~AA5PPSS[CHKSUM](CR)

- ~ Delimiter character
- AA Address of the module to be set (00 to FF)
- 5 Command to set the power-on and safe DO values
- PP Two hexadecimal digits to represent the power-on DO value.
- SS Two hexadecimal digits to represent the safe DO value.

Response:

Valid command: **!AA[CHKSUM](CR)**

Invalid command: **?AA[CHKSUM](CR)**

- ! Delimiter character for a valid command
- ? Delimiter character for an invalid command
- AA Address of the responding module (00 to FF)

There will be no response if the command syntax is incorrect, there is a communication error, or there is no module with the specified address.

Examples:

Command: ~0150000 Response: !01
Sets the power-on DO value to 0 and the safe DO value to 0. The module returns a valid response.

Command: ~014 Response: !010000
Reads the power-on DO value and the safe DO value of module 01. The module returns 0000, which denotes that both the power-on DO value and the safe DO value are 0.

Related Commands:

Section 2.48 ~AA4

Related Topics:

Section 1.12 Digital Output and Alarm, Section A.2 Dual Watchdog Operation

Notes:

Both the power-on value and the safe value have no effect on the DO ports that are associated with alarm outputs.

3. Modbus RTU Protocol

The Modbus protocol is developed by Modicon Inc., originally developed for Modicon controllers. Detailed information can be found at <http://www.modicon.com/techpubs/toc7.html>. You can also visit <http://www.modbus.org> to find more valuable information.

M-7000 series modules support the Modbus RTU protocol. The communication Baud Rates range from 1200bps to 115200bps. The parity, data bits and stop bits are fixed as no parity, 8 data bits and 1 stop bit. The following Modbus functions are supported by the M-7005.

Function Code	Description	Section
01 (0x01)	Read digital output status	3.1
02 (0x02)	Read input status	3.2
04 (0x04)	Read input channels	3.3
05 (0x05)	Write single digital output	3.4
15 (0x0F)	Write multiple digital outputs	3.5
70 (0x46)	Read/write module settings	3.6

If the function specified in the message is not supported, then the module responds as follows.

Error Response

00	Address	1 Byte	1 to 247
01	Function code	1 Byte	Function code 0x80
02	Exception code	1 Byte	01

If a CRC mismatch occurs, the module will not respond.

3.1 01 (0x01) Read Digital Output Status

This function code is used to read the digital output channel status of a module.

Request

00	Address	1 Byte	1 to 247
01	Function code	1 Byte	0x01
02 ~ 03	Starting channel	2 Bytes	0x00 to 0x05, where 0x00 corresponds to channel 0, 0x01 corresponds to channel 1, etc
04 ~ 05	Number of digital output channels	2 Bytes	N, 1 to 6; (Starting channel + N) should be less than or equal to 0x06

Response

00	Address	1 Byte	1 to 247
01	Function code	1 Byte	0x01
02	Byte count	1 Byte	1
03	Data of digital output channels	1 Byte	A bit corresponds to a channel. When the bit is 1 it denotes that the channel is ON. If the bit is 0 it denotes that the channel is OFF.

Error Response

00	Address	1 Byte	1 to 247
01	Function code	1 Byte	0x81
02	Exception code	1 Byte	02: starting channel out of range 03: (starting channel + number of digital output channels) out of range, incorrect number of bytes received

3.2 02 (0x02) Read Input Status

This function code is used to read the thermistor wire opening status of a module.

Request

00	Address	1 Byte	1 to 247
01	Function code	1 Byte	0x02
02 ~ 03	Starting channel	2 Bytes	0x80 to 0x87, where 0x80 corresponds to channel 0, 0x81 corresponds to channel 1, etc
04 ~ 05	Number of input channels	2 Bytes	N, 1 to 8; (Starting channel + N) should be less than or equal to 0x88

Response

00	Address	1 Byte	1 to 247
01	Function code	1 Byte	0x02
02	Byte count	1 Byte	1
03	Data of input channels	1 Byte	A bit corresponds to a channel. When the bit is 1 it denotes that the channel is enabled and is either over-range, under-range or wire opening. If the bit is 0 it denotes that the channel is disabled or normal.

Error Response

00	Address	1 Byte	1 to 247
01	Function code	1 Byte	0x82
02	Exception code	1 Byte	02: starting channel out of range 03: (starting channel + number of input channels) out of range, incorrect number of bytes received

3.3 04 (0x04) Read Input Channels

This function code is used to read from contiguous analog input channels.

Request

00	Address	1 Byte	1 to 247
01	Function code	1 Byte	0x04
02 ~ 03	Starting channel	2 Bytes	0 to 7
04 ~ 05	Number of input channels (N)	2 Bytes	1 to 8; (Starting channel + N) <= 8.

Response

00	Address	1 Byte	1 to 247
01	Function code	1 Byte	0x04
02	Byte count	1 Byte	2 x N
03 ~	Data of input channels	2 x N Bytes	Data in 2's complement hex format.

Error Response

00	Address	1 Byte	1 to 247
01	Function code	1 Byte	0x84
02	Exception code	1 Byte	02: starting channel out of range 03: (starting channel + number of input channels) out of range, incorrect number of bytes received

3.4 05 (0x05) Write Single Digital Output

This function code is used to write to one digital output channel.

Request

00	Address	1 Byte	1 to 247
01	Function code	1 Byte	0x05
02 ~ 03	Channel	2 Bytes	0 to 5
04 ~ 05	Data	2 Bytes	FF00h for ON and 0000h for OFF.

Response

00	Address	1 Byte	1 to 247
01	Function code	1 Byte	0x04
02 ~ 03	Channel	2 Bytes	0 to 5
04 ~ 05	Data	2 Bytes	FF00h for ON and 0000h for OFF.

Error Response

00	Address	1 Byte	1 to 247
01	Function code	1 Byte	0x85
02	Exception code	1 Byte	02: channel out of range

3.5 15 (0x0F) Write Multiple Digital Output Channels

This function code is used to write to multiple digital output channels.

Request

00	Address	1 Byte	1 to 247
01	Function code	1 Byte	0x0F
02 ~ 03	Starting channel	2 Bytes	0 to 5
04 ~ 05	Number of channels (N)	2 Bytes	1 to 6; (Starting channel + N) <= 6.
06	Byte count	1 Byte	1
07 ~	Data of digital output channels	1 Byte	A bit corresponds to a channel. When the bit is 1 it denotes that the channel is ON. If the bit is 0 it denotes that the channel is OFF.

Response

00	Address	1 Byte	1 to 247
01	Function code	1 Byte	0x0F
02 ~ 03	Starting channel	2 Bytes	0 to 5
04 ~ 05	Number of channels (N)	2 Bytes	1 to 6

Error Response

00	Address	1 Byte	1 to 247
01	Function code	1 Byte	0x8F
02	Exception code	1 Byte	02: starting channel out of range 03: (starting channel + number of channels) out of range, incorrect number of bytes received

3.6 70 (0x46) Read/Write Module Settings

This function code is used to read the settings of the module or change the settings of the module. The following sub-function codes are supported.

Sub-function Code	Description	Section
00 (0x00)	Read the module name	3.6.1
04 (0x04)	Set the module address	3.6.2
05 (0x05)	Read the communication settings	3.6.3
06 (0x06)	Set the communication settings	3.6.4
07 (0x07)	Read the type code	3.6.5
08 (0x08)	Set the type code	3.6.6
32 (0x20)	Read the firmware version	3.6.7
37 (0x25)	Read the channel enable/disable status	3.6.8
38 (0x26)	Set the channel enable/disable	3.6.9
41 (0x29)	Read the miscellaneous settings	3.6.10
42 (0x2A)	Write the miscellaneous settings	3.6.11

If the module does not support the sub-function code specified in the message, then it responds as follows.

Error Response

00	Address	1 Byte	1 to 247
01	Function code	1 Byte	0xC6
02	Exception code	1 Byte	02: invalid sub-function code

3.6.1 Sub-function 00 (0x00) Read module name

This sub-function code is used to read the name of a module.

Request

00	Address	1 Byte	1 to 247
01	Function code	1 Byte	0x46
02	Sub function code	1 Byte	0x00

Response

00	Address	1 Byte	1 to 247
01	Function code	1 Byte	0x46
02	Sub function code	1 Byte	0x00
03 ~ 06	Module name	4 Bytes	0x00 0x70 0x05 0x00 for M-7005

Error Response

00	Address	1 Byte	1 to 247
01	Function code	1 Byte	0xC6
02	Exception code	1 Byte	03: incorrect number of bytes received

3.6.2 Sub-function 04 (0x04) Set module address

This sub-function code is used to set the address of a module.

Request

00	Address	1 Byte	1 to 247
01	Function code	1 Byte	0x46
02	Sub function code	1 Byte	0x04
03	New address	1 Byte	1 to 247
04 ~ 06	Reserved	3 Bytes	0x00 0x00 0x00

Response

00	Address	1 Byte	1 to 247
01	Function code	1 Byte	0x46
02	Sub function code	1 Byte	0x04
03	Set address result	1 Byte	0: OK, others: error
04 ~ 06	Reserved	3 Bytes	0x00 0x00 0x00

Error Response

00	Address	1 Byte	1 to 247
01	Function code	1 Byte	0xC6
02	Exception code	1 Byte	03: new address out of range, reserved bytes should be filled with zero, incorrect number of bytes received

3.6.3 Sub-function 05 (0x05) Read communication settings

This sub-function code is used to read the communication protocol settings of a module.

Request

00	Address	1 Byte	1 to 247
01	Function code	1 Byte	0x46
02	Sub function code	1 Byte	0x05
03	Reserved	1 Byte	0x00

Response

00	Address	1 Byte	1 to 247
01	Function code	1 Byte	0x46
02	Sub function code	1 Byte	0x05
03	Reserved	1 Byte	0x00
04	Baud Rate	1 Byte	Baud Rate code, see Section 1.11 for details.
05 ~ 07	Reserved	3 Bytes	0x00 0x00 0x00
08	Mode	1 Byte	0: DCON protocol 1: Modubs RTU protocol
09 ~ 10	Reserved	2 Bytes	0x00 0x00

Note: This information is the data saved in the EEPROM and will be used for the next power-on reset. It is not the currently used settings.

Error Response

00	Address	1 Byte	1 to 247
01	Function code	1 Byte	0xC6
02	Exception code	1 Byte	03: reserved byte should be filled with zero, incorrect number of bytes received

3.6.4 Sub-function 06 (0x06) Set communication settings

This sub-function code is used to set the communication protocol of a module.

Request

00	Address	1 Byte	1 to 247
01	Function code	1 Byte	0x46
02	Sub function code	1 Byte	0x06
03	Reserved	1 Byte	0x00
04	Baud Rate	1 Byte	Baud Rate code, see Section 1.11 for details.
05 ~ 07	Reserved	3 Bytes	0x00 0x00 0x00
08	Mode	1 Byte	0: DCON protocol 1: Modubs RTU protocol
09 ~ 10	Reserved	2 Bytes	0x00 0x00

Response

00	Address	1 Byte	1 to 247
01	Function code	1 Byte	0x46
02	Sub function code	1 Byte	0x06
03	Reserved	1 Byte	0x00
04	Baud Rate	1 Byte	0: OK, others: error
05 ~ 07	Reserved	3 Bytes	0x00 0x00 0x00
08	Mode	1 Byte	0: OK, others: error
09 ~ 10	Reserved	2 Bytes	0x00 0x00

Note: The new Baud Rate and protocol will be effective after the next power-on reset.

Error Response

00	Address	1 Byte	1 to 247
01	Function code	1 Byte	0xC6
02	Exception code	1 Byte	03: Baud Rate or mode out of range, reserved bytes should be filled with zero, incorrect number of bytes received

3.6.5 Sub-function 07 (0x07) Read type code

This sub-function code is used to read the type code information of a module.

Request

00	Address	1 Byte	1 to 247
01	Function code	1 Byte	0x46
02	Sub function code	1 Byte	0x07
03	Reserved	1 Bytes	0x00
04	Channel	1 Byte	0x00 ~ 0x07 for M-7005

Response

00	Address	1 Byte	1 to 247
01	Function code	1 Byte	0x46
02	Sub function code	1 Byte	0x07
03	Type code	1 Byte	Type code, see Section 1.10 for details.

Error Response

00	Address	1 Byte	1 to 247
01	Function code	1 Byte	0xC6
02	Exception code	1 Byte	03: reserved bytes should be filled with zero, channel out of range, incorrect number of bytes received

3.6.6 Sub-function 08 (0x08) Set type code

This sub-function code is used to set the type code of a module.

Request

00	Address	1 Byte	1 to 247
01	Function code	1 Byte	0x46
02	Sub function code	1 Byte	0x08
03	Reserved	1 Byte	0x00
04	Channel	1 Byte	0x00 ~ 0x07 for M-7005
05	Type code	1 Byte	Type code, see Section 1.10 for details.

Response

00	Address	1 Byte	1 to 247
01	Function code	1 Byte	0x46
02	Sub function code	1 Byte	0x08
03	Type code	1 Byte	0: OK others: error

Error Response

00	Address	1 Byte	1 to 247
01	Function code	1 Byte	0xC6
02	Exception code	1 Byte	03: type code out of range, channel out of range, reserved bytes should be filled with zero, incorrect number of bytes received

3.6.7 Sub-function 32 (0x20) Read firmware version

This sub-function code is used to read the firmware version information of a module.

Request

00	Address	1 Byte	1 to 247
01	Function code	1 Byte	0x46
02	Sub function code	1 Byte	0x20

Response

00	Address	1 Byte	1 to 247
01	Function code	1 Byte	0x46
02	Sub function code	1 Byte	0x20
03	Major version	1 Byte	0x00 ~ 0xFF
04	Minor version	1 Byte	0x00 ~ 0xFF
05	Build version	1 Byte	0x00 ~ 0xFF

Error Response

00	Address	1 Byte	1 to 247
01	Function code	1 Byte	0xC6
02	Exception code	1 Byte	03: incorrect number of bytes received

3.6.8 Sub-function 37 (0x25) Read channel enabled/disabled status

This sub-function code is used to read the enabled/disabled status of each channel in a module.

Request

00	Address	1 Byte	1 to 247
01	Function code	1 Byte	0x46
02	Sub function code	1 Byte	0x25

Response

00	Address	1 Byte	1 to 247
01	Function code	1 Byte	0x46
02	Sub function code	1 Byte	0x25
03	Enabled/disabled status	1 Byte	0x00 ~ 0xFF, enabled/disabled status of each channel, where bit 0 corresponds to channel 0, bit 1 corresponds to channel 1, etc. When the bit is 1 it denotes that the channel is enabled and 0 denotes that the channel is disabled.

Error Response

00	Address	1 Byte	1 to 247
01	Function code	1 Byte	0xC6
02	Exception code	1 Byte	03: incorrect number of bytes received

3.6.9 Sub-function 38 (0x26) Set channel enable/disable

This sub-function code is used to specify the channels to be enabled in a module.

Request

00	Address	1 Byte	1 to 247
01	Function code	1 Byte	0x46
02	Sub function code	1 Byte	0x26
03	Enable/disable setting	1 Byte	0x00 ~ 0xFF, enable/disable setting of each channel, where bit 0 corresponds to channel 0, bit 1 corresponds to channel 1, etc. When the bit is 1 it denotes that the channel is enabled and 0 denotes that the channel is disabled.

Response

00	Address	1 Byte	1 to 247
01	Function code	1 Byte	0x46
02	Sub function code	1 Byte	0x26
03	Enable/disable setting	1 Byte	0: OK others: error.

Error Response

00	Address	1 Byte	1 to 247
01	Function code	1 Byte	0xC6
02	Exception code	1 Byte	03: enable/disable setting out of range, incorrect number of bytes received

3.6.10 Sub-function 41 (0x29) Read miscellaneous settings

This sub-function code is used to read the miscellaneous settings of a module.

Request

00	Address	1 Byte	1 to 247
01	Function code	1 Byte	0x46
02	Sub function code	1 Byte	0x29

Response

00	Address	1 Byte	1 to 247
01	Function code	1 Byte	0x46
02	Sub function code	1 Byte	0x29
03	Miscellaneous settings	1 Byte	0, not used for M-7005

Note: The reserved fields are filled with zeros.

Error Response

00	Address	1 Byte	1 to 247
01	Function code	1 Byte	0xC6
02	Exception code	1 Byte	03: incorrect number of bytes received

3.6.11 Sub-function 42 (0x2A) Write miscellaneous settings

This sub-function code is used to set the miscellaneous settings of a module.

Request

00	Address	1 Byte	1 to 247
01	Function code	1 Byte	0x46
02	Sub function code	1 Byte	0x2A
03	Miscellaneous settings	1 Byte	0, not used for M-7005

Note: The reserved fields are filled with zeros.

Response

00	Address	1 Byte	1 to 247
01	Function code	1 Byte	0x46
02	Sub function code	1 Byte	0x2A
03	Miscellaneous settings	1 Byte	0: OK others: error

Error Response

00	Address	1 Byte	1 to 247
01	Function code	1 Byte	0xC6
02	Exception code	1 Byte	03: reserved bits should be filled with zero, incorrect number of bytes received

3.7 M-7005 Address Mappings

Address	Description	Attribute
00001 ~ 00006	Digital output value of channel 0 to 5	R/W
00097 ~ 00102	Safe value of digital output channel 0 to 5	R/W
00193 ~ 00198	Power-on value of digital output channel 0 to 5	R/W
00257	Protocol, 0: DCON, 1: Modbus RTU	R/W
00260	Modbus host watchdog mode 0: same as I-7000 1: can use AO and DO command to clear host watchdog timeout status	R/W
00261	1: enable, 0: disable host watchdog	R/W
00267	Temperature scale, 1: Celsius, 0: Fahrenheit	R/W
00269	Modbus data format, 0: hex, 1: engineering	R/W
00270	Host watch dog timeout status, write 1 to clear host watch dog timeout status	R/W
00272	Write 1 to load factory calibration parameters	W
00273	Reset status, 1: first read after powered on, 0: not the first read after powered on	R
00289 ~ 00296	Write 1 to clear low latched alarm of channel 0 to 7	W
00305 ~ 00312	Write 1 to clear high latched alarm of channel 0 to 7	W
00321 ~ 00328	Enable/disable high alarm of channel 0 to 7	R/W
00329 ~ 00336	Enable/disable low alarm of channel 0 to 7	R/W

Address	Description	Attribute
00337 ~ 00344	High alarm type of channel 0 to 7, 0: latched, 1: momentary	R/W
00345 ~ 00352	Low alarm type of channel 0 to 7, 0: latched, 1: momentary	R/W
10129 ~ 10136 00129 ~ 00136	Over/under range status of channel 0 to 7	R
30001 ~ 30008 40001 ~ 40008	Analog input value of channel 0 to 7	R
40225 ~ 40232	High alarm limit of channel 0 to 7	R/W
40233 ~ 40240	Low alarm limit of channel 0 to 7	R/W
40257 ~ 40262	Type code of channel 0 to 7	R/W
40289 ~ 40294	Temperature offset of channel 0 to 7 in 0.1°C, valid range: -128 ~ 127	R/W
40321 ~ 40328	High alarm DO port of channel 0 to 7	R/W
40329 ~ 40336	Low alarm DO port of channel 0 to 7	R/W
40385 ~ 40390	Resistance offset of channel 0 to 7 in 0.1 ohms, valid range: 0 ~ 255	R/W

Address	Description	Attribute																				
40481	Firmware version (low word)	R																				
40482	Firmware version (high word)	R																				
40483	Module name (low word)	R																				
40484	Module name (high word)	R																				
40485	Module address, valid range: 1 ~ 247	R/W																				
40486	Bits 5:0 Baud rate, 0x03 ~ 0x0A <table border="1" data-bbox="400 629 1066 808"> <tbody> <tr> <td>Code</td> <td>0x03</td> <td>0x04</td> <td>0x05</td> <td>0x06</td> </tr> <tr> <td>Baud</td> <td>1200</td> <td>2400</td> <td>4800</td> <td>9600</td> </tr> <tr> <td>Code</td> <td>0x07</td> <td>0x08</td> <td>0x09</td> <td>0x0A</td> </tr> <tr> <td>Baud</td> <td>19200</td> <td>38400</td> <td>57600</td> <td>115200</td> </tr> </tbody> </table> Bits 7:6 00: no parity, 1 stop bit 01: no parity, 2 stop bits 10: even parity, 1 stop bit 11: odd parity, 1 stop bit	Code	0x03	0x04	0x05	0x06	Baud	1200	2400	4800	9600	Code	0x07	0x08	0x09	0x0A	Baud	19200	38400	57600	115200	R/W
Code	0x03	0x04	0x05	0x06																		
Baud	1200	2400	4800	9600																		
Code	0x07	0x08	0x09	0x0A																		
Baud	19200	38400	57600	115200																		
40488	Modbus response delay time in ms, valid range: 0 ~ 30	R/W																				
40489	Host watchdog timeout value, 0 ~ 255, in 0.1s	R/W																				
40490	Channel enable/disable	R/W																				
40492	Host watchdog timeout count, write 0 to clear	R/W																				
40513 ~ 40520	Steinhart Coefficient A of type code 70 to 77	R/W																				
40545 ~ 40552	Steinhart Coefficient B of type code 70 to 77	R/W																				
40577 ~ 40584	Steinhart Coefficient C of type code 70 to 77	R/W																				

3.8 M-7005 Engineering Data Format Table

Type Code	Thermistor Type	-F.S.	+F.S.
60	PreCon Type III 10K @ 25°C	-3000	24000
61	Fenwell Type U 2K @ 25°C	-5000	15000
62	Fenwell Type U 2K @ 25°C	0	15000
63	YSI L Mix 100 @ 25°C	-8000	10000
64	YSI L Mix 300 @ 25°C	-8000	10000
65	YSI L Mix 1000 @ 25°C	-7000	10000
66	YSI B Mix 2252 @ 25°C	-5000	15000
67	YSI B Mix 3000 @ 25°C	-4000	15000
68	YSI B Mix 5000 @ 25°C	-4000	15000
69	YSI B Mix 6000 @ 25°C	-3000	15000
6A	YSI B Mix 10000 @ 25°C	-3000	15000
6B	YSI H Mix 10000 @ 25°C	-3000	15000
6C	YSI H Mix 30000 @ 25°C	-1000	20000
70	User-defined	-5000	15000
71	User-defined	-5000	15000
72	User-defined	-5000	15000
73	User-defined	-5000	15000
74	User-defined	-5000	15000
75	User-defined	-5000	15000
76	User-defined	-5000	15000
77	User-defined	-5000	15000

The under range value is -32768 and the over range value is +32767. For the hex data format, please refer to Section 1.10.

4. Troubleshooting

If you are having difficulty using the I-7000 series module, here are some suggestions that may help. If you cannot find the answers you need in these guides, contact ICP DAS Product Support. Contact information is located in Section 1.15.

4.1 Communicating with the module

If you attempt to communicate with the module and receive no response, first check the following:

- Ensure that the supplied power is within the range of +10 to +30 V DC. If the supplied power is OK, then the power LED should be on.
- When the module receives a command, the power LED is set to “off”. The power LED is shown as “on” after the module responds. This method can be used to check whether the module has received a command sent from the host.
- If possible, use another device to check whether the host can communicate with the device through the same RS-485 network.
- If the host is a PC installed with a Windows operating system, then execute the DCON Utility to determine whether the module can be found. The DCON Utility can be downloaded from the ICP DAS website <http://www.icpdas.com>. The DCON Utility documentation can be found in the ”**Getting Started For I-7000 Series Modules**” manual.
- Set the module to “INIT mode” and communicate with the module using the following settings: address 00, Baud Rate 9600bps and no checksum. See Section A.1 for details.

4.2 Reading Data

If the data read from the input channel is not correct, first check the following:

- Ensure that the type code and data format settings are correct. For the I-7005, the type code is set by using the \$AA7CiRrr command, see Section 2.12 for details. The data format is set by using the %AANNTTCCFF command.
- Connect a resistor, instead of thermistor sensor, using the thermistor connection as shown in Section 1.6. The resistance of the resistor should be less than 180000 ohms. Change the data format to ohms, see Sections 1.10 and 2.1, and check whether the data reading is correct.
- If the resistance read by the module is still incorrect, then it may be because the calibration parameters stored in the non-volatile memory are corrupted, which means that the module should be recalibrated. Be sure to read Section 1.9 in detail before performing the calibration. For the I-7005 and M-7005, you can send the \$AAS1 command, see Section 2.21 for details, to reload the factory calibration parameters.

A. Appendix

A.1 INIT Mode

Each I-7000 and M-7000 module has a built-in EEPROM to store configuration information such as module address, type code, Baud Rate, etc. Occasionally, the configuration of a module may be forgotten and there are no visual indications of the configuration of the module. It is difficult to communicate with the module when the configuration of the module is unknown. To help avoid this problem, the I-7000 and M-7000 series has a special mode called **“INIT mode”**. When the module is powered on in **“INIT mode”** the configuration of the module is reset as follows, allowing it to be operated as normal.

1. Address: 00
2. Baud Rate: 9600 bps
3. No checksum
4. Protocol: DCON

The configuration information stored in the EEPROM is not changed and can be read by sending the \$002(CR) command at 9600bps.

There are commands that require the module to be in INIT mode. They are:

1. %AANNTTCCFF when changing Baud Rate and checksum settings. See Section 2.1 for details.
2. \$AAPN, see Section 2.24 for details.

Originally, the INIT mode is accessed by connecting the INIT* terminal to the GND terminal. New I-7000 and M-7000 modules have the INIT switch located on the rear side of the module allow easier access to the INIT mode. For these modules, INIT mode is accessed by sliding the INIT switch to the Init position as shown below.

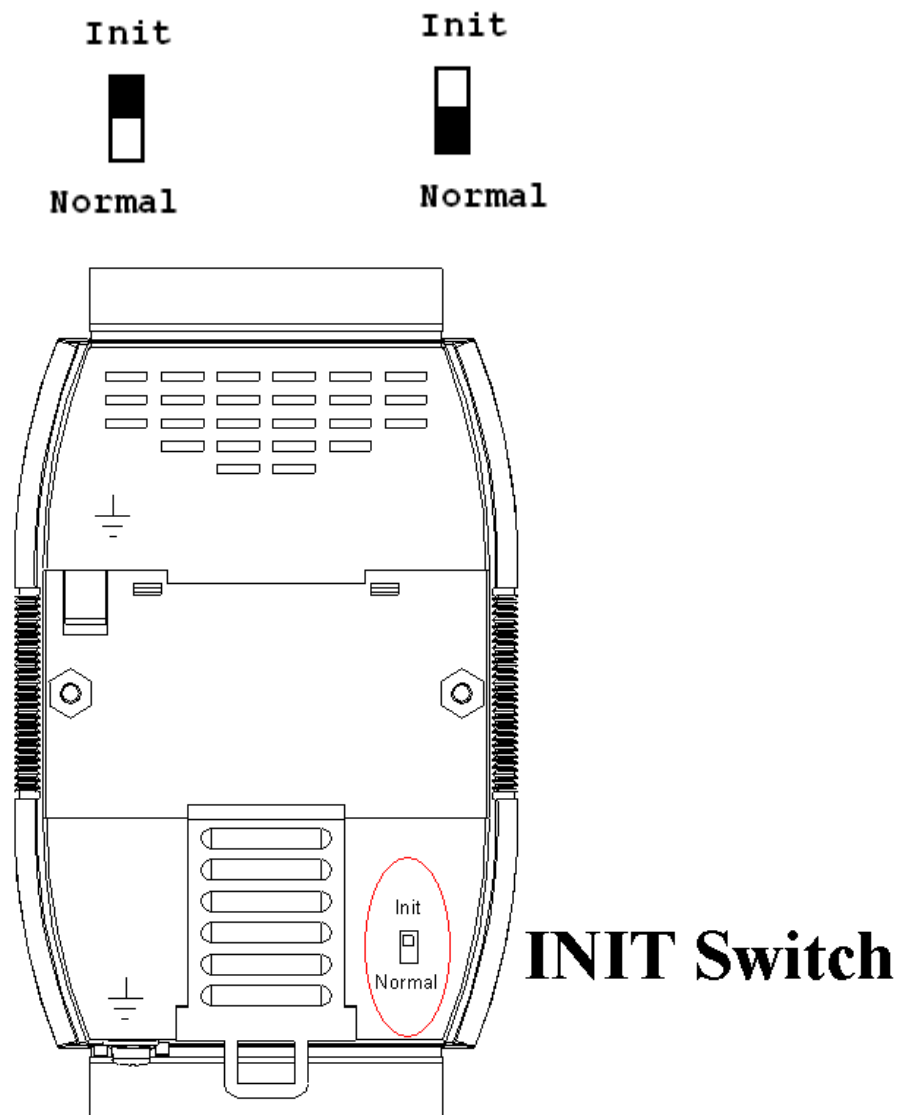

A.2 Dual Watchdog Operation

Dual Watchdog = Module Watchdog + Host Watchdog

The Module Watchdog is a hardware reset circuit that monitors the operating status of the module. While working in harsh or noisy environments, the module may be shut down by external signals. The circuit allows the module to work continuously without disruption.

The Host Watchdog is a software function that monitors the operating status of the host. Its purpose is to prevent problems due to network/communication errors or host malfunctions. When a host watchdog timeout occurs, the module will reset all outputs to a safe state in order to prevent any erroneous operations of the controlled target.

I-7000 and M-7000 series modules include an internal Dual Watchdog, making the control system more reliable and stable.

For more information regarding the Dual Watchdog, please refer to Chapter 5 of the “**Getting Started For I-7000 Series Modules**” manual that can be downloaded from the ICP DAS website <http://www.icpdas.com>.

A.3 Frame Ground

Electronic circuits are constantly vulnerable to Electro-Static Discharge (ESD), which become worse in a continental climate area. Some I-7000 and M-7000 modules feature a new design for the frame ground, which provides a path for bypassing ESD, allowing enhanced static protection (ESD) capability and ensures that the module is more reliable.

Either of the following options will provide a better protection for the module:

1. If the module is DIN rail mounted, connect the DIN rail to the earth ground because the DIN rail is in contact with the upper frame ground as shown in the figure below.
2. Alternatively, connect the lower frame ground terminal to a wire and connect the wire to the earth ground, as shown in the figure below.

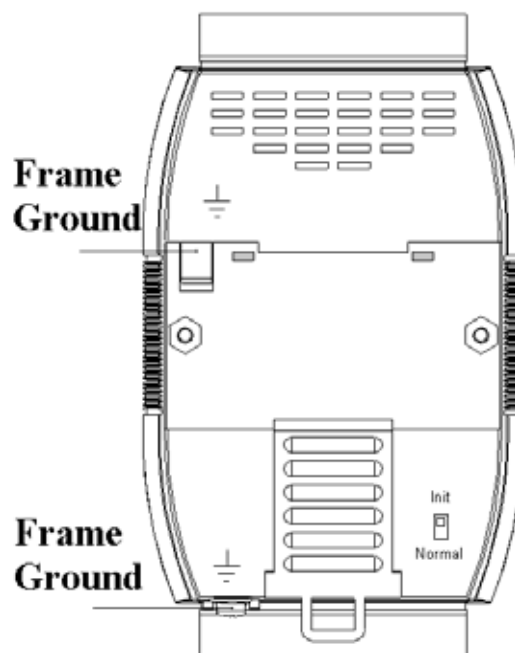

New DIN rail models are available that can easily be connected to the earth ground. Each is made of stainless steel, which is stronger than those made of aluminum. There is a screw at one end and a ring terminal is included as shown in the figure below. Refer to Section 1.14.1 for more information about the new DIN rail models.

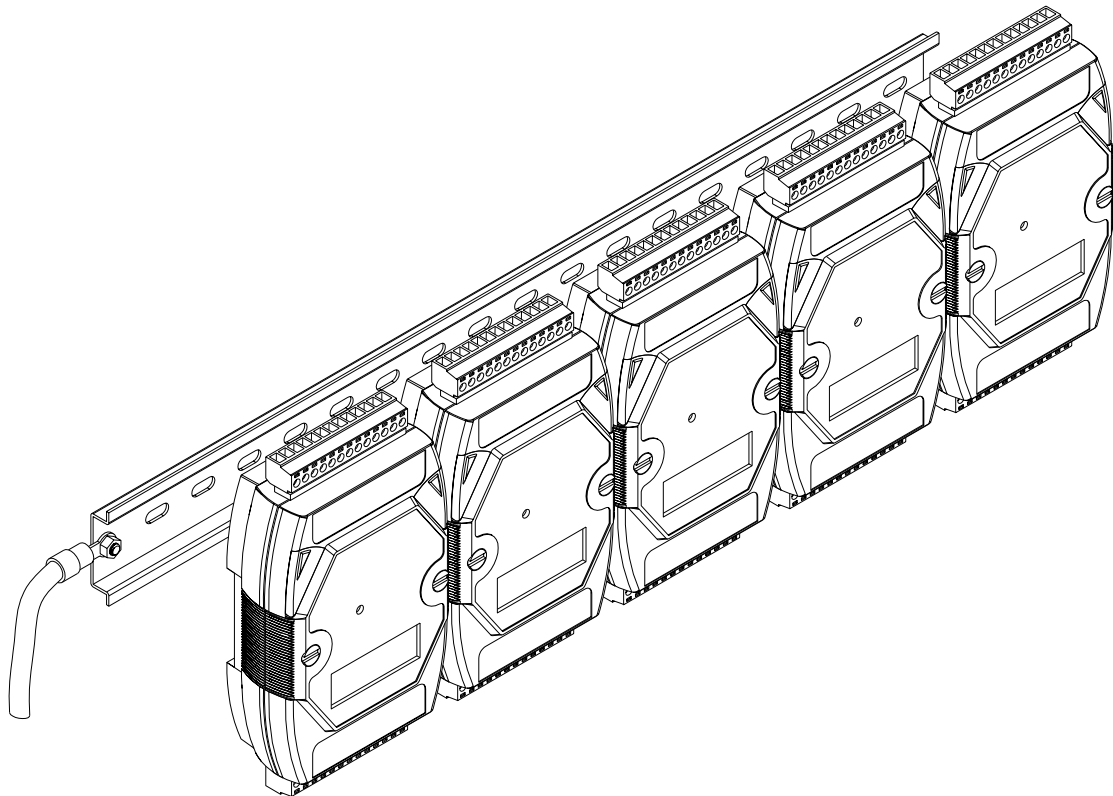

A.4 Node Information Area

Each I-7000 and M-7000 module has a built-in EEPROM to store configuration information such as module address, type code, Baud Rate, etc. One minor drawback is that there are no visual indications of the configuration of the module. New I-7000 and M-7000 modules include node information areas that are protected by a cover, as shown below, and can be used to make a written record of the node information, such as module address, Baud Rate, etc. To access the node information areas, first slide the covers outward, as shown in the figure below.

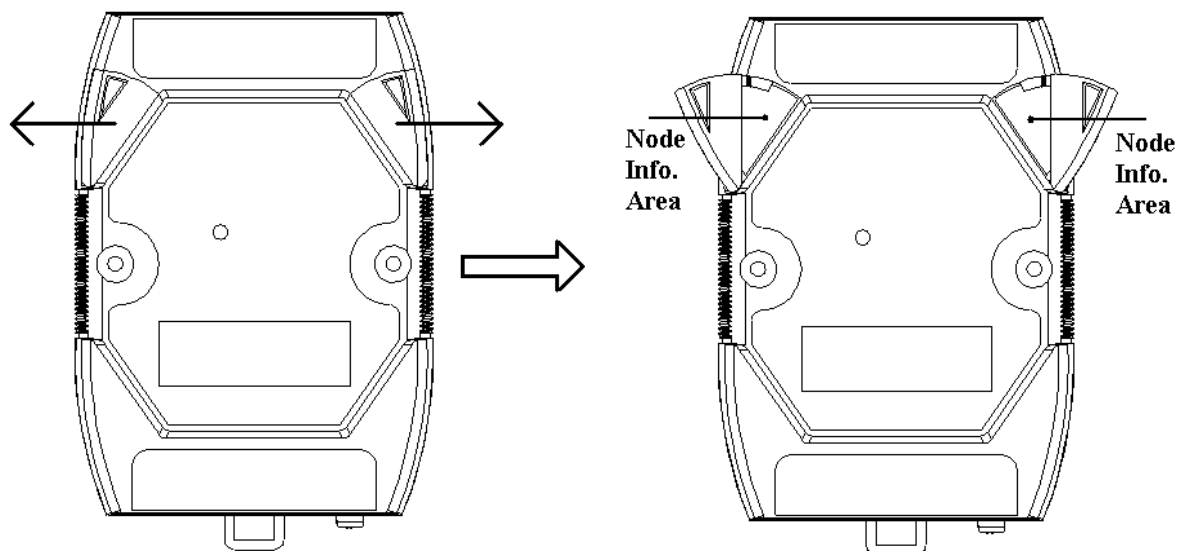

A.5 Thermistor

A thermistor is a temperature sensitive resistor that can be used in temperature measurement, control and compensation circuitry. For most thermistors, the resistance decreases as the temperature rises and the relationship can be expressed as:

$$1/T = A + B \ln R_T + C (\ln R_T)^3$$

where R_T is the resistance in ohms at the temperature T in Kelvins ($K = ^\circ C + 273.15$). This is called the Steinhart-Hart equation.

Thermistors typically work over a relatively small temperature range of $-60^\circ C$ to $300^\circ C$. They are less stable than RTDs. However, they exhibit a large change in resistance proportional to a small change in temperature than RTDs and a much higher nominal resistance. They are less sensitive to lead resistance noise effects and can be transmitted over a large distance. No compensation for ambient temperature is needed. They are one of the most accurate types of temperature sensors.

A.6 Resistance Measurement

The I-7005 and M-7005 modules can be used for resistance measurement. To measure the resistance, connect the resistor using thermistor connection, as shown in Section 1.6, and set the data format to ohms. To set the data format, send the %AANNTCCFF command to the module, see Section 2.1 for details, or use the DCON utility, refer to Chapter 2 of the “**Getting Started For I-7000 Series Modules**” manual that can be downloaded from the ICP DAS website <http://www.icpdas.com>.

The maximum resistance that can be measured by I-7005 and M-7005 is 180000 ohms for firmware version A2.3 and earlier, and 204800 ohms for firmware version A3.7 and later.

When set to ohm data format, the maximum resistance that can be measured for type code 71 ~ 77 for firmware version A3.7 and later are as follows.

Type	max resistance
71	3200 Ohms
72	6400 Ohms
73	12800 Ohms
74	25600 Ohms
75	51200 Ohms
76	102400 Ohms
77	204800 Ohms