

TOP-MOUNT REFRIGERATOR

Use & Care Guide

Table of Contents..... 2

TABLE OF CONTENTS

REFRIGERATOR SAFETY	3
INSTALLING YOUR REFRIGERATOR	4
Unpacking Your Refrigerator	4
Space Requirements.....	4
Electrical Requirements	5
Connecting the Refrigerator to a Water Source	5
Refrigerator Doors: Removing, Reversing and Replacing	7
Door Closing and Alignment.....	8
Understanding Sounds You May Hear.....	9
USING YOUR REFRIGERATOR	9
Ensuring Proper Air Circulation.....	9
Setting the Control(s)	10
Adjusting Control Settings	10
REFRIGERATOR FEATURES	11
Refrigerator Shelves.....	11
Meat Drawer and Cover.....	11
Crisper and Crisper Cover	11
Utility or Egg Bin	12
FREEZER FEATURES	12
Ice Maker.....	12
Freezer Shelf	13
DOOR FEATURES	13
Drop-in Door Rails.....	13
CARING FOR YOUR REFRIGERATOR	13
Cleaning Your Refrigerator	13
Changing the Light Bulb	14
Power Interruptions.....	14
Vacation and Moving Care	14
TROUBLESHOOTING	15
ASSISTANCE OR SERVICE	17
WARRANTY	18

REFRIGERATOR SAFETY

Your safety and the safety of others are very important.

We have provided many important safety messages in this manual and on your appliance. Always read and obey all safety messages.



This is the safety alert symbol.

This symbol alerts you to potential hazards that can kill or hurt you and others.

All safety messages will follow the safety alert symbol and either the word "DANGER" or "WARNING." These words mean:

! DANGER

You can be killed or seriously injured if you don't immediately follow instructions.

! WARNING

You can be killed or seriously injured if you don't follow instructions.

All safety messages will tell you what the potential hazard is, tell you how to reduce the chance of injury, and tell you what can happen if the instructions are not followed.

IMPORTANT SAFETY INSTRUCTIONS

WARNING: To reduce the risk of fire, electric shock, or injury when using your refrigerator, follow these basic precautions:

- Plug into a grounded 3 prong outlet.
- Do not remove ground prong.
- Do not use an adapter.
- Do not use an extension cord.
- Disconnect power before servicing.
- Replace all panels before operating.
- Remove doors from your old refrigerator.
- Use nonflammable cleaner.
- Keep flammable materials and vapors, such as gasoline, away from refrigerator.
- Use two or more people to move and install refrigerator.
- Disconnect power before installing ice maker (on ice maker kit ready models only).
- Use a sturdy glass when dispensing ice or water (on some models).

SAVE THESE INSTRUCTIONS

Proper Disposal of Your Old Refrigerator

! WARNING

Suffocation Hazard

Remove doors from your old refrigerator.

Failure to do so can result in death or brain damage.

IMPORTANT: Child entrapment and suffocation are not problems of the past. Junked or abandoned refrigerators are still dangerous – even if they will sit for "just a few days." If you are getting rid of your old refrigerator, please follow these instructions to help prevent accidents.

Before you throw away your old refrigerator or freezer:

- Take off the doors.
- Leave the shelves in place so that children may not easily climb inside.

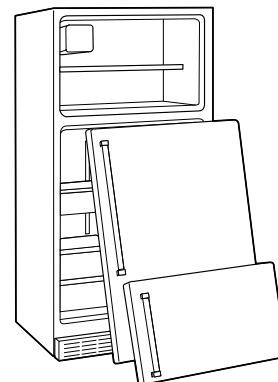

INSTALLING YOUR REFRIGERATOR

Unpacking Your Refrigerator

⚠️ WARNING

Excessive Weight Hazard

Use two or more people to move and install refrigerator.

Failure to do so can result in back or other injury.

Remove shelves from the shipping position (shelves are shipped upside down):

IMPORTANT: Do not clean glass shelves with warm water when they are cold. Shelves may break if exposed to sudden temperature changes or impact, such as bumping. For your protection, tempered glass is designed to shatter into many small pebble-size pieces. This is normal.

NOTE: Glass shelves are heavy. Use special care when removing them to avoid impact from dropping.

1. Grasp the front of the upper shelf with one hand and use the other hand to remove packing material from the shelf area.
2. Lower the front of the upper shelf until shelf hooks can be removed from the shelf supports and pull the shelf forward.
3. Flip the shelf over and insert the rear shelf hooks into the shelf supports. Tilt the front of shelf up until rear shelf hooks drop into the shelf supports.
4. Lower the front of the shelf and check to make sure that it is securely in position.

Removing packaging materials

- Remove tape and any labels from your refrigerator before using (except the model and serial number label).
To remove any remaining tape or glue, rub the area briskly with your thumb. Tape or glue residue can also be easily removed by rubbing a small amount of liquid dish soap over the adhesive with your fingers. Wipe with warm water and dry.
- Do not use sharp instruments, rubbing alcohol, flammable fluids, or abrasive cleaners to remove tape or glue. These products can damage the surface of your refrigerator. For more information, see "Refrigerator Safety" section.
- On some models, shelves, bins, door shelf rails, and other feature parts may be packaged in the Interior FeaturePak. Follow the instructions contained in the package for proper assembly.

IMPORTANT:

- Depending on your model, do not remove any permanent instruction labels inside your refrigerator or the Tech Sheet that is fastened behind the base grille.
- Depending on your model, do not remove the white Styrofoam insert that is located behind the control panel on the ceiling of the refrigerator. The insert is part of the refrigerator and not part of the packing material. If the insert is removed, ice may migrate down from the freezer and cause icicles to form.

When Moving Your Refrigerator:

Your refrigerator is heavy. When moving the refrigerator for cleaning or service, be sure to protect the floor. Always pull the refrigerator straight out when moving it. Do not wiggle or "walk" the refrigerator when trying to move it, as floor damage could occur.

Space Requirements

⚠️ WARNING



Explosion Hazard

Keep flammable materials and vapors, such as gasoline, away from refrigerator.

Failure to do so can result in death, explosion, or fire.

- To ensure proper ventilation for your refrigerator, allow for a .5 in. (1.25 cm) space on each side
- Allow 3 in. (7.5 cm) of space between overhead cabinets and refrigerator top.
- Allow at least 1 in. (2.5 cm) between back of cabinet and the wall.

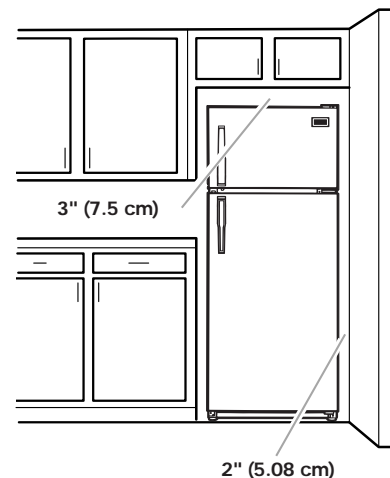

- If your refrigerator has an ice maker, make sure you leave some extra space at the back for the water line connections.
- If you are installing your refrigerator next to a fixed wall, leave 2 in. (5.08 cm) minimum on the hinge side (depending on your model) to allow for the door to swing open.
- Level the refrigerator (See "Door Closing and Alignment").

NOTE: Do not install the refrigerator near an oven, radiator, or other heat source, nor in a location where the temperature will fall below 40° F (5° C).

Electrical Requirements

⚠ WARNING



Electrical Shock Hazard

Plug into a grounded 3 prong outlet.

Do not remove ground prong.

Do not use an adapter.

Do not use an extension cord.

Failure to follow these instructions can result in death, fire, or electrical shock.

Before you move your refrigerator into its final location, it is important to make sure you have the proper electrical connection:

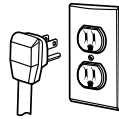

Recommended grounding method

A 115 Volt, 60 Hz., AC only 15 or 20 ampere fused, grounded electrical supply is required. It is recommended that a separate circuit serving only your refrigerator be provided. Use an outlet that cannot be turned off by a switch. Do not use an extension cord.

NOTE: Before performing any type of installation, cleaning, or removing a light bulb, turn the control, (Thermostat, Refrigerator or Freezer Control depending on the model) to OFF and then disconnect the refrigerator from the electrical source. When you are finished, reconnect the refrigerator to the electrical source and reset the control (Thermostat, Refrigerator or Freezer Control depending on the model) to the desired setting.

Connecting the Refrigerator to a Water Source

Read all directions carefully before you begin.

IMPORTANT:

- If operating the refrigerator before installing the water connection, turn ice maker to the OFF position to prevent operation without water.
- All installations must be in accordance with local plumbing code requirements.
- Use copper tubing and check for leaks.
- Install copper tubing only in areas where temperatures will remain above freezing.
- It may take up to 24 hours for your ice maker to begin producing ice.

Tools required:

- Standard screwdriver
- $\frac{7}{16}$ in. and $\frac{1}{2}$ in. open-end wrenches or two adjustable wrenches
- $\frac{1}{4}$ in. nut driver
- $\frac{1}{4}$ in. drill bit
- Hand drill or electric drill (properly grounded)

NOTE: Your refrigerator dealer has a kit available with a $\frac{1}{4}$ in. (6.35 mm) saddle-type shut-off valve, a union, and copper tubing. Before purchasing, make sure a saddle-type valve complies with your local plumbing codes. Do not use a piercing-type or $\frac{3}{16}$ in. (4.76 mm) saddle valve which reduces water flow and clogs more easily.

Cold Water Supply

The ice maker water valve contains a flow washer which is used as a water pressure regulator. The ice maker needs to be connected to a cold water line with water pressure between 30 and 120 psi. If a problem occurs, call your utility company.

Connecting to water line:

1. Unplug refrigerator or disconnect power.
2. Turn OFF main water supply. Turn ON nearest faucet long enough to clear line of water.
3. Find a $\frac{1}{2}$ in. (1.27 mm) to $1\frac{1}{4}$ in. (3.18 cm) vertical COLD water pipe near the refrigerator.

NOTE: Horizontal pipe will work, but the following procedure must be followed: Drill on the top side of the pipe, not the bottom. This will help keep water away from the drill. This also keeps normal sediment from collecting in the valve.

4. To determine the length of copper tubing you will need, measure from connection on lower left rear of refrigerator to water pipe. Add 7 feet (2.1 m) to allow for moving refrigerator for cleaning. Use $\frac{1}{4}$ in. (6.35 mm) O.D. (outside diameter) copper tubing. Be sure both ends of copper tubing are cut square.
5. Using a grounded drill, drill a $\frac{1}{4}$ in. (6.35 mm) hole in the cold water pipe you have selected.

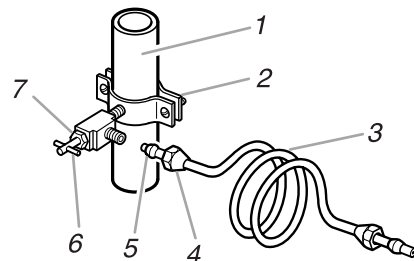

1. Cold Water Pipe
2. Pipe Clamp
3. Copper Tubing
4. Compression Nut
5. Compression Sleeve
6. Shut-Off Valve
7. Packing Nut

6. Fasten shut-off valve to cold water pipe with pipe clamp. Be sure outlet end is solidly in the $\frac{1}{4}$ in. (6.35 mm) drilled hole in the water pipe and that washer is under the pipe clamp. Tighten packing nut. Tighten the pipe clamp screws carefully and evenly so washer makes a watertight seal. Do not overtighten or you may crush the copper tubing, especially if soft (coiled) copper tubing is used. Now you are ready to connect the copper tubing.

7. Slip compression sleeve and compression nut on copper tubing as shown. Insert end of tubing into outlet end squarely as far as it will go. Screw compression nut onto outlet end with adjustable wrench. Do not overtighten.
8. Place the free end of the tubing into a container or sink, and turn ON main water supply and flush out tubing until water is clear. Turn OFF shut-off valve on the water pipe. Coil copper tubing.

Connecting to refrigerator:

NOTE: The first step for connecting the water line to your refrigerator is different depending on the type of water valve provided with your refrigerator. See the diagrams below to determine the style of valve you have. (On kit models, assemble water valve to refrigerator per kit instructions.)

1. **For Style 1**, disconnect the tube clamp on the back of the product and insert the copper tubing through the clamp, as shown. Remove the tape label from the valve inlet and insert copper tubing until it bottoms out (approximately ¾ in. [1.9 cm]). Tighten nut by hand as much as possible; then turn the nut an additional ½ turn using a wrench. Do not overtighten. Re-attach the tube clamp and tube to the back of the cabinet. Skip to Step 2.

For Style 2, disconnect the tube clamp on the back of the product and insert copper tubing through the clamp as shown. Attach the copper tube to the valve inlet using a compression nut and sleeve as shown. Tighten the compression nut. Do not overtighten. Re-attach the tube clamp and tube to the back of the cabinet. Move to Step 2.

2. **Turn shut-off valve ON. Check For Leaks.** Tighten any connections (including connections at the valve) or nuts that leak.

Style 1

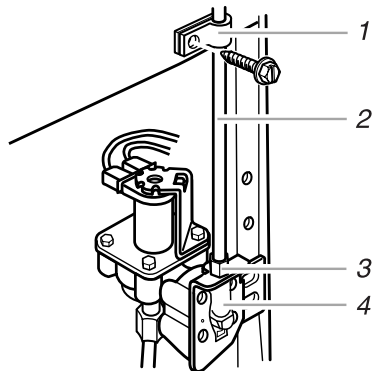

1. Tube Clamp
2. Copper Tubing
3. Compression Nut
4. Valve Inlet

Style 2

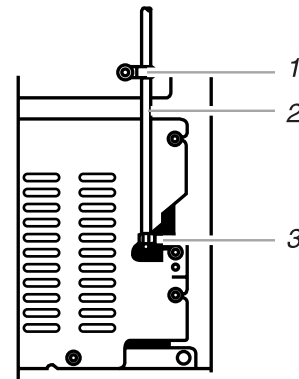

1. Tube Clamp
2. Copper Tubing
3. Compression Nut

3. The ice maker is equipped with a built-in water strainer. If local water conditions require periodic cleaning or a well is your source of water supply, a second water strainer should be installed in the ¼ in. (6.35 mm) water line. Obtain a water strainer from your nearest appliance dealer. Install at either tube connection.
4. Plug in refrigerator or reconnect power.

Refrigerator Doors: Removing, Reversing (optional) and Replacing

TOOLS NEEDED: 5/16 in. hex-head socket wrench, No. 2 Phillips screwdriver, flat-head screwdriver, 5/16 in. open-end wrench, flat 2 in. putty knife.

IMPORTANT: Before you begin, turn the refrigerator control OFF, unplug refrigerator or disconnect power. Remove food from doors.

Door Removal & Replacement

Top Hinge

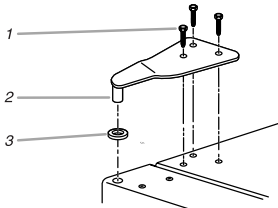

1. 5/16" Hex-Head Hinge Screws
2. Top Hinge
3. Spacer

Center Hinge

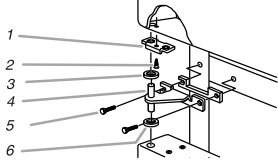

1. Door Stop
2. Door Stop Screw
3. Spacer
4. Center Hinge
5. 5/16" Hex-Head Hinge Screws
6. Spacer

Bottom Hinge

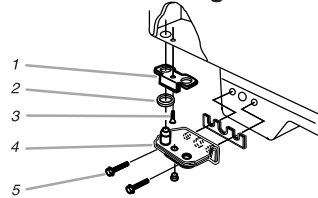

1. Door Stop
2. Spacer
3. Door Stop Screw
4. Bottom Hinge
5. 5/16" Hex-Head Hinge Screws

Door Swing Reversal (optional)

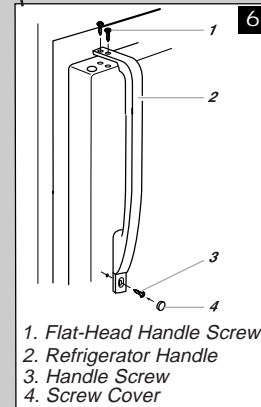
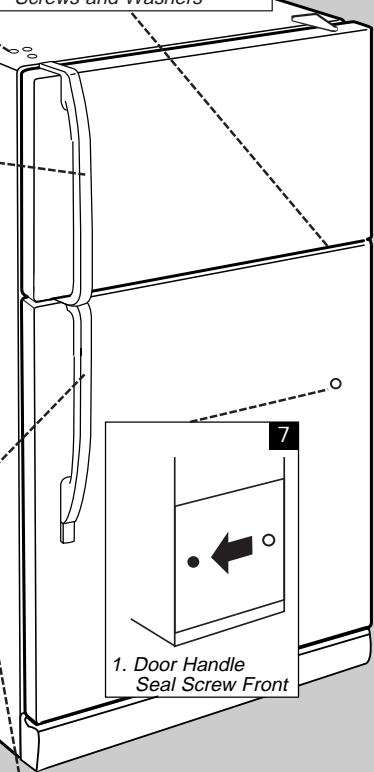
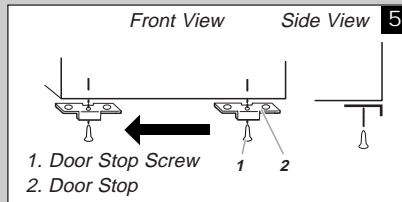
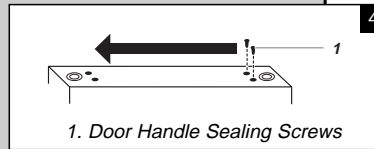
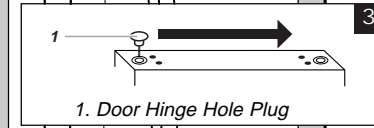
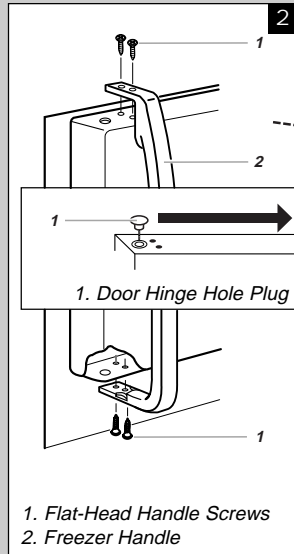
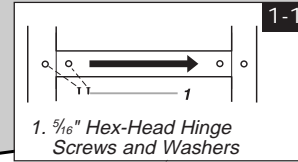

Door and hinge removal

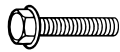

5/16 in. Hex-Head Hinge Screw

1. Unplug refrigerator or disconnect power.
2. Keep both doors closed until you are ready to lift them free from the cabinet.
NOTE: Provide additional support for the doors while the hinges are being moved. Do not depend on the door magnets to hold the doors in place while you are working.
3. Remove the parts for the top hinge as shown in Top Hinge graphic.
4. Lift the freezer door free from the cabinet.
5. Remove the parts for the center hinge as shown in the Center Hinge graphic.
6. Lift the refrigerator door free from the cabinet.
7. Remove the parts for the bottom hinge as shown in the Bottom Hinge graphic.

IMPORTANT: If you want to reverse your doors so that they open in the opposite direction, follow these steps. If you are not reversing the doors, see "Door and Hinge Replacement."

Door reversal (optional)



Door Stop Screw



Door Handle Sealing Screw



Flat-Head Handle Screw



Door Handle Seal Screw Front



Door Hinge Hole Plug



Cabinet Hinge Hole Plug



Door Handle Screw Cover



Round-Head Handle Screw

Cabinet

1. Remove 5/16 in. hex-head hinge screws from handle side and move them to opposite side (see Graphic 1-1).
2. Remove cabinet hinge hole plugs from cabinet top and move them to opposite side hinge holes as shown (see Graphic 1-2).

Freezer door

1. Remove freezer handle assembly as shown. Keep all parts together (see Graphic 2).
2. Remove door hinge hole plug. Move to opposite side as shown (see Graphic 3).
3. Remove door handle sealing screws. Move to opposite side of freezer door as shown (see Graphic 4).
4. Remove door stop. Move to opposite side of freezer door as shown (see Graphic 5).
5. Position freezer handle on opposite side of freezer door. Assemble handle on door as shown (see Graphic 2).
6. Tighten all screws. Set aside door until hinges and refrigerator compartment door are in place.

Refrigerator door

1. Remove the screw cover (see Graphic 6).
2. Remove refrigerator handle assembly as shown. Keep all parts together (see Graphic 6).
3. Remove door hinge hole plug from refrigerator door. Move to opposite side hinge hole as shown (see Graphic 3).

4. Remove door handle sealing screws. Move to opposite side of refrigerator door as shown (see Graphic 4).
5. Remove door handle seal screw front. Move to opposite side of refrigerator door as shown (see Graphic 7).
6. Remove door stop. Move to opposite side of refrigerator door as shown (see Graphic 5).
7. Position refrigerator handle on opposite side of the refrigerator door as shown (see Graphic 6). Drive top two screws in handle first. Align lower portion of handle and drive bottom screw.
8. Replace screw cover (see Graphic 6).
9. Tighten all screws. Set aside refrigerator door until bottom hinge is installed on product.

Door and hinge replacement

Note: Graphic may be reversed if door swing is reversed.

1. Replace the parts for the bottom hinge as shown. Tighten screws.
2. Replace the refrigerator door.
NOTE: Provide additional support for the doors while the hinges are being moved. Do not depend on the door magnets to hold the doors in place while you are working.
3. Assemble the parts for the center hinge as shown and tighten all screws (see Center Hinge graphic).
4. Replace the freezer door.
5. Assemble the parts the top hinge as shown (see Top Hinge graphic). Do not tighten screws completely.
6. Line up the doors so that the bottom of the freezer door aligns evenly with the top of the refrigerator door. Tighten all screws.

Final Steps

1. Check all holes to make sure that hole plugs and screws are in place.
2. Plug in refrigerator or reconnect power.
3. Reset the controls (see "Setting the Controls" section).

Door Closing and Alignment

Your refrigerator has two front adjustable rollers – one on the right and one on the left. If your refrigerator seems unsteady or you want the doors to close easier, adjust the refrigerator's tilt using the instructions below:

1. Roll out the refrigerator and use a level to check the floor at the back from side-to-side. If needed, use shims to level the back of the refrigerator if it is uneven. Roll the refrigerator back into place with the rear rollers on top of any shim(s) used so that the rear of the refrigerator is level.
2. With the rear already level and the refrigerator in place, use the bottom leveling screws to level the refrigerator from side-to-side. They are part of the front roller assemblies, which are found at the base of the refrigerator on either side.

NOTE: Having someone push against the top of the refrigerator takes some weight off the leveling screws and rollers. This makes it easier to adjust the screws.

Style 1

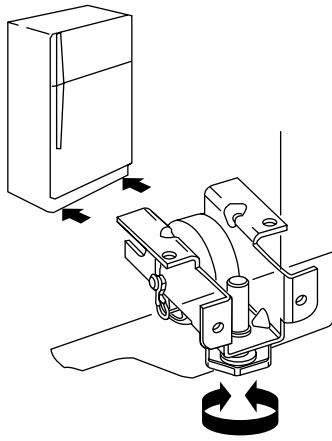

Style 2

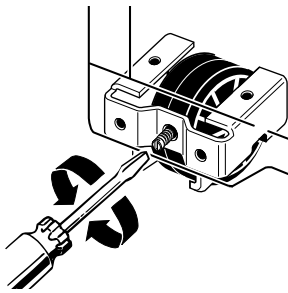

3. Depending on your model, to level your refrigerator you may either turn the screw clockwise to raise that side of the refrigerator or turn the screw counterclockwise to lower that side. Place a level on top of the refrigerator to check adjustments.
4. If the doors do not close on their own, you will need to raise the front of the refrigerator so it is slightly higher than the back. To do this, turn both leveling screws clockwise $\frac{1}{2}$ turn.
IMPORTANT: Be sure to turn both screws an equal amount or the refrigerator will no longer be level side-to-side.
5. Open doors and check if they close automatically. If not, repeat steps 3 and 4.
6. Using a level, check to see if the refrigerator is still level side-to-side. Readjust if necessary.

Understanding Sounds You May Hear

Your new refrigerator may make sounds that your old one didn't make. Because the sounds are new to you, you might be concerned about them. Most of the new sounds are normal. Hard surfaces, like the floor, walls, and cabinets, can make the sounds seem louder than they actually are. The following describes the kinds of sounds and what may be making them.

- If your product is equipped with an ice maker, you will hear a buzzing sound when the water valve opens to fill the ice maker for each cycle.
- The defrost timer will click when the automatic defrost cycle begins and ends. Also, the Thermostat Control (or Refrigerator Control depending on the model) will click when cycling on and off.
- Rattling noises may come from the flow of refrigerant, the water line, or items stored on top of the refrigerator.
- Your refrigerator is designed to run more efficiently to keep your food items at the desired temperature. The high

efficiency compressor may cause your new refrigerator to run longer than your old one, and you may hear a pulsating or high-pitched sound.

- Water dripping on the defrost heater during a defrost cycle may cause a sizzling sound.
- You may hear the evaporator fan motor circulating the air through the refrigerator and freezer compartments.
- As each cycle ends, you may hear a gurgling sound due to the refrigerant flowing in your refrigerator.
- Contraction and expansion of the inside walls may cause a popping noise.
- You may hear air being forced over the condenser by the condenser fan.
- You may hear water running into the drain pan during the defrost cycle.

USING YOUR REFRIGERATOR

Ensuring Proper Air Circulation

In order to ensure proper temperatures, you need to permit air flow between the refrigerator and freezer sections. As shown in the illustration, cool air enters through the bottom of the freezer section and moves up. Most of the air then flows through the freezer section vents and recirculates under the freezer floor. The rest of the air enters the refrigerator section through the top vent.

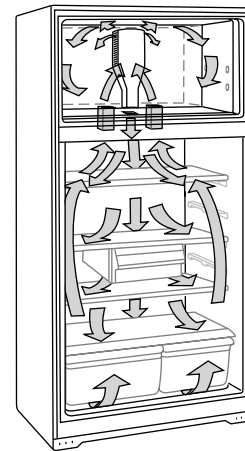

Do not block any of these vents with food packages. If the vents are blocked, airflow will be prevented and temperature and moisture problems may occur.

IMPORTANT: Because air circulates between both sections, any odors formed in one section will transfer to the other. You must thoroughly clean both sections to eliminate odors. To prevent odor transfer and drying out of food, wrap or cover foods tightly. (See the "Refrigerator Safety" section for details.)

Setting the Control(s)

For your convenience, the refrigerator controls are preset at the factory. Controls for the refrigerator and freezer are located in the top of the refrigerator section.

When you first install your refrigerator, make sure that the control(s) are still preset. The control(s) should be at the "mid-settings" as shown for each style of control.

Mid-setting "3"

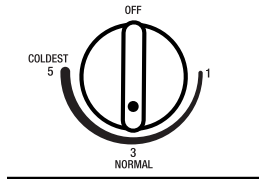

Mid-setting "3"

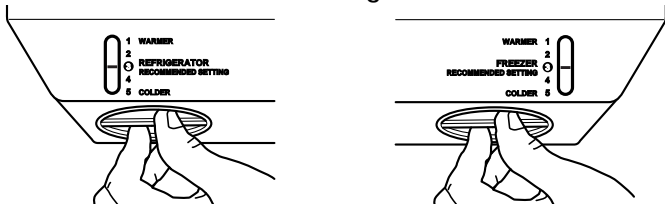

Mid-setting "4"

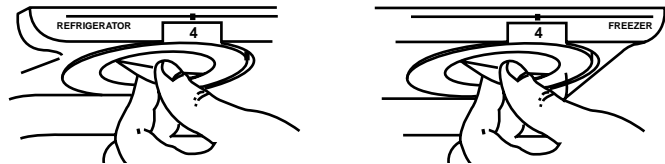

NOTE: To turn your refrigerator off, turn the refrigerator control to the word OFF or until the word OFF appears, as shown below. Your product will not cool when the refrigerator control is set to OFF.

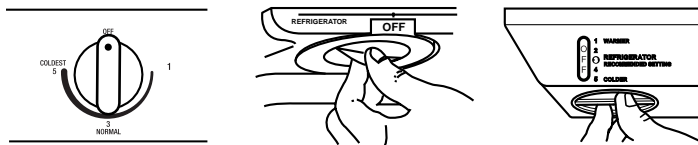

Give your refrigerator time to cool down completely before adding food. It is best to wait 24 hours before you put food into the refrigerator.

IMPORTANT: If you add food before the refrigerator has cooled completely, your food may spoil. **Turning the Refrigerator or Freezer Control(s) to a higher (colder) than recommended setting will not cool the compartments any faster.**

On models with two controls, the Freezer Control functions as an airflow director. Setting "1" will direct more of the cold air into the refrigerator section, while setting "5" (or "7" depending on your model) will direct more of the cold air into the freezer section. The cold air flows from the freezer compartment through the **top vent** into your fresh food section (see diagram in the "Ensuring Proper Air Circulation" section). On models with one control, the air-flow does not require adjustment.

Adjusting Control Settings

Give the refrigerator time to cool down completely before adding food. It is best to wait 24 hours before you put food into the refrigerator. The "mid-settings" indicated in the previous section should be correct for normal household refrigerator usage. The controls are set correctly when milk or juice is as cold as you like and when ice cream is firm.

For models with two controls:

The Refrigerator Control functions as the thermostat for the entire product (refrigerator and freezer sections). The higher the number setting, the longer the compressor will run to keep the temperature colder. The Freezer Control adjusts the cold air flow from the freezer to the refrigerator.

If you need to adjust temperatures in the refrigerator or freezer, start by adjusting the refrigerator first. Wait 24 hours after the refrigerator adjustment to check the freezer temperature. If it is too warm or too cold, then adjust the Freezer Control as well.

For models with a single control:

The Temperature Control functions as the thermostat for the entire product (refrigerator and freezer sections). The higher the number setting, the longer the compressor will run to keep the temperature colder.

Use the settings listed in the chart below as a guide. **Always remember to wait at least 24 hours between adjustments.**

CONDITION/REASON:	RECOMMENDED ADJUSTMENT:
REFRIGERATOR section too warm <ul style="list-style-type: none"> ■ Door opened often ■ Large amount of food added ■ Room temperature very warm 	Turn REFRIGERATOR Control or TEMPERATURE Control to next higher number, wait 24 hours, then re-check
<ul style="list-style-type: none"> ■ Blocked air stream 	Move items out of air stream
FREEZER section too warm/ice not made fast enough <ul style="list-style-type: none"> ■ Door opened often ■ Large amount of food added ■ Very cold room temperature (can't cycle often enough) ■ Heavy ice usage ■ Blocked air stream 	Turn FREEZER Control or TEMPERATURE Control to next higher number, wait 24 hours, then re-check
	Move items out of air stream

CONDITION/REASON:	RECOMMENDED ADJUSTMENT:
REFRIGERATOR section too cold <ul style="list-style-type: none"> ■ Controls not set correctly for your conditions ■ Blocked air stream 	Turn REFRIGERATOR Control or TEMPERATURE Control to next lower number, wait 24 hours, then re-check Move items out of air stream
FREEZER section too cold <ul style="list-style-type: none"> ■ Controls not set correctly for your conditions ■ Blocked air stream 	Turn FREEZER Control or TEMPERATURE Control to next lower number, wait 24 hours, then re-check Move items out of air stream

REFRIGERATOR FEATURES

Your model may have some or all of these features. Features that can be purchased separately as product accessories are labeled with the word "Accessory." Not all accessories will fit all models. If you are interested in purchasing one of the accessories, please call the toll-free number on the cover or in the "Assistance or Service" section.

Refrigerator Shelves

The shelves in your refrigerator are adjustable to match your individual storage needs.

Storing similar food items together in your refrigerator and adjusting the shelves to fit different heights of items will make finding the exact item you want easier. It will also reduce the amount of time the refrigerator door is open, and save energy.

To remove and replace a shelf:

1. Remove items from the shelf.
2. Slide the shelf straight out to the stop.
3. Depending on your model, lift back or front of the shelf past the stop. Slide shelf out the rest of the way.
4. Replace the shelf by sliding the back of the shelf into the track in the wall of the cabinet.
5. Guide the front of the shelf into the shelf track. Be sure to slide the shelf in all the way.

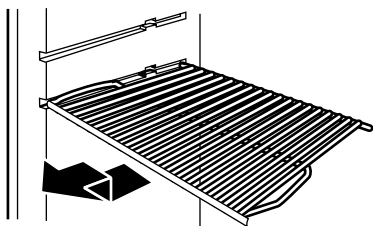

Meat Drawer and Cover

(on some models)

To remove and replace the meat drawer:

1. Slide meat drawer out to the stop.
2. Lift front of meat drawer with one hand while supporting bottom of drawer with other hand. Slide drawer out the rest of the way.
3. Replace the drawer by sliding it back in fully past the drawer stop.

To remove and replace the meat drawer cover:

1. Remove the meat drawer.
2. Push the cover back to release the rear clips from the shelf. Tilt the cover up at the front, and pull it forward.
3. Replace the meat drawer cover by fitting the notches and clips on underside of the cover over the rear and center crossbars on the shelf.
4. Lower cover into place and pull the cover forward to secure the rear clips onto the shelf.
5. Replace the meat drawer.

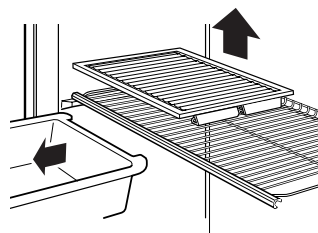

Meat storage guide

Store most meat in original wrapping as long as it is airtight and moisture-proof. Rewrap if necessary. See the following chart for storage times. When storing meat longer than the times given, freeze the meat.

- Fresh fish or shellfish..... use same day as purchased
- Chicken, ground beef, variety meats (liver) 1-2 days
- Cold cuts, steaks/roasts 3-5 days
- Cured meats 7-10 days
- Leftovers - Cover leftovers with plastic wrap, aluminum foil, or plastic containers with tight lids.

Crisper and Crisper Cover

(on some models)

To remove and replace the crisper(s):

1. Slide crisper(s) straight out to the stop. Lift the front and slide the crisper(s) out the rest of the way.
2. Replace the crisper(s) by sliding the crisper(s) in fully past the stop.

Style 1

To remove and replace the plastic cover:

1. Remove the crisper(s).
2. Lift the front of the cover to remove the cover support. Then lift the cover up and slide it out.

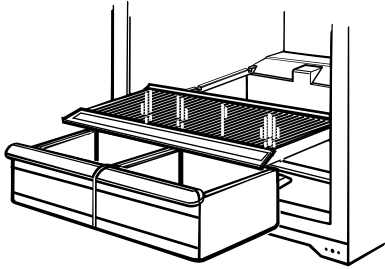

3. Replace the cover by fitting the cover tabs into lowest cabinet slots and pushing them in. Lower the front retainers into place.
4. Insert cover support (with the long tab toward the front) into the groove on the underside of the cover.

NOTE: If the support needs adjustment, turn base clockwise to raise or counter-clockwise to lower.

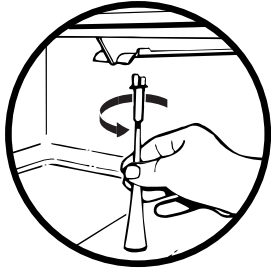

Style 2

To remove and replace the glass cover:

1. Pull the glass straight out.
2. Replace the glass by pushing it straight in.

Fruit and vegetable storage guide

Fruits: Wash, let dry and store in refrigerator in plastic bag or crisper. Do not wash or hull berries until they are ready to use. Sort and keep berries in original container in crisper, or store in a loosely closed paper bag on a refrigerator shelf.

Vegetables with skins: Place in plastic bags or plastic container and store in crisper.

Leafy vegetables: Wash in cold water, drain and trim or tear off bruised and discolored areas. Place in plastic bag or plastic container and store in crisper.

Utility or Egg Bin

(on some models -Accessory)

Depending on your model, you may have a one piece utility bin or a three piece egg bin. To use the three piece egg bin, remove the cover and place the eggs in the egg tray. Replace the cover and store on an interior shelf. If you prefer, you can remove the egg tray and place the entire carton of eggs in the bin. Replace the cover.

NOTE: Eggs should be stored in a covered container. If your model does not have an egg bin or covered utility bin, store eggs in their original container on an interior shelf.

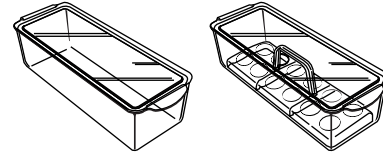

FREEZER FEATURES

Your model may have some or all of these features. Features that can be purchased separately as product accessories are labeled with the word "Accessory." Not all accessories will fit all models. If you are interested in purchasing one of the accessories, please call the toll-free number on the cover or in the "Assistance or Service" section.

Ice Maker

(on some models - Accessory)

There are two styles of ice makers:

- Normal (Style 1 - on left)
- Maximum Ice (Style 2 - on right)

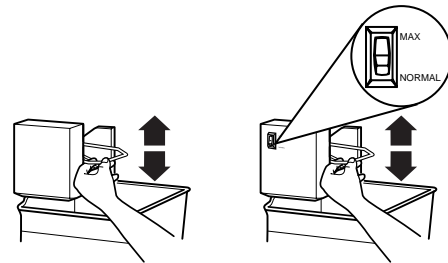

To turn the ice maker on:

The on/off switch for the ice maker is a wire shut-off arm located on the side of the ice maker. To turn the ice maker on, simply lower the wire shut-off arm.

NOTE: The ice maker will not make ice until the freezer is cold enough. Allow 24 hours to produce the first batch of ice. Discard the first three batches of ice produced.

To turn the ice maker off:

- Automatic turn off: As ice is made, the ice cubes will fill the ice storage bin, and the ice cubes will raise the wire shut-off arm to the OFF (arm up) position.
- Manual turn off: Lift the wire shut-off arm to the OFF (arm up) position and listen for the click to make sure the ice maker will not continue to operate.

To increase ice production rate:

- **Maximum Ice Production** (on some models): In maximum ice production, the ice maker should produce approximately 16 to 20 batches of ice in a 24-hour period. If your refrigerator has the maximum ice production feature, push the switch to MAX.
- **Normal Ice Production:** In normal ice production mode, the ice maker should produce approximately 8 to 12 batches of ice in a 24-hour period. If ice is not being made fast enough, turn the Freezer Control toward a higher (colder) number in half number steps. (For example, if the control is at 3, move it to between 3 and 4.) Wait 24 hours and, if necessary, gradually turn the Freezer Control to the highest setting, waiting 24 hours between each increase.

REMEMBER:

- Allow 24 hours to produce the first batch of ice.
- Discard the first three batches of ice produced to avoid impurities that may be flushed out of the system.
- The quality of your ice will be only as good as the quality of the water supplied to your ice maker.
- Avoid connecting the ice maker to a softened water supply. Water softener chemicals (such as salt) can damage parts of the ice maker and lead to poor quality ice. If a softened water supply cannot be avoided, make sure the water softener is operating properly and is well maintained.
- It is normal for the ice cubes to be attached at the corners. They will break apart easily.
- Do not force the wire shut-off arm up or down.
- Do not store anything on top of the ice maker or in the ice storage bin.

Freezer Shelf (on some models)

To remove and replace the freezer shelf:

1. Remove items from the shelf.
2. Lift back of shelf over stop and slide shelf straight out.
3. Replace the shelf by sliding the back of the shelf into the tracks on walls of cabinet.
4. Be sure to slide the shelf in all the way.

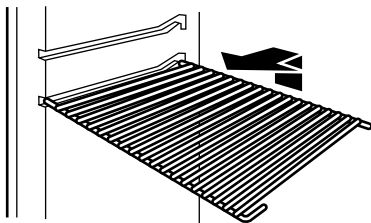

Frozen food storage guide

Storage times will vary according to the quality and type of food, the type of packaging or wrap used (should be airtight and moisture-proof), and the storage temperature. Seal the package or container securely to prevent taste and odor transfer throughout the product. Ice crystals inside a sealed package are normal. This simply means that moisture in the food and air inside the package have condensed, creating ice crystals.

Put no more unfrozen food into the freezer than will freeze within 24 hours (no more than 2-3 lb of food per cubic foot [907-1,350 g per L] of freezer space). Leave enough space in the freezer for air to circulate around packages. Be careful to leave enough room for the door to close tightly.

NOTE: For more information on preparing food for freezing, check a freezer guide or reliable cookbook.

DOOR FEATURES

Your model may have some or all of these features. Features that can be purchased separately as product accessories are labeled with the word "Accessory." Not all accessories will fit all models. If you are interested in purchasing one of the accessories, please call the toll-free number on the cover or in the "Assistance or Service" section.

Drop-in Door Rails

The door rails may be removed for easier cleaning.

To remove and replace the rails:

1. Remove all items from the shelf and pull straight up on each end of the rails.
2. Locate each end of the rail above the rail's pocket opening, and push the rail straight down until it stops.

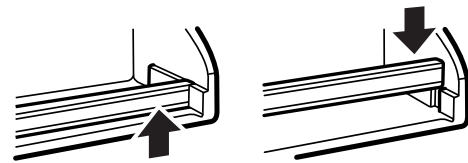

CARING FOR YOUR REFRIGERATOR

Cleaning Your Refrigerator

WARNING



Explosion Hazard

Use nonflammable cleaner.

Failure to do so can result in death, explosion, or fire.

Both the refrigerator and freezer sections defrost automatically. However, clean both sections about once a month to prevent odors from building up. Wipe up spills immediately.

To clean your refrigerator:

1. Unplug refrigerator or disconnect power.
2. Remove all removable parts from inside, such as shelves, crispers, etc.
3. Hand wash, rinse, and dry removable parts and interior surfaces thoroughly. Use a clean sponge or soft cloth and a mild detergent in warm water.

- Do not use abrasive or harsh cleaners such as window sprays, scouring cleansers, flammable fluids, cleaning waxes, concentrated detergents, bleaches or cleansers containing petroleum products on plastic parts interior and door liners or gaskets.
 - Do not use paper towels, scouring pads, or other harsh cleaning tools. These can scratch or damage materials.
 - To help remove odors, wash interior walls with a mixture of warm water and baking soda (2 tbs. to 1 qt. [26 g to .95 L] of water).
4. Wash stainless steel and painted metal exteriors with a clean sponge or soft cloth and a mild detergent in warm water. Do not use abrasive or harsh cleaners. Dry thoroughly with a soft cloth.
- For additional protection against damage to painted metal exteriors, apply appliance wax (or auto paste wax) with a clean, soft cloth. Do not wax plastic parts.
5. Clean the condenser coils regularly. Coils may need to be cleaned as often as every other month. This may help save energy.

Style 1 - Condenser coils behind base grille:

- Remove the base grille (see the "Base Grille" section).
- Use a vacuum with an extended attachment to clean the condenser coils when they are dusty or dirty.
- Replace the base grille when finished.

Style 2 - Condenser coils in back of the refrigerator:

- Pull refrigerator out away from the wall (see the "Unpacking Your Refrigerator" section).
- Vacuum coils when they are dusty or dirty.
- Roll refrigerator back into place. Make sure to leave 1 in. (2.5 cm) between the cabinet back and the wall.
- Check to see if the refrigerator is level.

6. Plug in refrigerator or reconnect power.

Changing the Light Bulb

NOTE: Not all appliance bulbs will fit your refrigerator. Be sure to replace the bulb with one of the same size, shape, and wattage.

To change the refrigerator light:

1. Unplug refrigerator or disconnect power.
2. Reach behind the Control Panel and unscrew the bulb.
3. Replace the bulb with a 40-watt appliance bulb.
4. Plug in refrigerator or reconnect power.

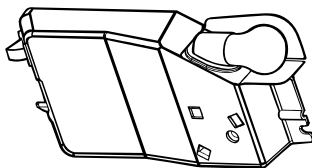

Power Interruptions

If the electricity in your house goes off, call the power company and ask how long it will be off.

1. If the power will be out for **24 hours or less**, keep both **refrigerator doors closed** to help food stay cold and frozen.
2. If the power will be out for **more than 24 hours**:
 - a) Remove all frozen food and store it in a frozen food locker.

OR

 - b) Place 2 lbs (907 g) of dry ice in the freezer for every cubic foot (28 L) of freezer space. This will keep the food frozen for two to four days.

OR

 - c) If neither a food locker nor dry ice is available, consume or can perishable food at once.

REMEMBER: A full freezer stays cold longer than a partially filled one. A freezer full of meat stays cold longer than a freezer full of baked goods. If you see that food contains ice crystals, it may be refrozen, although the quality and flavor may be affected. If the condition of the food is poor, dispose of it.

Vacation and Moving Care

Vacations

If you choose to leave the refrigerator on while you're away, use these steps to prepare your refrigerator before you leave.

1. Use up any perishables and freeze other items.
2. If your refrigerator has an automatic ice maker:
 - Raise wire shut-off arm to OFF (up) position or move the switch to the OFF (right) setting.
 - Shut off water supply to the ice maker.
3. Empty the ice bin.

If you choose to turn the refrigerator off before you leave, follow these steps.

1. Remove all food from the refrigerator.
2. If your refrigerator has an automatic ice maker:
 - Turn off the water supply to the ice maker at least one day ahead of time.
 - When the last load of ice drops, raise the wire shut-off arm to the OFF (up) position or move the switch to the OFF (right) setting.
3. Depending on your model, turn the Thermostat Control or Refrigerator Control to OFF. See the "Setting the Controls" section.
4. Clean refrigerator, wipe it, and dry well.
5. Tape rubber or wood blocks to the tops of both doors to prop them open far enough for air to get in. This stops odor and mold from building up.

Moving

When you are moving your refrigerator to a new home, follow these steps to prepare it for the move.

1. If your refrigerator has an automatic ice maker:
 - Turn off the water supply to the ice maker at least one day ahead of time.
 - Disconnect the water line from the back of the refrigerator.
 - When the last load of ice drops, raise the wire shut-off arm to the OFF (up) position or move the switch to the OFF (right) setting.

2. Remove all food from the refrigerator and pack all frozen food in dry ice.
3. Empty the ice bin.
4. Depending on your model, turn the Thermostat Control or Refrigerator Control to OFF. See the “Setting the Controls” section.
5. Unplug the refrigerator.
6. Empty water from the defrost pan.
7. Clean, wipe, and dry thoroughly.
8. Take out all removable parts, wrap them well, and tape them together so they don’t shift and rattle during the move.
9. Depending on the model, raise the front of the refrigerator so it rolls more easily OR screw in the leveling legs so they don’t scrape the floor. See the “Door Closing” or “Leveling Your Refrigerator” section.
10. Tape the doors shut and the power cord to the refrigerator cabinet.

When you get to your new home, put everything back and refer to the “Installing Your Refrigerator” section for preparation instructions. Also, if your refrigerator has an automatic ice maker, remember to reconnect the water supply to the refrigerator.

TROUBLESHOOTING

Try the solutions suggested here first in order to avoid the cost of an unnecessary service call.

Your refrigerator will not operate

- **Is the power supply cord unplugged?**
Firmly plug the cord into a live outlet with proper voltage.
- **Has a household fuse or circuit breaker tripped?**
Replace the fuse or reset the circuit.
- **Is the Refrigerator Control turned to the OFF position?**
Refer to the “Setting the Control(s)” section.
- **Is the refrigerator defrosting?**
Recheck to see if the refrigerator is operating in 30 minutes. Your refrigerator will regularly run an automatic defrost cycle.

The lights do not work

- **Is the power supply cord unplugged?**
Firmly plug the cord into a live outlet with proper voltage.
- **Is a light bulb loose in the socket?**
Turn the refrigerator control to OFF. Disconnect the refrigerator from the electrical supply. Gently remove the bulb and reinsert. Then reconnect the refrigerator to the electrical supply and reset the refrigerator control.
- **Has a light bulb burned out?**
Replace with an appliance bulb of the same wattage, size, and shape. See the “Changing the Light Bulb(s)” section.

There is water in the defrost drain pan

- **Is the refrigerator defrosting?**
The water will evaporate. It is normal for water to drip into the defrost pan.
- **Is it more humid than normal?**
Expect that the water in the defrost pan will take longer to evaporate. This is normal when it is hot or humid.

The motor seems to run too much

- **Is the room temperature hotter than normal?**
Expect the motor to run longer under warm conditions. At normal room temperatures, expect your motor to run about 40% to 80% of the time. Under warmer conditions, expect it to run even more of the time.
- **Has a large amount of food just been added to the refrigerator?**
Adding a large amount of food warms the refrigerator. It is normal for the motor to run longer in order to cool the refrigerator back down. See the “Refrigerator Features” section.
- **Are the doors opened often?**
Expect the motor to run longer when this occurs. In order to conserve energy, try to get everything you need out of the refrigerator at once, keep food organized so it is easy to find, and close the door as soon as the food is removed.
- **Is the control set correctly for the surrounding conditions?**
Refer to the “Setting the Control(s)” section.
- **Are the doors closed completely?**
Push the doors firmly shut. If they will not shut all the way, see “The doors will not close completely” later in this section.
- **Are the condenser coils dirty?**
This prevents air transfer and makes the motor work harder. Clean the condenser coils. Refer to the “Cleaning Your Refrigerator” section.

NOTE: Your new refrigerator will run longer than your old one due to its high efficiency motor.

The refrigerator seems to make too much noise

- **The sounds may be normal for your refrigerators.**
Refer to the “Understanding Sounds You May Hear” section.

The ice maker is not producing ice

- **Is the freezer temperature cold enough to produce ice?**
Wait 24 hours after hook-up for ice production. See the “Setting the Control(s)” section.
- **Is the wire shut-off arm in the OFF (arm up) position?**
Lower the wire shut-off arm to the ON (arm down) position. See the “Ice Maker Operation” section.
- **Is the water line shut-off valve to the refrigerator turned on?**
Turn on the water valve. See the “Connecting the Refrigerator to a Water Source” section.

- **Is an ice cube jammed in the ejector arm?**
Remove the ice from the ejector arm with a plastic utensil. Refer to the “Ice Maker Operation” section.
- **Does the ice maker mold have water in it or has no ice been produced?**
Check to see if your refrigerator has been connected to your home water supply and the supply shut-off valve is turned on. Refer to the “Connecting the Refrigerator to a Water Source” section.

NOTE: If not due to any of the above, there may be a problem with the water line. Call for service.

The ice maker is producing too little ice

- **Has the ice maker just been installed?**
Wait 72 hours for full ice production to begin. Once your refrigerator is cooled down, the ice maker should begin producing 70-120 cubes every 24 hours.
- **Has a large amount of ice just been removed?**
Allow 24 hours for ice maker to produce more ice.
- **Is the control set correctly?**
Refer to the “Setting the Control(s)” section.
- **Is the water shut-off valve turned completely on?**
Turn valve on fully. Refer to the “Connecting the Refrigerator to a Water Source” section.
- **Is there a water filter installed on the refrigerator? This filter may be clogged or installed incorrectly.**
First, check the filter installation instructions to ensure that the filter was installed correctly and is not clogged. If installation or clogging is not a problem, call a qualified person or a technician.

Off-taste or odor in the ice

- **Are the plumbing connections new, causing discolored or off-flavored ice?**
Discard the first few batches of ice.
- **Have the ice cubes been stored for too long?**
Throw old ice away and make a new supply.
- **Has food in the refrigerator been wrapped properly?**
Refer to the “Refrigerator Features” section.
- **Do the freezer and ice bin need to be cleaned?**
See the “Cleaning Your Refrigerator” section.
- **Does the water contain minerals (such as sulfur)?**
A filter may need to be installed to remove the minerals.

The divider between the two compartments is warm

The warmth is probably due to normal operation of the automatic exterior moisture control.

Temperature is too warm

- **Are the air vents blocked in either compartment? This prevents the movement of cold air from the freezer to the refrigerator.**
Remove any objects from in front of the air vents. Refer to “Ensuring Proper Air Circulation” for the location of air vents.
- **Are the door(s) opened often?**
Be aware that the refrigerator will warm when this occurs. In order to keep the refrigerator cool, try to get everything you need out of the refrigerator at once, keep food organized so it is easy to find, and close the door as soon as the food is removed.
- **Has a large amount of food just been added to the refrigerator or freezer?**
Adding a large amount of food warms the refrigerator. It can take several hours for the refrigerator to return to the normal temperature.
- **Is the control set correctly for the surrounding conditions?**
Refer to the “Setting the Control(s)” section.

There is interior moisture build-up

- **Are the air vents blocked in the refrigerator?**
Remove any objects from in front of the air vents. Refer to “Ensuring Proper Air Circulation” for the location of air vents.
- **Is the door opened often?**
To avoid humidity build-up, try to get everything you need out of the refrigerator at once, keep food organized so it is easy to find, and close the door as soon as the food is removed. (When the door is opened, humidity from the room air enters the refrigerator. The more often the door is opened, the faster humidity builds up, especially when the room itself is very humid.)
- **Is the room humid?**
It is normal for moisture to build up inside the refrigerator when the room air is humid.
- **Is the food packaged correctly?**
Check that all food is securely wrapped. If necessary, repackage food according to the guidelines in the “Refrigerator Features” section. Wipe off damp food containers before placing in the refrigerator.
- **Is the control set correctly for the surrounding conditions?**
Refer to the “Setting the Control(s)” section.
- **Was a self-defrost cycle completed?**
It is normal for droplets to form on the back wall after the refrigerator self-defrosts.

The doors are difficult to open

- **Are the gaskets dirty or sticky?**
Clean gaskets and the surface that they touch. Rub a thin coat of paraffin wax on the gaskets following cleaning.

The doors will not close completely

- **Are food packages blocking the door open?**
Rearrange containers so that they fit more tightly and take up less space.
- **Is the ice bin out of position?**
Push the ice bin in all the way.
- **Are the crisper cover, pans, shelves, bins, or baskets out of position?**
Put the crisper cover and all pans, shelves, bins, and baskets back into their correct positions. See the "Refrigerator Features" section for more information.
- **Are the gaskets sticking?**
Clean gaskets and the surface that they touch. Rub a thin coat of paraffin wax on the gaskets following cleaning.
- **Does the refrigerator wobble or seem unstable?**
Level the refrigerator. Refer to the "Door Closing and Alignment" section.
- **Were the doors removed during product installation and not properly replaced?**
Remove and replace the doors according to the "Refrigerator Doors: Removing, Reversing (optional) and Replacing" section, or call a qualified service technician.

ASSISTANCE OR SERVICE

Before calling for assistance or service, please check "Troubleshooting." It may save you the cost of a service call. If you still need help, follow the instructions below.

When calling, please know the purchase date and the complete model and serial number of your appliance. This information will help us to better respond to your request.

If you need replacement parts

If you need to order replacement parts, we recommend that you only use factory specified replacement parts. Factory specified replacement parts will fit right and work right because they are made with the same precision used to build every new KIRKLAND SIGNATURE™ appliance.

To locate factory specified replacement parts in your area, call our Consumer Assistance Center telephone number or your nearest designated service center.

In the U.S.A.

Call the Whirlpool Consumer Assistance Center toll free: **1-800-253-1301**.

Our consultants provide assistance with:

- Features and specifications on our full line of appliances.
- Installation information.
- Use and maintenance procedures.
- Accessory and repair parts sales.
- Specialized customer assistance (Spanish speaking, hearing impaired, limited vision, etc.).
- Referrals to local dealers, repair parts distributors, and service companies. Whirlpool designated service technicians are trained to fulfill the product warranty and provide after-warranty service, anywhere in the United States.

To locate the Whirlpool designated service company in your area, you can also look in your telephone directory Yellow Pages.

For further assistance

If you need further assistance, you can write to Whirlpool Corporation with any questions or concerns at:

Whirlpool Brand Home Appliance
Consumer Assistance Center
c/o Correspondence Dept.
for KIRKLAND SIGNATURE™ Products
2000 North M-63
Benton Harbor, MI 49022-2692

Please include a daytime phone number in your correspondence.

REFRIGERATOR WARRANTY

TWO-YEAR FULL WARRANTY ON REFRIGERATOR MANUFACTURED FOR COSTCO WHOLESALE CORPORATION BY WHIRLPOOL CORPORATION

For two years from the date of purchase, when this refrigerator (excluding the water filter) is operated and maintained according to instructions attached to or furnished with the product, Whirlpool Corporation will pay for factory specified parts and repair labor costs to correct defects in materials or workmanship. Service must be provided by a Whirlpool designated service company.

On models with water filter: 30 day limited warranty on water filter. For 30 days from the date of purchase, when this filter is operated and maintained according to instructions attached to or furnished with the product, Whirlpool Corporation will pay for replacement parts to correct defects in materials and workmanship.

FIVE-YEAR FULL WARRANTY ON SEALED REFRIGERATION SYSTEM

For five years from the date of purchase, when this refrigerator is operated and maintained according to instructions attached to or furnished with the product, Whirlpool Corporation will pay for factory specified parts and repair labor costs to correct defects in materials or workmanship in the sealed refrigeration system. These parts are: compressor, evaporator, condenser, dryer, and connecting tubing. Service must be provided by a Whirlpool designated service company.

Whirlpool Corporation will not pay for:

1. Service calls to correct the installation of your refrigerator, to instruct you how to use your refrigerator, to replace house fuses or correct house wiring or plumbing, to replace light bulbs, or replacement water filters other than as noted above.
 2. Repairs when your refrigerator is used in other than normal, single-family household use.
 3. Pickup and delivery. Your refrigerator is designed to be repaired in the home.
 4. Damage resulting from accident, alteration, misuse, abuse, fire, flood, improper installation, acts of God, or use of products not approved by Whirlpool Corporation.
 5. Any food loss due to product failure.
 6. Repairs to parts or systems resulting from unauthorized modifications made to the appliance.
 7. Replacement parts or repair labor costs for units operated outside the United States.
-

WHIRLPOOL CORPORATION SHALL NOT BE LIABLE FOR INCIDENTAL OR CONSEQUENTIAL DAMAGES

Some states do not allow the exclusion or limitation of incidental or consequential damages, so this exclusion or limitation may not apply to you. This warranty gives you specific legal rights, and you may also have other rights which vary from state to state.

Outside the 50 United States, this warranty does not apply. Contact your authorized Whirlpool dealer to determine if another warranty applies.

Whirlpool Corporation is responsible for providing any in-warranty service covered in this warranty. If you need service, first see the "Troubleshooting" section of this book. After checking "Troubleshooting," additional help can be found by checking the "Assistance or Service" section or by calling the Whirlpool Consumer Assistance Center, 1-800-253-1301 (toll-free), from anywhere in the U.S.A. or writing: Whirlpool Brand Home Appliance, Consumer Assistance Center, c/o Correspondence Dept. for KIRKLAND SIGNATURE™ Products, 2000 North M-63, Benton Harbor, MI 49022-2692

11/99

Keep this book and your sales slip together for future reference. You must provide proof of purchase or installation date for in-warranty service.

Write down the following information about your refrigerator to better help you obtain assistance or service if you ever need it. You will need to know your complete model number and serial number. You can find this information on the model and serial number label located on the inside wall of the refrigerator compartment.

Dealer name _____
Address _____
Phone number _____
Model number _____
Serial number _____
Purchase date _____

Notes

