

Operation overview

Make and answer calls

- Make a call** Dial the number > Press OR dial the number > Take the handset off the hook
- Answer a call** Take the handset off the hook OR press

Transfer call

- Blind transfer** When call is ringing, press > Dial the number > Press
- Attended transfer** Press > Dial the number > Press > Announce the call > Hang up the handset

Forward call

- Press > Press 2 Call Features > 1 Call Forwarding >
- Always** 1 Forward All > 2 Target when Forwarding > Enter target phone number > 1 Enable Forwarding > Choose Yes
- When busy** 2 Forward when Busy > 2 Target when Forwarding > Enter target phone number > 1 Enable Forwarding > Choose Yes
- On timeout** 3 Forward after Timeout > 2 Target when Forwarding > Enter target phone number > 1 Enable Forwarding > Choose Yes > 3 Call Forwarding time > Enter time in seconds

Hold and resume

- Hold call** Press
- Resume call** Press again

Conference

- Establish** Call the first participant > Press > Call the second participant > Drag and drop the second call into context area to start conf.
- Disconnect** Drag and drop calls out of the context area to put the two participants on hold

Mailbox

- Retrieve new messages** Press

Phone information and utilities

- IP address** Press > 5 Maintenance > 1 System Info to show IP address and firmware version
- Access web interface** Enter your phone's IP address in the web browser's address bar and press ENTER
- Reboot** Press > 5 Maintenance > 3 Reboot

Your specialist retailer:

Quick Start Guide snom 870

Delivery content

1. Base unit
2. Footstand with bracket + 2 screws
3. Handset
4. Handset cable
5. Ethernet cable
6. Power supply
7. Quick Start Guide
8. GNU General Public License



This is the Quick Start Guide to the installation and operation of the phone. It contains information about setting up the phone and a phone and operation overview. Further documentation is available in the snom knowledge base: <http://wiki.snom.com>

Copyright

© 2009 snom technology Aktiengesellschaft (v.1.07)

All Rights Reserved. This document is supplied by snom technology AG. No part of this document may be reproduced, republished or retransmitted in any form or by any means whatsoever, whether electronically or mechanically, including, but not limited to, by way of photocopying, recording, information recording or through retrieval systems, without the express written permission of snom technology AG.

snom technology AG reserves the right to revise this document and make changes at any time and without the obligation to notify any person and/or entity of such revisions and/or changes. Product specifications contained in this document are subject to change without notice.

TeamSpirit ® VoiceEngine is Copyright © 1995-2009, SPIRIT

Setting up the phone

1. Check contents of the package for completeness.
2. Connect the long end of the handset cord to the connector on the back of the base unit. Connect the short end of the handset cord to the handset. Place the cord in the cable guide on the right side of the phone's back .

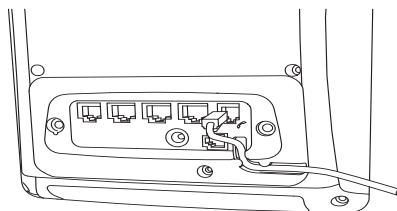

3. Attach the footstand with the bracket and the two screws. Choose between horizontal (55° inclination) or vertical (33° inclination) placement.

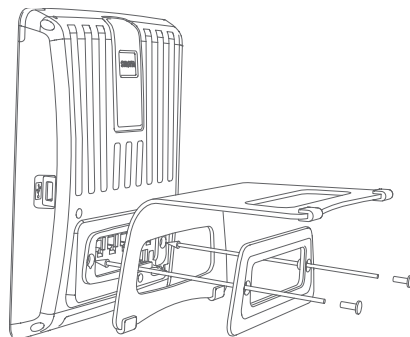

4. Plug the other cables into the jacks labelled as follows:

NOTE: Wrong power supplies may cause damage to the phone. Use only the power supply included in the package.

- (a) Ethernet/POE cable to "NET" to connect to your internal network
- (b) Power supply (if PoE is not used) to "5V DC"
- (c) PC to "PC" via second ethernet cable (not included)
- (d) Headset to the headset connector via headset cable (not included)

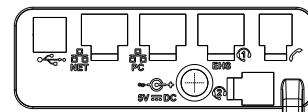

5. Place the phone on an even, horizontal surface.

The phone is installed and will start the initialization. The initialization process depends on your network environment and configuration. For further information contact your administrator or download the user manual from our web page www.snom.com.

Phone overview



- | | |
|---------------------------------------|--|
| 1. Call indication LED | Indicates incoming calls, calls on hold, missed calls |
| 2. Touchscreen | for intuitive navigation and phone use. Shows information and activity of the phone |
| a. Context area | Current phone activity (in call, in conference, etc.) |
| b. Call appearances | Line info (active calls, calls on hold, free lines, etc.) |
| 3. Navigation keys | Use to navigate in the display menus and confirm & cancel actions. |
| 4. MWI key with LED | Indicates messages on mailbox and missed calls. |
| 5. Alphanumeric keys | Enter numbers, letters and special characters |
| 6. Preprogrammed function keys | Press respective key to turn on DND, enter directory, main menu, transfer calls, and put calls on hold |
| 7. Audio control keys | Use to change the volume and to switch between handset, handsfree, and headset mode |