



Industrial Measuring Microscope STM505 series



User's manual

M.R.C.LTD. P.O.B. 1684, TEL-AVIV 61016, ISRAEL

TEL: 972-3-5593105, 972-3-5595252 FAX: 972-3-5594529

CONTENTS

PREFACE	1
1. Outline	1
1.1 Description	1
1.2 Specification	1
2. Installation and setup	2
2.1 Package Contents	2
2.2 Installation Site	2
2.3 Setting-up	2
2.4 Checking and Adjustment	3
3. Measurement	6
3.1 Preparation for Measurement	6
3.2 Measurement	8
4. Maintenance	9
4.1 Cleaning and Lubrication	9
4.2 Inspection	10
4.3 Replacing Consumable parts	11

PREFACE

Thank you for purchasing our industrial measuring microscope. This User's Manual explains the hardware operation of the instrument and the precautions to be observed during operation. To obtain the best possible performance and longest service life from your Industrial Microscope, please read this user's manual thoroughly.

1. Outline

1.1 Description

The industrial measuring microscope is a wide range of application from shop-floor inspection, measurement of tools and machined parts, to precision measurement of test tools in a measuring room. It is designed with angle dial, also can measure angle.

The Industrial Microscope is easy-to-use and compactly laid out. It consists of objective, eyepiece, XY stage, angle dial, reflected illuminator, transmitted illuminator power and so on.

1. Eyepiece
2. Diopter adjustment ring
3. Eyepiece mount
4. Optical tube
5. Reflected illuminator
6. Objective
7. XY stage
8. Angle dial
9. Angle dial clamp screw
10. Vernier
11. Vernier clamp screw
12. Focusing knob
13. Control panel
14. Power panel

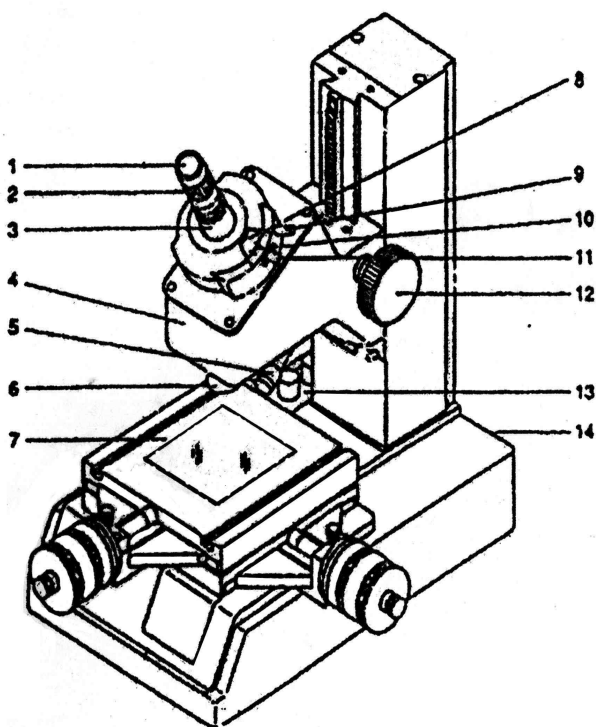

1.2 Specification

(1) Graduation:

Micrometer head: 0.0001" (0.00254mm)

Angle dial: 1°

Vernier: 6'

(2) XY stage feeding range:

Without gauge block: 25×25mm (1" ×1")

With gauge block: 50×50mm (2" ×2")

(3)Eyepiece:

Magnification: 15X

Field number: 13

(4)Objective

Magnification: 2X

Working distance: 67mm

2 Installation and Setup

2.1 Package Contents

Name	Amount
1.objective(2 ^X)	1
2.Eyepiece(15 ^X)	1
3.Cross-hair reticule	1
4.Reflected illuminator	1
5.Micrometer Head	2
6.Reticle setting screw	1
7.Spare bulb(24v)	1
8.Spare fuse(0.5A)	1
9.Power cord	1
10.Grounding wire	1
11.User's Manual	1

2.2 Installation Site

Install the Industrial Microscope in a place which is free from vibration and dust.

2.3 Setting-up

1. Install the Micrometer Head on the XY stage.

Loosen the hex-socket head screw on the bracket. If using a Micrometer Head with a fitting hole in the stem, inset the stem so the hole is aligned with the clamp screw. If this puts the scale on the Micrometer Head in a poor position for viewing the zero graduation, adjust the scale position by turning the Micrometer Head sleeve. Then, tighten the hex-socket head screw with the stem in place.

2. Connect the reflected illuminator cable to the connector on the power panel, which is at the back of the Industrial Microscope.

3. Set the voltage selector plug to the supply voltage. Turn the fuse holder to remove the fuse. Pull out the selector plug, insert the selector plug so that the supply voltage can be seen

through the notch. Insert the fuse into the holder and attach the holder to the voltage selector plug.

4. Turn off the illuminator select switch knob, and connect the power cord to the power panel.

Checking and Adjustment

2.4.1 Checking the reticle position against the XY stage movement direction

1. Place a small work-piece on the stage glass and bring it into focus.
2. Turn the Micrometer Heads to align an edge of the work-piece with the center of the cross-hair.
3. while turning the Micrometer Head to move the work-piece left and right, turn the angle dial so that the horizontal cross-hair is oriented to coincide with the direction of the stage movement.

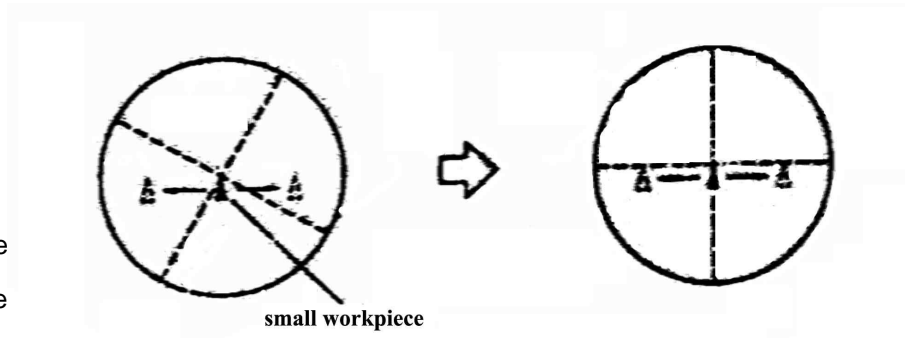

4. Loosen the vernier scale position by referring to "2.4.3(1) Adjusting the reticle to the XY stage movement direction."

2.4.2 Checking the centering of the reticle

To perform dimensional measurement by turning the angle dial or after replacing the reticle, align the cross-hair with the center of rotation of the angle dial, as follows.

1. Place a small workpiece on the stage glass and bring it into focus.
2. Turn the Micrometer Heads to align an edge of the workpiece with the center of the cross-hair.
3. Turn the angle dial 180°. Make sure the edge of the workpiece remains within 3 μ m of the cross-hair.

If it is not within 3 μ m, adjust the center of the reticle by referring to "2.4.3(2) Centering the reticle".

2.4.3 Adjusting the reticle

(1) Adjusting the reticle with the XY stage moving direction

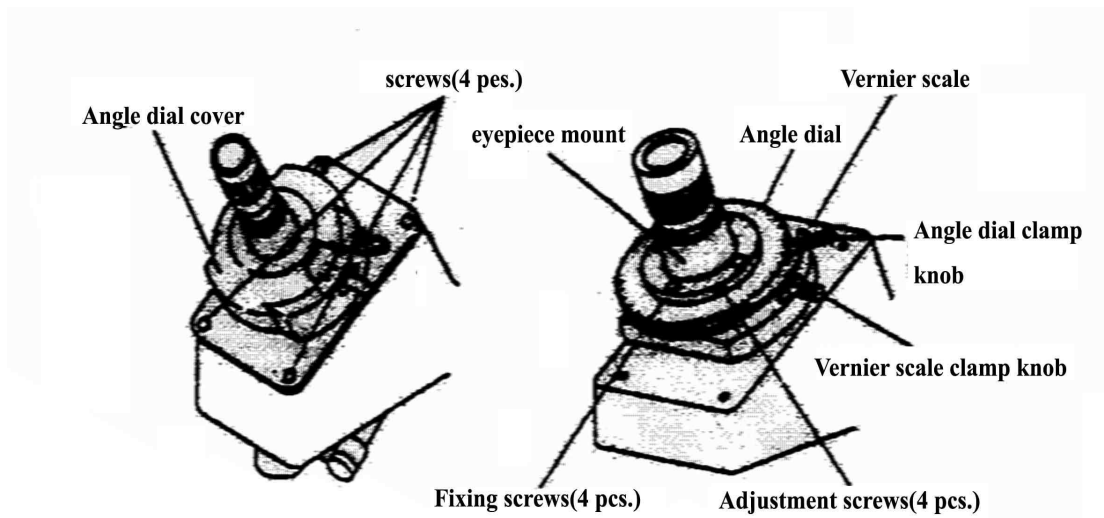

1. Remove the clamp knobs from the angle dial and vernier scale.
2. Remove the four screws from the angle dial cover and remove the cover.
3. Screw-in the clamp knobs on the angle dial and vernier scale.
4. Approximately center the vernier scale in the adjustable range. Then secure it with the clamp knob.
5. Align the 0° graduation of the angle dial with that on the vernier scale. Then, secure the angle dial with the clamp knob.
6. Loosen both the adjustment screws and fixing screws(4 pcs.each) so that the eyepiece mount can be moved manually.
7. While looking into the eyepiece, adjust the position of the eyepiece mount so that the horizontal cross-hair is oriented to coincide with the direction of the stage movement.
8. Temporarily secure the eyepiece mount by lightly tightening the fixing screws.
9. Centering the reticle as described in "(2) Centering the reticle" below. Firmly secure the eyepiece mount by fully tightening the fixing screws.
10. Remove the clamp knobs from the angle dial and vernier scale.
11. Replace the angle dial cover and secure it to the optical tube with the four screws.
12. Screw-in the clamp knobs on the angle dial and vernier scale.

(2) Centering the reticle

1. Place a small workpiece on the stage glass. Turn the Micrometer Heads to align an edge of the workpiece with the center of the cross-hair.
2. Rotate the angle scale disc 180° and read the displacement between the edge of the workpiece and the center of the cross-hair.
3. Remove the four screws from the angle dial cover and dismount it Slightly loosen the four fixing screws.
4. Adjust the eyepiece mount position with the four adjustment screws to minimize the displacement between the edge of the work-piece and the center of the cross-hair. Centering is easily performed by moving the eyepiece mount by half the displacement in both X and Y directions. Two pairs of adjustment screws are located at the opposite sides(for adjusting the X and Y displacements).Adjust the screws in pairs. Loosen one on one side, and then tighten its counterpart on the other side to adjust the displacement.
5. Turn the Micrometer Heads to align an edge of the work-piece with the center of the cross-hair. Rotate the angle dial 180° and check the displacement.
6. Repeat steps 1,2,4,5 until the displacement falls within 3.
7. Confirm that the four adjustment screws are fully tightened.
8. Tighten the four fixing screws and replace the angle deal cover.

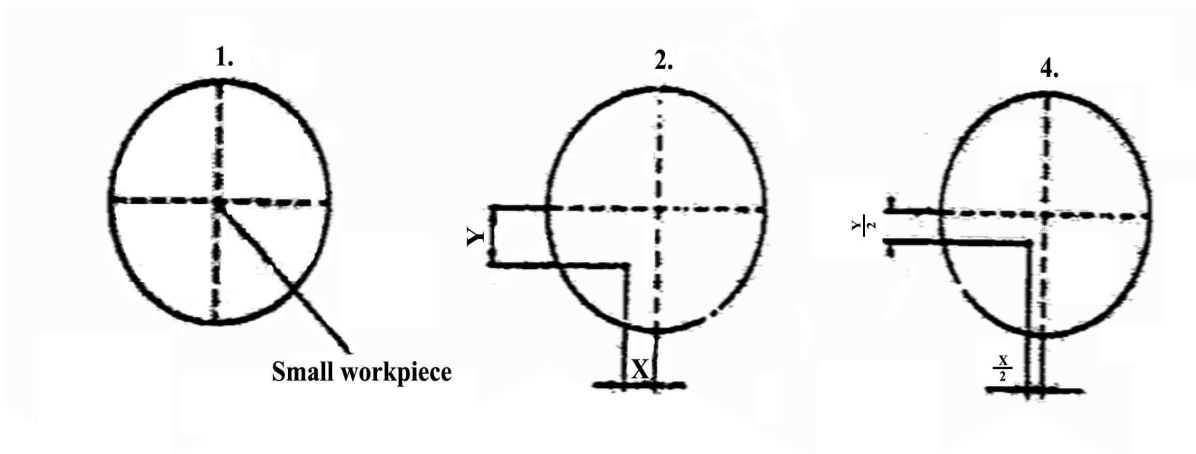

3.1.1 Precautions for measurement

1. Installation site

When selecting an installation site, keep in mind vibration, dust, and humidity considerations. Vibration can affect measuring accuracy. Dust and humidity can impair optical parts, such as the objective and prism, as well as the XY stage and moving parts.

2. Precaution

If focusing, making measurements, or mounting workpieces, take the surrounding conditions into account. Be careful not to bump the objective, stage glass, etc.

3. Objective and Eyepiece

The supplied objective and eyepiece were finely adjusted before shipment. To maintain performance and accuracy, handle them with care and do not disassemble. Do not allow the surface of the lens to be scratched or to be exposed to machine oil. If the lens is soiled, clean it as described in "4.1(3)".

4. Stage glass

Since workpieces are mounted on it, the stage glass is likely to be scratched or even severely damaged. Dust the workpiece before placing it on the stage glass. Exercise care so as not to bump the stage glass with the workpiece. Do not slide the workpiece on the stage.

3.1.2 Illumination modes

The Industrial Microscope supports the following illumination modes. Select the appropriate illumination mode according to your application.

(1) Transmitted illumination

The transmitted illumination generates a contour image of the workpiece, and is suited for measurement and inspection of workpiece contours. The illuminator is equipped with a green filter.

(2) Reflected illumination

Reflected illumination shows the surfaces of a workpiece, and is used in observation and inspection of workpiece surfaces. Adjust the angle and orientation of this illuminator so the workpiece surface can be observed under optimum conditions.

The optional twin-bulb reflected illumination unit can be used if necessary.

(3) Simultaneous use of transmitted and reflected illuminations

Both the contour and surface of the workpiece can be observed simultaneously.

To switch these illumination modes, use the illuminator select switch.

3.1.3 Adjusting the diopter

While looking into the eyepiece, turn the diopter adjustment ring until the reticle can be seen sharply.

3.1.4 Bringing the measuring surface into focus

Bring the measuring surface into focus by moving the optical tube up and down with the

focusing knob. Look into the eyepiece to make sure the cross-hairs are kept in ocular focus during this focusing operation.

If moving the optical tube, be careful, especially if the workpiece is stepped or is, not to bump the workpiece.

3.1.5 Positioning the workpiece

Align the measuring direction of the workpiece with that of the stage traverse.

Follow the procedure in "2.4.3(1) Adjusting the reticle with the XY stage moving direction".

After making the above adjustment, confirm that alignment is correct by moving the XY stage as shown below.

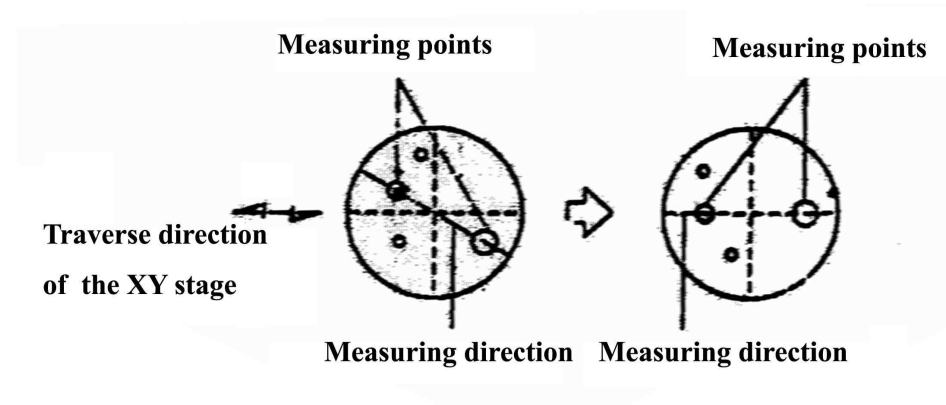

the reading from the Micrometer Head. Then, move the XY stage by turning the Micrometer Head and align another measuring point with the same cross-hair and take the reading at this point. The difference between the two readings represents the dimension between the two measuring points.

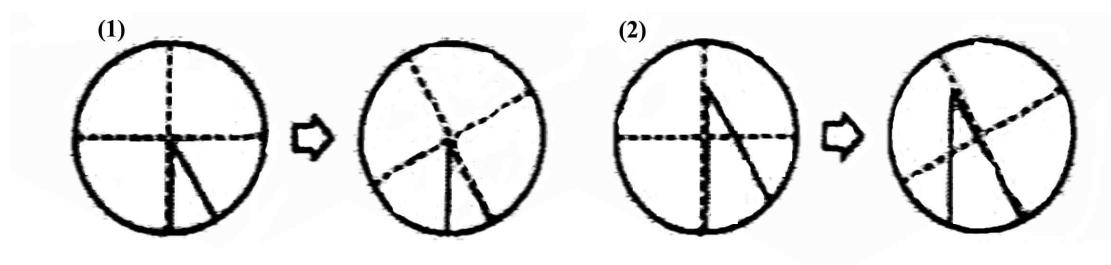
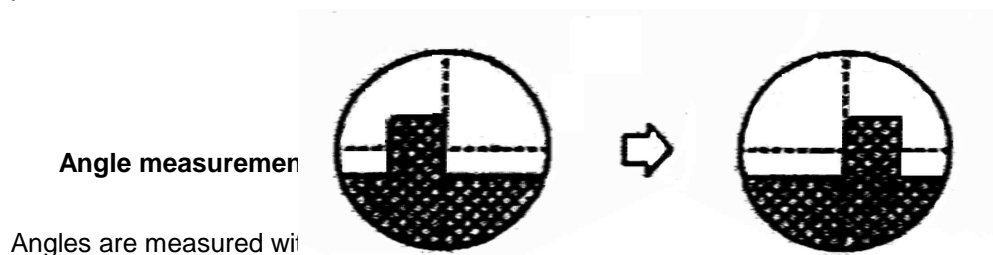

(1) Align an edge of the workpiece with cross-hair reticle and align the end edge with the

center of the cross-hair. Turn the angle dial to align the cross-hair with the other edge of the workpiece. Take readings from the angle dial.

(2) Align two edges of the workpiece with the same cross-hair, one after another, by turning the angle dial and moving the XY stage. Take readings from the angle dial.

1. In both procedures, measuring points on the workpiece are aligned with a cross-hair, one after another. The angle is determined from the difference in reading.
2. The resolution of the angle dial is 1° with the main scale and $6'$ with the vernier scale.
3. The zero position of the angle dial can be adjusted by turning the vernier scale. This allows the angle measurement origin to be set to 0. After turning the vernier scale, check the reticle position. Refer to "2.4.3(1) Adjusting the reticle against the XY stage moving direction" if necessary.

4. Maintenance

This chapter describes the daily and periodical inspection and maintenance required to maintain the performance of this microscope.

Cleaning and Lubrication

(1) Main unit

Periodically apply a thin layer of grease over the slide guide surfaces and rack of the optical tube using a brush.

(2) XY stage

Apply a thin layer of spindle oil to guide rails. After dusting the stage glass wipe it gently with a soft cloth.

(3) Eyepiece and objective

Since the optical glass used for lenses is soft and subject to scratches, always use an air-blower or a feather to dust the lens surface. To remove contaminants such as oil and fingerprints, lightly wipe the surface, using soft gauze or absorbent cotton soaked with high-grade alcohol, in a circular motion.

Inspection

To maintain this microscope in prime condition, periodically inspect the parts specified below.

(1) Connecting parts

Turn off the illuminator select switch knob and pull out the power cord from the AC outlet to

prevent electric shocks.

Check the power cord, AC inlet, voltage selector, GND terminal, reflected illuminator connector, and other joints for looseness and poor connection.

(2) Illuminator select switch and light control knobs

1. Check that the illuminator select switch knob is correctly set.
2. Check that the transmitted and reflected illuminators light by turning the select switch knob to each position.
3. Check that the light intensity of each illuminator changes by turning the light control knob.

(3) Focusing knob

Check this knob for any abnormal tightness, play, unevenness, and sound.

(4) XY stage

1. Check the stage glass for scratches and contaminants.
2. Move the XY stage over the measuring range by hand to check for any abnormal tightness, play, unevenness, and sound. (Perform the same check on the stage by turning the micrometer heads.)

(5) Angle dial

Loosen the angle dial clamp knob and turn the dial to check for any abnormal tightness, play, unevenness, and sound.

(6) Field of view

Look into the eyepiece under transmitted illumination and check the entire field of view for shading and uneven illumination.

(7) XY stage feeding accuracy

This inspection will be affected by the measuring environment, alignment error, and other adverse conditions. Keeping these factors in mind, check the feeding accuracy by measuring a workpiece of a standard scale with an appropriate dimension of 5mm.

1. Position a workpiece, for which accurate dimension is known, on the stage glass and bring it into focus.
2. Align a measuring point on the workpiece with one of the cross-hairs, according to the moving direction of the workpiece.
3. Obtain the dimension from the readings on the Micrometer Head. Refer to "3.2.1 Dimensional measurement".

4. Measure the X-and Y-axis dimensions of the workpiece.

If the difference between the measured and nominal dimensions is less than $5\mu\text{m}$ (for any 5mm travel range), the XY stage feeding accuracy is adequate.

(8) Resolution

Position a workpiece on the XY stage and bring it into focus. Check if any region of the image in the field of view has poor resolution.

Replacing Consumable Parts

(1) Replacing the fuse

1. Turn the illuminator select switch knob to OFF.
2. Pull out the power cord from the main unit.
3. Turn the fuse holder in the direction indicated by the arrow and remove it from the voltage selector. Remove the blown fuse the holder.
4. Insert a new fuse into the holder and replace the holder in the voltage selector.

(2) Replacing the transmitted illumination bulb

The bulb remains hot after it has been turned off. Do not replace the bulb until it has become cool.

1. Turn the illuminator select switch knob to OFF.
2. Remove the stage glass.
3. Turn the green filter counterclockwise to remove it.
4. Remove the bulb by turning it with the supplied bulb setter.
5. Mount a new bulb using the bulb setter.
6. Switch the illuminator select switch knob to transmitted illumination. Check that the bulb lights.
7. Replace the green filter and the stage glass, in this order.

(3) Replacing the reflected illumination bulb

The bulb remains hot after it has been turned off. Do not replace the bulb until it has become cool.

1. Turn the illuminator select switch knob to OFF.
2. Turn the white filter counterclockwise to remove it.
3. Remove the bulb by turning it with the supplied bulb setter. Mount a new bulb using the bulb setter.
4. Switch the illuminator select switch knob to the reflected illumination. Check that the bulb

lights.

5. Replace the white filter.

Packing list

Name	Quantity
1. Industrial microscope.....	1
2. Hex-socket head spanner.....	1
3. Watch screwdriver 2 #	1
4. Gauge block 25mm.....	2
5. Small lamp 24V 0.11A.....	2
6. Fuse 250V 0.5A.....	1
7. Special tool for installation lamp.....	1
8. Working table glass.....	1
9. User's manual.....	1