

Using the 6100A Electrical Power Standard to calibrate energy meters

Application Note

Over the last few years the significance of accurate electrical energy calibration has become increasingly important. With deregulation, increased competition and more cross network power supply transactions, the need to make more measurements, more frequently, and at a higher degree of accuracy, has never been more important. As a consequence, both suppliers and consumers of electrical energy now need to know that what they have distributed or received is exactly what was expected. As a result energy meter calibrations have, in most countries, now become compulsory.

However, energy meter calibration has, until recently, been a task of bringing together a complex array of test instruments, including voltage and current supplies, energy reference meters and pulse comparators. This in itself not only has a detrimental effect on the uncertainty of the whole energy meter calibration process, but is also a costly one to introduce and maintain.

With this in mind Fluke introduced the 6100A Electrical Power Standard, 'Energy' option.

This application note explains how the 6100A can be used to accurately calibrate energy meters without the need for a multitude of test equipment, thereby lowering both testing and maintenance costs while also optimizing the measurement uncertainties and accuracy.



The basic energy meter calibration application

Calibration of instruments that measure energy is no different than any other calibration. The instrument under test is supplied with a known quantity of the parameter being calibrated, and the instrument is interrogated in order to ascertain the value of the parameter that it has measured. This value is then compared with the quantity supplied, and the measurement error is calculated.

Electricity meters, almost without exception, use a technique of generating pulses to indicate the amount of energy they have measured. Each pulse represents a specific number of watt-hours (or VA hours, VAR hours etc). These pulses are transmitted from the meter in a number of different ways.

1. On older meters, energy is recorded by counting the number of passes of a black mark on the surface of a spinning metal disc.
2. By a flashing LED
3. As a direct electrical output (Typically TTL)
4. Some of today's newer meters will even include highly advanced reporting mechanisms such as Ethernet or Bluetooth interfaces.

Because meters are used to measure a wide range of energy, from watt-hours to Gigawatt-hours, the pulses generated can represent different amounts of energy. This amount of energy is specified by the meter manufacturer, and is known as the meter constant (sometimes referred to as 'k').

For example, a specific meter may generate 100 pulses for every kilowatt-hour measured, another may generate the same number of pulses per megawatt-hour measured. Whatever the criteria, the calibration system must have the ability to have this number set within its system in order that it can calculate the correct quantity of energy from the pulse count.

Energy meter calibration methods

Calibrations are typically performed by using a reference measurement technique. A known amount of energy is simultaneously supplied to a reference meter and to the unit under test (UUT). A reading from the reference meter is then compared to a reading from the UUT and the error is calculated. Three separate pieces of calibration equipment are typically required to complete this task.

1. An energy supply (a power supply)
2. A reference energy meter
3. A device for counting pulses from both the reference meter and the UUT, which then compares the two counts and generates an error indication.

The block diagram of the calibration setup is shown in Figure 1.

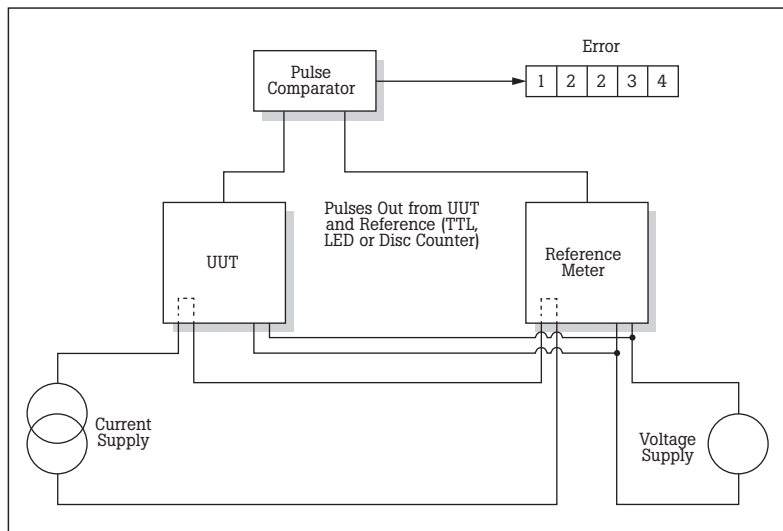

Figure 1. A typical energy meter calibration setup.

In this setup, the 6100A is used simply as the energy supply (current supply and voltage supply), and without the use of any other functions available with the 6100A's energy option.

However, the 6100A energy option does enable the user to perform the calibration without the necessity of using the energy reference meter and/or the pulse comparator, thereby effectively replacing the functionality of both instruments.

Replacing the reference meter with a 6100A

The energy reference meter serves two main purposes. Firstly, it is used to provide a reliable source of traceability, and secondly, to measure the amount of energy actually delivered. The 6100A's ability to measure or calculate time, means that it already knows how much energy it has delivered with a high degree of accuracy. The function of the reference meter, therefore, becomes redundant. In this type of setup, the comparator is still used, but with the 6100A now generating the pulses, instead of the reference meter. To mimic the 'K' value of the meter under test, it is possible to program the 6100A to generate a specific number of pulses, per unit of energy delivered. This calibration setup is shown in Figure 2.

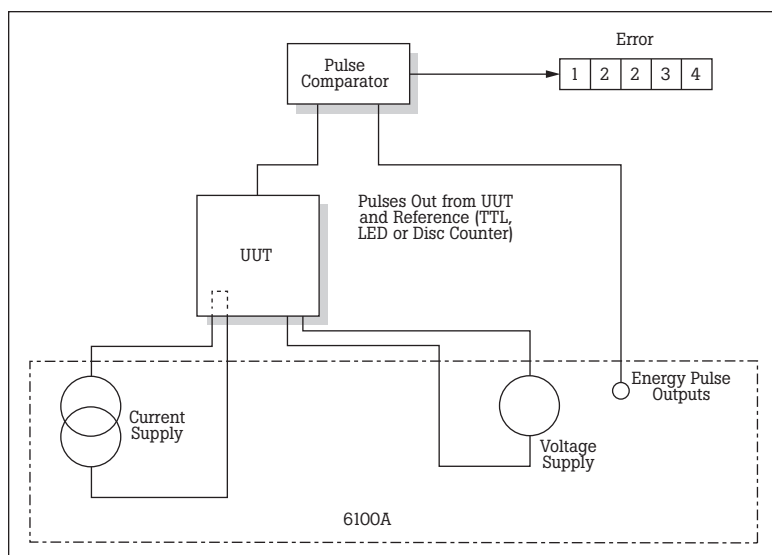

Figure 2. An energy meter calibration setup using a 6100A Electrical Power Standard.

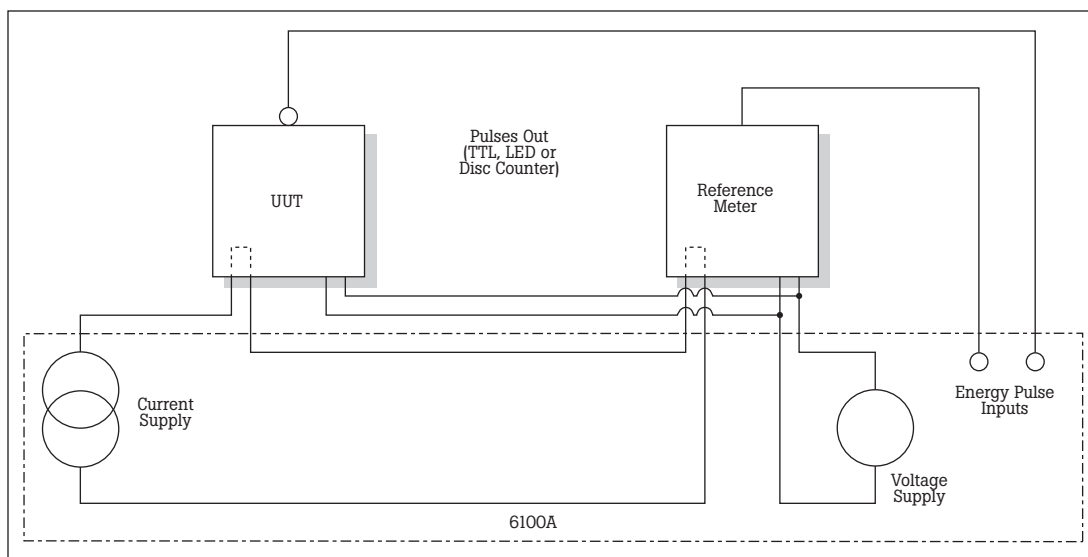

Figure 3. The 6100A Electrical Power Standard eliminates the need for comparators in the calibration setup.

Replacing the comparator with a 6100A

The 6100A's ability to receive, count, and compare pulses means that it can also perform all of the functions of the comparator, effectively making it redundant as well. The setup for this is shown in Figure 3.

Replacing the reference meter and the comparator with a 6100A

Having established that it can effectively replace both the comparator and the reference meter, the 6100A can also combine both of these functions and so replace all of the other instruments required, thereby

allowing it to perform the complete calibration process on its own. This more consolidated setup is shown in Figure 4.

Complex wave shapes—a unique 6100A attribute

In the applications already described, there is a growing requirement to verify or calibrate measurements under non-sinusoidal conditions. In fact, various standards have been in place for a number of years which define testing techniques for energy meters, and, in some cases, actually specify detailed wave shapes that are used for 'type testing' (design qualification against standards).

One such standard is IEC 61036. Standards around the world vary considerably, as does their implementation and legal status. The wave shapes given in Figures 5, 6, 7 and 8 are all examples specifically required by IEC 61036, and were all generated by a 6100A Electrical Power Standard. The half wave rectified signal, phase fired signal and burst fire signal can all be generated on either the voltage or current channels, but under normal circumstances would usually be performed using the latter. These wave shapes are easily replicated on the 6100A's voltage or current channels.

The 6100A's four testing modes

When used to test, calibrate or verify energy meters, the 6100A can be used in any one of four testing modes. These are:

- Free running mode
- Counted/Timed mode
- Gated mode
- Energy packet mode (also known as Dose mode)

Each offer benefits specific to the type of test being performed.

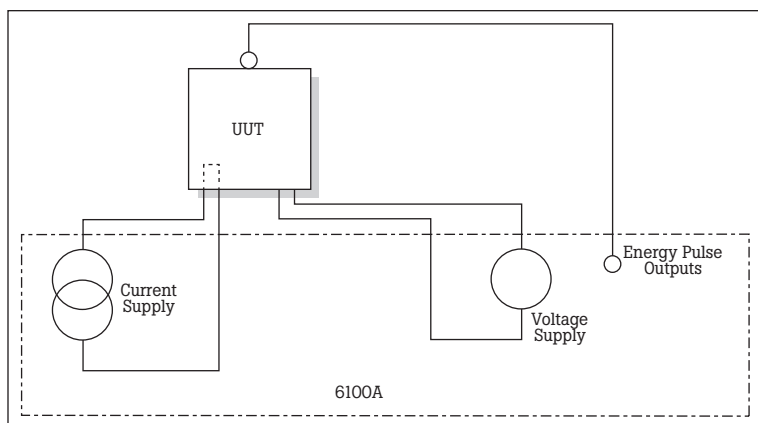

Figure 4. Using a 6100A Electrical Power Standard to eliminate the comparator and reference meter, as well as a supply for both voltage and current.

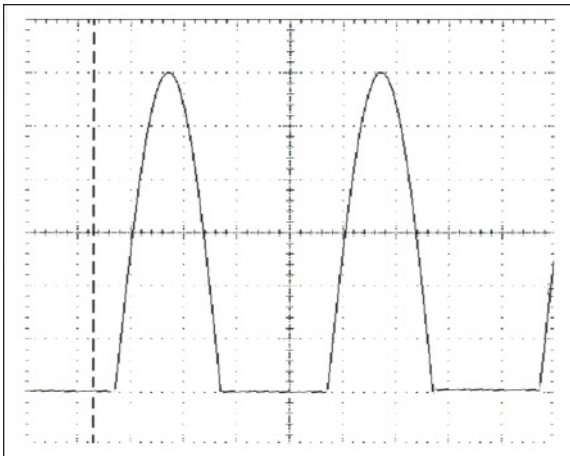

Figure 5. Half-wave rectified signal.

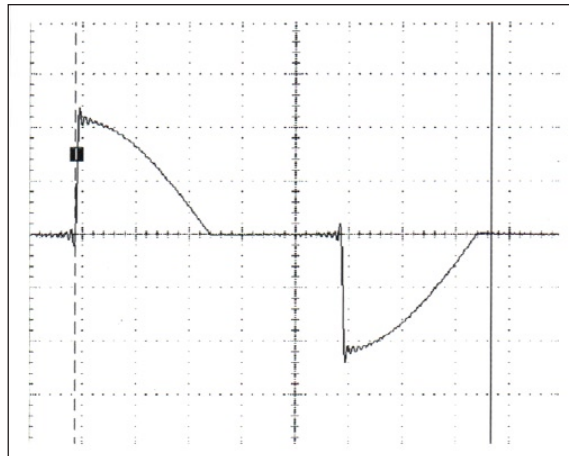

Figure 6. Phase fired signal.

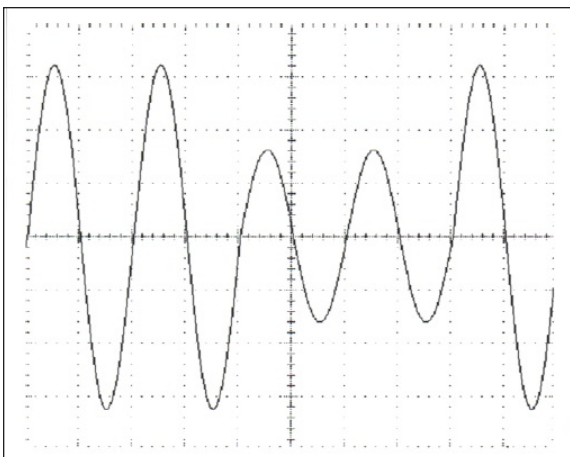

Figure 7. Burst fire signal.

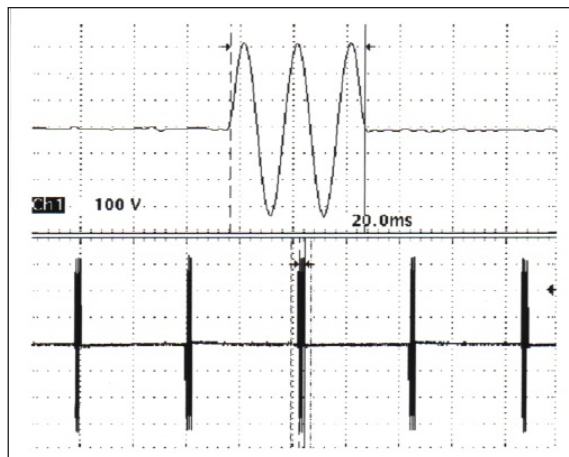

Figure 8. Voltage dips and short interruptions.

Free running mode

In free running mode, the 6100A will not begin counting meter pulses until the output (OPER)ate switch is turned on. Once the output switch is enabled, counting will continue indefinitely until the switch is once again turned off. In this mode no time

constants or energy criteria are specified. This is particularly useful for meter verification testing, as it quickly establishes the condition of the energy meter.

Free running mode is also useful for carrying out creep tests or even simply to make adjustments to a meter. Creep testing is when the voltage coils

of the energy meter are energized with the rated voltage, but with no current in any current coil. The test is performed over a specific period of time and, fundamentally, establishes how much the meter dial advances without any usage by the consumer.

This is easily done using the 6100A's basic setup user interface screens described in this application note.

Counted/Timed mode

When the 6100A is set up in Counted/Timed mode the user must first enter or select data within three panels on the 'energy counter/time mode' screen before counting is initiated (see Figure 9).

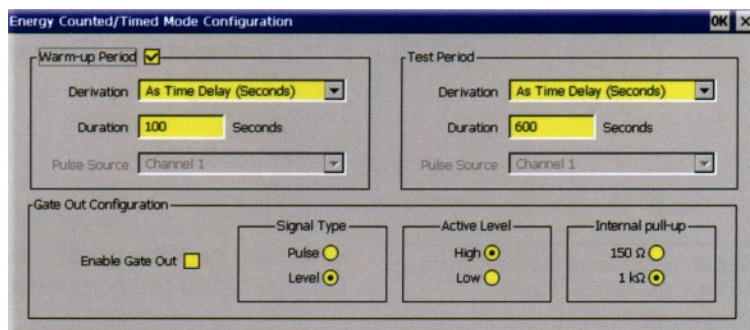

Figure 9. Energy Counter/Timer mode configuration screen.

First – a warm-up time can be specified. This allows the user to run the meter for a user-definable period of time, so that the energy meter can reach a suitable operating temperature, prior to testing.

Then, the test period criteria must be selected. This panel incorporates three selection criteria:

1. Derivation
2. Duration
3. Pulse source

The selection made within the 'Derivation' drop down menu determines the way the 6100A delivers the energy required. This can be specified in either time, pulse counts, or as a measure of energy.

The 'duration' entry is merely a length or period of time, dependent upon the selection made within the 'Derivation' drop down menu. This will be specified as either a time in seconds, minutes or hours, a number of counts, or Watt hours (stated in either Watt hours, kilo Watt hours or Mega Watt hours).

Having chosen the method in which energy is delivered, a pulse source must then be

chosen. This will identify which channel, or channels, on the 6100A are used to input the counting pulses from the energy meter. It is worth noting at this point that with six channels, the 6100A is also capable of testing multi-phase energy meters with multiple pulse outputs, as well as those with a single pulse output.

Finally, an 'Energy Gate In/Out' socket on the rear of the 6100A can be enabled and then configured according to the user's requirements. Having enabled the 'Energy Gate Out' function, the operator can select the signal types as either a signal consisting of a level to the required duration or as a start and end pulse. This can also be either active high or low. Lastly, the source impedance of the internal pullup resistor can be specified as either 150 Ω or 1 kΩ, to match the meter or monitoring system's own source impedance. This should be determined from the equipment's own user manual prior to connecting to the 6100A.

Gated mode

In Gated mode the user has the opportunity to remotely activate the 6100A's output and counting cycle. This is achieved by applying an 'active' signal to the 6100A's 'Energy Gate In/Out Connector' on the rear panel. This connector automatically becomes an input socket when the gated mode is selected. However, before testing can begin, the parameters of the 'active' signal being used must first be configured within the 6100A's 'Energy Gated Mode Configuration' screen (see Figure 10). Here, the signal type, active signal level and internal pull-up parameters must initially be set up. Details on how to do this can be found in the 6100A user manual.

Having completed this process, the 6100A now requires the user to enter the length of the test period, in readiness to switch either the output or counting function on and off from an alternative piece of test equipment or system with 'active' signal capability. This could be a PC set up with the user's own dedicated software program, designed specifically to give arbitrary time, energy or count control of the 6100A.

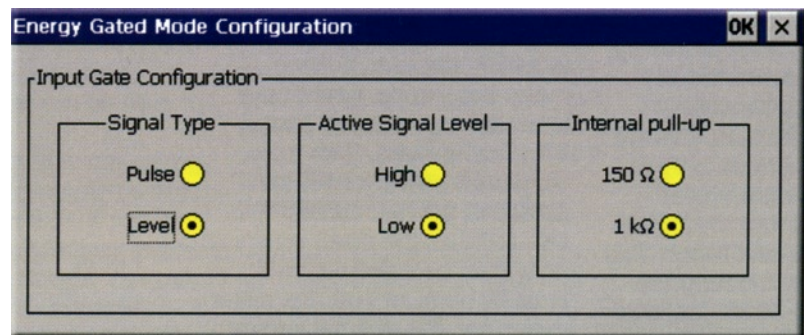

Figure 10. Energy Gated mode configuration screen.

Energy packet mode

In energy packet mode, also known as dose mode, the power from the output terminals is timed to deliver the requested amount of energy to the meter under test. This can be defined as either energy, counts or time.

However, unlike Counted/ Timed mode, there is no warmup period. This is advantageous to those wishing to eliminate initial dial advance on the meter under test. Dial advance is when both the reference meter and meter under test advances more than the measured amount on the 6100A. This is perfectly normal and represents settling and warm-up times included in the test. Furthermore, please note that when using the 6100A's other modes, the actual test duration and count to achieve the displayed result is perfectly accurate. In energy packet mode dial advance does not become an issue as there is no warm-up period.

As with other modes, the mode's own configuration screen must be set up prior to testing. See Figure 11.

The 6100A's user interface and basic setup

The 6100A's energy user interface can be accessed via the waveform menu. Note: If accessed directly from power-up, then the 'Esc' key on the keyboard must be pressed first. Here, a softkey labeled 'Energy Counting' can be found. Upon selecting this key, the user must then configure the 6100A according to his test setup. This can be done by selecting the softkey 'Configure Meter Constants', which in turn accesses the 'Channel Configuration and Meter Constants' screen (see Figure 12).

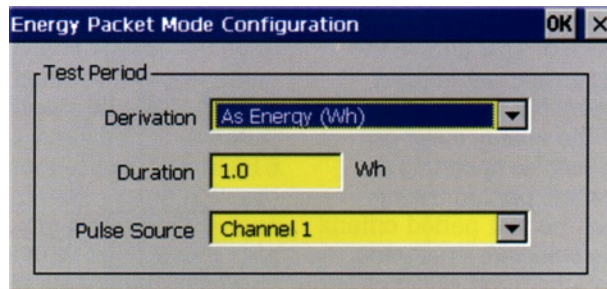

Figure 11. Energy packet mode configuration screen.

The first panel, 'MUT Source', determines which sockets on the front panel of the 6100A are being used as energy pulse inputs. A number of different configurations can be set up in this panel, from one to six single phase meters, or even a single pulse three phase meter (The 'Sum of Channel 1,2 and 3' check box).

Having identified the pulse source channel(s), the user must then select the reference source. This will depend upon which circuit (as shown in Figures 2, 3 and 4) the user has chosen to perform the tests. If the 6100A's internal reference is being used, as shown in Figure 4, the check box 'Main Output' must be selected. Alternatively, if either an external single phase or three phase meter is utilized as a reference, then one of five other check boxes must be selected, according to the test setup being used. Two such examples are shown in Figures 1 and 3.

The 'Meter Constant Base' drop-down menu allows users to select any one of three meter base units, depending upon the meter being tested—Wh (Real power), VAh (Apparent power or VARh (Reactive power). Having selected this, the

meter constants must then be specified. This must be done for both the meter under test, the external energy reference meter (if used) and finally, the reference pulse output of the 6100A. For both the 'Meter Constant (MUT)' and 'Meter Constant (Reference)' panels, this will be entered according to the output specifications of the meter under test and external energy reference meter (if used). In the case of the 'Meter Constant (Output)' panel, a value can be set which specifies the effective meter constant of the 'Pulse Out' connector. Whenever an energy test is active, this output is a pulse stream representing the total power and energy of the active V/I outputs of all 6100A/ 6101A's in the system.

There are also internal user selectable pull-up resistors for pulse inputs. This is particularly useful for meters with open collector outputs. A separate pullup resistor is associated with each meter constant. For the meter under test and reference meter, these can be selected as either 150 Ω or 1 kΩ. Similarly, a user selectable internal pull-up is provided for the main output's energy pulse output. This can be selected or deselected using the 'Use Internal pull-up' check box.

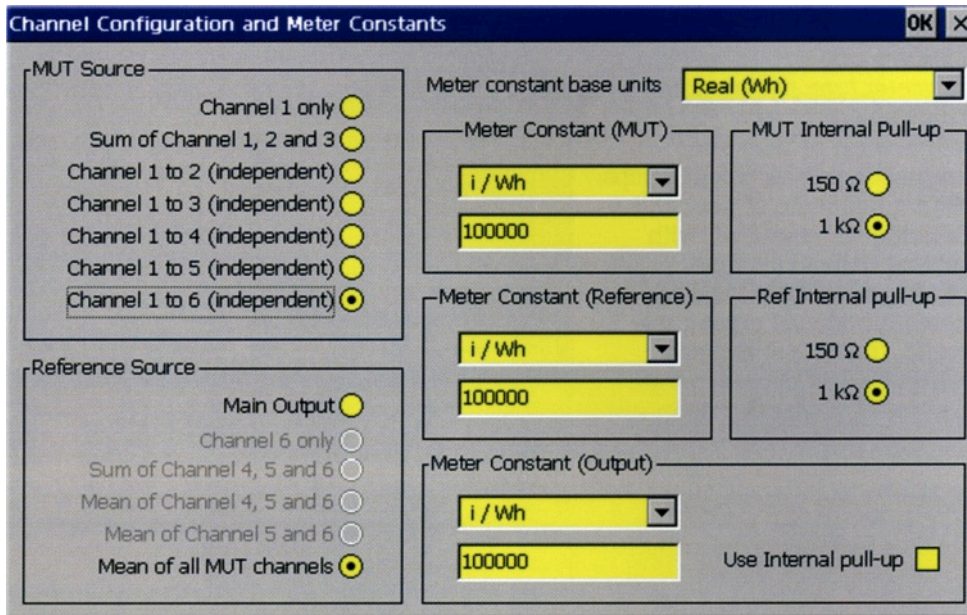

Figure 12. Channel Configuration and Meter Constants screen.

The basic setup is now complete. The user can now enter the required combinations for L1 (L2 and L3 if using a two, three or four phase system) via the 6100A's output menu. Now the meter testing is ready to begin. To start the test the user simply presses the 6100A's green 'OPER' button—unless in 'Gated mode', whereupon the 6100A's 'OPER' button must first be pressed, before the 6100A can identify the appropriate gate signal to begin the test. A typical output menu screen when running a full test can be seen in Figure 13.

At this point it is worth noting that the 6100A can only be used with devices that have a provision for independent (auxiliary) power for their internal circuits. The task of the 6100A is to accurately maintain its voltage output at the shape and level demanded by the user for a wide range of loads. The 6100A cannot maintain its precision output if loaded by the short-term cycle-by-cycle variations in current demanded by the meter under test's power supply units.

Typical 6100A energy applications

Energy meter testing typically falls into one of three categories:

- In service testing/calibration
- Manufacturing testing
- Type testing/approval

In service testing/calibration

In service testing/calibration is where energy meters already in the field are brought in at regular intervals for verification and/or calibration. This regime varies from country to country, however in most cases energy meters will be batch tested in a meter shop, several meters at a time. This is particularly prominent in some countries where state law dictates that consumer energy meters must be tested each year. With this in mind, these countries have meter testing shops in abundance. Clearly, to get through such numbers in one year requires batch testing on a large scale. To overcome this, several energy meters are wired into vast meter testing arrays with multiple sensors. Smaller arrays can test ten meters simultaneously.

In some countries, this number can rise to one hundred and beyond. There may be many advantages to testing meters in this way—not least the high numbers that can be tested at one time. However, there are several disadvantages too. The greatest one is the amount of power required to carry out such tests. Plainly, this type of application, on power alone, is outside the 6100A's, or any of its configured systems, intended workload. However, that said, it is also becoming common for such meter shops to employ a 'specials' test rig. This type of versatile test rig is designed to accommodate other such energy meters that for one reason or another cannot be tested in the larger arrays. This may be due to physical size, unique environment requirements or even for non compatibility reasons. For such lower denomination test rigs the 6100A is ideal. Power requirements are a lot lower and the number of input channels required to perform the tests is easily within even a single 6100A's capability.

Manufacturing testing and type testing/approval

Meter manufacturers are using 6100A's and 6100A systems for meter type testing and approval work, within their own design centers and engineering development groups. With a multitude of new and differing standards, all with several derivations from country to country, regularly being introduced around the world, the 6100A is being recognized as the only single box solution that can replicate and test them all. Furthermore, it can do so with the highest accuracy and traceability.

For the energy meter manufacturers this whole new philosophy of type testing and approval was driven primarily by their customers—utility companies (and other similar operators) and the regulatory agencies associated with them. Now, all of these organizations use the 6100A to test their energy meters prior to deployment, to verify them before use into a new installation. However, these very same companies and organizations are now also using the 6100A to verify existing meters in the field, particularly in circumstances of dispute.

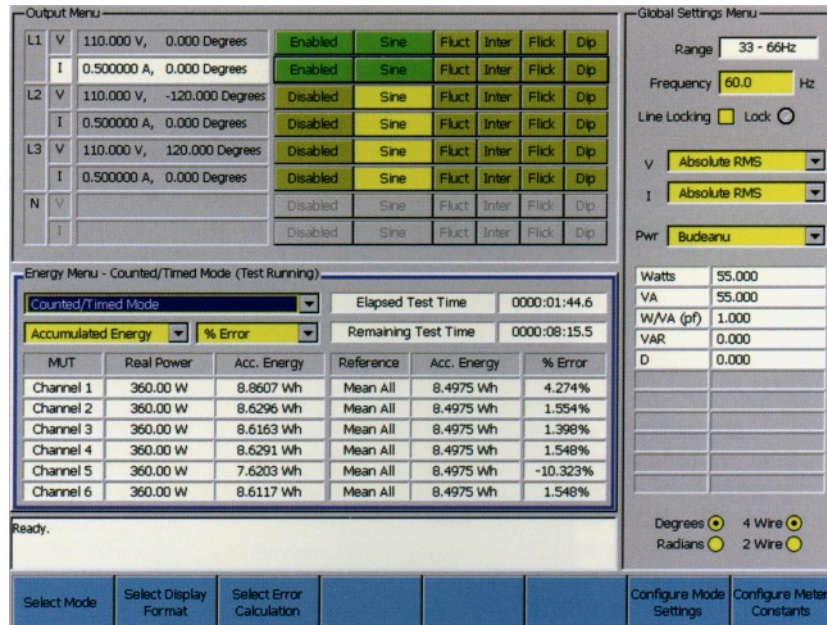

Figure 13. The 6100's Output Status screen.

With several different 'type testing' applications around the world, most users see it as a means to verify, calibrate or design their energy meters for type approval. In many countries, conforming to the necessary standards has become a legal requirement.

In Europe, meter manufacturers, utility companies and external regulatory agencies all adhere to the requirements of IEC 61036. In other parts of the world, similar standards exist and consequently dictate the way energy meters are both manufactured and applied.

Fluke 6100A Electrical Power Standard



The most accurate, comprehensive and flexible source of electrical power signals

Fluke. Keeping your world up and running.®

Fluke Corporation
PO Box 9090, Everett, WA 98206 U.S.A.

Fluke Europe B.V.
PO Box 1186, 5602 BD Eindhoven, The Netherlands

For more information call:
In the U.S.A. (800) 443-5853 or Fax (425) 446-5116
In Europe/M-East/Africa +31 (0) 40 2675 200 or Fax +31 (0) 40 2675 222
In Canada (800)-36-FLUKE or Fax (905) 890-6866
From other countries +1 (425) 446-5500 or Fax +1 (425) 446-5116
Web access: <http://www.fluke.com>

©2009 Fluke Corporation. Specifications subject to change without notice. Printed in U.S.A. 1/2009 2130388 A-EN-N Rev B Pub_ID: 10781-eng, Rev 02

Modification of this document is not permitted without written permission from Fluke Corporation.