

| | |
|------------|------------|
| Serial No. | H-A045-E-9 |
|------------|------------|

Butterfly Valve

Electric Actuated Type T

Type 57: 40mm(1 1/2")~350mm(14")

User's Manual

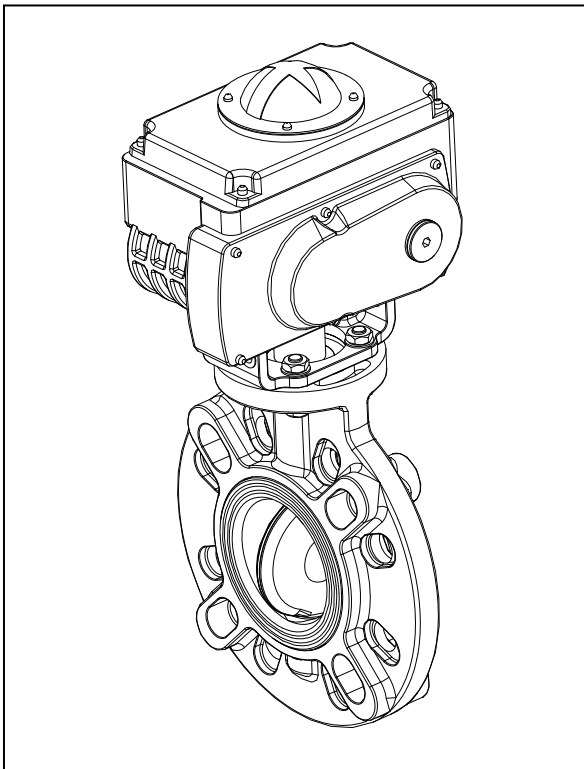



Contents

- (1) Be sure to read the following warranty clauses of our product 1
- (2) General operating instructions 2
- (3) General instructions for transportation, unpacking and storage 3
- (4) Name of parts 4
- (5) Working pressure vs. temperature 5
- (6) Specification of actuator 6
wiring diagram 7
- (7) Installation procedure 8
- (8) Support setting procedure 11
- (9) Electric wiring procedure 12
- (10) Operating procedure 13
Manual operating procedure 14
Motor-driven operating procedure 14
- (11) Disassembling method for replacing parts 15
- (12) Adjustment limit switch 17
- (13) Inspection items 18
- (14) Troubleshooting 19
- (15) Handling of residual and waste materials 20





This user's guide contains information important to the proper installation, maintenance and safe use of an ASahi AV Product. Please store this manual in an easily accessible location.

<Warning & Caution Signs>

| | |
|--|---|
|  Warning | This symbol reminds the user to take caution due to the potential for serious injury or death. |
|  Caution | This symbol reminds the user to take caution due to the potential for damage to the valve if used in such a manner. |

<Prohibited & Mandatory Action Signs>

| | |
|---|--|
|  | Prohibited: When operating the valve, this symbol indicates an action that should not be taken. |
|  | Mandatory action: When operating the valve, this symbol indicates mandatory actions that must be adhered to. |

(1) Be sure to read the following warranty clauses of our product

- Always observe the specifications of and the precautions and instructions on using our product.
- We always strive to improve product quality and reliability, but cannot guarantee perfection. Therefore, should you intend to use this product with any equipment or machinery that may pose the risk of serious or even fatal injury, or property damage, ensure an appropriate safety design or take other measures with sufficient consideration given to possible problems. We shall assume no responsibility for any inconvenience stemming from any action on your part without our written consent in the form of specifications or other documented approval.
- The related technical documents, operation manuals, and other documentation prescribe precautions on selecting, constructing, installing, operating, maintaining, and servicing our products. For details, consult with our nearest distributor or agent.
- Our product warranty extends for one and a half years after the product is shipped from our factory or one year after the product is installed, whichever comes first. Any product abnormality that occurs during the warranty period or which is reported to us will be investigated immediately to identify its cause. Should our product be deemed defective, we shall assume the responsibility to repair or replace it free of charge.
- Any repair or replacement needed after the warranty period ends shall be charged to the customer.
- The warranty does not cover the following cases:
 - (1) Using our product under any condition not covered by our defined scope of warranty.
 - (2) Failure to observe our defined precautions or instructions regarding the construction, installation, handling, maintenance, or servicing of our product.
 - (3) Any inconvenience caused by any product other than ours.
 - (4) Remodeling or otherwise modifying our product by anyone other than us.
 - (5) Using any part of our product for anything other than the intended use of the product.
 - (6) Any abnormality that occurs due to a natural disaster, accident, or other incident not stemming from something inside our product.

(2) General operating instructions



Warning



- Do not disassemble or remodel the actuator.

- Keep hands and other extremities away from moving parts under all circumstances.

(Any such practice may get your hand, arm, or other part of your body caught.)

- Using a positive-pressure gas with our plastic piping may pose a dangerous condition due to the repellent force particular to compressible fluids even when the gas is under similar pressures used for liquids. Therefore, be sure to take the necessary safety precautions such as covering the piping with protective material. For inquiries, please contact us. For conducting a leak test on newly installed piping, be sure to check for leaks under water pressure. If absolutely necessary to use a gas in testing, please consult your nearest service station beforehand.

- Before using the product, check the operating power supply and the voltage specification on the nameplate. Using an improper voltage may cause equipment damage or malfunction.

- Before manual operation, ensure that the actuator is not activated by the motor.



Caution

- Do not step on or apply excessive weight on valve. (It can be damaged.)

- Do not use AV valves in a place where they may become submerged in water.

- Do not apply a great impact or vibration to the actuator.

(Any such practice may result in breakdown.)

- While in operation, the actuator may rise in surface temperature. This is due to heat-up of the inner equipment and is not a sign of a breakdown. However, exceeding the permissible temperature may cause a breakdown.

- Do not use the valve in conditions where the fluid may have crystallized.

(The valve will not operate properly.)



- Keep the valve away from excessive heat or fire. (It can be damaged, or destroyed.)

- Avoid locations with corrosive gas or otherwise bad atmospheres. Install a cover or something similar that covers the entire area.

- Always operate the valve within the pressure vs. temperature range.

(The valve can be damaged or deformed by operating beyond the allowable range.)

- Allow sufficient space for maintenance and inspection.

- Select a valve material that is compatible with the media. For chemical resistance information, refer to "CHEMICAL RESISTANCE ON ASAHI AV VALVE".



(Some chemicals may damage incompatible valve materials.)

- Keep the valve out of direct sunlight, water and dust. Use cover to shield the valve.

(The valve will not operate properly.)



- Perform periodic maintenance. (Leakage may develop due to temperature changes or periods of prolonged storage, rest, or operation.)

- When installing a valve, provide an appropriate support. (Lack of such a support may cause the valve and piping to be overstrained, resulting in damage or other defect.)



  - In the case of malodor, overheating, or smoking, turn off the power supply immediately. (Continued use despite an abnormality present may result in a fire. If you detect any abnormalities, be sure to consult the dealership where you bought the product or our service station nearest your premises and ask them to perform an inspection.)

- For manual operation, be sure to use the handle furnished with the product by the manufacturer.
- When using the product in explosive atmosphere, ensure that the actuator complies with the explosion-proof specifications required for that area.
- Keep the ambient temperature of the installed location within the range -10°C and 60°C.

(3) General instructions for transportation, unpacking and storage

  - When suspending and supporting a valve, take care and do not stand under a suspended valve.

Warning

  - This valve is not designed to handle impacts of any kind. Avoid throwing or dropping the valve.

Caution

- Avoid scratching the valve with any sharp object.
- Do not over-stack cardboard shipping boxes. Excessively stacked packages may collapse.
- Avoid contact with any coal tar creosote, insecticides, vermicides or paint. (The force of swelling may damage the valve.)
- When transporting a valve, do not carry it by the handle.
-  - Store products in their corrugated cardboard boxes. Avoid exposing products to direct sunlight, and store them indoors (at room temperature). Also avoid storing products in areas with excessive temperatures. (Corrugated cardboard packages become weaker as they become wet with water or other liquid. Take care in storage and handling.)
- After unpacking the products, check that they are defect-free and meet the specifications.

(4) Name of parts

40mm(1-1/2")-350mm(14")

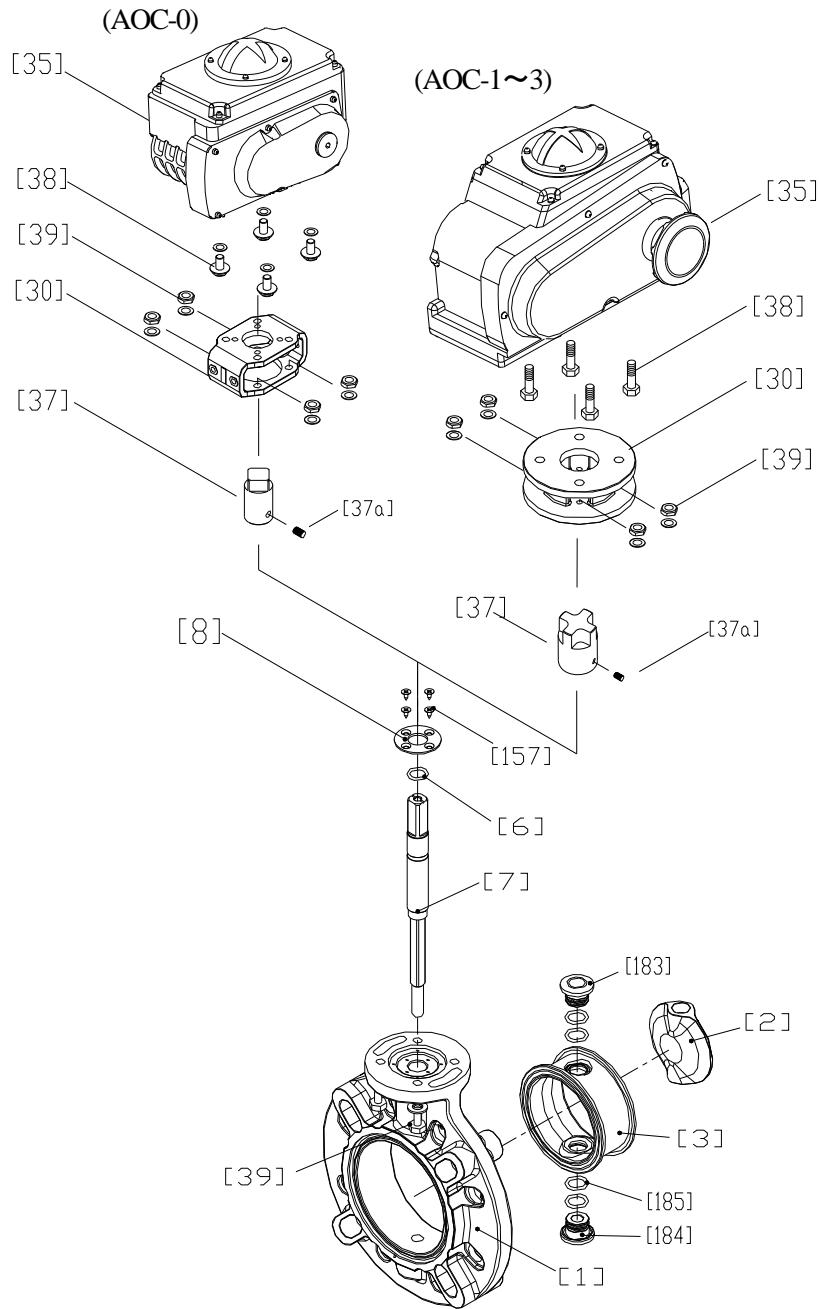

| No. | Description | No. | Description | No. | Description |
|-----|-----------------|-------|---------------|-------|---------------|
| [1] | Body | [30] | Stand | [157] | Screw (F) |
| [2] | Disk | [35] | Actuator | [183] | Seat Bush (A) |
| [3] | Seat | [37] | Joint (A) | [184] | Seat Bush (B) |
| [6] | O-Ring (C) | [37a] | Screw (C) | [185] | O-Ring (I) |
| [7] | Stem | [38] | Bolt (E) | | |
| [8] | Stem Holder (A) | [39] | Bolt, Nut (A) | | |

(5) Working pressure vs. temperature

BUTTERFLY VALVE TYPE57

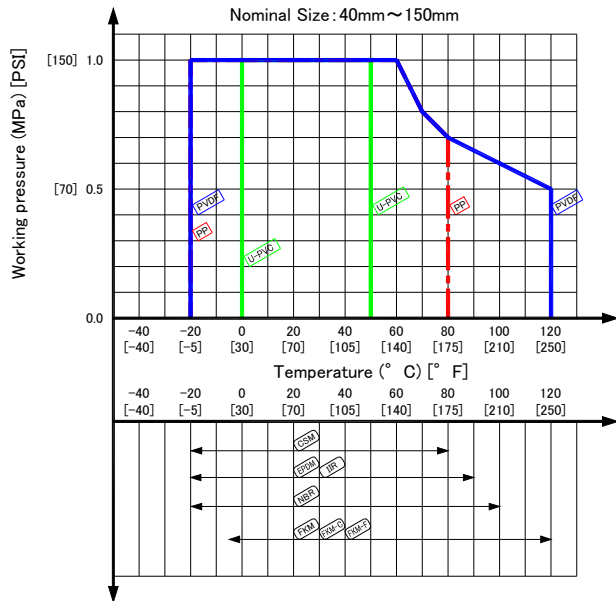

BUTTERFLY VALVE TYPE57

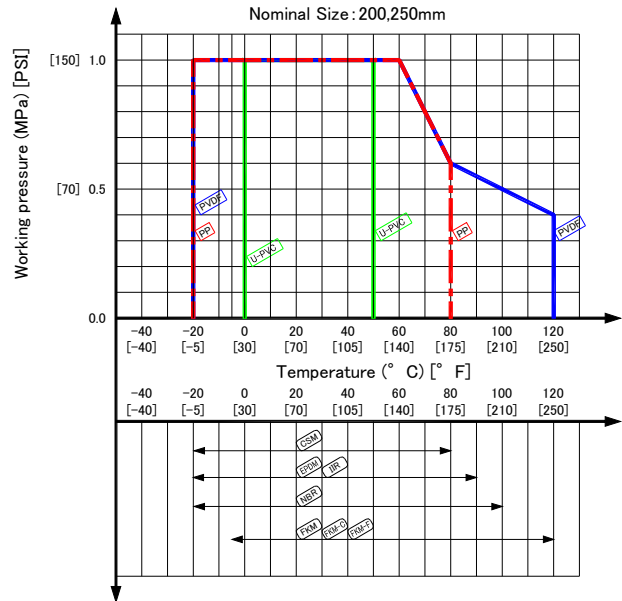

BUTTERFLY VALVE TYPE57

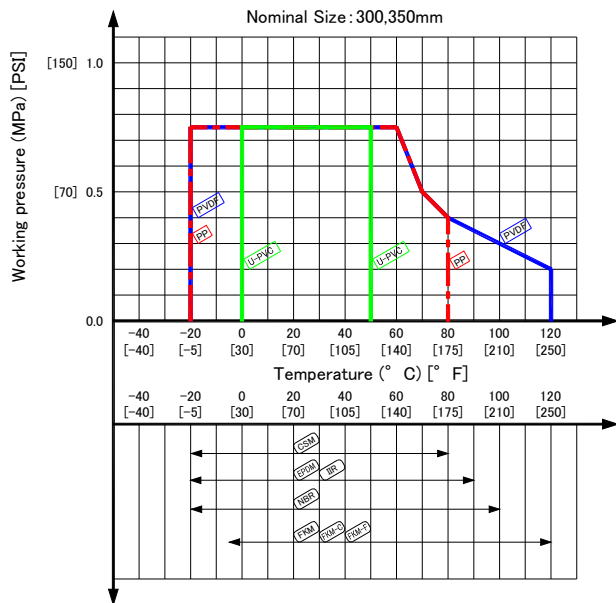

(6) Specifications of actuator

List of Specifications

| Nominal Size | | | 40~100mm (2"-4") | 125mm (5") | 150mm (6") | 200mm (8") | 250~350mm (10"-14") | |
|--|--------------|-------|---|---------------|---------------|---------------|------------------------|-----------|
| Actuator Type | | | AOC-0 | AOC-1 | AOC-2 | AOC-2.5 | AOC-3 | |
| Opening and Closing Time (Sec.) | | 50Hz | 25 | | | 37 | 55 | |
| | | 60Hz | 20 | | | 30 | 50 | |
| Protection Structure | | | Protection Grade 5 JIS C 0920 (corresponded IP65) | | | | | |
| Motor Starting Current (A) 50/60Hz | AC100V | *100V | 1.2/1.2 | 1.6/1.4 | 2.4/2.4 | | 5.1/4.8 | |
| | AC110V | | 1.4/1.4 | 1.7/1.7 | 2.5/2.5 | | 6.1/6.6 | |
| | AC200V | *200V | 0.5/0.5 | 0.7/0.7 | 1.1/1.1 | | 2.6/2.4 | |
| | AC220V ※1 | | 0.7/0.7 | 0.8/0.9 | 1.2/1.2 | | 3.1/3.0 | |
| | AC220V ※2 | *220V | / | | 0.7/0.7 | 1.1/1.0 | | 2.3/2.3 |
| | AC240V | *240V | 0.5/0.5 | 0.6/0.6 | 0.9/0.9 | | 2.1/2.2 | |
| Motor Rated Current (A) 50/60Hz | AC100V | *100V | 0.50/0.50 | 0.70/0.60 | 0.90/1.20 | | 1.60/1.70 | |
| | AC110V | | 0.60/0.60 | 0.90/0.70 | 1.00/1.20 | | 1.70/1.80 | |
| | AC200V | *200V | 0.25/0.25 | 0.40/0.30 | 0.50/0.80 | | 0.80/1.00 | |
| | AC220V ※1 | | 0.30/0.30 | 0.50/0.40 | 0.60/0.80 | | 0.90/1.00 | |
| | AC220V ※2 | *220V | / | | 0.40/0.30 | 0.50/0.50 | | 0.70/0.80 |
| | AC240V | *240V | 0.25/0.25 | 0.30/0.30 | 0.50/0.60 | | 0.60/0.60 | |
| Number of Rotation of Manual Operating Handle | | | 6.7 | 16.5 | | | | |
| Nominal Diameter of Cable Connector | | | G1/2 (PF1/2) | | | | | |
| Motor Rated Output (W) | | | 8 | 20 | 30 | | 90 | |
| Type of Motor Insulation | | | E kind | | | | | |
| Motor Rated Time (min.) | | | 30 | | | | | |
| Capacity of Limit Switch | | | AC250V 10A | | | | | |
| Space Heater Rated Output (W) | | | 8 | | | | | |

* Voltage of Motor

※1 : Standard, Potentiometer, Intermediate Limit Switch(no-volt)

※2 : Speedcontrol Unit, E-E Positioner

Wiring Diagram

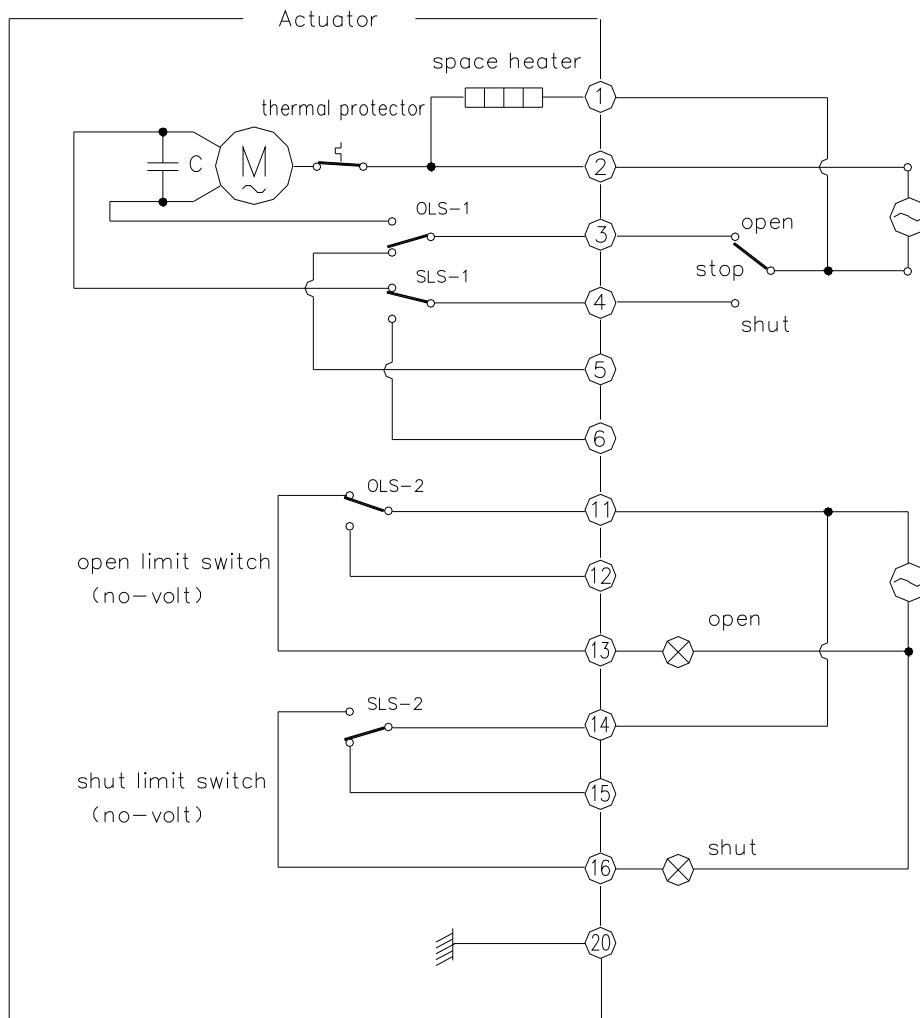

Note: The circuit diagram shows the position that the opening rotation has come to the end of travel.

Switching Chart

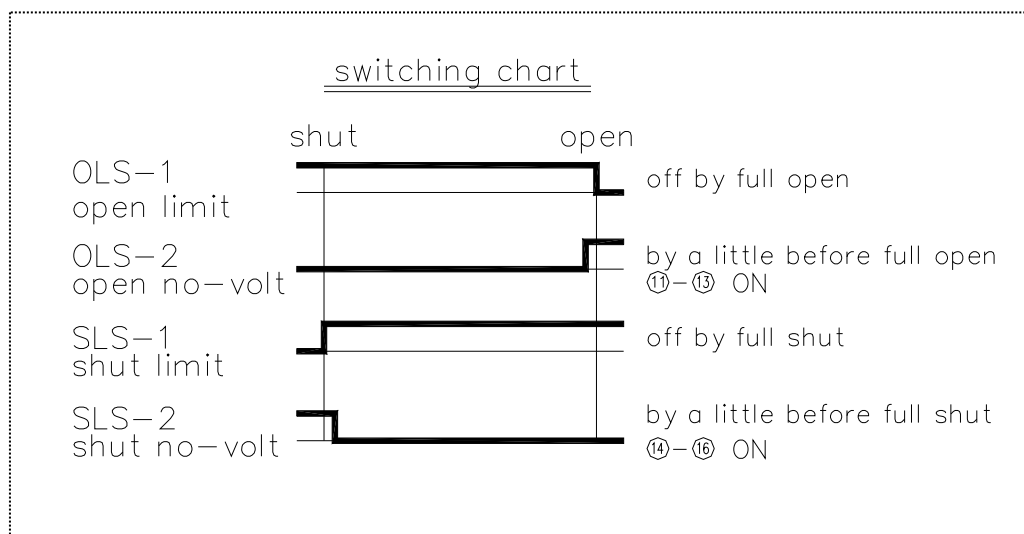

(7) Installation procedure



Warning



- When suspending and supporting a valve, take care and do not stand under a suspended valve.

- Be sure to conduct a safety check on all hand and power tools to be used before beginning work.
- Wear protective gloves and safety goggles as fluid remain in the valve even if the pipeline is empty. (You may be injured.)



Caution

- When installing a pipe support by means of a U-band or something similar, take care not to over-tighten. (Excessive force may damage the pipe.)

- When installing the piping, do not do so with the valves fully closed. (The disc may pinch into the seat, resulting in a high operating torque, thus disabling opening and closing.)

- The installed valve must never be opened or closed when foreign matter such as sand is present in the pipeline.



- When installing pipes and valves, ensure that they are not subjected to tension, compression, bending, impact, or other excessive stress.

- Use flat faced flanges for connection to AV Valves.

- Ensure that the mating flanges are of the same standards.

- The gasket is unnecessary.

(The seat carries out the role of the gasket.)

- The valve disc is in the position indicated by solid lines in figure to the right prior to shipment from the factory. If the valve is opened or closed after unpacking, it must be reset in this position before installation. Failure to do so will result in damage to the surface of the valve seat during handling and installation.

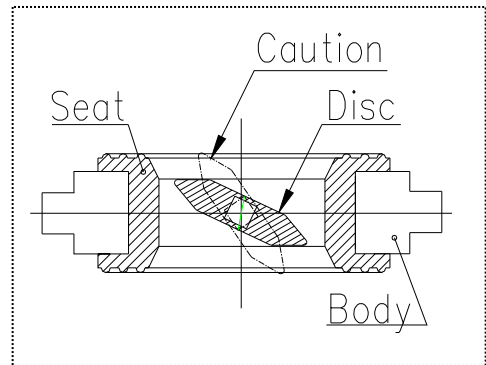

- Care must be used during piping installation to ensure that the pipes or flanges are properly aligned so that the valve disc does not contact them in any setting. Misalignment as in figure below will result in damage to the valve.

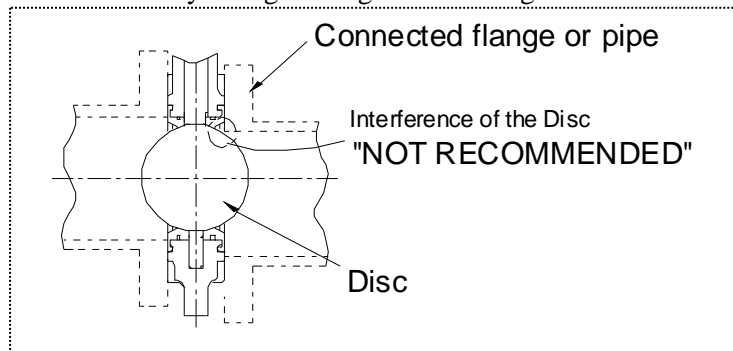

In case the wall-thickness of the connection part (Flange and Pipe) is too thick, shave the flange or the pipe inside in order to avoid the contact of pipe and disc. If inside diameter of the connection part is larger than size D, shaving is not necessary.

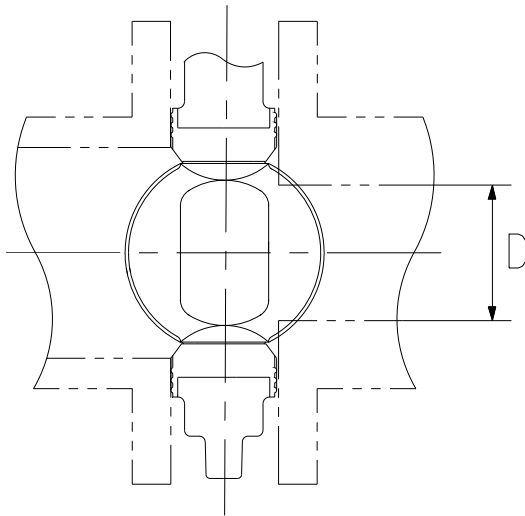

| Nominal Size | Diameter D |
|---------------|----------------|
| 40mm (1 1/2") | 31mm (1.22") |
| 50mm (2") | 43mm (1.69") |
| 65mm (2 1/2") | 57mm (2.25") |
| 80mm (3") | 67mm (2.64") |
| 100mm (4") | 91mm (3.59") |
| 125mm (5") | 113mm (4.45") |
| 150mm (6") | 137mm (5.40") |
| 200mm (8") | 179mm (7.05") |
| 250mm (10") | 231mm (9.10") |
| 300mm (12") | 280mm (11.03") |
| 350mm (14") | 333mm (13.12") |

Necessary items

- Torque Wrench
- Spanner Wrench
- Bolt, Nut, Washer (For many flanges specification)

Procedure

- 1) Install the valve between flanges and open the valve slightly.
- 2) Insert bolts, set nuts and washer and tighten the bolts and nuts temporarily by hand.

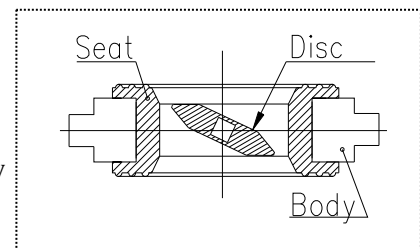

- When you insert a valve between flanges, please insert after extending the fields of flanges fully. (If you insert a valve by force without fully extending fields of flanges, a liner may be turned over and suffer a crack..)

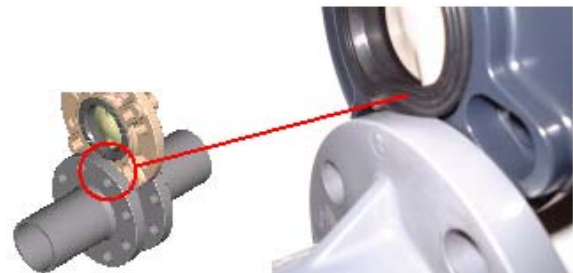

Valve Face to Face Dimensions

Unit : mm (inch)

| Nom. Size | 40mm (1 1/2") | 50mm (2") | 65mm (2-1/2") | 80mm (3") | 100mm (4") | 125mm (5") | 150mm (6") | 200mm (8") | 250mm (10") | 300mm (12") | 350mm (14") |
|--------------|---------------|-----------|---------------|-----------|------------|------------|------------|------------|-------------|-------------|-------------|
| Face to Face | 39 (1.5) | 42 (1.7) | 46 (1.8) | 46 (1.8) | 56 (2.2) | 66 (2.6) | 71 (2.8) | 87 (3.4) | 110 (4.3) | 129 (5.1) | 129 (5.1) |

*Don't make the disc protrude from the seat.
(If not, the disc may be damaged.)

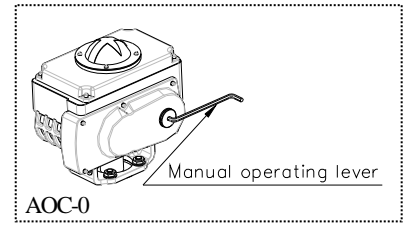

- 4) Tighten the bolts and nuts gradually with torque wrench to the specified torque in a diagonal manner (Refer to fig.1.)
- *Avoid excessive tightening. (The valve can be damaged.)

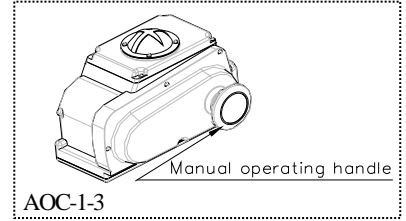

Caution - Tighten the bolts and nuts gradually with a torque wrench to the specified torque level in a diagonal manner.

| Recommended Torque Value | | Unit: N·m {kgf·cm} [lb·inch] | | |
|--------------------------|------------------------|------------------------------|------------------------|------------------------|
| Nom. Size | 40mm (1 1/2") | 50, 65mm (2", 2 1/2") | 80, 100mm (3", 4") | 125, 150mm (6", 8") |
| Torque Value | 20.0 {204} [177] | 22.5 {230} [200] | 30.0 {306} [266] | 40.0 {408} [355] |

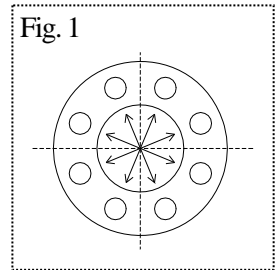

| Nom. Size | 200, 250mm (10", 12") | 300, 350mm (12", 14") |
|--------------|--------------------------|--------------------------|
| Torque value | 55.0 {561} [488] | 60.0 {612} [532] |

Dimension of Insert Bolt A

| Nom. Size | | Bolt A | | | Nut | Washer |
|-----------|--------|--------|-------------------------|-----------------|-----|-----------------|
| d | L | S | | | | |
| 40mm | 1 1/2" | M16 | more than 125mm (4.92") | 35mm (1.38") | M16 | 16mm (0.63") |
| 50mm | 2" | | more than 125mm (4.92") | | | |
| 65mm | 2 1/2" | | more than 130mm (5.12") | | | |
| 80mm | 3" | | more than 130mm (5.12") | | | |
| 100mm | 4" | | more than 145mm (5.71") | | | |
| 125mm | 5" | M20 | more than 165mm (6.50") | 40mm (1.57") | M20 | 20mm (0.79") |
| 150mm | 6" | | more than 175mm (6.89") | | | |
| 200mm | 8" | | more than 190mm (7.48") | | | |
| 250mm | 10" | | more than 220mm (8.66") | | | |
| 300mm | 12" | M22 | more than 245mm (9.65") | M22 | M22 | 22mm (0.87") |
| 350mm | 14" | | more than 250mm (9.82") | | | |

Bolt A

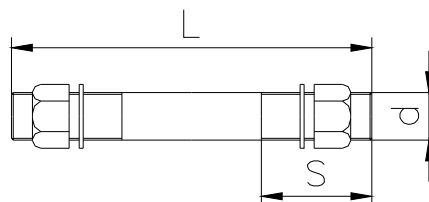



- The parallelism and axial misalignment of the flange surface should be under the values shown in the following table to prevent damage the valve.
(A failure to observe them can cause destruction due to stress application to the pipe.)

Unit : mm (inch)

| Nom. Size | Axial Misalignment | Parallelism (a-b) |
|-----------------------|--------------------|-------------------|
| 50-80mm (2"-3") | 1.0mm (0.04") | 0.8mm (0.03") |
| 100-150mm (4"-6") | 1.0mm (0.04") | 1.0mm (0.04") |
| 200-250mm (8"-10") | 1.5mm (0.06") | 1.0mm (0.04") |

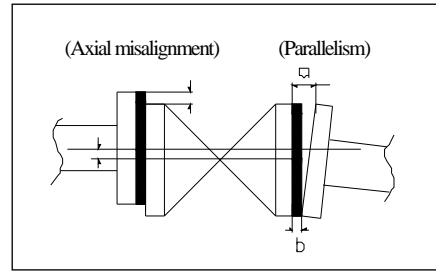

(8) Support setting procedure



- Do not subject the valve to pump vibrations. (The valve may be damaged.)



- Valves must be supported. (The valve may be damaged by the weight of the actuator if it is unsupported.)

Necessary items

- Spanner Wrench
- U-Type Clamp (with bolt)
- Rubber Sheet

Level Installation

Set the stand under the valve.

Spread the rubber sheet on the pipe and secure pipe with U-type clamp.

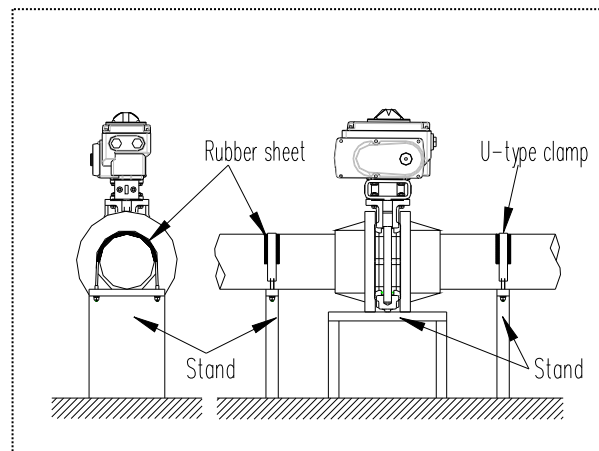





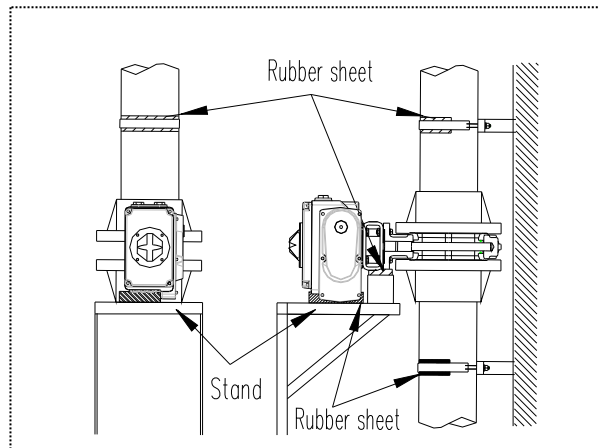

Perpendicular Installation

Spread the rubber sheet under the actuator and connection part of body and actuator.

Spread the rubber sheet on the pipe and secure pipe with U-type clamp.



(9) Electric wiring procedure

- Warning**   - Do not touch any parts on actuator circuit board or terminal block or connect or disconnect wires while the actuator is energized. (Any such practice may result in an electric shock or equipment damage.)
-  - Keep hands and other extremities away from moving parts under all circumstances. (Any such practice may get your hand, arm, or other part of your body caught.)
- Be sure to establish a ground. (A defective ground may result in an electrical shock, fire, or other incident.)
 - At the time of adjustment or inspection, ensure that your hands are free of water and oil. (Any such substance on your hands may result in an electric shock or equipment damage.)
 - Before manual operation, ensure that the actuator is not activated by the motor.
- Caution**   - Do not exceed the rated capacity of limit switch contacts. If you wish to apply very small loads (1-100 mA, 5-30 V), consult our service station nearest to you.
- Do not connect two or more motor-driven valves in series. Also, install a switch (or a relay contact) for each motor-driven valve.
 - Do not use the product near high-voltage wire, inverter, or any other equipment that produces electrical noise or magnetism. (The presence of such nearby may cause malfunction or breakdown.)
-  - Check the integrity of wiring insulation before connecting to the actuator. (Failure to observe this precaution may result in wire damage.)
- Ensure all covers are tightly fastened prior to operation. (Insufficient fastening may allow rainwater, dust, or dirt to come in, resulting in breakdown.)
 - When connecting wires, be sure to observe the connection diagram and make the connections correctly. Moreover, after wiring, ensure that the connections are securely made before turning on the power. (Failure to take this precaution may cause malfunction or breakdown.)
 - Each cover part is sealed with an O-ring. When laying wiring or in similar cases, where the cover is removed and replaced, ensure that the O-ring is installed in the specified location and securely sealed. (Insufficient sealing may cause the actuator to be penetrated by rainwater or other foreign matter, resulting in electric shock or breakdown.)
 - If you wish to use the product outdoors or in any other location exposed to rainwater or other forms of moisture, protect the wiring conduit of the actuator against ingress of rainwater and all other wetness. (Failure to take such a precaution may cause the actuator to be penetrated by rainwater or something similar, resulting in electric shock or breakdown.)
 - In the case of malodor, overheating, or smoking, turn off the power supply immediately. (Continued use despite an abnormality present may result in a fire. If you detect any abnormalities, be sure to consult the dealership where you bought the product or our service station nearest your premises and ask them to perform an inspection.)

Necessary items

-  Spanner Wrench
-  Wire Stripper
-  Crimp-Style Terminal
-  Technical Crimping Tool
-  Connector
-  Screwdriver (+)

*Check supply voltage indicated on the actuator and make sure it is the same as the voltage applied, before completing the wiring.
 (Wiring at different voltages will cause problems in the AV valve.)

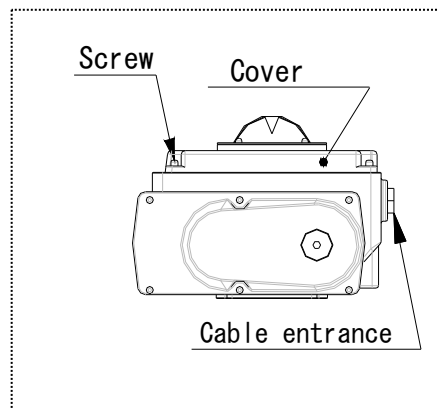

Procedure

- 1) Loosen the screws with a screwdriver (+) and remove the cover from the actuator.
- 2) Remove the plug for cable entrance with a spanner wrench.
- 3) Draw a cable through the connector.
- 4) Strip the cable with a wire stripper.
- 5) Install a Crimp-style terminal on the lead wire with a terminal-crimping tool.
- 6) Connect the terminal board with a screwdriver in accordance with page 5.
*Tighten the screws.
(If not, electric shorts or shocks may occur.)
- 7) Tighten the connector.
(If not, electric shorts or shocks may occur.)
- 8) Tighten above screws with a screwdriver to fix and install the cover of the actuator.
- 9) Connect the earth wire to a good ground.





(10) Operating procedure

- Warning** (Warning icon: exclamation mark in a triangle, crossed out by a red circle with a slash)
- Do not touch any parts on actuator circuit board or terminal block or connect or disconnect wires while the actuator is energized. (Any such practice may result in an electric shock or equipment damage.)
 - Do not operate the manual override while the actuator is energized.
- !** (Warning icon: exclamation mark in a blue circle)
- Keep hands and other extremities away from moving parts under all circumstances. (Any such practice may get your hand, arm, or other part of your body caught.)
 - Be sure to establish a ground. (A defective ground may result in an electrical shock, fire, or other incident.)
 - At the time of adjustment or inspection, ensure that your hands are free of water and oil. (Any such substance on your hands may result in an electric shock or equipment damage.)
- Caution** (Caution icon: exclamation mark in a yellow triangle, crossed out by a red circle with a slash)
- Do not connect two or more motor-driven valves in series. Also, install a switch (or a relay contact) for each motor-driven valve.
 - Do not use the product near a high-voltage wire, inverter or other equipment that produces electrical noise or magnetism. (The presence of such nearby may cause malfunction or breakdown.)
- !** (Caution icon: exclamation mark in a blue circle)
- Check the integrity of wiring insulation before connecting to the actuator. (Failure to observe this precaution may result in wire damage.)
 - Ensure all covers are tightly fastened prior to operation. (Insufficient fastening may allow rainwater, dust, or dirt to come in, resulting in breakdown.)
 - When connecting wires, be sure to observe the connection diagram and make the connections correctly. Moreover, after wiring, ensure that the connections are securely made before turning on the power. (Failure to take this precaution may cause malfunction or breakdown.)
 - Each cover part is sealed with an O-ring. When laying wiring or in any similar cases, where the cover is detached and reattached, ensure that the O-ring is installed in a specified location and securely sealed. (Insufficient sealing may cause the actuator to be penetrated by rainwater or other foreign matter, resulting in electric shock or breakdown.)
 - If you wish to use the product outdoors or in any other location exposed to rainwater or other water drops, protect the wire port of the actuator against ingress of rainwater and something similar. (Failure to take such a precaution may cause the actuator to be penetrated by rainwater or something similar, resulting in electric shock or breakdown.)

  - In the case of malodor, heat-up, or smoking, turn off the power supply immediately. (Continued use despite an abnormality present may result in a fire. If you detect any abnormality, be sure to consult the dealership where you bought the product or our service station nearest your premises, asking them about inspection.)

Manual Operating Procedure

  - Turn off the power source.
(If the power source is turned on during the manual operation, you may be injured.)

- Necessary items
- Spanner Wrench
 - Allen Wrench

Procedure (AOC-0)

- 1) Detach the manual operation lever from actuator.
- 2) Insert manual operation lever in actuator. And, take out the capsule (Black).
- 3) Attach the manual operation lever to the manual operation shaft of the actuator. And, turn the spanner wrench.

Right turn (Clock wise) → Shut direction
 Left turn (Counter clock wise) → Open direction
 *Do not turn the handle forcibly to the right and left full operating positions.
 (If done, problems will develop.)

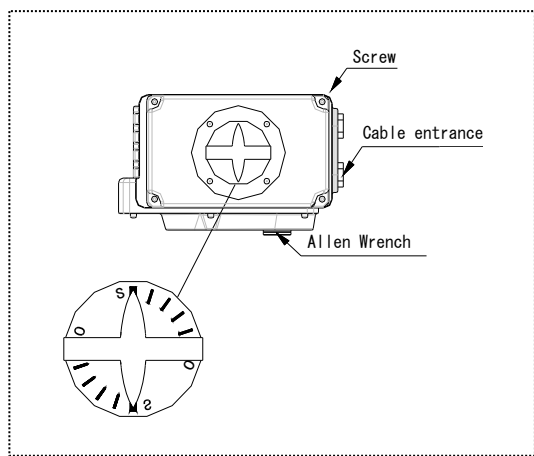



Procedure (AOC-1 – AOC-3)

- 1) Turn the manual operating handle while watching the valve travel indicator, the override will automatically reset.

Right turn (Clock wise) → Shut direction
 Left turn (Counter clock wise) → Open direction
 *Do not turn the handle forcibly to the right and left full operating positions.
 (If not, a trouble will develop.)



Motor-Driven Operating Procedure

  - Do not leave the cover removed from the actuator.
(Coming into contact with a terminal in this state can give you an electric shock.)

- Check to ensure that the spanner is not applied to the end of the manual operation shaft.
(If not, the hexagon wrench will be flown by the rotation of the manual operation shaft, and this may injure you)

- 1) Turn on the power source.
- 2) Set the external switch to “Open” or “Close”, and check to ensure that the valve indicating direction and the operating direction agree with each other.
- 3) Turn off the power source in the state of the full open or shut.

(11) Disassembling method for replacing parts

- Warning**  - Do not disassemble or remodel the actuator.
- Do not touch any parts on actuator circuit board or terminal block or connect or disconnect wires while the actuator is energized. (Any such practice may result in an electric shock or equipment damage.)
- !** - Be sure to conduct a safety check on all hand and power tools to be used before beginning work.
- Wear protective gloves and safety goggles as fluid remain in the valve even if the pipeline is empty. (You may be injured.)
- Do not change or replace valve parts under line pressure.
- Caution**  **!** - Fasten the cover in each cover-equipped part. (Insufficient fastening may allow rainwater, dust, or dirt to come in, resulting in breakdown.)
- The actuator has been adjusted at the factory. If reconfiguration or adjustment is needed, do so correctly according to the relevant operation manual. (Failure to observe this instruction may cause malfunction or breakdown.)
- Each cover part is sealed with an O-ring. When laying wiring or in similar cases, where the cover is removed and replaced, ensure that the O-ring is installed in the specified location and securely sealed. (Insufficient sealing may cause the actuator to be penetrated by rainwater or other foreign matter, resulting in electric shock or breakdown.)

Necessary items

- Jack
- Pipe
- Plate
- Allen Wrench
- Thrust Bearing
- Pliers
- Protective Gloves
- Safety Goggles

Disassembly Procedure

- 1) Completely discharge fluid from pipes.
- 2) Fully close the valve by the motor-driven operation or manual operation.
- 3) Turn off the power source.
- 4) Leave the valve slightly opened with a manual operating lever.
- 5) Loosen the bolts-nuts of piping system and remove them.
- 6) Remove the body part from piping system.
- 7) Loosen the bolt (E) [38] or bolt-nut (A) [39], and remove the actuator.
- 8) To take off the stem holder [8], release 4 self-tapping screws [23] by using screw driver (+).
- 9) <Nominal size 40-100 mm (1 1/2"-4")>
Pull out the stem [7] by hand or pliers.
<Nominal size 125-350 mm (5"-14")>
Attach jack, thrust bearing, plate, and pipe to the valve, and thrust the jack into the stem [7].
Turn the handle of jack to pull out the stem [7].
- 10) Hold flat surface [7] with vise and pull off the valve body [1].
- 11) Remove the O-ring (C) [6].
- 12) Make the disc [2] fully open.
- 13) Insert the screw driver (-) between body [1] and seat [3]. Disc [2] and seat [3] are extruded by using screw driver (-).

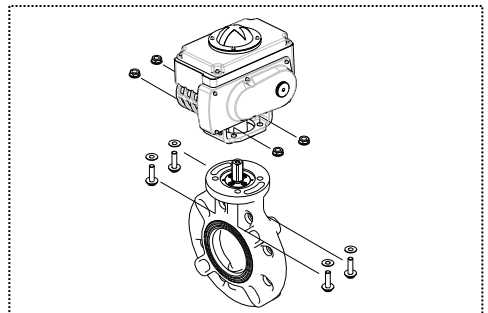
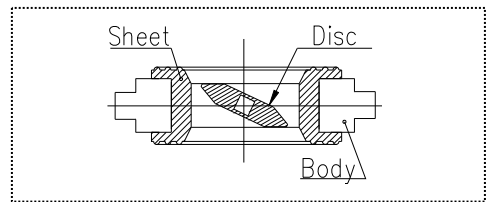
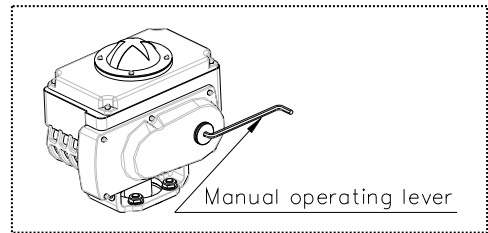

- 14) Remove the disc [2], seat bush A [183] and seat bush B [184] from the seat [3].

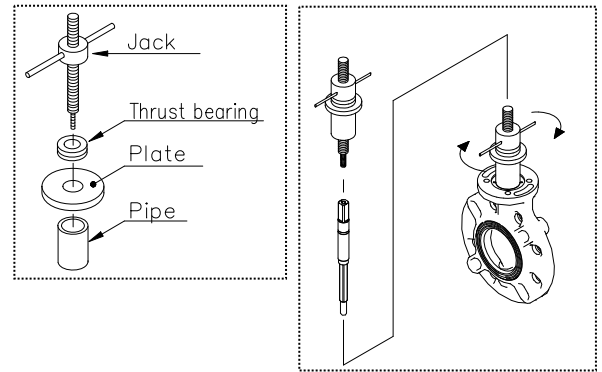

Assembly Procedure

- 1) Before starting assembly, grease (Silicone) should be spread on the O-ring (C) [6] and O-ring (I) [185].
- 2) Put the O-ring (C) [6] onto the stem [7]. Put the O-ring (I) [185] onto the stem bush A [183] and B [184].
- 3) Grease (Silicone) should be spread on the top and bottom disc [2], the stem of the seat [3].
- 4) Put the disc [2], seat bush A [183] and seat bush B [184] onto the seat [3]. "The set of seat - disc" call for combined parts.
- 5) Put it into the state of open the valve slightly. Insert the set of seat - disc [3] into the body [1].

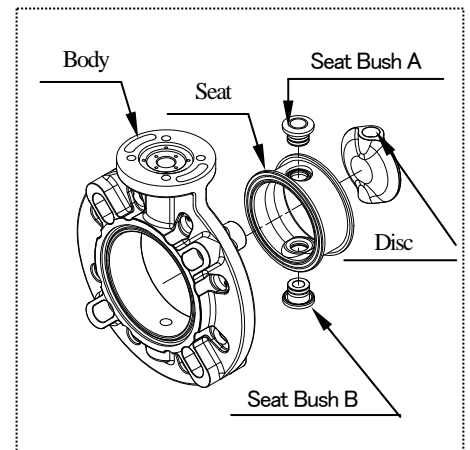

- Make certain stem hole of seat are properly aligned. The upper side stem hole of seat bush A [183] has larger than seat bush B [184] of lower side. When the stem bush is assembled oppositely, the stem [7] cannot be inserted.

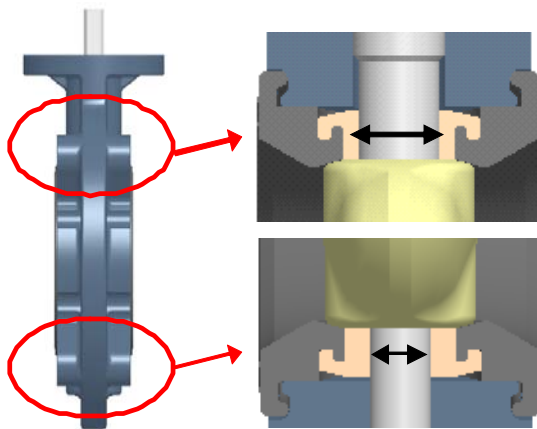

Upper side:
Stem hole is large size

Lower side:
Stem hole is small size



- Make certain tabs are properly aligned.

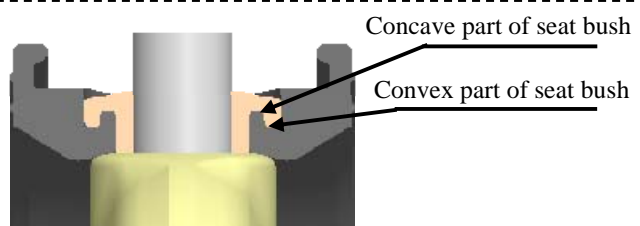

- 6) Insert the stem [7] of the body [1].
- 7) Install the stem holder [8] onto valve body [1] with countersunk holes facing up using 4 screws [157].
- 8) Install the actuator [35] and stand [30] onto the valve body using bolt (E) [38] and bolt-nut (A) [39].
- 9) After assembly, make sure that the valve can be fully opened and closed smoothly.
- 10) Fully open or close the valve by motor-driven operation. (Refer to page 13)

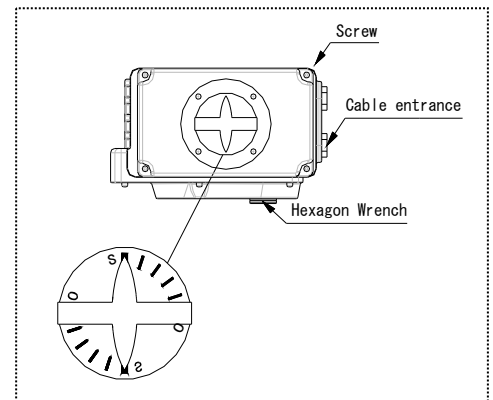

(12) Adjustment limit switch

- Warning** - Shut down the power on the equipment before connecting wires. There are risks of electrical shock depending on the level of operating voltage.
- Caution** - Be sure that the cover is put on during operation.
- If you plan to operate limit switches at 1mA-100mA or 5-30V, consult your nearest Asahi dealer.

Necessary items

- Allen Wrench (3mm)
- Spanner Wrench

Procedure

- 1) Turn off the power source.
- 2) Completely discharge fluid from pipes.
- 3) Loosen screws with spanner wrench, and remove the cover.
- 4) Manually operate (Refer to page 13) the valve at the valve travel (Open) adjuster with a manual operating lever.
- 5) Loosen the locking bolt of cam with an allen wrench.
- 6) Slowly transfer fully open or close side cam with an allen wrench in the direction where this cam should be adjusted.

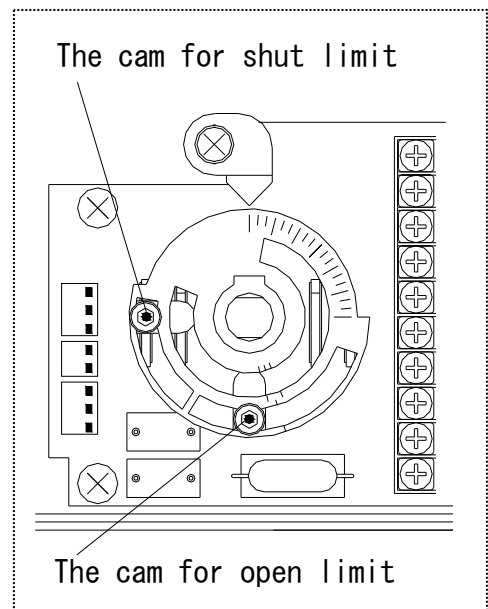

*Do not loose any parts. The cam can be adjusted at existing condition.
(If not, the valve will not operate normally.)

- 7) Check to ensure that the limit switch works.
- 8) Tighten the locking bolt with fixing cam by hand.
- 9) Check to see whether the valve travel is adjusted by manual operation. (Refer to page 13)
When the valve travel is not adjusted, repeat items 4) to 8).
- 10) Remove the allen wrench from the manual operation shaft.
- 11) Tighten the screws of the cover with a wrench.
- 12) Fully open or close the valve by motor-driven operation. (Refer to page 13)
- 13) Check to ensure that travel indicator shows correct position of fully “open” or “shut”.

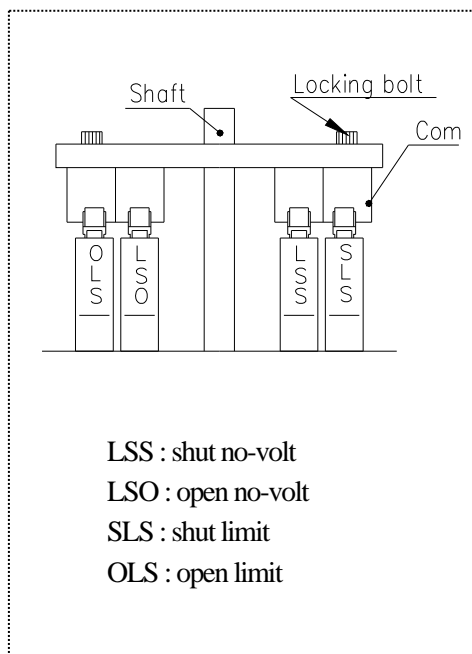

(13) Inspection items

- Perform periodic maintenance. (Leakage may develop due to temperature changes or over periods of prolonged storage, rest or operation.)



| Portion to be Inspected | Inspection Item |
|-------------------------|--|
| Actuator | <ul style="list-style-type: none"> ● Existence of rust, peeling of paint, and dirt in inspection hole of valve ravel indicator. ● Tightening condition of respective threaded portions. (Loose or not) ● Existence of rust and corrosion around the limit switch, and existence of internal disconnection. ● Existence of rust and corrosion of terminal board, and existence of disconnection. ● Existence of abnormality in opening and closing operating sounds. ● Smooth operation of manual handle. |
| Note : | It is unnecessary to supply oil to the actuator. |
| Valve | <ul style="list-style-type: none"> ● Existence of scratches, cracks, deformation, and discoloring. ● Existence of leakage from the valve to the outside. ● Existence of leakage when the valve is opened fully at right or left. |

(14) Troubleshooting

| Problem | Cause | Treatment |
|--|---|---|
| The handle is not (can't be) turned when the valve is operated manually. | The valve has already been opened fully. | Turn the handle in the reverse direction. |
| | The valve is kept as it is electrified in the direction reverse to the handle operating direction. | Turn of the power source. |
| | Foreign matter is in the valve. | Disassemble the valve to remove foreign matter. (Refer to page 8) |
| | The torque of the valve is increased by the piping stress. | Remove the piping stress. |
| | The torque is increased by the influence (Temperature, Components, Pressure) of fluid on the valve. | Check service condition. (Refer to page 5) |
| The valve does not operate by motor-driven operations | The power source of the control panel is turned off. | Turn on the power source. |
| | The actuator is disconnected. | Check the connection again. (Refer to page 7) |
| | Open and close are electrified Simultaneously | |
| | The actuator is connected wrongly. | |
| The valve does not operate by motor-driven operations | The supply voltage is wrong. | Check voltage with a tester and set specified voltage. |
| | The voltage is low. | |
| | Foreign matter is in the valve. | Disassemble the valve to remove foreign matter. (Refer to page 8) |
| | The torque of the valve is increased by the piping stress. | Remove the piping stress. |
| | The torque is increased by the influence (Temperature, Components, Pressure) of fluid on the valve. | Check service condition. (Refer to page 5) |
| Fluid leaks from the valve even when the valve is closed fully. | The seat is worn. | Replace the seat with a new one. (Refer to page 15) |
| | The seat and disc are scratched. | Replace the scratched seat and ball with new ones. (Refer to page 15) |
| | Foreign matter is in the valve. | Discharge the foreign matter from the valve by opening and closing the valve several times. |
| | Adjustment of limit switch is wrong. | Adjustment limit switch. |
| | The voltage is low. | Check voltage with a tester and set specified voltage. |

| Problem | Cause | Treatment |
|---|--|--|
| Fluid leaks from the valve. | The O-ring is scratched or worn. | Replace the O-ring with a new one. (Refer to page 15) |
| | The O-ring is projected from the groove. | |
| | The sliding face or the fixed face of the O-ring is scratched or worn. | Replace the sliding face or the fixed face with a new one. (Refer to page 15) |
| The actuator operates, but the valve does not open or shut. | The stem or the joint is broken. | Replace the stem or the joint with a new one. |
| | The engagement between the stem and the ball is broken. | Replace the engagement with a new one. |
| An Unusual signal comes out. | Limit switch is broken. | Replace the limit switch. |
| | The cam of limit switch and the cam of double limit switch approach it too much. | Adjust cam correctly. |

(15) Handling of residual and waste materials

  - Make sure to consult a waste treatment dealer for recommendations on the proper disposal of plastic valves. (Poisonous gas is generated when the valve is burned improperly.)

**Butterfly Valves
Electric Actuated Type T**

[Automatic Valve]



ASAHI AV VALVES

Distributor

<http://www.asahi-yukizai.co.jp/en/>