

User's Guide



## Digital Viscotesters

**Model 345060 High Range (0.3 to 4000 dPas)**

**Model 345055 Low Range (1.5 to 330 mPas)**

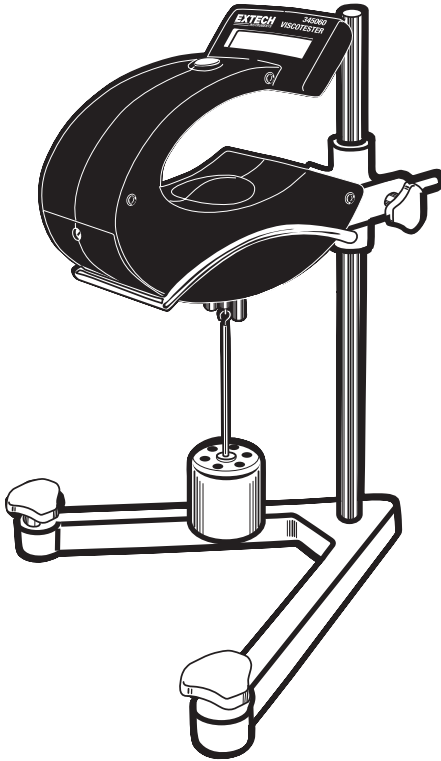

### ***Introduction***

---

Congratulations on your purchase of the Extech Digital Viscotester. The Extech Viscotesters are rotational viscometers with a digital display specially suited for fast tests and comparative measurements on liquids. Careful use of this meter will provide years of reliable service.

# Specifications

Display	Multifunction Digital Display
Drive	4V rated DC Servo Motor
Rotational Drive Speed	62.5 RPM
Measuring Range	345055 1.5 to 330 mPas (1.5 to 330cP) 345060 0.3 to 4000 dPas (30 to 400,000cP)
Accuracy	± 5% of full scale †
Repeatability	±1% ‡
Sample Temperature	300°F (150°C) maximum
Sample Volume	approx. 5.3oz (150 ml)
Power	Four (4) 1.5V 'AA' batteries
Operating Temperature	50 to 104°F (10 to 40°C)
Rotor Dimensions	Refer to the Rotor Specifications section
Weight	Case and accessories: 4.4 lbs (2 kg)

† Published accuracy assumes the use of supplied rotors

‡ For two consecutive measurements under identical measuring conditions

## Rotor Specifications

Rotor Material: Anodized aluminum or stainless steel

Rotor Accuracy: ±3% Full Scale

Rotor Dimensions		
Rotor No.	D	h
1	0.94" (24.0mm)	2.08" (53.0mm)
2	0.59" (15.0mm)	0.04" (1.00mm)
3	1.77" (45.1mm)	1.85" (47.0mm)
4	3.07" (78.0mm)	1.81" (46.0mm)
5	2.40" (61.2mm)	1.41" (36.0mm)

Rotor Measurement Ranges		
Display	Model 345055	Rotor
R4	1.5 to 33mPas	4
R5	15 to 150 mPas	5
R3	50 to 330 mPas	3
Model 345060		
R3	0.3 to 13dPas	3
R1	3 to 150 dPas	1
R2	100 to 4000dPas	2

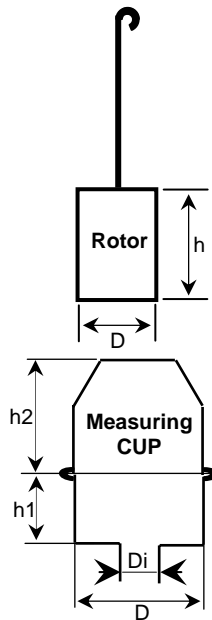

## Cup Specifications

Material: Stainless steel or anodized aluminum

Sample volume: approx. 400ml

Measuring Cup Dimensions					
Type	D	Di	h1	h2	Model
A	3.54"(90mm)	n/a	2.97"(75.5mm)	3.75"(95.5mm)	345055
B	3.54"(90mm)	1.18"(30mm)	2.97"(75.5mm)	3.75" (95.5mm)	345055
3	2.07"(52.6mm)	n/a	2.95"(75mm) (h1+h2)		345060

## Description

1. Function button
2. Digital display
3. Stand clamp
4. Rotor
5. Support stand (optional)
6. Point of orientation
7. Battery compartment screw
8. Battery container
9. Stand mounts
10. Clamps for Cups A & B (345055)
11. Drive shaft

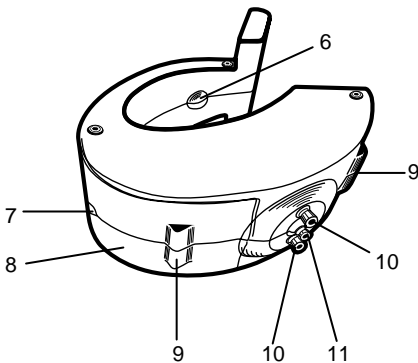
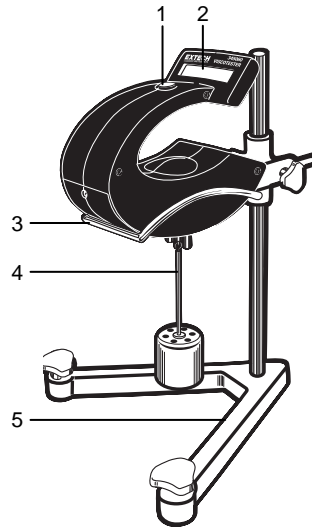

## Operation

### Powering the meter

Firmly press and hold the function button until the model number appears on the display (VT1 for the 345055, VT2 for the 345060). The model number will switch off and the zero adjust display will appear.

### Zero Adjustment

#### ZERO ADJUST?

When the zero adjustment display appears the user has 3 seconds to press the function button to activate the automatic zero adjustment. Press the button again when the model number appears on the display. The zero adjustment will now run (approx. 13 second test time during which the display will show 'CAL WAIT'). The zero adjustment eliminates display offset. The adjustment is made with the device in the measurement position without a rotor connected. To skip the adjustment, wait 3 seconds and the 'MEASUREMENT' display will appear.

### Measurement Display

When 'MEASUREMENT' appears the unit is ready to measure.

**MEASUREMENT**

## Viscosity Measurements

1. Press the function button to start measuring. The meter powers up in the range that was in use when the instrument was last turned off. The motor turns continuously while measuring.
2. Select the rotor type by briefly pressing the function button (while in the measurement mode) and selecting another rotor type (Model 345055: R3, R4, R5 and Model 345060: R1, R2, R3). The display 'RX wait' will appear for approx. 3 seconds and the measurements will be made using the newly selected rotor measurement range (always verify that the connected rotor matches the type selected on display). The rotor type is displayed on the left side of the display; the viscosity measurement is displayed on the right.
3. Select one of the four measurement methods outlined in the section 'Measurement Methods' later in this manual.
4. Suspend the rotor and, if required, connect the measuring cup to the clamps.
5. Immerse the rotor into the test substance up to the dip mark (on the rotor shaft).
6. Hold the unit horizontally by hand or with the optional stand (use of the optional stand is recommended). If held by hand, hold the unit with the forefinger at the point of orientation (see diagram).
7. Read the measured value on the display. The value on the left side of the display represents the rotor type (R1 to R5). The value on right is the viscosity measurement. By pressing the function button momentarily (1 second) the motor shuts off and the last measured value calculated for the viscosity will be "frozen". By pressing the function button again the measurement will be restarted in the range last used.

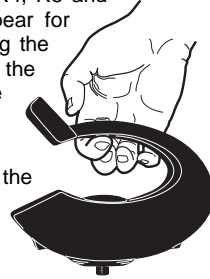

## Turning the meter OFF

### SERVICE IN 300h

From the measurement mode, firmly press and hold the function button for approx. 3 seconds to turn the instrument off. The display will then alert the user as to the number of hours (h) remaining before a calibration (service) is due. The display will then switch off.

## Error Message Displays

### RX XX! dPas

Minimum measuring range exceeded; use a larger rotor.

### RX >XX dPas

Maximum measuring range exceeded; use a smaller rotor.

### SAFETY CUT OFF

Maximum range exceeded for 5 subsequent measurements. The error message appears and the motor stops.

### OVERLOAD

The electrical current limitation has been reached. The unit automatically switches off. Have the unit serviced.

## Measurement Methods

### 1. Measurement Method 1

The Rotor is immersed in any vessel. The distance between the rotor and the wall of the vessel should not be smaller than the diameter of the rotor.

Advantages: Ideal for comparing test solutions. Ease of measurement and cleaning.

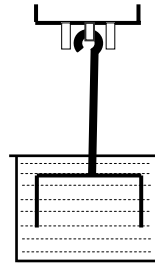

Method 1

### 2. Measurement Method 2 (345055 only)

Solution under test is placed in measuring Cup A.

Advantages: Repeatable measurement conditions and temperature control. Small sample volume required.

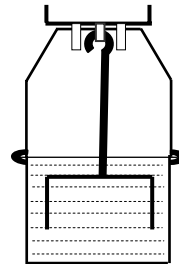

Method 2

### 3. Measurement Method 3 (345055 only)

Measuring Cup B is immersed in solution to be measured.

Advantage: Measurement made directly in storage container.

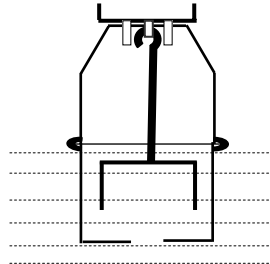

Method 3

### 4. Measurement Method 4 (345060 only)

Measurements are made in Cup 3. Temperature control in circular bath is possible.

Advantages: Repeatable measurement conditions. Smallest sample solution required (150ml). Exact temperature control.

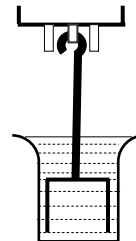

Method 4

## Measurement Principle

With the rotor rotating at a constant speed, immersed in the liquid to be tested, the rotational resistance (viscosity) of the liquid is measured and displayed directly on the digital display.

## Technology

The drive axis is connected to one side of a spiral spring and the rotor axis to the other end of the spring. When rotating with no load applied, the ends of the spring pass a light sensor at the same time (since the spring is not deflected). With a load applied, i.e. when the rotor is immersed in liquid, the spring is twisted and the spring ends do not break the light sensor at the same time. The difference is measured by the meter and readings are calculated and displayed.

## Viscosity Values of Selected Substances

In order to facilitate the selection of a suitable rotor, the following table contains standard values for the viscosity of selected substances at a temperature of 20°C.

Substance	Viscosity [mPas]
Water	1†
Sucrose solution	6 (40g in 100 ml Water)
Coffee cream	10
Light crude oil	10
Glycol	20
Olive oil	84
Lubricant oil 300 bis	800
Lubricant oil 50 bis	1,000
Rhizinus oil	1,500
Honey	10,000
Bitumen	100,000,000†

† Beyond the measuring range of the Models 345055 & 345060

## Conversions

1 mPas (milli Pascal second) = 1 cP (centi Poise)

1 dPas (deci Pascal second) = 1 P (Poise)

1 dPas (deci Pascal second) = 100 mPas

## Temperature Influence on Viscosity

Viscosity is temperature dependant and, therefore, the temperature of the test material should be controlled. The temperature should be recorded for each viscosity measurement, e.g. 26.3°C = 160 mPas (i.e.: the viscosity at 26.3°C is 160 milli Pascalseconds). It is possible to determine the viscosity dependence on temperature by performing viscosity measurements at two different temperatures and calculating the corresponding viscosity value in relation to the reference temperature.

### Example

For example, at 18°C a measurement is taken and the reading is 200 mPas. Another reading is taken at 24°C and the reading is 170 mPas. This 6° change in temperature (24 – 18 = 6°C) corresponds to a change in viscosity of 30mPas (200 – 170 = 30 mPas). In this case, the viscosity changes 5mPas for each degree (refer to the table below).

Note: 20°C is used as the reference temperature for instrument calibration.

Temperature (°C)	Viscosity (mPa seconds)
18	200
20	190
22	180
24	170
26	160
28	150

## Comparing Viscometer Readings

Test results of purely viscous (Newtonian) liquids (e.g. mineral oils, sugar solutions, glycerine) obtained with a viscotester can be compared directly with the results of other viscometers. Most liquids, however, have a different viscosity measurement under differing shearing conditions (size and design of the rotors, the rotor speed, etc). For this reason, test results of non-Newtonian liquids obtained by two different types of viscometers are usually not comparable. A viscometer with variable shearing conditions is required to perform such comparisons. Note that Models 345055 and 345060 do not have a variable shearing function.

## Verification of the Viscotester

In order to verify the functionality of the viscotester, tests on Newtonian liquids should be performed regularly. For this, a standard liquid corresponding to the measuring range of the rotor must be used. The measurement must be made in the original measuring cup that was supplied with the standard. The value which is displayed on the viscotester must correspond to the value indicated on the provided certificate for the standard liquid within the specified tolerance (accuracy of the measuring system + accuracy for the certified viscosity). Since viscosity depends largely on temperature, the measurement must be made at the temperature indicated for the viscosity of the standard liquid.

## Battery Replacement

### Change Batteries

If the viscotester does not turn on or if the 'Change Batteries' display appears, the four (4) 1.5V 'AA' batteries must be replaced.

1. Unlock the battery compartment by backing off the compartment locking screw approximately ½ turn.
2. Once the compartment is unlocked, carefully pry off the compartment cover.
3. Replace the 'AA' batteries observing polarity.
4. Re-attach the compartment cover and tighten the locking screw.

## Calibration and Repair Services

### CAL RECOMMENDED

If the 'CAL RECOMMENDED' display appears, the unit must be returned for calibration or other servicing.

Extech offers repair and calibration services for the products we sell. Extech also provides NIST certification for most products. Call the Customer Service Department for information on calibration services available for this product. Extech recommends that annual calibrations be performed to verify meter performance and accuracy.

## Warranty

*EXTECH INSTRUMENTS CORPORATION warrants this instrument to be free of defects in parts and workmanship for one year from date of shipment (a six month limited warranty applies on sensors and cables). If it should become necessary to return the instrument for service during or beyond the warranty period, contact the Customer Service Department at (781) 890-7440 ext. 210 for authorization or visit our website at [www.extech.com](http://www.extech.com) (click on 'Contact Extech' and go to 'Service Department' to request an RA number). A Return Authorization (RA) number must be issued before any product is returned to Extech. The sender is responsible for shipping charges, freight, insurance and proper packaging to prevent damage in transit. This warranty does not apply to defects resulting from action of the user such as misuse, improper wiring, operation outside of specification, improper maintenance or repair, or unauthorized modification. Extech specifically disclaims any implied warranties or merchantability or fitness for a specific purpose and will not be liable for any direct, indirect, incidental or consequential damages. Extech's total liability is limited to repair or replacement of the product. The warranty set forth above is inclusive and no other warranty, whether written or oral, is expressed or implied.*



### Support Hotline (781) 890-7440

Tech support: Ext. 200; Email: [support@extech.com](mailto:support@extech.com)  
Repair>Returns: Ext. 210; Email: [repair@extech.com](mailto:repair@extech.com)  
Website: [www.extech.com](http://www.extech.com)

### Copyright © 2005 Extech Instruments Corporation

All rights reserved including the right of reproduction in whole or in part in any form.