

OIL INDIA LIMITED
(A Government of India Enterprise)
P.O. Duliajan-786602, Assam, India
E-mail: material@oilindia.in

INVITATION FOR BID. LOCAL COMPETITIVE BID

OIL INDIA LIMITED invites Local Competitive Bid (LCB) through its e-procurement portal <https://etender.srm.oilindia.in/irj/portal> for the following items:

E-Tender No	Bid Closing/Opening Date	Item Description
SDI8275P16 Dtd. 24.08.2015 (Single Stage Composite Bid System)	19.10.2015	Remote Ignition System
SDI8400P16 Dtd. 31.08.2015 (Single Stage Composite Bid System)	19.10.2015	Lubricating Oil

Tender fee (Non-refundable): Rs 1,000.00; Bid Closing/Opening Time: **(11 Hrs.) IST/(14 Hrs.) IST**; Period of sale of documents: **Till one week prior to bid closing date**. The complete bid documents and details for purchasing bid documents, participation in E-tenders are available on OIL's e-procurement portal <https://etender.srm.oilindia.in/irj/portal> as well as OIL's website www.oil-india.com.

NOTE: All addenda, Corrigenda, time extension etc. to the tenders will be hosted on above website and e-portal only and no separate notification shall be issued in the press. Bidders should regularly visit above website and e-portal to keep themselves updated.

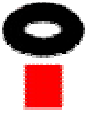

OIL INDIA LIMITED
(A Government of India Enterprises)
PO : Duliajan – 786602
Assam (India)

TELEPHONE NO: (91-374) 2808719

FAX NO: (91-374) 2800533

Email: Sristi_jallan@oilindia.in ; erp_mm@oilindia.in

FORWARDING LETTER

Tender No. : SDI8275P16 Dtd. 24.08.2015.
Tender Fee : Rs 1,000.00
Bid Security Amount : 19,700.00
Bidding Type : SINGLE STAGE COMPOSITE BID SYSTEM
Bid Closing on : As mentioned in the e-portal
Bid Opening on : -do-
Performance Security : Applicable
Integrity Pact : Not Applicable.

OIL invites Bids for **Supply of Remote Ignition System for LPG OTP Flares** through its e-Procurement site under **SINGLE STAGE COMPOSITE BID SYSTEM**. The bidding documents and other terms and conditions are available at Booklet No. MM/LOCAL/E-01/2005 for E-Procurement LCB Tenders. The prescribed Bid Forms for submission of bids are available in the Technical RFx -> External Area -> Tender Documents

The general details of tender can be viewed by opening the RFx [Tender] under RFx and Auctions.. The details of items tendered can be **found in the Item Data and details uploaded under Technical RFX.**

The tender will be governed by:

- a) “General Terms & Conditions” for e-Procurement as per Booklet No. MM/LOCAL/E-01/2005 for E-Procurement LCB Tenders.
- b) Technical specifications and Quantity as per **Annexure – 1A**.
- c) The prescribed Bid Forms for submission of bids are available in the Technical RFx -> External Area -> Tender Documents.
- d) In the event of receipt of only a single offer against the tender within B.C. date, OIL reserves the right to extend the B.C. date as deemed fit by the Company. During the extended period, the bidders who have already submitted the bids on or before the original B.C. date, shall not be permitted to revise their quotation.
- e) All corrigenda, addenda, amendments, time extension, clarifications etc. To the tender will be hoisted on OIL’s website (www.oil-india.com) and in the e-portal (<https://etenders.srm.oilindia.in/irj/portal>) only and no separate notification shall be issued

in the press. Prospective bidders are requested to regularly visit the website and e-portal to keep themselves updated.

- f) Any sum of money due and payable to the contractor (including Security Deposit refundable to them) under this or any other contract may be appropriated by Oil India Limited and set-off against any claim of Oil India Limited (or such other person or persons contracting through Oil India Limited) for payment of sum of money arising out of this contract or under any other contract made by the contractor with Oil India Limited (or such other person or persons contracting through Oil India Limited).
- g) Bidder are advised to fill up the Technical bid check list (**Annexure EEE**) and Response sheet (**Annexure FFF**) given in MS excel format in Technical RFX -> External Area -> Tender Documents. The above filled up document to be uploaded in the **Technical RFX** Response.

Special Note:

1.0 General Qualification Criteria:

In addition to the general BRC/BEC, following criteria on Bidders' Experience and their financial capabilities shall be considered (**Documentary evidence to be provided along with the bid in Technical RFX -> External Area -> Tender Documents**) as on the Bid Closing Date:

Criteria	Complied / Not Complied.
	Documentary evidence submitted / not submitted
a) Bidder should have experience of successfully executing atleast one similar order for Remote Ignition System for a minimum value of Rs 5.91 Lakhs during last 3 years as on the bid closing date.	
b) Annual financial turnover of the firm in any of the last 3 financial years or current financial year should not be less than Rs 19.70 Lakhs.	

Note: Documentary evidence in respect of the above should be submitted in the form of copies of relevant Purchase Orders along with copies of any of the documents in respect of satisfactory execution of each of those Purchase Orders, such as – (i) Satisfactory Inspection Report (OR) (ii) Satisfactory Supply Completion / Installation Report (OR) (iii) Consignee Received Delivery Challans (OR) (iv) Central Excise Gate Pass / Tax , Invoices issued under relevant rules of Central Excise / VAT (OR) (v) any other documentary evidence that can substantiate the satisfactory execution of each of the purchase orders cited above. For Annual financial turnover enclose the audited Annual Reports or balance sheet certified by a chartered accountant.

2.0 Vendors having OIL’s User ID & password shall purchase bid documents on-line through OIL’s electronic Payment Gateway.

Vendors who do not have OIL’s User ID & password shall obtain User ID & password through online vendor registration system in e-portal and can subsequently purchase bid documents through OIL’s electronic Payment Gateway.

Alternatively application showing full address/email address with Tender Fee (Non-refundable) of Rs. 1,000.00 in favour of M/s Oil India Limited and payable at Duliajan is to be sent to Head-Materials, Oil India Limited, P.O. Duliajan, Assam-786602. Application shall be accepted only upto 08.09.2015 (or as amended in e-portal). The envelope containing the application for participation should clearly indicate “REQUEST FOR ISSUE OF USER ID AND PASSWORD FOR E TENDER NO ...” for easy identification and timely issue of user ID and password. On receipt of requisite tender fee, USER_ID and initial PASSWORD will be communicated to the bidder (through e-mail) and will be allowed to participate in the tender through OIL’s e- Procurement portal. No physical tender documents will be provided. Details of NIT can be viewed using “Guest Login” provided in the e-Procurement portal. The link to e-Procurement portal has been also provided through OIL’s web site www.oil-india.com.

NOTE:

a) Tender Fee may also be paid online upto one week prior to the bid closing date (or as amended in e-portal).

b) PSUs and MSE units are provided tender documents Free of Cost (as per govt guidelines), however they have to apply to OIL's designated office to issue the tender documents before the last date of sale of tender document mentioned in the tender.

3.0 Please note that all tender forms and supporting documents are to be submitted through OIL’s e-Procurement site only except following documents which are to be submitted manually in sealed envelope super scribed with **Tender no.** and **Due date** to **Head Materials, Materials Department, Oil India Limited, Duliajan - 786602, Assam** on or before the Bid Closing Date and Time mentioned in the Tender.

- a) **Original Bid Security**
- b) **Detailed Catalogue (if any)**
- c) **Any other document required to be submitted in original as per tender requirement**

All documents submitted in physical form should be signed on all pages by the authorised signatory of the bidder and to be submitted in triplicate.

4.0 Benefits to Micro & Small Enterprises (MSEs) as per prevailing Govt guidelines as applicable on B.C date shall be given. MSEs who are interested in availing the benefits will upload with their offer proof of their being MSE registered for the item tendered. The MSE are also required to upload scanned copies of relevant documents indicating details of registration alongwith validity, name of the registering organization and details of the item, ownership etc., failing which, their offer may not be liable for consideration of benefits to MSEs.

5.0 Bidders are requested to examine all instructions, forms, terms and specifications in the bid. Failure to furnish all information required as per the NIT or submission of offers not substantially responsive to the bid in every respect will be at the bidders risk and may result in rejection of its offer without seeking any clarifications.

6.0 Bidders must ensure that their bid is uploaded in the system before the tender closing date and time. Also, they must ensure that above documents which are to be submitted in a sealed envelope are also submitted at the above mentioned address before the bid closing date and time failing which the offer shall be rejected.

7.0 Bid must be submitted electronically only through OIL’s e-procurement portal. Bid submitted in any other form will be rejected.

8.0 The tender shall be governed by the Bid Rejection & Bid Evaluation Criteria given in enclosed **Annexure-CCC**. However, if any of the Clauses of the Bid Rejection Criteria / Bid Evaluation Criteria (as per **Annexure-CCC**) contradict the Clauses of the tender and / or “General Terms & Conditions” as per Booklet No. MM/LOCAL/E-01/2005 for E-procurement (LCB Tenders) elsewhere, those in the BEC / BRC shall prevail.

9.0 To ascertain the substantial responsiveness of the bid OIL reserves the right to ask the bidder for clarification in respect of clauses covered under BRC also and such clarifications fulfilling the BRC clauses in toto must be received on or before the deadline given by the company, failing which the offer will be summarily rejected.

10.0 Please do refer the User Manual provided on the portal on the procedure How to create Response for submitting offer.

NOTE:

Bidders should submit their bids (preferably in tabular form) explicitly mentioning compliance / non compliance to all the NIT terms and conditions of NIT.

Yours Faithfully

Sd-

(S. Jallan)

**PURCHASE OFFICER (IP)
FOR HEAD-MATERIALS**

Tender No & Date: SDI8275P16 Dtd. 24.08.2015

BID REJECTION CRITERIA (BRC) / BID EVALUATION CRITERIA (BEC)

The following BRC/BEC will govern the evaluation of the bids received against this tender. Bids that do not comply with stipulated BRC/BEC in full will be treated as non responsive and such bids shall prima-facie be rejected. Bid evaluation will be done only for those bids that pass through the “Bid Rejection Criteria” as stipulated in this document.

Other terms and conditions of the enquiry shall be as per General Terms and Conditions vide MM/LOCAL/E-01/2005 for E-Procurement LCB Tenders. However, if any of the Clauses of the Bid Rejection Criteria / Bid Evaluation Criteria (BRC / BEC) contradict the Clauses of the tender or MM/LOCAL/E-01/2005 elsewhere, those in the BRC / BEC shall prevail.

<u>Criteria</u>	Complied / Not Complied. (Remarks if any)
<p>1.0 BID REJECTION CRITERIA (BRC):</p> <p>The bid shall conform generally to the terms and conditions given in this document. Notwithstanding the general conformity of the bids to the stipulated specifications, the following requirements will have to be particularly met by the Bidders without which the same will be considered as non-responsive and rejected.</p> <p>A) TECHNICAL:</p> <p>i) The bidder must be the OEM (Original Equipment manufacturer) or OEMs authorized dealer. In case of bidders other than OEM, valid authorization dealership certificate from the OEM must be submitted along with the offer.</p> <p>ii) The bidder must quote for both the items i.e. both for supply, installation & commissioning.</p> <p>B) COMMERCIAL:</p> <p>i). Validity of the bid shall be minimum 120 days from the Bid Closing Date.</p> <p>ii). Bid security: The bid must be accompanied by Bid Security of Rs 19,700.00 in OIL's prescribed format as Bank Guarantee or a Bank Draft/Cashier cheque in favour of OIL. The Bid Security may be submitted manually in sealed envelope superscribed with Tender no. and Bid Closing date to Head Materials, Materials Department, Oil India Limited, Duliajan- 786602, Assam on or before the Bid Closing Date and Time mentioned in the Tender. The Bank Guarantee towards Bid Security shall be valid for 10 months from Bid closing date. (i.e. upto <u>19.08.2016</u>).</p>	

Bid Security may also be paid online on or before the Bid Closing Date and Time mentioned in the Tender.

If bid security in ORIGINAL of above mentioned Amount and Validity is not received or paid online within bid closing date and time, the bid submitted through electronic form will be rejected without any further consideration.

For exemption for submission of Bid Security, please refer Clause No. 8.8 of General Terms and Conditions vide MM/LOCAL/E-01/2005 for E-Procurement LCB Tenders.

The format of Bank Guarantee towards Bid Security (Annexure – VII) has been amended to Annexure – VII (Revised) and bidders should submit Bank Guarantee towards Bid Security as per Annexure – VII (Revised) only.

In case of extension of Bid Closing date against the tender where a bidder has already submitted his bid with requisite bid security validity within the original B.C. Date, such bidders will extend validity of bid security covering the extended period of the bid closing date.

iii). Performance Security:

The successful Bidder will have to provide Performance Security @ 10% of order value. The Performance Security must be valid for one year from the date of successful commissioning of the equipment or 18 months from the date of despatch whichever is earlier

The validity requirement of Performance Security is assuming despatch within stipulated delivery period and confirmation to all terms and conditions of order. In case of any delay in despatch or non-confirmation to all terms and conditions of order, validity of the Performance Security is to be extended suitably as advised by OIL.

For exemption for submission of Performance Security, please refer Clause No. 9.12 of General Terms and Conditions vide MM/LOCAL/E-01/2005 for E-Procurement LCB Tenders.

iv). *The Bank Guarantee should be allowed to be encashed at all branches within India.*

v). The prices offered will have to be firm through delivery and not subject to variation on any account. A bid submitted with an adjustable price will be treated as non-responsive and rejected.

vi). Bids received after the bid closing date and time will be rejected. Similarly, modifications to bids received after the bid closing date & time will not be considered.

- vii). All the Bids must be Digitally Signed using “Class 3” digital certificate with Organisation’s name (*e-commerce application*) as per Indian IT Act obtained from the licensed Certifying Authorities operating under the Root Certifying Authority of India (RCAI), Controller of Certifying Authorities (CCA) of India. The bid signed using other than “Class 3 with Organisation’s Name” digital certificate, will be rejected.
- viii). Price should be maintained in the “online price schedule” only. The price submitted other than the “online price schedule” shall not be considered.

2.0 BID EVALUATION CRITERIA (BEC)

The bids conforming to the terms and conditions stipulated in the tender and considered to be responsive after subjecting to the Bid Rejection Criteria as well as verification of original of any or all documents/ documentary evidences pertaining to BRC, will be considered for further evaluation as per the Bid Evaluation Criteria given below.

A) TECHNICAL:

- i) All the items will be procured from a single party. Therefore, the bidder who emerges out to be L1 collectively for Supply, Installation & Commissioning will be the successful bidder.

B) COMMERCIAL:

- i). To evaluate the inter-se-ranking of the offers, Assam Entry Tax on purchase value will be loaded as per prevailing Govt. of Assam guidelines as applicable on bid closing date. Bidders may check this with the appropriate authority while submitting their offer.
- ii). To ascertain the substantial responsiveness of the bid OIL reserves the right to ask the bidder for clarification in respect of clauses covered under BRC also and such clarifications fulfilling the BRC clauses in toto must be received on or before the deadline given by the company, failing which the offer will be summarily rejected.

NOTE:

Bidders should submit their bids (preferably in tabular form) explicitly mentioning compliance / non compliance to all the NIT terms and conditions of NIT.

-----XXXX-----

TECHNICAL SPECIFICATIONS WITH QUANTITY

Tender No & Date: SDI8275P16 Dtd. 24.08.2015

	Complied / Not Complied. (Remarks if any)
<p>ITEM NO. 10, REMOTE IGNITION SYSTEM FOR LPG OTP FLARE, (QTY. – 1NO)</p> <p>[A] Pilot Burner Assembly: The pilot burner assembly shall consists of the following-</p> <ol style="list-style-type: none"> 1. Pilot gas burner & Accessories shall be made of SS 310 2. End connections with Companion flanges for Pilot Gas Pipe shall be made of SA 105 3. Line Size: ½ inch for continuous pilot flame & Line Size: 1 inch for carrying the HV spark to the pilot burner 4. Ignitor assembly (not less than 3 Meters) 5. Attachment/support cleats to burner if any 6. Burner assembly shall be supplied with low pressure gas regulator & manual shut-off valve <p>[B] High Energy Ignition Panel (Auto Ignition System), Flame Proof and following shall be housed:</p> <ol style="list-style-type: none"> 1. An ignition transformer 2. Electrical components for ignition and flame sensing of the pilot burner 3. Power ON/OFF Auto-manual selector switch 4. Manual ignition & Emergency Stop push buttons 5. Indication lamps for Power ON & Pilot Flame ON / Failure. 6. The panel shall be Skid mounted, open type (with canopy for protection from rain and sun at the top) 7. Potential free contact with rating of 5 Amps shall be provided for repeat signals to control room for flame failure alarm indication 8. Panel rating shall be IP56 or higher 9. Suitable cable entry arrangement & adequate no of cable gland shall be provided. <p>[C] Earthing system: Supplier shall provide proper earthling system for the Control panel.</p> <p>[D] Ignition and Flame Sensor</p> <ol style="list-style-type: none"> 1. The ignition shall be approximately 100 Meter away from the Pilot Burner at flare pit. Suitable piping shall be provided to carry the HV spark to the pilot burner from the ignition sparking point. 2. Suitable Flame sensor shall be provided for Open Type Flare Pit (Flare capacity of 4.5 MMSCUM/D). 3. All Junction Boxes shall be Flameproof. <p>[E] Accessories: Any other Accessories required to complete the system, but not limited to all the items as per the specifications provided such that the offered system is functionally and operationally complete in all respect.</p>	

Technical Details:

1. Location: Near LPG Plant flare pit, Duliajan, Assam, India.
2. Flare Line Size: 4-Inch
3. Line Pressure: above 11.2Kg/Cm²
4. Capacity: 4-4.5 MMSCUM/D
5. Gas composition:

CONSTITUTION	Range by % VOLUME
Methane	85.7 - 93.52
Ethane	2.45 - 6.55
Propane	1.28 - 3.12
Nitrogen	0.53 - 1.21
Carbon-dioxide	0.01 - 0.57
Iso-Butane	0.31 - 0.75
N-Butane	0.4 - 1.14
Iso-Pentane	0.19 - 0.47
N-Pentane	0.17 - 0.38
Hexane	0.34 - 1.16
Gravity	0.6204 -0.6919
Calorific Value(net)	8704.3- 9595.4 Kcal/SCUM

Note : For Operating Principle may please refer Annexure IV enclosed alongwith.

ITEM NO. 20

INSTALLATION & COMMISSIONING, (QTY. – 1AU)

1. Installation & Commissioning:

- a) The party shall provide installation & commissioning of the Remote Ignition System at site i.e. LPG Off-take point Flare pit inside Industrial Area of Oil India Limited, to the full satisfaction of OIL.
 - b) The successful bidder shall complete installation and commissioning of the system within 3 Months (90days) after receipt of the materials at site. The bidder must provide a Gantt chart for installation and commissioning after getting the firm order and they must complete the installation and commissioning job within that time frame.
 - c) The Supplier shall carry out complete installation and commissioning of all supplied instruments.
 - d) The Supplier shall carryout the performance test of equipment at site to demonstrate guaranteed performance of the system.
 - e) The Supplier has to provide the proposed installation diagrams of the system and different instruments for OIL's approval.
- Enclosure of PR No. 1413262 dated 08.04.2015
- f) All tools, tackles and test equipment required for installation and commissioning and carrying out performance tests shall be arranged by the Supplier.
 - g) The Supplier shall arrange boarding & lodging for his engineers and transportation of men and materials to site at his own expense.
 - h) Bidders are required to quote for Installation and Commissioning Charges separately keeping in view the above.

2.Scope of Work:

[A] Scope of OIL:

1. Electrical power up to battery limit (i.e. up to H.E. Panel): 230 VAC, 1 Phase, 50 Hz.
2. Pilot Gas pipe line both ½ inch and 1 inch, 40psi up to battery limit with necessary isolation valve. However gas pressure regulator to step down the pilot gas operating pressure (maximum 10psi) under bidder's scope.
3. Air line for pneumatic operation of instruments if required.
4. Civil work for foundation if any.

[B] Scope of Bidders:

1. Design, Engineering, Fabrication, Supply, Installation and commissioning.
2. BIDDER may inspect the site and obtain all information required for the satisfactory completion of work. Ignorance of site conditions shall not be accepted as basis for any claim for compensation.
3. Companion flange pairs with stud & nuts for pilot gas line (½ inch and 1inch) connection, Regulators, Solenoid valves, Strainers and all other accessories such that the system is functionally and operationally complete in all respect.
4. Oil will provide only 230V AC, 50Hz, power. Any step up or step down AC or DC power required is under bidder's scope.

3. Warranty:

The equipment/materials will be guaranteed for a period of 18 (eighteen) months from the date of receipt of the materials at OIL's depot or 12 (twelve) months from the date of commissioning whichever is earlier. The supplier shall repair or replace any item or equipment found defective in materials or workmanship or performance within the above period free of charge. The warranty is applicable to bought out items also.

4. Inspection:

The items shall be inspected and tested at supplier's/ manufacturer's works/factory by OIL's engineers prior to dispatch. All relevant documents shall be produced at the time of inspection. Three weeks prior notice to be given to OIL for pre-despatch inspection.

5. Delivery:

Delivery will be at Duliajan, Assam and the item should come with proper packing to avoid transit damage.

6. Documentation:

The bidder must provide the following documentation at the time of supply of the main equipment:

- a) Operation and maintenance manuals of each field instruments
- b) GA drawings
- c) Cable schedule and wiring diagram
- d) Hook up drawings
- e) Detailed operation and maintenance manuals of the system

The bidder must submit all As Built drawings as soon as installation and commissioning is over.

7. Training:

The successful bidder shall have to provide onsite training on operation and maintenance of the system to OIL's personals after commissioning of the system.

8. Spares:

The bidders have to submit a list of recommended spare parts along with OEM part nos and price along with bid for maintenance of the system after warranty. However, the price will not be considered for bid evaluation.

TERMS & CONDITIONS:

1. The bidder shall provide technical literature/ catalogue along with the offer for technical scrutiny.
2. The item shall be packed adequately for protection against transit damage and ingress of water.
3. Warranty & Calibration certificates along with Quality Assurance Certificates are to be provided along with the material.
4. Operation and Maintenance manuals must be provided along with the each equipment.
5. Each instrument shall have a SS tag plate attached firmly to it at a visible place indicating the following information's- Tag Number, Manufacturer Name and/or Trademark, Serial No. and Model, Range, Statutory Body Certification No.
6. The bidder must confirm in their offer that authorized service center for the offered item is available in India for maintenance/service support.

Bidders should submit their bids (preferably in tabular form) explicitly mentioning compliance / non compliance to all the NIT terms and conditions of NIT.

Annexure - IV

OPERATING PRINCIPLE

The basic purpose of this RIS is to light up the pilot flame and to monitor the flame continuously which shall be used in Liquefied Petroleum Gas Off-take Take Point open type flare pit. This pilot flame shall be on all the time and shall be capable of burning flare gas upto 4.5 MMSCUM/D whenever there is an operational requirement.

Operation of the Remote Ignition System:

1. The schematic diagram of the Remote Ignition System is as shown in the Fig.1 below.
2. When HE Panel starts solenoid valve (S3) shall be energised.
3. During ignition, both the solenoid valves (S1 & S2) shall be in energized condition and solenoid valve (S3) will be de-energised to generate HV spark. When the HV spark is generated, the same shall be carried away to the burner tip at a distance of 100 meter to light up the pilot flame through the 1 inch line by air pressure. This line shall be used only during ignition.
4. After the pilot flame is established, the flame shall be sensed by Flame sensor and '**Flame ON**' indication shall glow in the panel. After that solenoid valves (S1 & S2) shall be changed to de-energised condition.
5. The ½ inch line shall therefore supply gas for Pilot burner to light up the flame continuously as the solenoid valve (S3) is in de-energized condition.
6. If pilot flame sensing fails, then solenoid valve (S3) will be energised condition and thus discontinue the supply of pilot gas, and the '**Flame Failure**' indication and alarm shall come in the panel.
7. In running condition, all solenoid valves shall be de-energized mode and indicators of '**Power ON**' & '**Flame ON**' of HE panel shall glow.

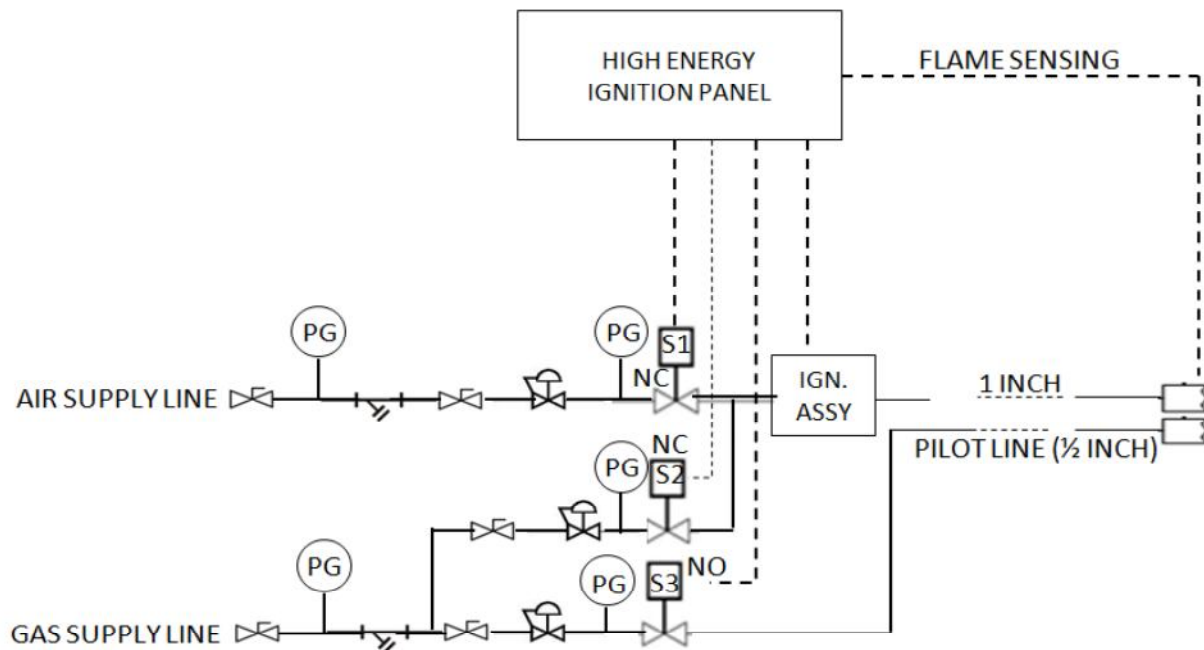

Fig. 1: Schematic Diagram of Remote Ignition System
Legends: S1, S2, S3: Solenoid valves. PG-Pressure gauge.

..... X

Technical Bid Checklist

Annexure-EEE

Tender No.			
Bidder's Name :			
		Compliance by Bidder	
SL. NO.	BEC / TENDER REQUIREMENTS	Indicate 'Confirmed' / 'Not Confirmed' / Not applicable	Indicate Corresponding page ref. of unpriced bid or Comments
1	Bidder to confirm that he has not taken any exception/deviations to the bid document .		
2	Confirm that the product offered strictly conform to the technical specifications.		
3	Confirm that the Offer has been made with Bid Bond / Bank Guarantee / Earnest Money along with the offer (Wherever Applicable) ?		
4	Confirm unconditional validity of the bid for 120 days from the date of opening of techno-commercial bid.		
5	Confirm that the prices offered are firm and / or without any qualifications?		
6	Confirm that all relevant fields in the on-line bidding format been filled in by the bidders for the items quoted by them.		
7	Confirm that the the price bid is in conformity with OIL's online bidding format ?		
8	Confirm that the Bid comply with all the terms & conditions ?		
9	Confirm that the offers and all attached documents are digitally signed using digital signatures issued by an acceptable Certifying Authority (CA) as per Indian IT Act 2000.		
10	CONFIRM THAT YOU HAVE SUBMITTED THE DULY SIGNED INTEGRITY PACT DOCUMENT (Wherever Applicable)		
11	CONFIRM THAT YOU HAVE SHALL SUBMIT PERFORMANCE BANK GUARANTEE AS PER NIT IN THE EVENT OF PLACEMENT OF ORDER ON YOU (Wherever Applicable)		
12	CONFIRM THAT YOU HAVE SUBMITTED DOCUMENTS AS PER GENERAL QUALIFICATION CRITERIA		
13	Confirm that you have submitted Name and Full Address of Issuing Bank including Telephone, Fax Nos and Email id of branch manager where Bid security has been submitted as Bank Guarantee.		

NOTE: Please fill up the greyed cells only.

Response Sheet

Annexure-FFF

Tender No.	
Bidders Name	

Bidders Response Sheet

Sl No.	Description	Remarks
1	Name of Bidder	
2	Whether tender document purchased from OIL's offices.	
3	Place of Despatch	
4	Whether Freight charges have been included in your quoted prices	
5	Whether Insurance charges have been included in your quoted prices	
6	Make of quoted Product	
7	Offered Validity of Bid as per NIT	
8	Delivery Period in weeks from placement of order	
9	Complied to Standard Payment Terms of OIL or not.	
10	Bid Security Submitted (if applicable)	
11	Details of Bid Security Submitted to OIL (if applicable)	
	a) Bid Security Amount (In Rs):	
	b) Bid Security Valid upto:	
12	If Bid security submitted as Bank Guarantee, Name and Full Address of Issuing Bank including Telephone, Fax Nos and Email id of branch manager	
13	Bid Security if Not submitted reasons thereof	
14	Whether you shall submit Performance Security in the event of placement of order on you (if applicable)	
15	Integrity Pact Submitted (if applicable)	
16	Whether submitted documents in support of General Qualification criteria of NIT	
17	If bidder is Small scale unit whether you have quoted your own product	
18	If bidder is Small scale unit whether you are eligible for purchase preference (as per Govt guidelines)	
19	Whether filled up the bank details for online payment as per Annexure GGG	

NOTE: Please fill up the greyed cells only.

**(TO BE FILLED UP BY ALL THE VENDOR IN THEIR OWN LETER HEAD)
(ALL FIELDS ARE MANDATORY)**

Tender No. :.....
Name of Beneficiary :M/s.....
Vendor Code :.....
Address :.....
.....
Phone No. (Land Line) :.....
Mobile No. :.....
E-mail address :.....
Bank Account No. (Minimum
Eleven Digit No.) :.....
Bank Name :.....
Branch :.....
Complete Address of your
Bank :.....
IFSC Code of your Bank
a) RTGS :.....
b) NEFT :.....
PAN :.....
VAT Registration No. :.....
CST Registration No. :.....
Service Tax Registration No. :.....
Provident Fund Registration :.....

I/We confirm and agree that all payments due to me/us from Oil India Limited can be remitted to our above mentioned account directly and we shall not hold Oil India Limited responsible if the amount due from Oil India Limited is remitted to wrong account due to incorrect details furnished by us.

Office Seal

.....
Signature of Vendor

Counter Signed by Banker:
Seal of Bank:

Enclosure: Self attested photocopies of the following documents-

- 1) PAN Card
- 2) VAT Registration Certificate
- 3) Service Tax Registration
- 4) CST Registration
- 5) Provident Registration Certificate
- 6) Cancelled cheque of the bank account mentioned above (in original).
- 7) Bank Statement not older than 15 days on the date of submission.