

Copyright reserved! Without the written agreement of Launch Shanghai Machinery Co., Ltd. (hereinafter called "Launch"), no company or individual is allowed to copy and backup this manual in any form (electronic, mechanical, photocopy, recording or other forms). This manual is specifically designed for the use of Launch product, and our company doesn't undertake any responsibility for various consequences caused as a result of applying it to the guidance of operating other equipment.

In case of the equipment damage or loss due to the accident of the user himself or third party, abuse or misuse of this equipment, unauthorized change and repair of this equipment, or not conforming to the operation and maintenance requirement of Launch, Launch and its branches won't undertake any responsibility for the expenses and expenditures generated.

For the equipment damage or problem caused as a result of using other optional accessories or consumables instead of original Launch product or its recognized product, Launch won't undertake any responsibility.

Official statement: The purpose of other- product-names mentioned in this manual is to describe how to use this equipment. Their registered trademarks still belong to the original companies.

This equipment is for the use of professional technical personnel or maintenance personnel.

Registered Trademark

Launch has registered its trademark in China and several foreign countries, with the symbol of LAUNCH. Other trademarks, service symbol, domain name, icon, and company name of Launch mentioned in this manual belong to the property of Launch and its subsidiary companies. In the countries where Launch's trademark, service symbol, domain name, icon and company name haven't been registered, Launch declares its ownership on such unregistered trademark, service symbol, domain name, icon and company name. The trademarks of other products and company names mentioned in this manual still belong to the originally registered companies. Without prior written agreement of the owner, nobody can use the trademark, service symbol, domain name, icon and company name of Launch and other companies mentioned in this manual. If you have any question, please visit website of Launch: <http://www.cnlaunch.com> or write to Sales Dept. of Launch Shanghai Machinery Co., Ltd. at No. 661 Baian Road, International Automobile City Auxiliary Parts Park, Anting Town, Jiading District, Shanghai City to contact Launch

Please read and understand the manual before operation



Warning

- This manual is an important part of the product. Please read and understand it thoroughly.
- Keep the manual for future use in inspection and maintenance.
- Do not use the product for any other purposes.
- The manufacturer is not responsible for any damage caused by improper use or uses other than the designed purpose.

Precautions

- Only well-trained personnel can operate the lift. Any changes to the components or use for other purpose without the consent of the manufacturer may cause direct or indirect damage to the product.
- Do not expose the lift to extreme temperature or humidity. Keep it away from heating device, faucet, humidifier or furnace.
- Do not install the lift outdoors or expose it to

rain. If it is really necessary to do so, a special order should be made from the manufacturer.

- Keep the lift away from the dust, ammonia, alcohol, thinner and spray adhesive.
- Keep away from the lift when it is in operation.
- Inspection of the lift should be carried out regularly. Do not operate a damaged lift or a lift with broken parts. All the parts are only replaceable with the parts provided by the manufacturer.
- Do not overload the lift. The maximum lifting weight is clearly marked on the nameplate.
- Do not operate the lift when there are personnel in the vehicle.
- Keep the lifting area clear of obstacle, grease, oil, garbage and other substances.
- Use the lifting point recommended by the auto manufacturer. Keep the support in close contact with the vehicle.
- Use appropriate tools and safety protection equipments such as overall and working boots.
- Pay special attention to the safety labels on the control desk.
- Keep hands and other body parts away from the moving parts of a lift in operation.
- Do not remove or override safety protection of the lift.
- Hydraulic oil for the lift is N32 or N46 mechanical oil. Pay attention to the safe data as described in this manual.
- For the sake of technical improvements, Launch (Shanghai) Machinery Co., Ltd reserves the right to change the specifications without prior notice

Contents

1 General Information.....4	3.2 Operational Procedures.....8
1.1 Application.....4	3.3 Safety Precautions.....8
1.2 Features.....4	4 Troubleshooting.....9
1.3 Specifications.....4	5 Maintenance.....10
1.4 Environment Requirements.....4	5.1 Daily Maintenance.....10
2 Structure.....5	5.2 Monthly Maintenance.....10
2.1 Layout.....5	5.3 Biannual Maintenance.....10
2.2 Electrical Diagram.....6	5.4 Maintenance for 3 Years/5000 Operations.....10
2.3 Hydraulic Diagram.....6	6 Storage and Scrapping.....10
2.4 Pneumatic Diagram.....7	6.1 Storage.....10
2.5 Operation Panel.....7	6.2 Scrapping.....10
3 Operation.....8	Data of Grease and Oil.....11
3.1 Preparatory Inspection.....8	List of wear Parts.....12

1 General Information

1.1 Application

This lift is designed for the purpose of lifting light vehicles under 3.0 tons for vehicle test, service and cleaning.

This machine can also be used as a lifting device in production lines, for material transportation and work piece assembly.

1.2 Features

- The lift features advanced design, durability, compact layout.
- The installation of base frames in the pits can save space in the workshop.
- Hydraulic system keeps both platforms level.
- Mechanical protection device throughout the travel distance.
- Automatic height limiting device.
- Automatic lubricating system and oil-less bearings.

1.3 Specifications

Electric specifications:

Motor (Optional): 2.2kw 2850 r/min

Voltage options:

Single-phase/3-phase 110v/220v 60Hz

Single-phase/3-phase 220v/380v 50Hz

Noise

Noise: ≤ 80 dB (A)

Hydraulic System

Max. Working Pressure: 28 MPa, Flow rate: 5-6L/min.

Pneumatic System

Working Pressure: 5 kg/cm²

Max. Lifting Weight (kg) (lb)	3000(6614)
Max. Lifting Height (mm) (")	1750(69)
Lifting Time (sec)	≤ 50
Lowering Time (sec)	≥ 20
Power (kw)	2.2
Number of Platforms	2
Platform Size (mm) (")	1580×520(62.2×20.5)
Overall Weight (kg)(lb)	630(1389)
Synchronization Precision (mm) (")	$\leq 40(1.6)$
Height difference (mm)	$\leq 8(0.3)$

1.4 Environment requirements

Temperature: 0°C ~ +40°C

Relative Humidity: $\leq 80\%$ at 30°C

Transportation/Storage Temperature: -25°C ~ +55°C

Altitude: ≤ 2000 m(78740")

2 Structure

2.1 Layout

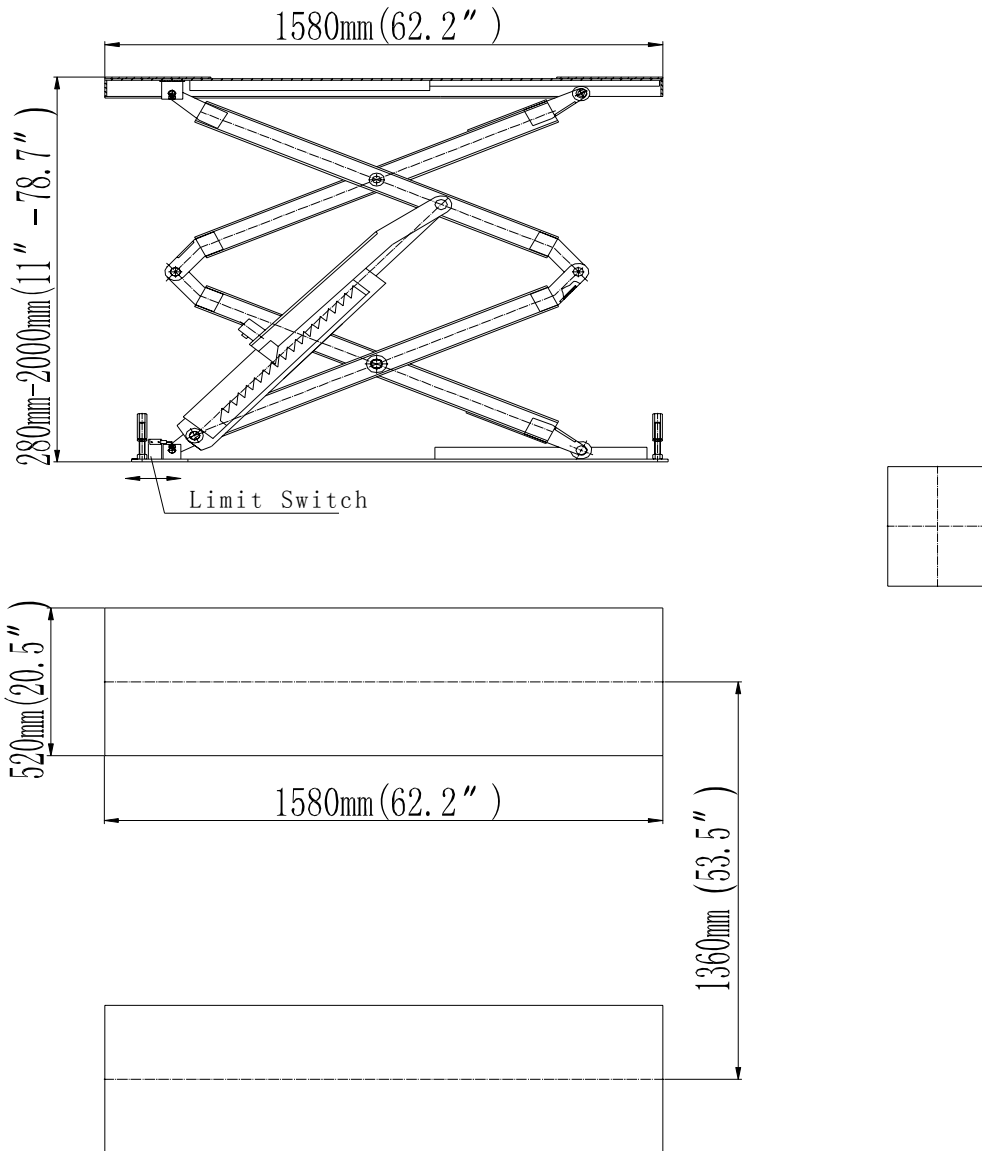

Fig.1

2.2 Electrical Diagram

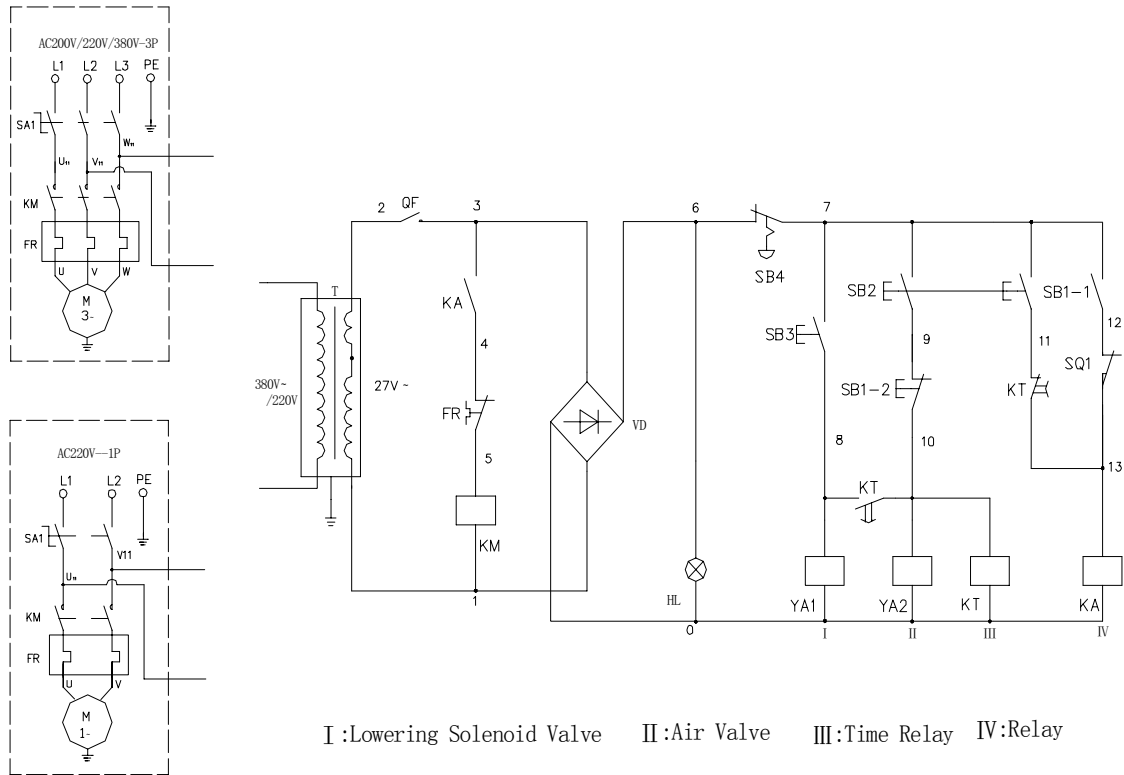

Fig.2

2.3 Hydraulic Diagram

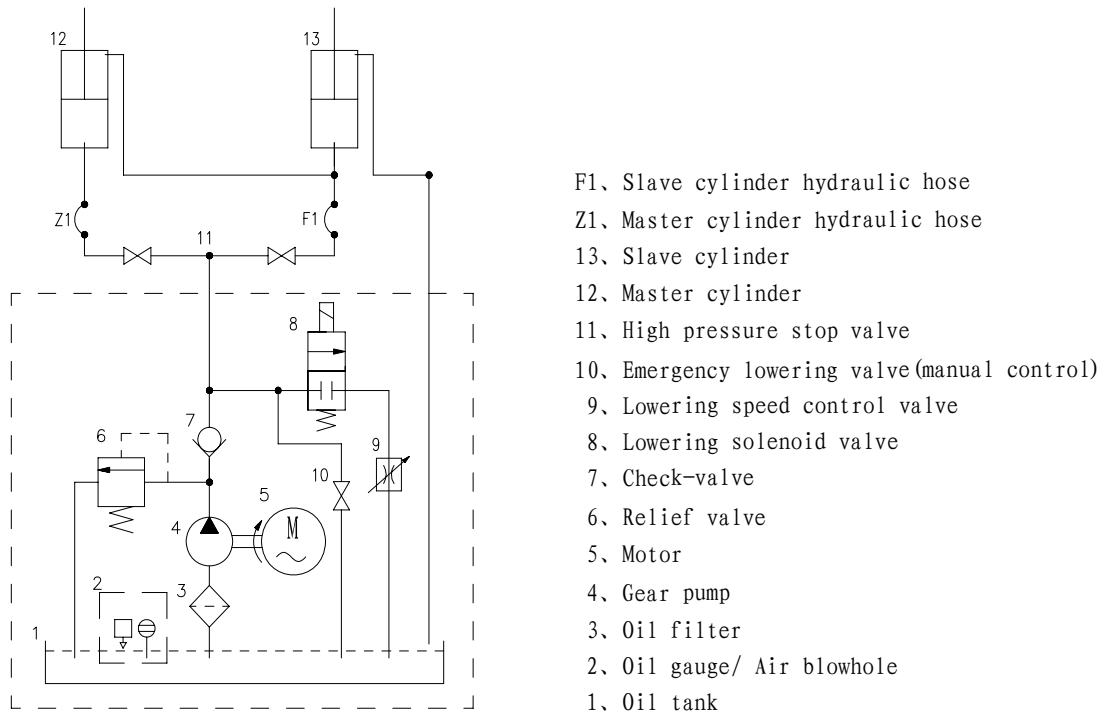
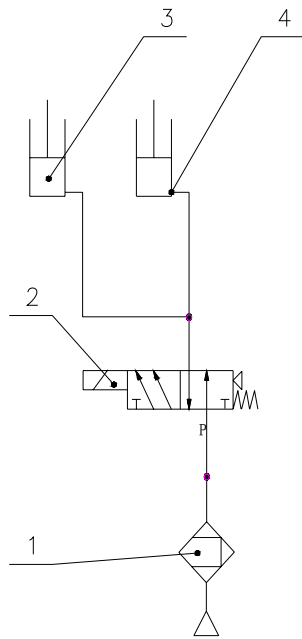

Fig.3

2.4 Pneumatic Diagram



- 1. Air filter and lubricator
- 2. Solenoid air valve
- 3. Air cylinder on master platform
- 4. Air cylinder on slave platform

Fig.4

2.5 Operation Panel

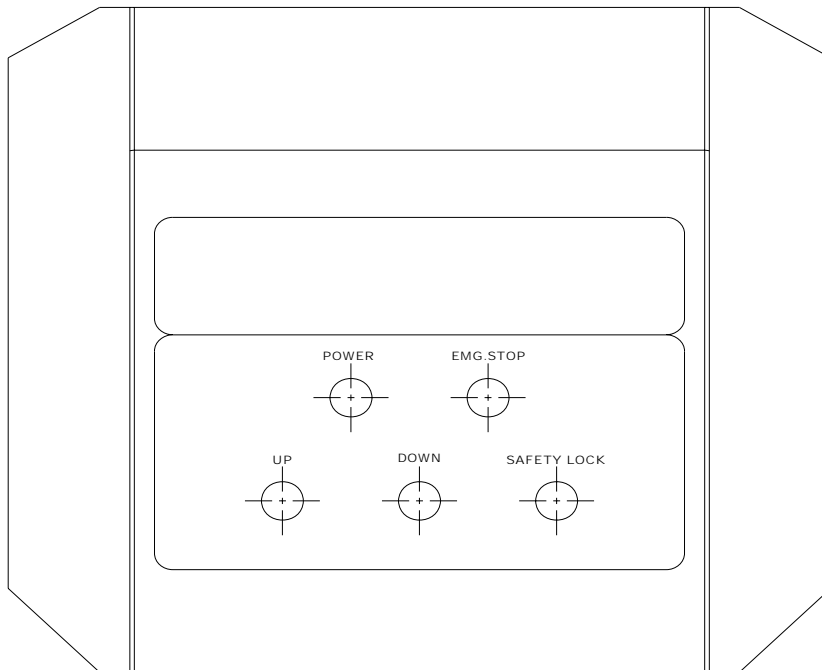

Fig.5

3 Operation

3.1 Preparatory Inspections

- Check for the synchronized and steady movement of the platforms.
- Check the sensibility and reliability of safety ratchet.
- Make sure the platforms would automatically stop when they reach the max lifting height (2000mm/79inches)
- Check for possible leakage in the cylinder, hoses and fittings.
- Check for possible air leakage in the solenoid valve, cylinder, pressure regulator valve and fittings.
- Check for any abnormal action and sound in pump and motor.
- Check if the Emergency Stop button works properly.

3.2 Operational Procedures

- Keep speed below 5km/h when driving on the platforms.
- Stop the vehicle when the platforms are between its front and rear wheels.
- Place rubber pads on the platforms where the lifting points will contact and press UP button to lift the vehicle to 200mm~300mm (9 to 12 inches) from the floor.
- Make sure that the two platforms are leveled and nothing unusual is found.
- Keep pressing UP button until the vehicle rises to the required height.

- Press SAFETY LOCK button to lower the lift and engage the safety ratchet so that the platforms are leveled with one another.
- After the maintenance is done, keep the work area clear and safe before lowering lift.

3.3 Safety Precautions

- The hydraulic relief valves are well-adjusted before leaving factory. The manufacturer will not be responsible for any damage caused by unauthorized adjustment.
- Check the safety lock ratchets are engaged before going about any under-car jobs.
- Place rubber pads on the platforms and spread them for maximal support.
- In case of any leakage in the hydraulic system, fix the problem and refill the oil to the proper level.

Caution: Once the safety ratchets are fully in place, the LOCK button should be released immediately. If the Lock button is pressed for too long, too much oil would flow back from cylinder. In this case, the safety ratchets can not be completely released from locked position within the set time for the platforms to go up when the DOWN button is pressed. This can result in no lowering action, or lowering of only one platform, which may cause the vehicle to fall from the lift. (Please refer to the Working Principles of the lift)

4 Troubleshooting

Symptoms	Reasons	Solutions
The motor does not work.	Thermo relay or circuit breaker actuated Voltage is not correct. Electrical wiring is wrong. Motor is broken.	Reset the thermo relay or circuit breaker Supply power of correct voltage. Fix the wiring. Change motor.
The motor works, but the platforms do not move, or can only go up slowly.	The motor rotates in the wrong direction. Oil level is too low. Height limit switch is stuck or damaged.	Exchange wiring of motor to change direction. Add oil. Repair or replace the height limit switch.
The motor works, but the platforms can not lift the vehicle.	The voltage to the motor is too low. Pressure of relief valve is not right. The lift is overloaded The hydraulic pump is damaged.	Supply motor with correct voltage. Adjust the pressure of relief valve. Check the weight of the vehicle. Replace the hydraulic pump.
The lift is too slow in lowering.	There is foreign substance in the lowering solenoid valve. Lowering speed valve is turned too low.	Clean the lowering solenoid valve. Turn the lowering speed valve up.
The platforms are not synchronized.	There is air in upper chamber of Master Cylinder or Slave Cylinder. The oil supply can not be cut off because of the leakage of stop valve. Leakage in hydraulic system	Air bleeding performance is needed. The air in the master and slave cylinder can be bled after the platform goes up and down several times. Replace stop valve. Replace the seal or the cylinder.
Safety ratchets cannot be separated from serration.	The air pressure regulating valve is closed or too low. The Solenoid air valve is damaged. The LOCK button is pressed for too long time.	Adjust air pressure to 5kg/cm ² Replace the solenoid air valve. Release the LOCK button immediately after the safety ratchets are fully engaged.

5 Maintenance

5.1 Daily Maintenance

- Keep the lift clean. Make sure power is cut off before cleaning the lift.
- Keep the working area clean. Excessive dust in the work area will shorten the lifespan of the lift.
- Before operation, inspect and keep all the safety devices of lift in order. If any problems are found, adjust, maintain or replace the parts in a timely manner.
- Make sure that the pits are kept dry and clean.
- Inspect if there is leakage in the air valve and if it is well-lubricated.

5.2 Monthly Maintenance

- Refasten the anchor bolts.
- Check all the hoses and fittings for possible wearing and leakage. If any leakage is found to be caused by worn sealing parts, replace with

parts meeting the specifications.

- Check if the roller slide is well-lubricated with high-quality #2 lithium lubricant.
- Apply #2 lithium lubricant on a monthly basis.

5.3 Biannual Maintenance

- Check all the moving parts for possible wearing, interference and damage.
- Inspect the lubrication of all the rollers. If the roller is dragged along in lifting or lowering, apply lubricant to the roller shaft.
- At the end of the first six months, clean the hydraulic system and replace the hydraulic oil. Replace the hydraulic oil with N32 hydraulic oil in winter and N46 in summer.

5.4 Maintenance for 3 Years or 5000 Times Operations

- Replace the bushings at all joints.
- Replace all seals
- Replace the rollers.

6 Storage and Scrapping

6.1 Storage

When the lift needs to be stored for a long time:

- Unplug from power socket.
- Lubricate all the parts, including all the contact surface of the rollers.
- Bleed oil from tanks.
- Cover the lift with plastic hood.

6.2 Scrapping

When the lift has exceeded its lifespan and can not be used any more, disconnect it from the electrical supply and dispose of as required by the local regulations.

Hydraulic Oil Data

#2 Lithium Lubricant

Item	Specifications
Conical degree (1/10mm)	278
Dropping point °C	185
Erosion (T2 Copper Plate, 100 °C, 24h)	No Change
Copper Screening (100 °C, 22h) %	4
Evaporation (100 °C, 22h) %	2
Oxidizing Stability (99 °C, 100 h)	0.2
Non-corrosibility (52 °C, 48)	Grade 1
Foreign substance (Microscopic method) / (number/cm ³)	
Above 10µm	Fewer than 5000
Above 25µm	Fewer than 3000
Above 75µm	Fewer than 500
Above 125µm	0
Relative Viscosity (-15 °C, 10s ⁻¹) ,/(Pa s)	< 800
Humidity Loss (38 °C, 1h) (%)	≥8

N32 Mechanic Oil (for winter)

Item	Specifications
Moving Viscosity 40 °C	28.8~35
Pour / °C	≤-15
Flash point / °C	≥175

N46 Mechanical Oil (for summer)

Item	Specifications
Moving Viscosity 40 °C	41.4~50.6
Pour / °C	≤-9
Flash point / °C	≥185

TLT630A Wear Parts

NO	CODE	NAME & SPEC	USE FOR	QTY
1	GB1235-76	O-ring 105x3.1	Master cylinder	2
2	GB1235-76	O-ring 35x3.1	Master and slave cylinder	2
3	GB1235-76	O-ring 95x5.7	Slave cylinder	1
4	GB10708.3-89	Dust proof ring FC45x53x5	Master and slave cylinder	1
5	S55044	Seal-ring 105x89.5x6.3	Master cylinder	1
6	S55044	Seal-ring 95x79.5x6	Slave cylinder	1
7	S55013	Seal-ring GS45x60.5x6	Master cylinder	1
8	GB10708.1-89	Shaft sealing ring GY45x55x7	Master cylinder	1
9	103040157	Seal gasket 14		5
10	103040158	Seal gasket 16		5
11	104130182	Z8 Seal	Air cylinder	2
12	102990070	Air connector APL6-01		2
13	102990071	Air connector APL6-02		2
14	102160380	T air connector APE6		1