



WARTHOG WGR MAGNUM SERIES CONTROLLED ROTATION SEWER NOZZLE USER MANUAL



DESCRIPTION:

The Magnum Series Warthog WGR (hereafter WGR) Controlled Rotation Sewer Nozzle is designed for waterjet cleaning of pipes and sewer lines.

- Jet thrust from the water powers the rotation of the head and pulls the tool through the line.
- The WGR can be provided with either a 1" NPT or 1" BSPP female threaded inlet nut.
- The WGR is capable of working pressures up to 5000 psi and flow rates of 50 to 80 gpm.
- The carbide face seals allow the use of recycled water or fresh water for jetting.
- The nozzle utilizes a rotor and viscous fluid speed control mechanism to provide consistent rotation speed.
- As with all Warthog nozzles, the orifice sizes are selected to best match the desired operating conditions of pressure and flow.
- Hose length and size must be known to correctly determine the proper orifice sizes.
- Contact your distributor or reference www.sewernozzles.com to help in nozzle selection.

⚠ WARNING

Operations with this equipment can be potentially hazardous. Caution must be exercised prior to and during machine and water jet tool use. Please read and follow all of these instructions, in addition to the guidelines in the WJTA Recommended Practices handbook, available online at www.wjta.org. Deviating from safety instructions and recommended practices can lead to severe injury and/or death.

- Always inspect the nozzle for damage prior to operation.
- Do not exceed the maximum operating pressure specified for any component in a system. The immediate work area must be marked off to keep out untrained persons.
- Inspect the equipment for visible signs of deterioration, damage, and improper assembly. Do not operate until repaired. Make sure all threaded connections are tight and free of leaks.
- All operators and persons in close proximity must wear personal protective equipment, including approved protection for body, hands, feet, face, ears, eyes, and air passages. Please refer to the WJTA Recommended Practices, Section 6.
- Inspect the high pressure hose for damage. Only high quality hoses intended for waterblast applications should be used.



NOTE: A 15-25 foot long section of leader hose of a different color than the jetter hose is recommended to indicate how close the tool is to exiting the pipe.

Flush the jetter hose prior to installing the nozzle to remove debris. Install the hose guard or Tiger Tail. If the WGR is being used in pipe diameters less than 10 inches it can be attached directly to the hose end. If being used in larger pipes a straight rigid pipe or centralizer must be placed behind the tool such that the rigid length is greater than the pipe diameter to ensure the tool cannot turn around in the pipe.

Risk of serious injury or death: Do not attempt to clean a manhole with the WGR hanging by the hose. The tool can turn around and strike the Operator. Specific accessories are offered and are required to safely clean manholes.

To clean lines, position the WGR and Tiger Tail so it can enter the pipe to be cleaned. The recommended cleaning direction is upstream from the manhole.

Slowly bring the pump up to pressure, making certain that the WGR begins to pull its way into the pipe in the proper direction; allow it to advance a few feet and note the location of the leader hose or other hose marker being used. Once the pump is up to operating pressure, feed out the reel at a reasonable rate to allow the jets time to clean the pipe.

If roots are present, feeding at a slower rate will improve the cleaning results. Depending on the amount of debris in the pipe, it may be necessary to occasionally pull the WGR back toward the manhole to prevent buildup of debris behind the tool.

When finished cleaning, withdraw the tool back to its initial starting point noted by the location of the leader or hose marker.

Shut down and secure the pump before removing the WGR from the line.

After the job has been completed, remove the WGR from the hose and blow out the water with compressed air to prolong the life of the internal components.

TROUBLESHOOTING

Head Will Not Rotate: Check to see if any jets, or inserts, are plugged. Even if a jet is only partially blocked it can keep the head from rotating. Jets must be removed from the head to be properly cleaned. Poking the material plugging the jet back into the head will not fix the problem because it will re-plug the jet once water starts flowing. If the jets are all clear, wash the nozzle off with water to remove any debris or grit between the head, body and shaft. Then try rotating head by hand. It should feel free with a slight amount of smooth resistance. If it feels rough, gritty, or hard to turn, the tool needs to be repaired. It may need new bearings and shaft seals or high pressure seals. It is possible the tool needs viscous fluid added or changed, but if viscous fluid is confirmed to be present, a rebuild should be considered.

Head Spins Too Fast: If the nozzle is spinning significantly faster than normal, or if the nozzle starts to sound different (like a jet engine or a turbo charger) the nozzle may be low on viscous fluid, or the viscous fluid may be contaminated. In this case, add or change the fluid as appropriate. Continued operation in this state can mechanically damage the tool and a rebuild may be required to replace the faulty shaft seals.

High Pressure Water Seals Leak: The WGR's seal design uses a slight amount of water for lubrication. At full pressure it should not leak more than a few drops with a new set of seals. The high pressure seals may need to be replaced if you are not able to get to full pressure or when a continuous spray comes from under the WGR 020 Back Plate.

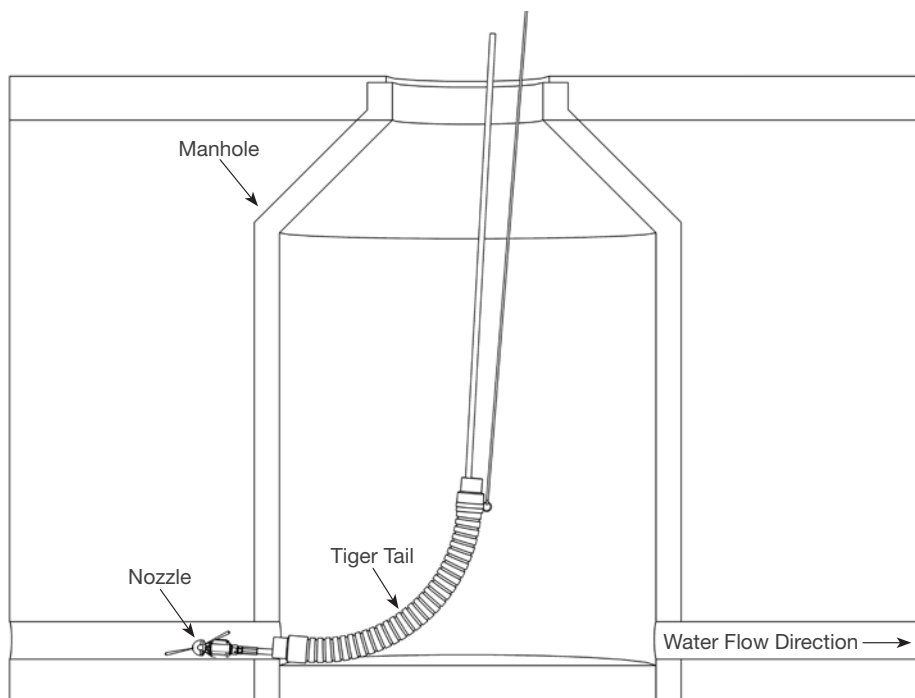

Figure 1. Proper Nozzle Setup

HEAD REMOVAL/REPLACEMENT

LIST OF TOOLS:

- Bench Vice (recommended)
- Arbor Press (recommended)
- Smooth Jaw Adjustable Wrench (such as Crescent® C718 Automotive Wrench)
- Large Adjustable Wrench (such as a 12" Crescent® Wrench)
- Medium size flat-head screw driver
- Pick
- Bearing Splitter
- 3/8 Drive Ratchet with 3" Extension
- WGR 612 Tool Kit
- WGR 180 T-25 L-Wrench
- WGR 181 Removal Press Tube
- WGR 182 Installation Press Tube
- WGR 183 Hex Tool
- WGR 184 HP Seal Press
- WGR 186 HP Seal Puller

LIST OF MATERIALS:

- Clean lint free rags or blue shop towels
- Anti-Seize - StoneAge PN (GP 043 Blue Goop)
- Lithium Soap Grease – StoneAge PN (GP 048 Grease)
- Blue Loctite® 242
- Isopropyl Alcohol

HEAD REMOVAL/REPLACEMENT

*****Product training and proper tools are required to service this nozzle. If you are uncomfortable performing the service, bring the nozzle to your authorized dealer.***

The use of a bench vice and an arbor press is highly helpful. Take care throughout the entire procedure to keep the internals clean and free from grit, lint, and contamination. Failure to do so could result in premature failure after service.

The WGR head is easily removed. Different heads can be configured to match specific jobs. Changing heads is a quick way to get optimal performance for every job type - from flushing lines to removing grease and roots. The shaft and head utilize an O-Ring and straight thread connection, eliminating the need for Teflon Tape and decreasing the change time.

Remove the head. Insert the provided L-Wench (WGR 180) into the hole through the Front Nut (WGR 004) then rotate the Head (WGR 040-R31-???) until the L-Wrench slides all the way through and locks the Shaft (WGR 101) from rotating. Use one wrench on the Front Nut and another wrench on the Head to remove the Head. DO NOT loosen the Head using the Centralizer Fins (WGR 081) or Body (WGR 003) as tool damage may occur.

Replace the Head. Before reinstalling the head, make sure the threads on the shaft and in the head are free from grit, debris, and old Loctite®. Make sure the O-Ring on the shaft is clean and in good condition. Apply Blue Loctite® 242 to the Shaft threads.



Head and Fin Removal

The Centralizer Fins are replaceable without opening the nozzle. Specific fin sizes are available to help optimize cleaning in larger diameter pipes. Keeping the nozzle close to the center of the pipe will increase the effectiveness of the water jets in cleaning the entire pipe.

Fin Removal and Replacement. Remove the six Screws (WGR 030) at the rear of the tool using the provided L-Wrench (WGR 180). The Back Plate (WGR 020) and Fins (WGR 081) can now be removed. Pull the fins rearward and outward. When reinstalling new fins, make sure the front of the groove is free from debris. Replace the Back Plate, apply Blue Loctite® 242 to the Screws, and then tighten the Screws evenly in a star pattern. Tighten Screws to 20 in-lb.

SPEED CONTROL FLUID CHANGE

The speed control fluid changing is made easy with the WGR and disassembly of the tool is not required. This means there is less chance for contamination and longer overall tool life. Fluid changes should only be performed by qualified persons.

NOTE: Improper fluid change maintenance can result in reduced bearing or shaft seal life. **DO NOT PRESSURIZE THE WGR BODY** by forcing new fluid in too fast. The fluid is thick and only very light pressure should be applied to the syringe. Excess pressure will force fluid past the inner shaft seals and into the bearings. Use extreme care when performing this procedure.

The WGR is designed for maximum viscous fluid life and frequent fluid changes should not be required. A fluid change should be performed when replacing bearings and shaft seals.

Fluid Replacement

Fill the Syringe (BC 410) with new Viscous Fluid (BJ 048-M). Position the tool at an angle with one Port Screw (BJ 026) at the highest point and the other Port Screw at the lowest point (preferably mounted in a vise). Clean around, then remove the upper Port Screw from the body. Screw the syringe into the upper port, then remove the lower Port Screw. Using the assistance of gravity, gently ease the new fluid into the Body (WGR 003) while letting the old fluid flow out the opposite hole. Rotate the Head while flushing. ***DO NOT PRESSURIZE THE CHAMBER** by aggressively forcing in fluid.* The fluid is thick and some time is required to complete the flush. Reinstall the exit Port Screw, then remove the Syringe and install the inlet Port Screw.

This flushing procedure is only recommended for replacing the fluid with the same fluid. Not all of the fluid will be replaced using this procedure, therefore full disassembly and cleaning of the tool is recommended when changing to a different speed, or viscosity of fluid.

Tech Tip: The rotation speed of the head can be fine tuned with three different viscous fluid choices to optimize performance for specific applications (Slow Fluid: BJ 048-S, Medium Fluid: BJ 048-M and Fast Fluid: BJ 048-F). The medium viscosity fluid is recommended by StoneAge for maximized performance and minimized maintenance. Please contact your Dealer or StoneAge Customer Service to select the right fluid for your application.

DISASSEMBLY

- 1. Remove the Head (WGR 040-R31-???)**. Insert the provided L-Wrench (WGR 180 T-25 Torx Key) in through the hole in the Front Nut (WGR 004) in order to lock the shaft. Rotating the Head relative to the tool may be required to align the through hole and the shaft. Completely insert the L-Wrench. Use a wrench on the Front Nut and a wrench or a vice on the Head to remove the Head.
- 2. Remove the Fins (WGR 081 or WGR 082)**. Remove the six Screws (WGR 030) which attach the Back Plate (WGR 020). Once the Back Plate is off the Fins can then be removed.
- 3. Remove the Inlet Nut (WGR 102) from the Body (WGR 003)**. Use care to not ovalize Body or Inlet Nut. The use of a bench vice is recommended.
- 4. Remove forward most Port Screw (BJ 026)**.

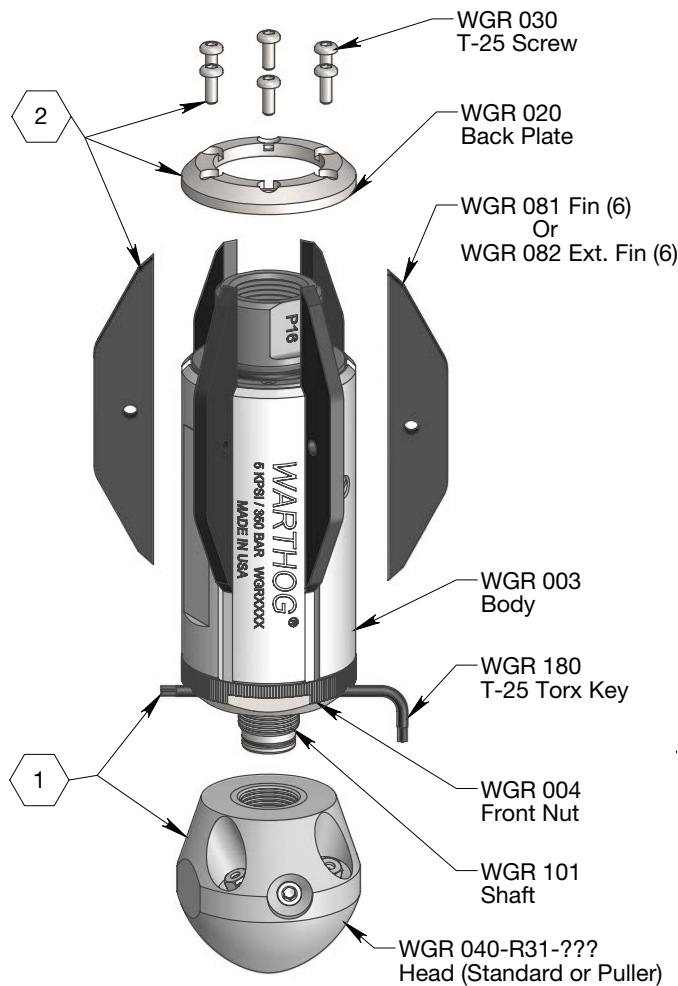

- 5. Remove the Shaft (WGR 101)**. The Shaft presses out rearward, toward the Inlet Nut (WGR 102). Fluid may bleed out of the Port Screw hole during removal. The front Bearing (WGR 007) is pressed into the Body (WGR 003) and should remain in place. The rear Bearing is pressed onto the shaft and should slide out with the Shaft, along with the Seal Spacer (WGR 011) and inner Shaft Seal (WGR 010) when the Shaft is removed.
- 6. Remove the Front Nut (WGR 004) from the Body (WGR 003)**. Use care to not ovalize Body. The use of a bench vice is recommended.

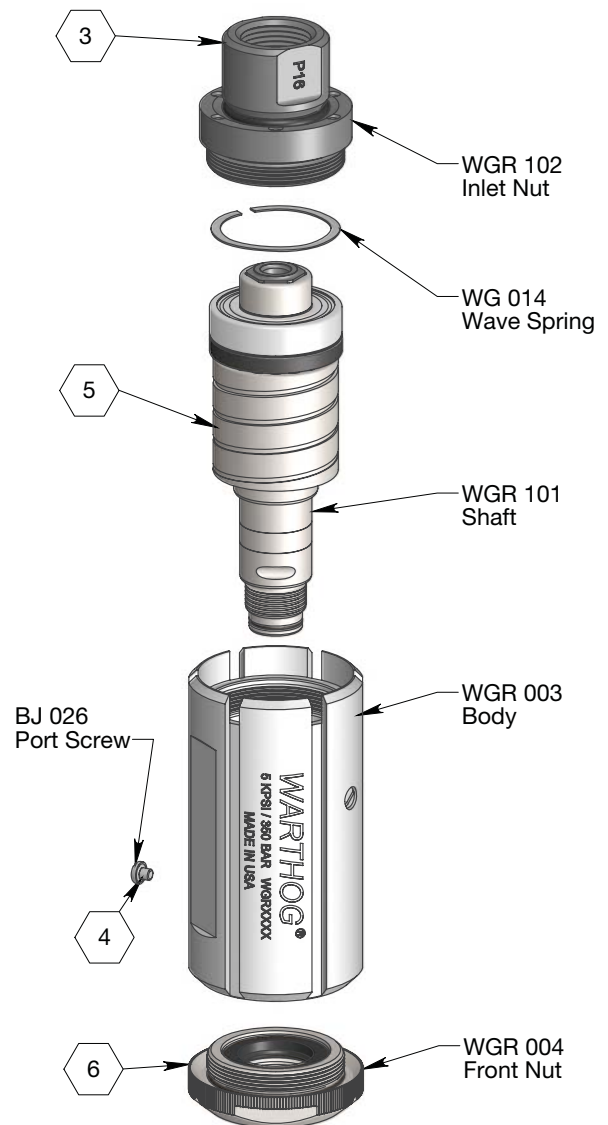

7. Press the front Bearing (WGR 007) out of the Body

(WGR 003). Use the Removal Tube (WGR 181) seated against the inside of the Shaft Seal (WGR 010) to press the Shaft Seal, Seal Spacer (WGR 011) and Bearing forward out of the Body (WGR 003), toward the Head.

8. Remove the Shaft Seal (WGR 006) from the Front Nut

(WGR 004). Use care not to scratch or damage the seal bore of the Front Nut.

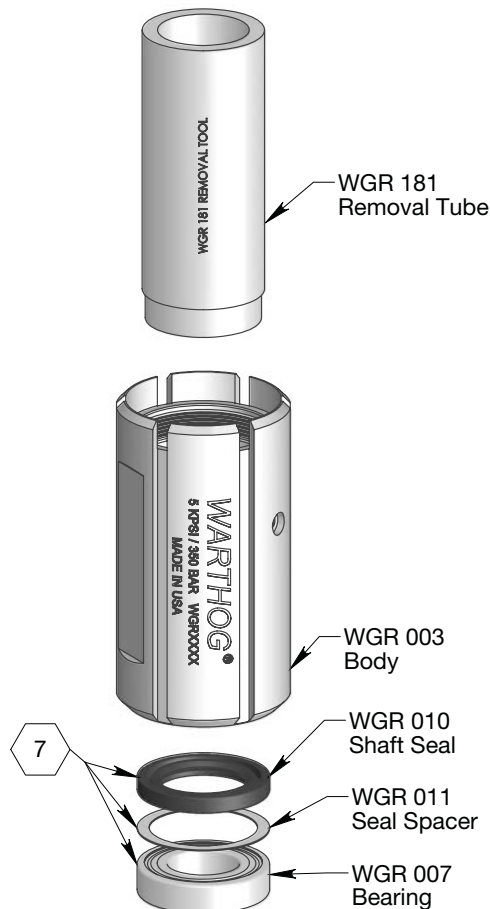

9. Remove the Shaft HP Seal (WGR 058-M90). Squeeze the HP Seal Puller (WGR 186) together and insert it into the bore of the Shaft HP Seal, then release. The HP Seal Puller should hook the bottom edge of the Shaft HP Seal; pull upward in a circular pattern to work the Shaft HP Seal out of the Shaft (WGR 101). Remove the Wave Spring (WGR 052). *Removing the Shaft HP Seal is required to prevent it from being damaged while removing the Bearing (WGR 007) in the next step.* Inspect the polished faces, if damaged, replace HP Seal set (WGR 058-M90 and WGR 059-M90) together.

10. Remove O-Rings from the Shaft (WGR 101). Remove TR200 121 and WS 210. Do not scratch the glands in the shaft otherwise leakage may occur.

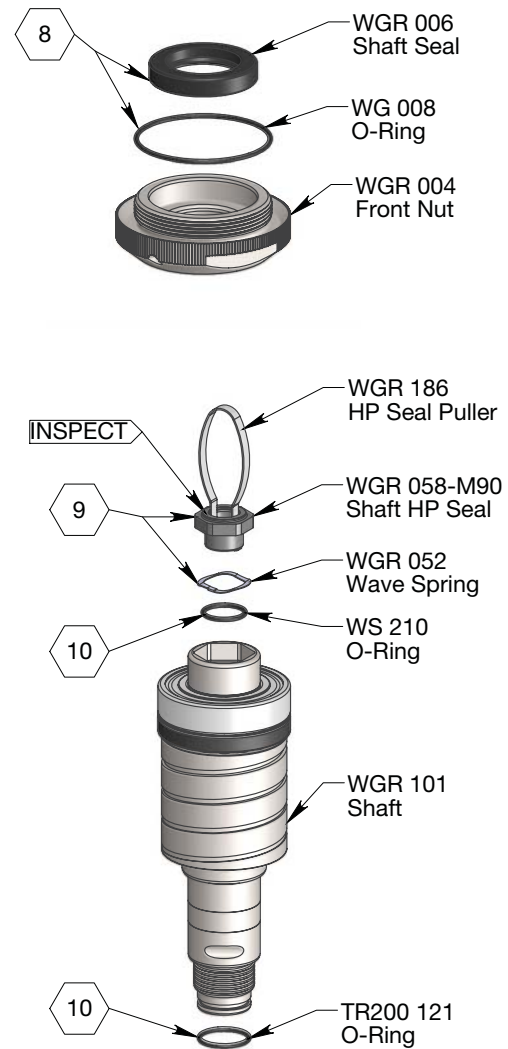

DISASSEMBLY

11. Remove the Rear Bearing (WGR 007). Evenly seat a bearing puller under the Rear Bearing then press on the end of the Shaft (WGR 101) to remove Bearing. Use care to not catch or bend the Seal Spacer (WGR 011). The Seal Spacer and Shaft Seal (WGR 010) will then slip off the shaft.

12. Inspect the Shaft (WGR 101). Inspect for grooving where the four shaft seals ride. Inspect where the bearings ride for signs of the bearings slipping or scratches which extend into the area where the seals operate. Inspect the front shaft lock grooves for interfering deformation. Remove burrs or high spots by grinding or filing. If any place is severely damaged or worn, the shaft may need to be replaced.

13. Remove the Nut HP Seal (WGR 058-M90). Squeeze the HP Seal Puller (WGR 186) together and insert it into the bore of the Nut HP Seal, then release. The HP Seal Puller should hook the bottom edge of the Nut HP Seal; pull upward in a circular pattern to work the Nut HP Seal out of the Inlet Nut (WGR 102). Remove the Wave Spring (WGR 052). Inspect the polished faces, if damaged, replace HP Seal set (WGR 058-M90 and WGR 059-M90) together.

14. Remove the Shaft Seal (WGR 006) from the Inlet Nut (WGR 102). Use care to not scratch or damage the seal bore of the Inlet Nut.

15. Remove O-Rings from the Inlet Nut (WGR 102). Remove WGR 076, WG 008 and WS 210. Do not scratch the glands in the Inlet Nut otherwise leakage may occur.

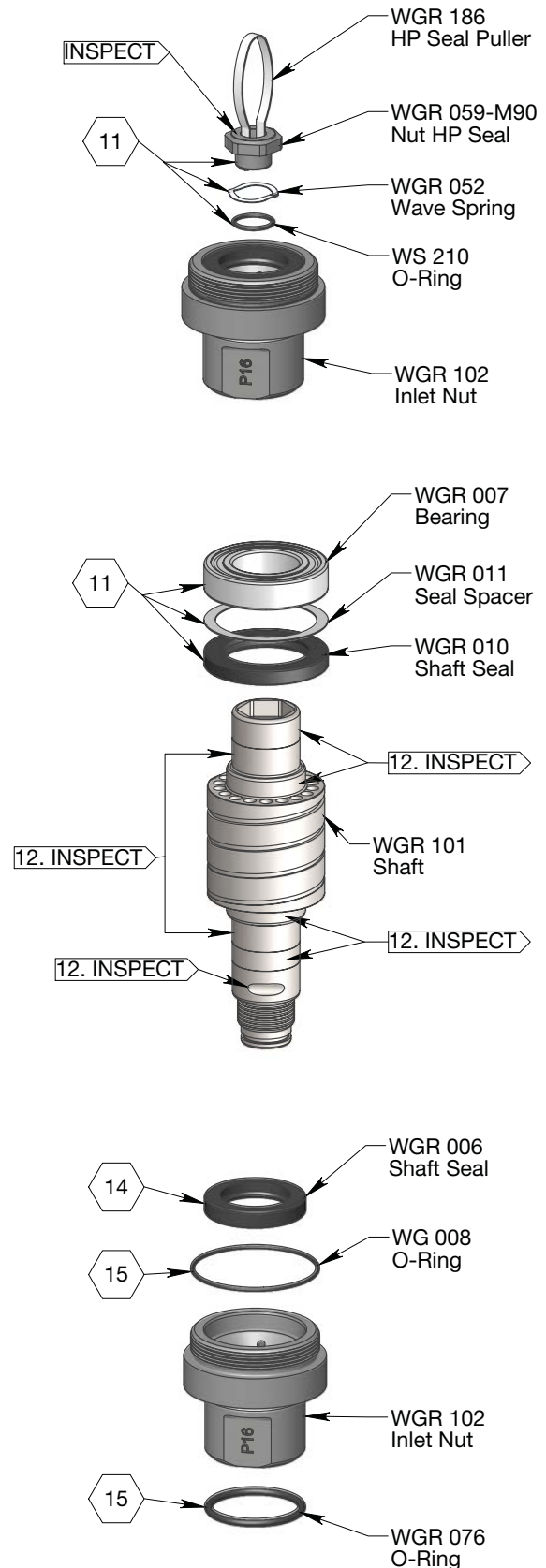

ASSEMBLY

1. **Assemble the O-Rings into the Inlet Nut (WGR 102).**
The O-Ring (WS 210) is installed into the bore for the Nut HP Seal. Apply grease after assembly. The O-Ring (WG 008) seats at the base of the threads. The O-Ring (WGR 076) covers the weep holes.
2. **Install the Shaft Seal (WGR 006).** Install with the lip inward, the lip spring should face into the Inlet Nut. Generously coat the ID lip of the Shaft Seal with grease.
3. **Install the Nut HP Seal (WGR 059-M90).** First place the Wave Spring (WGR 052) into the Inlet Nut (WGR 102). Apply a light coating of grease to the stem of the Nut HP Seal. Using the HP Seal Press (WGR 184) gently press the Nut HP Seal into the Inlet Nut. Rocking the Nut HP Seal in a small circular pattern while applying light pressure may aid in installation. *Pressing too hard will damage or chip the seal. Always use the Seal Install Tool to avoid damage to the polished face.* The Nut HP Seal should compress freely into the Inlet Nut and spring return. Clean the polished face with isopropyl alcohol. The polished face needs to be clean and free from lint, grease and oils.
4. **Apply anti-seize to the threads of the Inlet Nut (WGR 102).** StoneAge recommends Blue Goop® (GP 043).
5. **Assemble the O-Ring onto the Front Nut (WGR 004).**
The O-Ring (WG 008) seats at the base of the threads.
6. **Install the Shaft Seal (WGR 006).** Install with the lip inward, the lip spring should face into the Front Nut. Generously coat the ID lip of the Shaft Seal with grease.
7. **Apply anti-seize to the threads of the Front Nut (WGR 004).** StoneAge recommends Blue Goop® (GP 043).

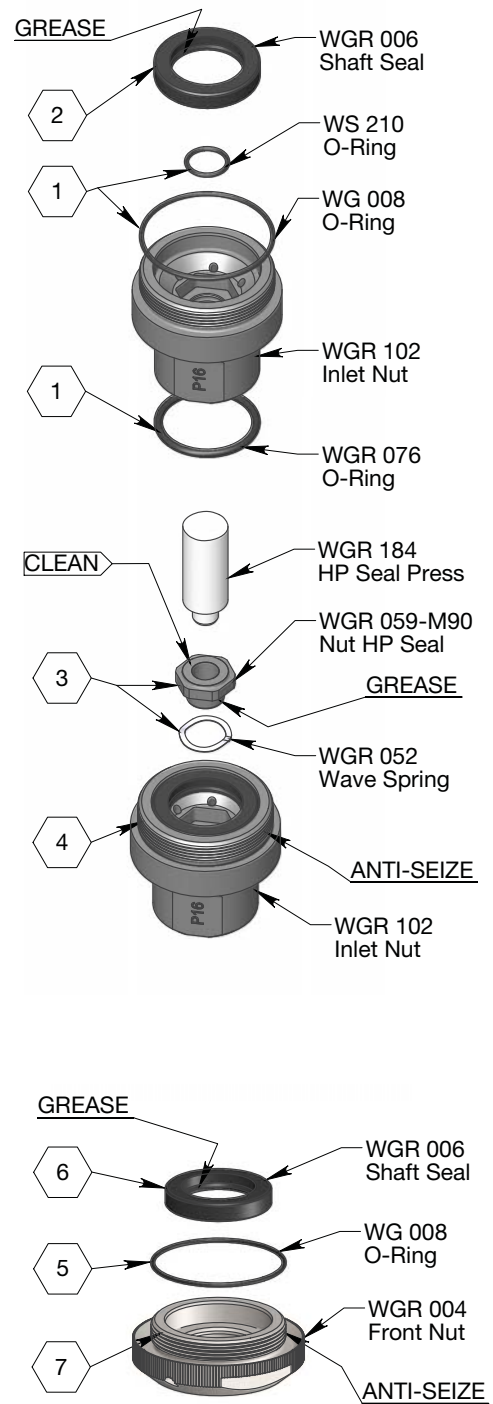

ASSEMBLY

8. **Install the front Shaft Seal (WGR 010).** Use the Install Tube (WGR 182) to install the Shaft Seal into the Body (WGR 003). Install with the lip inward, the lip spring should face in toward the center of the Body. Lightly coat the ID lip with grease.
9. **Install the front Seal Spacer (WGR 011).** Generously coat the Seal Spacer with grease and then drop into the Body.
10. **Install the front Bearing (WGR 007).** Coat the ID and OD of the Bearing with grease, then press into the Body using the Installation Press Tube (WGR 182). Use care to press the Bearing in straight.
11. **Install the Port Screws (BJ 026).**
12. **Install the assembled Front Nut (WGR 004).** Apply anti-seize to the threads. Install the Front Nut tightly. Torque to 115-135 ft-lbs.

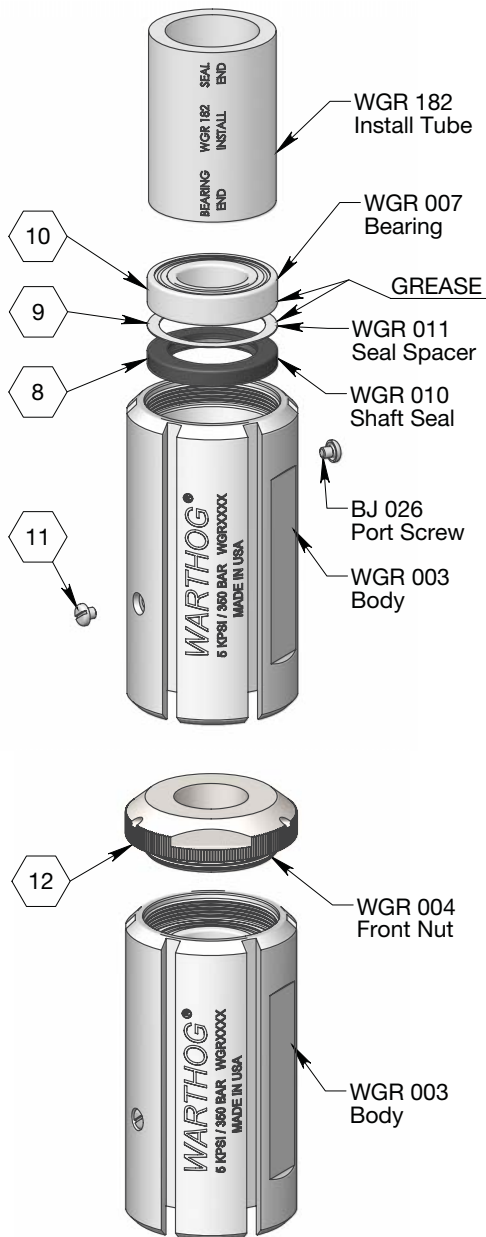

13. **Install the Shaft (WGR 101).** Lightly coat the Shaft with grease where the Shaft Seals and Bearings ride. Gently insert the Shaft into the Body (WGR 003) then push the Shaft into place by hand. The shoulder on the Shaft should stick out slightly from the Front Nut.
14. **Fill with Fluid (BJ 048-M).** Fill the Body with fluid to the bottom of the chamfer of the shoulder on the Shaft.

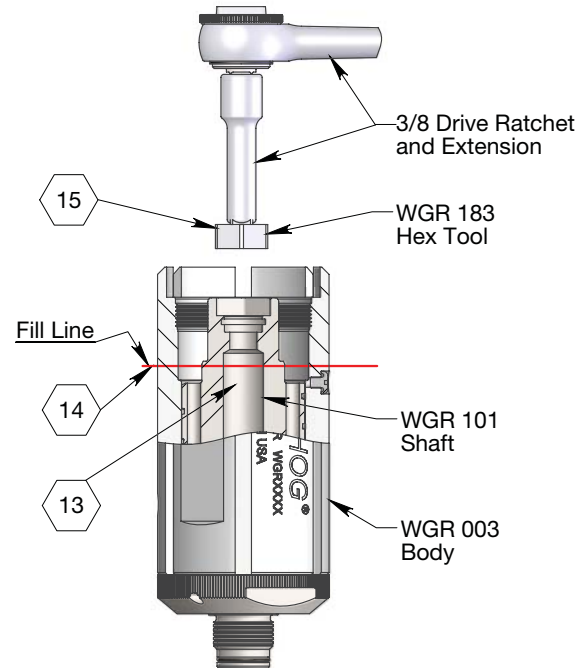

15. **Spin the Shaft (WGR 101) to bleed the Fluid (BJ 048-M).** Attach the Hex Tool (WGR 183) to a 3/8" drive ratchet with a 3" extension and insert it into the internal hex in the end of the Shaft. Spin the Shaft slowly in a CCW direction to work out all the air bubbles from the system.

16. Install the rear Shaft Seal (WGR 010). Lightly coat the ID lip of the Shaft Seal with grease. In one sequence of motions: remove the rear Port Screw (BJ 026) to allow extra fluid to escape, then using the narrow end of the Install Tube (WGR 182) press the Shaft Seal into the Body (WGR 003), then reinstall the Port Screw. Install the Shaft Seal with the lip inward, the lip spring should face toward the center of the Body. Use care to press the Shaft Seal in straight, if any fluid ends up above the Shaft Seal, wipe clean away with a clean towel. *If the fluid chamber is pressurized for any reason, the pressure will force the fluid past the inner shaft seals and into the bearings causing premature bearing failure.*

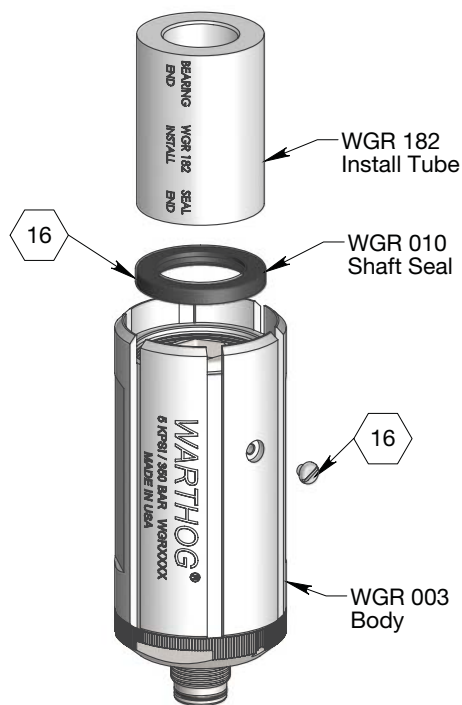

17. Install the rear Seal Spacer (WGR 011). Coat the Seal Spacer with grease then drop into the Body (WGR 003).

18. Install the rear Bearing (WGR 007). Generously coat the ID and OD of the Bearing with grease, then press into the Body using the Installation Press Tube (WGR 182). Use care to press the Bearing in straight.

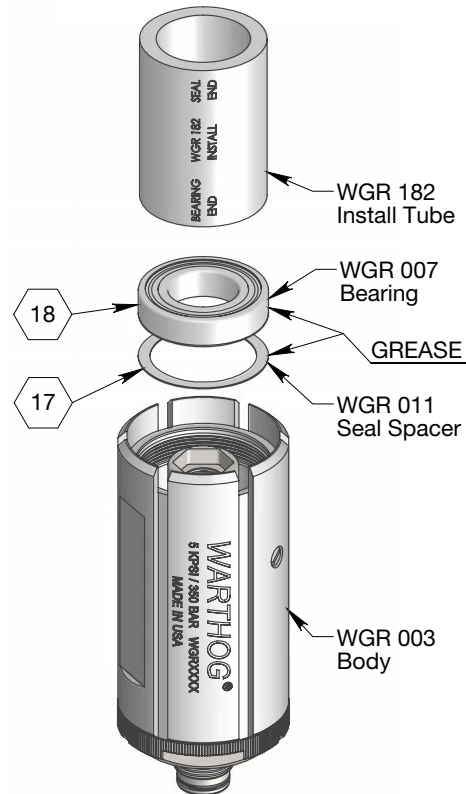

19. Assemble the O-Rings into the Shaft (WGR 101). The O-Ring (WS 210) is installed into the bore for the Shaft HP Seal. The O-Ring (TR200 121) seats in the gland before the start of the threads. Grease both O-Rings after assembly.

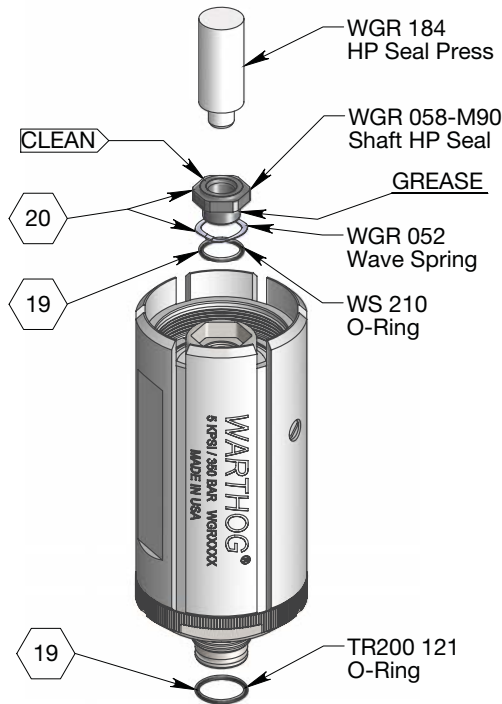

20. Install the Shaft HP Seal (WGR 058-M90). First place the Wave Spring (WGR 052) into the Shaft (WGR 101). Apply a light coating of grease to the stem of the Shaft HP Seal. Using the HP Seal Press (WGR 184) gently press the Shaft HP Seal into the Shaft. Rocking the Shaft HP Seal in a small circular pattern while apply light pressure may aid in installation. *Pressing too hard will damage or chip the seal. Always use the Seal Install Tool to avoid damage to the polished face.* The Shaft HP Seal should compress freely into the Shaft and spring return. Clean the polished face with isopropyl alcohol. The polished face needs to be clean and free from lint, grease and oils.

21. Install the Wave Spring (WG 014). Generously coat the Wave Spring with grease. Drop into the Body on top of the Bearing.

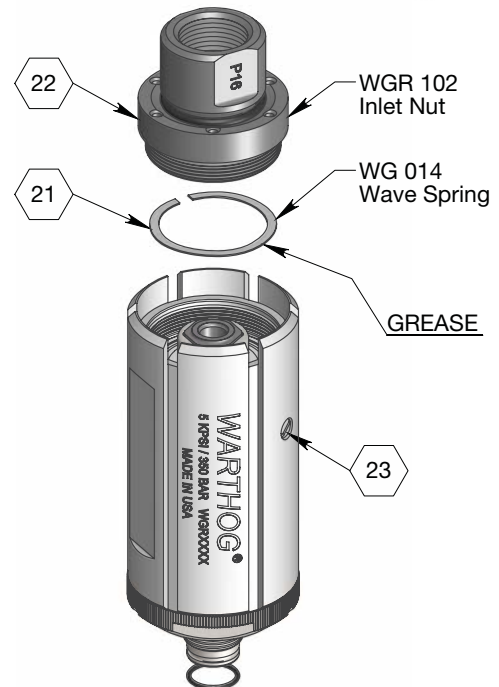

22. Install the assembled Inlet Nut (WGR 102). Apply anti-seize on the threads if not already done. Install the Inlet Nut tightly. (A torque of 115-135 ft-lb. is recommended)

23. Remove the Port Screw (BJ 026) to relieve any internal pressure. Hold the tool at an angle so one of the ports is the highest position, remove the Port Screw to relieve any pressure built up from installing the Inlet Nut (WGR 102) then reinstall the Port Screw.

24. Install the Head (WGR 040-R31-???). Clean the threads of the Shaft, then apply Blue Loctite® 242 to threads. Install the Head tightly. (A torque of 50 ft-lb. is recommended).

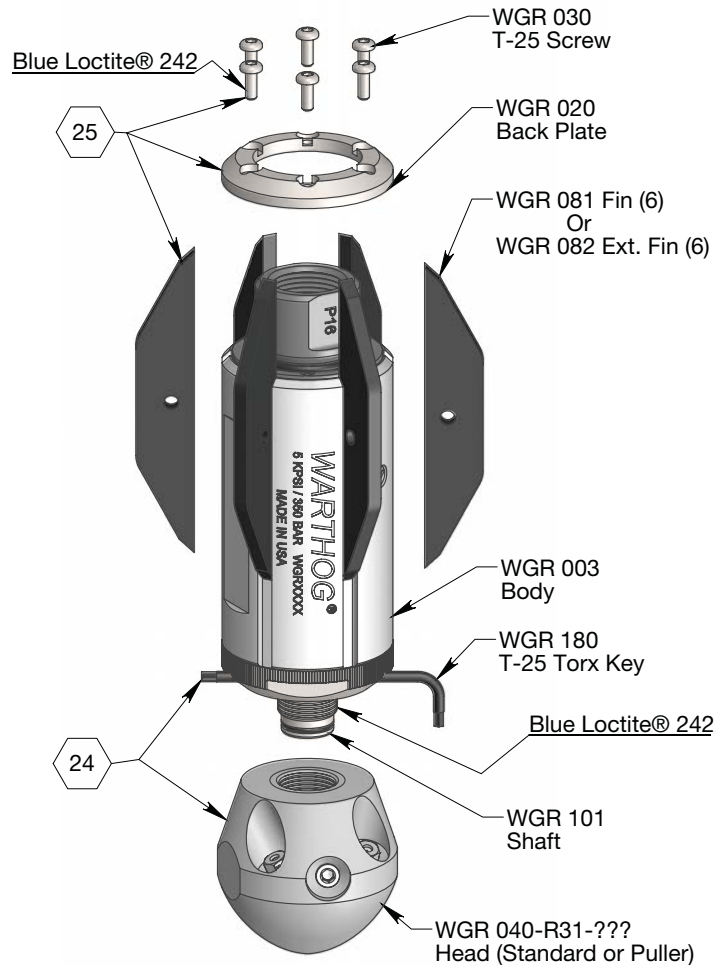

25. Install the Fins (WGR 081 or WGR 082). Place the Fins into the slots in the Body (WGR 003); a rubber band may be helpful in holding them in place until installed. Install the Back Plate (WGR 020). Clean the threads of the six Screws (WGR 030) then apply Blue Loctite® 242 to the Screws. Evenly tighten the Screws in a star pattern until they are all tight. (A torque to 20 in-lb. is recommended).

PART NAMES/NUMBERS - SERVICE KITS

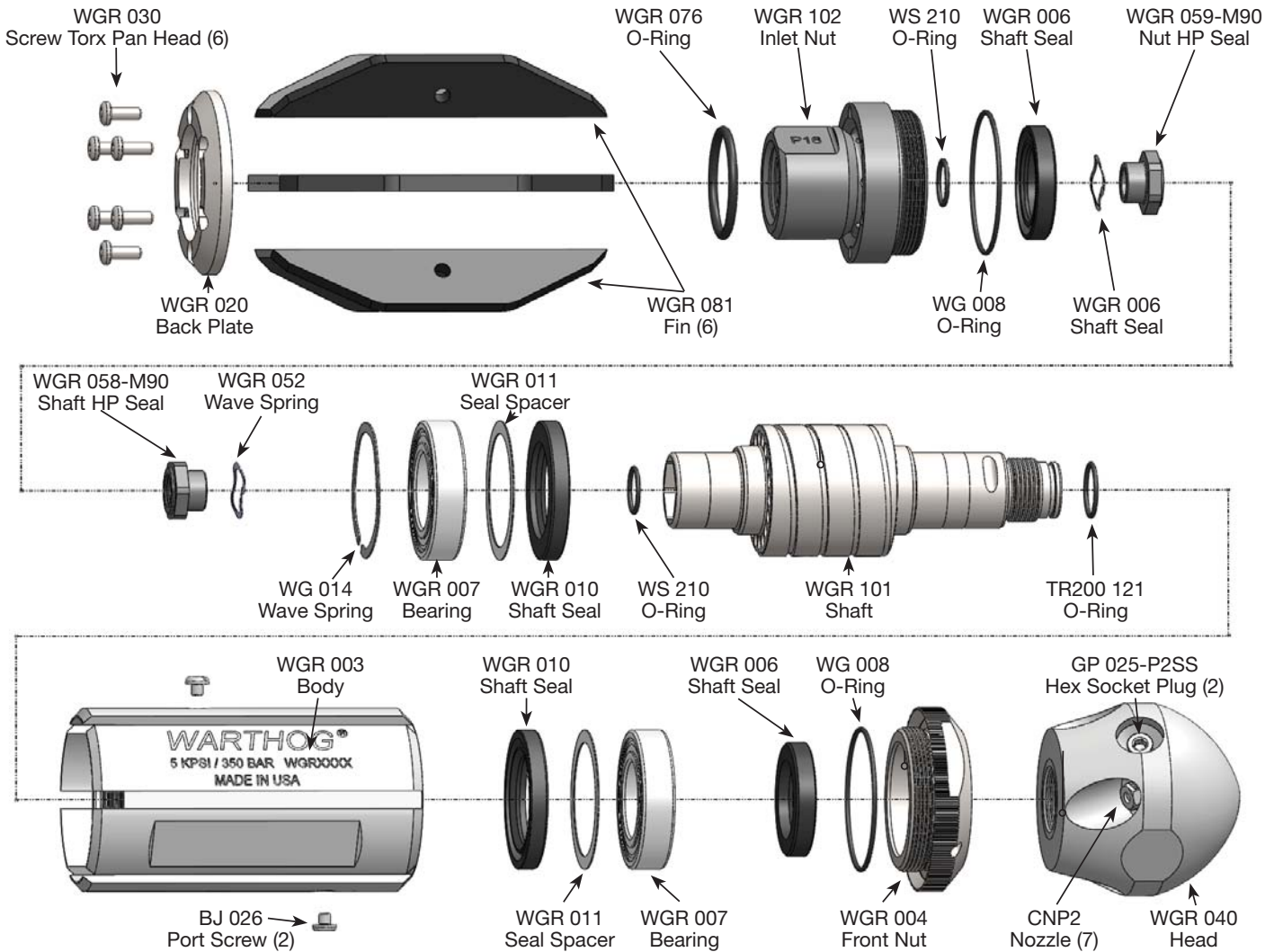

MAINTENANCE & OVERHAUL KITS

WGR 600 - SERVICE KIT

- 1 BJ 026 Port Screw
- 1 BJ 048-M Visc Fluid, Medium, 6oz
- 1 BJ 062-S Antiseize, 2g
- 1 TR200 121 Head - Shaft O-Ring
- 1 WG 008 Nut O-Rin
- 2 WGR 006 Shaft Seal - Outer
- 2 WGR 007 Bearing
- 2 WGR 010 Shaft Seal - Inner
- 2 WGR 011 Seal Spacer
- 6 WGR 030 Torx Screws

WGR 601 - FLUID SERVICE KIT

- 1 BC 410 Syringe
- 2 BJ 026 Port Screw
- 1 BJ 048-M Visc Fluid, Medium, 6oz

WGR 602 - HP SEAL KIT

- 1 BJ 062-S Antiseize, 2g
- 2 WGR 052 HP Seal Wave Spring
- 1 WGR 058-M90 HP Seal - Shaft
- 1 WGR 059-M90 HP Seal - Nut
- 2 WS 210 HP Seal O-Ring

WGR 610 OVERHAUL KIT

- 2 BJ 026 Port Screw
- 1 BJ 048-M Visc Fluid, Medium, 6oz
- 1 BJ 062-S Antiseize, 2g
- 1 GP 025-P2SS Front Jet Plug
- 1 TR200 121 Head - Shaft O-Ring
- 2 WG 008 Nut O-Ring
- 1 WG 014 Bearing Wave Spring
- 2 WGR 006 Shaft Seal - Outer

- 2 WGR 007 Bearing
- 2 WGR 010 Shaft Seal - Inner
- 2 WGR 011 Seal Spacer
- 6 WGR 030 Torx Screws
- 2 WGR 052 HP Seal Wave Spring
- 1 WGR 058-M90 HP Seal - Shaft
- 1 WGR 059-M90 HP Seal - Nut
- 1 WGR 076 Weep Seal O-Ring
- 1 WGR 180 Torx L-Wrench
- 2 WS 210 HP Seal O-Ring

WGR 612 - TOOL KIT

- 1 WGR 180 Torx L-Wrench
- 1 WGR 181 Removal Press Tube
- 1 WGR 182 Installation Press Tube
- 1 WGR 183 Hex Tool

- 1 WGR 184 HP Seal Install Tool
- 1 WGR 186 HP Seal Puller
- 1 SC287 105 Front Nut Wrench

1. Acceptance of Terms and Conditions. These Terms and Conditions shall operate as Seller's acceptance of Buyer's purchase order, and such acceptance is made expressly conditional on assent by Buyer to the Terms and Conditions. Such assent shall be deemed to have been given unless written notice of objection to any of such Terms and Conditions (including inconsistencies between Buyer's purchase order and this acceptance) is given by Buyer to Seller promptly on receipt hereof.

Seller desires to provide its Buyer with prompt and efficient service. However, to negotiate individually the terms of each sales contract would substantially impair Seller's ability to provide such service. Accordingly, products furnished and services rendered by Seller are sold only on the Terms and Conditions stated herein. Notwithstanding any Terms or Conditions on Buyer's order, Seller's performance of any contract is expressly made conditional on Buyer's agreement to Seller's Terms and Conditions of sale unless otherwise specifically agreed to in writing by Seller. In the absence of such agreement, commencement of performance, shipment and/or delivery shall be for Buyer's convenience only and shall not be deemed or construed to be an acceptance of Buyer's Terms and Conditions. PRODUCTS SOLD BY SELLER ARE DESIGNED AND INTENDED TO BE USED AT HIGH PRESSURES AND SPEEDS, AND MAY BE DANGEROUS IF OPERATED IMPROPERLY OR WITHOUT THE USE OF APPROPRIATE SAFETY DEVICES AND GUARDS. BUYER IS CAUTIONED TO CAREFULLY READ AND UNDERSTAND THESE TERMS AND CONDITIONS, AS THEY HAVE IMPORTANT LEGAL CONSEQUENCES.

2. Payment/Prices. Unless other arrangements have been made in writing between Seller and Buyer, payment for product delivered shall be made upon receipt of invoice. The prices shown on the face hereof are those currently in effect. Prices invoiced shall be per price list in effect at the time of shipment. Prices are subject to increase for inclusion of any and all taxes which are applicable and which arise from the sale, delivery or use of Seller's products or services and for the collection of which Seller is or may be responsible to any governmental authority unless acceptable exemption certificates are provided by Buyer in accordance with law. Buyer shall pay all charges for transportation and delivery and all excise, order, occupation, use or similar taxes, duties, levies, charges or surcharges applicable to the equipment or services being purchased, whether now in effect or hereafter imposed by any governmental authority, foreign or domestic.

3. Warranty. Subject to the limitations and conditions hereinafter set forth, Seller warrants to the original Buyer that its products are free from defects in workmanship and material for a period of one (1) year months from shipment. Seller's obligation under this warranty shall be limited to repairing, replacing or issuing a credit for, at Seller's option, any products or services it finds to be defective in material or workmanship. In no event shall Seller be liable for any incidental, consequential or indirect damages of any kind. THIS WARRANTY SHALL BE IN LIEU OF ANY OTHER WARRANTY, EXPRESSED OR IMPLIED, INCLUDING ANY WARRANTY FOR MERCHANTABILITY OR FITNESS FOR ANY PARTICULAR PURPOSE. No statement or recommendation made by Seller or its representative to Buyer or User shall constitute a warranty by Seller or a waiver or modification to any of the provisions hereof or create any liability for Seller. All warranty claims are subject to the exclusions and limitations set forth below:

a. The warranty shall not apply if the product or service (1) has been subject to misuse, negligence or accident; (2) has not been installed or operated in accordance with Seller's recommendations; (3) has been operated under more severe conditions than those specified for the particular product or service; (4) has been operated beyond the rated capacity of the product; or (5) has been repaired or altered outside Seller's facilities or in any way so as, in Seller's judgment, to affect its stability or reliability.

b. Products that Seller furnishes, but does not manufacture, carry only the warranty of the manufacturer of such products. Where other manufacturers' or suppliers' products used in Seller's products or services prove defective, Seller's liability shall exist only to the extent that Seller is able to recover from such manufacturers or suppliers for such defects.

c. Any warranty granted by Seller to the Buyer shall be deemed void if any goods covered by such warranty are used for any purpose not recommended or permitted. In addition, the Buyer shall indemnify Seller and hold Seller harmless from and against any and all claims, damages, losses, costs, expenses and other liability of whatever nature that Seller suffers or incurs by reason of any such unintended use.

d. Notice of defective product or service must be given in writing to Seller by Buyer or User within fifteen (15) business days following receipt of goods. Buyer or User shall keep such products or services in an unaltered condition for examination by Seller's representative. No goods may be returned for credit or adjustment without prior written permission from Seller.

4. Product Liability. Buyer specifically acknowledges that the products being purchased may be operated at high speeds and/or pressures, and that as such they may be inherently dangerous if not used correctly. Buyer shall be solely responsible for the safe operation of the products at all times and for determining the safety devices and guards that may be required for the safe operation of the products. Buyer shall undertake to specify and order all safety devices and guards necessary for the safe operation of the equipment covered. All safety devices and guards offered in Seller's quotations are recommended for purchase. Seller may provide necessary safety devices and guards not offered in this quotation at an extra price in accordance with the specifications of Buyer. Buyer shall at all times use and require its employees to use all necessary and appropriate safety devices, guards and proper safe operating procedures. Buyer shall not remove or modify any such devices, guards or warning signs and shall insist on safe operating practices on the part of its personnel. In no event shall Seller be responsible for any injuries to persons or property caused by defects in any equipment, including by way of illustration and not limitation, any pumps, compressors, fittings, connections, components, piping or hoses up to the point that same are connected to the product. Buyer agrees to indemnify and to save Seller harmless from any and all liability or obligation incurred by or against Seller, including costs and attorneys' fees, to or by any

persons injured directly or indirectly in the operation of the equipment furnished under the following conditions:

- a. if Buyer fails to purchase and use necessary and appropriate safety devices and guards as determined and/or recommended by Seller;
- b. if Buyer fails to maintain in good working order such safety devices and guards as are purchased from Seller;
- c. if Buyer adds, omits, repairs, modifies, replaces or substitutes any components on the equipment without permission from Seller;
- d. if Buyer exceeds at any time the maximum safe loads, pressures or speeds recommended by Seller for the equipment furnished hereunder without the specific written consent of Seller; or
- e. if Buyer otherwise fails to operate the product or equipment in accordance with Seller's printed instructions or otherwise negligently operates the equipment.

5. Delivery. Seller is not obligated to make delivery by a specified date, but will always use its best efforts to make delivery within the time requested. All deliveries are based on F.O.B. Seller's factory, unless specifically agreed otherwise, and Buyer shall pay all shipping costs and insurance from that point. Seller, in its sole discretion, will determine and arrange the means and manner of transportation of the products. Responsibility of Seller shall cease and Buyer assumes all risk of loss or damages upon Seller's delivery to and receipt by a common carrier. Carriers shall be responsible for goods lost or damaged in transit and Buyer shall immediately notify the carrier in writing of such loss or damage. At Buyer's request Seller will offer its assistance. THE PROPOSED SHIPMENT DATE IS AN ESTIMATE. UNDER NO CIRCUMSTANCES SHALL SELLER HAVE ANY LIABILITY WHATSOEVER FOR LOSS OF USE OR FOR ANY DIRECT OR CONSEQUENTIAL DAMAGES RESULTING FROM DELAY REGARDLESS OF THE REASON(S). Shortages or errors must be reported within fifteen (15) business days from receipt of shipment to secure adjustment. No merchandise may be returned without securing written approval from Seller. Seller will notify Buyer promptly of any material delay and will specify the revised delivery date as soon as practicable. Seller shall not be liable for any delay in delivery or performance, or for any failure to manufacture, deliver or perform due to (a) any cause beyond its reasonable control; (b) any act of God, act of Buyer, act of civil or military authority, governmental priority, strike or other labor disturbance, flood, epidemic, war, riot, delay in transportation or car shortage; or (c) inability on account of any cause beyond the reasonable control of Seller to obtain necessary materials, components, services or facilities. In the event of any such delay, the date of delivery or of performance shall be extended for a period equal to the time lost by reason of the delay.

6. Technical Advice. All technical advice, recommendations and services of Seller are intended for use by persons having adequate skill, at their own risk, and Seller assumes no responsibility, and Buyer hereby waives all claims against Seller, for results obtained or damages incurred from the use of Seller's advice, recommendations and services.

7. Modification. These Terms and Conditions are intended by Seller and Buyer to constitute a final, complete and exclusive expression of agreement and cannot be supplemented or amended without Seller's prior written approval. Seller's waiver of any breach, or failure to enforce any of the Terms and Conditions at any time, shall not in any way affect, limit or waive Seller's right thereafter to enforce and compel strict compliance with every Term and Condition thereof. If any provisions of these Terms and Conditions are held to be invalid or unenforceable, such invalidity or unenforceability shall not affect the validity or enforceability of the other portions hereof.

8. Disputes. Buyer and Seller shall attempt in good faith promptly to resolve any dispute arising under these Terms and Conditions by negotiations between representatives who have authority to settle the controversy. If unsuccessful, Buyer and Seller shall further attempt in good faith to settle the dispute by nonbinding third-party mediation, with fees and expenses of such mediation apportioned equally to each side. Any dispute not so resolved by negotiation or mediation may then be submitted to a court of competent jurisdiction in accordance with the terms hereof. These procedures are the exclusive procedures for the resolution of all such disputes between the parties. All sales, agreements for sale, offers to sell, proposals, acknowledgments and contracts of sale, including, but not limited to, purchase orders accepted by Seller, shall be considered a contract under the laws of the State of Colorado and the rights and duties of all persons, and the construction and effect of all provisions hereof shall be governed by and construed according to the laws of such state. A state or federal court located within the State of Colorado shall have sole and exclusive jurisdiction over any litigation concerning any such matters as well as any alleged defects of any products or equipment covered thereby or damages sustained as a result of such alleged defects. If any litigation is commenced between Seller and Buyer, or their personal representatives, concerning any provision hereof, the party prevailing in the litigation shall be entitled, in addition to such other relief that is granted, to a reasonable sum as and for their attorneys' fees and costs in such litigation or arbitration.

STONEAGE TRADEMARK LIST

View the list of StoneAge's trademarks and service marks and learn how the trademarks should be used. Use of StoneAge trademarks may be prohibited, unless expressly authorized.

<http://www.StoneAgeTools.com/trademark-list/>

STONEAGE PATENT DATA

View the list of StoneAge's current U.S. patent numbers and descriptions.

<http://www.sapatents.com>



1-866-795-1586 • www.STONEAGETOOLS.com

© 2014 StoneAge, Inc. All Rights Reserved