

# Galanz

Model: P70B20AL-TL1

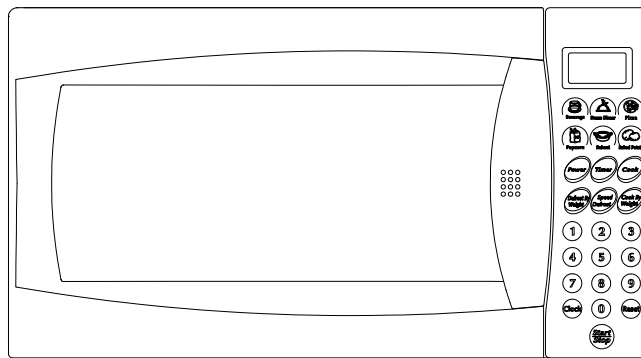

**Microwave Oven**

**User's manual**

1. Please read these instructions carefully before installing and operating the oven. Keep them for further reference.
2. Record in the space below the SERIAL NO. found on the nameplate on your oven and retain this information for future reference.

SERIAL NO.:

3. Please save sales receipt for warranty.

## PRECAUTIONS TO AVOID POSSIBLE EXPOSURE TO EXCESSIVE MICROWAVE ENERGY

1. Do not attempt to operate this oven with the door-open since open-door operation can result in harmful exposure to microwave energy. It is important not to defeat or tamper with the safety interlocks.
2. Do not place any object between the oven front face and the door or allow soil or cleaner residue to accumulate on sealing surfaces.
3. Do not operate the oven if it is damaged. It is particularly important that the oven door close properly and that there is no damage to the:
  - a. Door (bent),
  - b. Hinges and latches (broken or loosened),
  - c. Door seals and sealing surfaces.
4. The oven should not be adjusted or repaired by anyone except properly qualified service personnel.

### CONTENT

PRECAUTIONS TO AVOID POSSIBLE EXPOSURE TO EXCESSIVE MICROWAVE ENERGY .....	1
IMPORTANT SAFETY INSTRUCTIONS.....	2
INSTALLATION GUIDE .....	4
GROUNDING INSTRUCTIONS.....	4
UTENSILS GUIDE .....	5
COOKING TECHNIQUES.....	6
SPECIFICATIONS.....	7
PART NAMES .....	7
CONTROL PANEL .....	8
OPERATION INSTRUCTIONS .....	9
Setting the clock.....	9
Setting a cooking program .....	9
Speed defrost .....	9
Cook by weight.....	10
Defrost by weight.....	10
Setting child lock .....	10
QUICK COOK SETTINGS .....	11
POPCORN .....	11
BAKED POTATO .....	11
PIZZA .....	11
BEVERAGE.....	11
FROZEN DINNER.....	11
REHEAT .....	11
CLEANING AND CARE.....	12

## IMPORTANT SAFETY INSTRUCTIONS

When using electrical appliances, basic safety precautions should be followed, including the following:

**WARNING** - To reduce the risk of burns, electric shock, fire, and injury to persons or exposure to excessive microwave energy:

1. Read all instructions before using the appliance.
2. Read and follow the specific "PRECAUTIONS TO AVOID POSSIBLE EXPOSURE TO EXCESSIVE MICROWAVE ENERGY" on page 1.
3. This appliance must be grounded. Connect only to properly grounded outlet. See "GROUNDING INSTRUCTIONS" on page 4.
4. Install or locate this appliance only in accordance with the provided installation instructions.
5. Some products such as whole eggs and sealed containers -for example, closed glass jars- are able to explode and should not be heated in this oven.
6. Use this appliance only for its intended use as described in this manual. Do not use corrosive chemicals or vapors in this appliance. This type of oven is specifically designed to heat, cook, or dry food. It is not designed for industrial or laboratory use.
7. As with any appliance, close supervision is necessary when used by children.
8. To reduce the risk of fire in the oven cavity:
  - a. Do not overcook food. Carefully attend appliance when paper, plastic, or other combustible materials are placed inside the oven to facilitate cooking.
  - b. Remove wire twist-ties from paper or plastic bags before placing bag in oven.
  - c. If materials inside the oven should ignite, keep oven door closed, turn oven off, and disconnect the power cord or shut off power at the fuse or circuit breaker panel.

d. Do not use the cavity for storage purposes. Do not leave paper products, cooking utensils or food in the cavity when not in use.

9. Liquids, such as water, coffee, or tea can be overheated beyond the boiling point without appearing to be boiling due to surface tension of the liquid. Visible bubbling or boiling when the container is removed from the microwave oven is not always present. **THIS COULD RESULT IN VERY HOT LIQUIDS SUDDENLY BOILING OVER WHEN A SPOON OR OTHER UTENSIL IS INSERTED INTO THE LIQUID.** To reduce the risk of injury to person:

- 1) Do not overheat the liquid.
  - 2) Stir the liquid both before and halfway through heating it.
  - 3) Do not use straight-sided containers with narrow necks.
  - 4) After heating, allow the container to stand in the microwave oven for a short time before removing the container.
  - 5) Use extreme care when inserting a spoon or other utensil into the container.
10. Do not heat oil or fat for deep-frying. It is difficult to control the temperature of oil in microwave oven.
11. Pierce foods with heavy skins such as potatoes, whole squash, apples and chestnuts before cooking.
12. The contents of feeding bottles and baby jars should be stirred or shaken and the temperature should be checked before serving in order to avoid burns.
13. Cooking utensils may become hot because of heat transferred from the heated food. Potholders may be needed to handle the utensil.
14. Do not cover or block any openings on the appliance.
15. Do not store or use this appliance outdoors. Do not use this product near water, for example, near a kitchen sink, in a wet basement, near a swimming pool, or similar

locations.

16. Do not operate this appliance if it has a damaged cord or a plug, if it is not working properly or if it has been damaged or dropped.

17. Do not immerse cord or plug in water. Keep cord away from heated surface. Do not let cord hang over edge of table or counter.

18. Use only thermometers, which are specifically designed for use in microwave ovens.

19. Do not operate any heating or cooking appliance beneath this appliance.

20. Be certain the glass tray and roller rings are in place when you operate the oven

21. This appliance should be serviced only by qualified service personnel, contact nearest authorized service facility for examination, repair, or adjustment.

22. When cleaning surfaces of door and oven that comes together on closing the door, use only mild, nonabrasive soaps, or detergents applied with a sponge or soft cloth.

**SAVE THESE INSTRUCTIONS**



## INSTALLATION GUIDE

1. Make sure that all the packing materials are removed from the inside of the door.
2. Check the oven for any damage, such as misaligned or bent door, damaged door seals and sealing surface, broken or loose door hinges and latches and dents inside the cavity or on the door. If there is any damage, do not operate the oven but contact qualified service personnel.
3. This microwave oven must be placed on a flat, stable surface to hold its weight and the heaviest food likely to be cooked in the oven.
4. Do not place the oven where heat, moisture, or high humidity are generated, or near combustible materials.
5. For correct operation, the oven must have sufficient airflow. Allow 20cm of space above the oven, 10cm at back and 5cm at both sides. Do not cover or block any openings on the appliance. Do not remove feet on which oven stands.
6. Do not operate the oven without glass tray, roller support, and shaft in their proper positions.
7. Make sure that the power supply cord is undamaged and does not run under the oven or over any hot or sharp surface.
8. The socket must be readily accessible so that it can be easily unplugged in an emergency.

## GROUNDING INSTRUCTIONS

This appliance must be grounded. In the event of an electrical short circuit, grounding reduces risk of electric shock by providing an escape wire for the electric current.

**WARNING** Improper use of the grounding plug can result in a risk of electric shock.

Consult a qualified electrician or serviceman if the grounding instructions are not completely understood, or if doubt exists as to whether the appliance is properly grounded, and either:

1) If it is necessary to use an extension cord, use only a 3-wire extension cord that has a 3-blade grounding plug and a 3-slot receptacle that will accept the plug on the

appliance. The marked rating of the extension cord shall be equal to or greater than the electrical rating of the appliance, or 2) Do not use an extension cord. If the power supply cord is too short, have a qualified electrician or serviceman install an outlet near the appliance.

### ELECTRICAL REQUIREMENTS

The electrical requirements are a 120 volt 60 Hz, AC only, 15 amp. It is recommended that a separate circuit serving only the oven be provided. The oven is equipped with a 3-prong grounding plug. It must be plugged into a wall receptacle that is properly installed and grounded.

## POWER SUPPLY CORD

1. A short power supply cord is provided to reduce the risks resulting from becoming entangled in or tripping over a longer cord.
2. Longer cord sets or extension cords are available and may be used if care is exercised in their use.
3. If long cord or extension cord is used:
  - a) The marked electrical rating of the cord set or extension cord should be at least as great as the electrical rating of the appliance.
  - b) The extension cord must be a grounding-type 3-wire cord, and The longer cord should be arranged so that it will not drape over the counter top or table top where it can be pulled on by children or tripped over

unintentionally.

Notes:

If you have any questions about the grounding or electrical instructions, consult a qualified electrician or service person.

Neither the manufacturer nor the dealer can accept any liability for damage to the oven or personal injury resulting from failure to observe the electrical connection procedures.

### Radio or TV Interference

Should there be any interference caused by the microwave oven to your radio or TV, check that the microwave oven is on a different circuit, relocated the radio or TV as far away from the oven as feasible or check position and signal of receiving antenna.

## UTENSILS GUIDE

This section lists which utensils can be used in the microwave, which ones have limited use for short periods, and which ones should not be used in the microwave.



### RECOMMENDED

**Microwave browning dish** — Use to brown the exterior of small items such as steaks, chops, or pancakes. Follow the directions provided with your browning dish.

**Microwaveable plastic wrap** — Use to retain steam. Leave a small opening for some steam to escape and avoid placing it directly on the food.

**Paper towels and napkins** — Use for short-term heating and covering; these absorb excess moisture and prevent spattering. Do not use recycled paper towels, which may contain metal and could ignite.

**Glass and glass-ceramic bowls and dishes** — Use for heating or cooking.

**Paper plates and cups** — Use for short-term

heating at low temperatures. Do not use recycled paper, which may contain metal and could ignite.

**Wax paper** — Use as a cover to prevent spattering.

**Thermometers** — Use only those labeled "Microwave Safe" and follow all directions. Check the food in several places. Conventional thermometers may be used on microwave food once the food has been removed from the oven.

### A LIMITED USE

**Aluminum foil** — Use narrow strips of foil to prevent overcooking of exposed areas. Using too much foil can damage your oven, so be careful. You should keep distance of 1 inch (2.54cm) between aluminum foil and cavity.

**Ceramic, porcelain, and stoneware**— Use these if they are labeled "Microwave Safe". If they are not labeled, test them to make sure they can be used safely.

**Plastic** — Use only if labeled "Microwave Safe". Other plastics can melt.

## ✘ Not Recommended

**Glass jars and bottles** — Regular glass is too thin to be used in a microwave. It can shatter and cause damage and injury.

**Paper bags** — These are a fire hazard, except for popcorn bags that are designed for microwave use.

**Styrofoam plates and cups** — These can melt and leave an unhealthy residue on food.

**Plastic storage and food containers** — Containers such as margarine tubs can melt in the microwave.

**Metal utensils** — These can damage your oven. Remove all metal before cooking.

### **Note:**

Should you wish to check if a dish is safe for microwaving, place the empty dish in the oven and microwave on HIGH for 30 seconds. A dish which becomes very hot should not be used.

## COOKING TECHNIQUES

Your microwave makes cooking easier than conventional cooking, provided you keep these considerations in mind:

### **STIRRING**

---

Stir foods such as casseroles and vegetables while cooking to distribute heat evenly. Food at the outside of the dish absorbs more energy and heats more quickly, so stir from the outside to the center. The oven will turn off when you open the door to stir your food.

### **ARRANGEMENT**

---

Arrange unevenly shaped foods, such as chicken pieces or chops, with the thicker, meatier parts toward the outside of the turntable where they receive more microwave energy. To prevent overcooking, place delicate areas, such as asparagus tips, toward the center of the turntable.

### **SHIELDING**

---

Shield food with narrow strips of aluminum foil to prevent overcooking. Areas that need shielding include poultry wing tips, the ends of poultry legs, and corners of square baking dishes. Use only small amounts of aluminum foil. Larger amounts can damage your oven.

### **TURNING**

---

Turn foods over midway through cooking to expose all parts to microwave energy. This is especially important with large foods such as roasts.

### **STANDING**

---

Foods cooked in the microwave build up internal heat and continue to cook for a few minutes after heating stops. Let foods stand to complete cooking, especially foods such as cakes and whole vegetables. Roasts need this time to complete cooking in the center without overcooking the outer areas. All liquids, such as soup or hot chocolate, should be shaken or stirred when cooking is complete. Let liquids stand a moment before serving. When heating baby food, stir well at removal and test the temperature before serving.

### **ADDING MOISTURE**

---

Microwave energy is attracted to water molecules. Food that is uneven in moisture content should be covered or allowed to stand so that the heat disperses evenly. Add a small amount of water to dry food to help it cook.

## SPECIFICATIONS

<b>Power Consumption:</b>	120V~60Hz, 1050W (Microwave)
<b>Output:</b>	700W
<b>Operation Frequency:</b>	2450MHz
<b>Outside Dimensions(H×W×D):</b>	10 5/16×17 13/16×12 13/16 in.
<b>Oven Cavity Dimensions(H×W×D):</b>	8 11/16×12 3/8×11 9/16 in.
<b>Oven Capacity:</b>	0.7cu.ft
<b>Cooking Uniformity:</b>	Turntable System
<b>Net Weight:</b>	Approx. 23.1 lb.

## PART NAMES

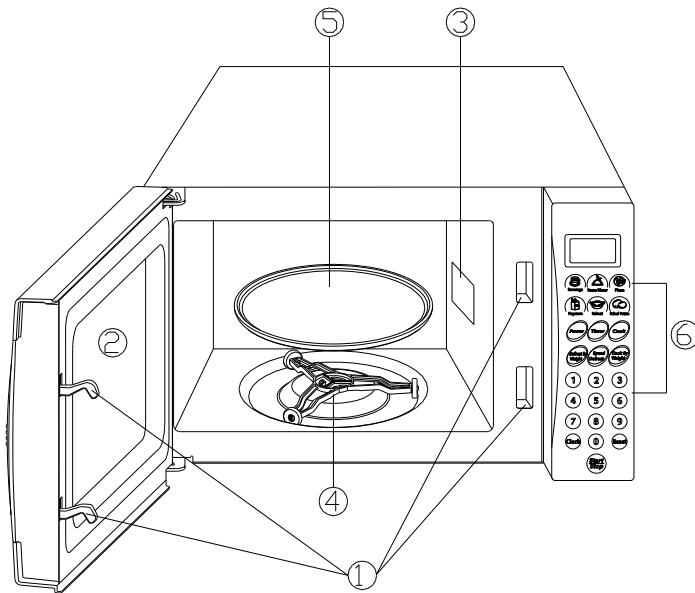

1. Door Safety Lock System
2. Oven Window
3. Wave Guide
4. Roller Ring
5. Glass Tray
6. Control Panel



# CONTROL PANEL

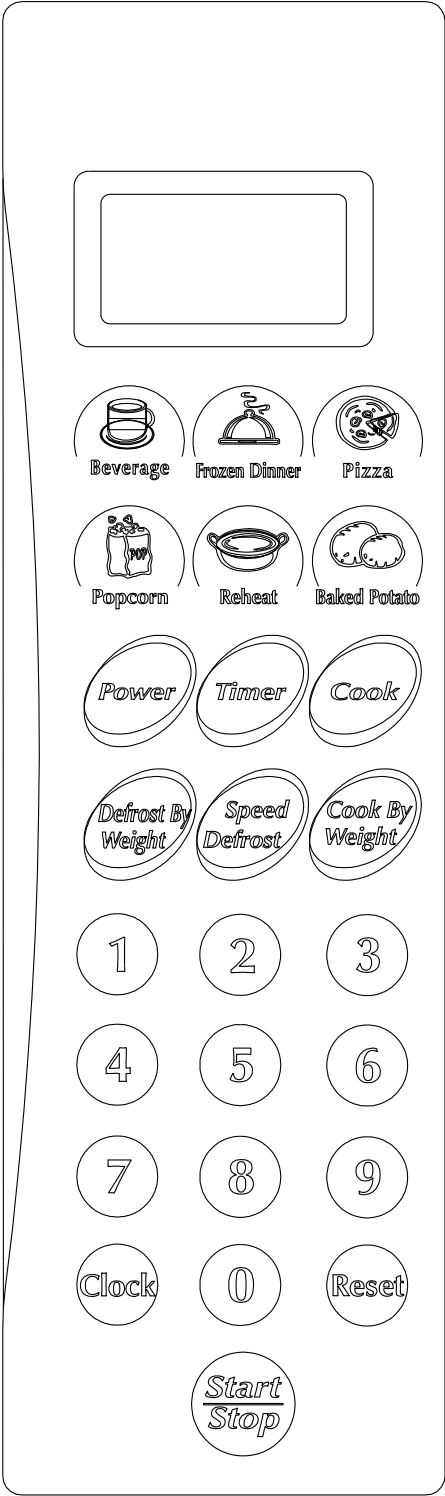

- **MENU ACTION SCREEN**  
Cooking time, power, indicators and present time are displayed.
- **QUICK COOK BUTTONS**  
Instant settings to cook popular foods.
- **POWER**  
Use to set power levels other than high.
- **TIMER**  
Timer functions independently, even while a cooking program is in process.
- **COOK**  
Use for multi-stage cooking. Enables cooking at multiple power and time settings automatically.
- **DEFROST BY WEIGHT**  
Programmed defrosting based on the weight of the foods to be defrosted.
- **SPEED DEFROST**  
Programmed defrosting based on the time user entered.
- **COOK BY WEIGHT**  
Programmed cooking based on weight of foods to be cooked.
- **NUMBER PADS(0-9)**  
Touch to set time or amount.
- **CLOCK**  
Touch this button to start setting the oven clock and ending by touching it again.
- **RESET**  
Clears all previous settings before setting another function or be used to set and release Child Lock function.
- **START/STOP**  
Touch to start or stop cooking.

# OPERATION INSTRUCTIONS

0

0%

## SETTING THE CLOCK

1. Touch CLOCK pad.
2. Use the number pads to enter the correct time.
3. Touch CLOCK pad again.

### NOTE:

- This is a 12 hour clock. When the oven is first plugged in or when power resumes after a power interruption, the display will show ENTER CLOCK TIME. If you prefer to not have the clock displayed, touch RESET.
- You can check the clock time while cooking is in progress by touching the CLOCK pad.

## SETTING A COOKING PROGRAM

### A. One-stage Cooking

1. Use the number pads to set a cooking time. You can set a cooking time from one second to 99 minutes and 99 seconds.
2. If you want to set a power level other than 100% power, touch POWER, then use the number pads to enter the power level.
3. Touch START/STOP to start cooking.

Use single digits to set a cooking power level:

Number pad	Cooking power
1,0	100%
9	90%
8	80%
7	70%
6	60%
5	50%
4	40%
3	30%
2	20%
1	10%

### B. Two-stage Cooking

Some recipes require different stages of cooking at different temperatures.

#### 1. SET STAGE 1:

Follow steps 1 and 2 in "One-stage Cooking". DO NOT TOUCH START/STOP

#### 2. SET STAGE 2:

Touch COOK then enter proper cooking time and (lower) power level. (Most 2-stage recipes use lower power for second stage.)

#### 3. Touch START/STOP.

## SPEED DEFROST

1. Touch SPEED DEFROST.
2. Enter desired defrosting time by touching correct number pads (the longest cooking time you can set is 99minutes and 99seconds).
3. Touch START/STOP.

### NOTE:

During defrosting program, the system will pause and sound beeps to remind user to turn food over, and then press START/STOP to resume the defrosting.

- After setting SPEED DEFROST, oven can be programmed to automatically switch to one or two-stage cooking.

- For speed defrost and one stage cooking, follow steps above. Before touching START/STOP, touch COOK, enter time and power level. Then touch START/STOP.

- For speed defrost and two stage cooking, follow steps above. Before touching START/STOP, enter two-stage cooking programs.

## COOK BY WEIGHT

1. Touch COOK BY WEIGHT.
2. Enter the one digit code by touching the correct number pad (1~3).
3. Touch number pad to enter weight.
4. Touch START/STOP.

### Cook By Weight Code Description

CODE	TYPE	MAX WEIGHT
1	Beef	5 lb. 16 oz.
2	Mutton	5 lb. 16 oz.
3	Pork	5 lb. 4 oz.

Note:

- Meat must be defrosted and at refrigerated temperature.
- Weight must be in pounds and ounces.
- Ounce weights less than 10 must be preceded by a 0. If label gives weight in pounds only, change the fraction of a pound to ounces using the following chart.

### Converting Fractions of a Pound to Ounces

Fractions of a pound	Ounces
Less than .03	0
.03 to .09	1
.10 to .15	2
.16 to .21	3
.22 to .27	4
.28 to .34	5
.35 to .40	6
.41 to .46	7
.47 to .53	8
.54 to .59	9
.60 to .65	10
.66 to .71	11
.72 to .78	12

.79 to .84	13
.85 to .90	14
.91 to .97	15
above .97	go to next even

- During cooking, the system will pause and sound beeps to remind user to turn food over, and then press START/STOP to resume cooking.

- Let meat stand few minutes before carving.

## DEFROST BY WEIGHT

1. Touch DEFROST BY WEIGHT pad.
2. Touch number pad to enter weight.
3. Touch START/STOP pad.

NOTE:

- Weight must be in pounds and ounces. Ounce weights less than 10 must be preceded by a 0. If label gives weight in pounds only, change the fraction of a pound to ounces using the chart given above. The maximum weight of food is 5 lb. 16 oz.
- During defrosting program, the system will pause and sound beeps to remind user to turn food over, and then press START/STOP to resume the defrosting.

## SETTING CHILD LOCK

The safety lock prevents unsupervised operation by children.

To set, press and hold RESET for 3 seconds. LOCK is indicated on the display.

To cancel, press and hold RESET for 3 seconds. LOCK indication disappears.

## QUICK COOK SETTINGS

The QUICK COOK settings allow you to cook or reheat food automatically without entering power level or time.

For smaller portions, simply touch the applicable pad and start. For larger portions, push the pad twice.

FROZEN DINNER, BAKED POTATO and BEVERAGE allow you to cook multiple amounts of the same food. Simply touch pad once, and ENTER AMT appears in the display. Enter the amount of servings and start.

### POPCORN

---

1. Touch POPCORN pad once.

POPCORN automatically sets the cooking time for a 3.5oz. /bag of microwave popcorn.

2. Touch START/STOP.

NOTE: To change the preset POPCORN time: Touch POPCORN pad twice. ENTER TIME appears in display. Touch number pads to enter minutes and seconds. Touch START/STOP. This new cooking time will remain whenever you use the POPCORN setting except the power is cut off.

### BAKED POTATO

---

**For 4 - 6 oz. /each share of potatoes:**

1. Touch BAKED POTATO pad once.
2. Enter number of potatoes by touching number pads from 1 to 4.
3. Touch START/STOP.

**For the large 8-10 oz. / each share of potatoes:**

1. Touch BAKED POTATO pad twice.
2. Enter number of potatoes by touching number pads from 1 to 4.
3. Touch START/STOP.

### PIZZA

---

**Reheating a slice of pizza:**

1. Touch PIZZA pad once.
2. Touch START/STOP.

**Heating a whole frozen pizza:**

1. Touch PIZZA pad twice.
2. Touch START/STOP.

### BEVERAGE

---

**For 5-7 oz. /each cup:**

1. Touch BEVERAGE pad once.
2. Enter number of cups by touching number pads from 1 to 4.
3. Touch START/STOP.

**For 9-11 oz. /each cup:**

1. Touch BEVERAGE pad twice.
2. Enter number of mugs by touching number pads from 1 to 4.
3. Touch START/STOP.

### FROZEN DINNER

---

**For one or two small (7-9oz./each share) of frozen dinners:**

1. Touch FROZEN DINNER pad once.
2. For 1 entree or 2 entrees, touch the number pad "1" or "2"
3. Touch START/STOP pad.

**Microwaving one large (10-12oz. /each share) of frozen dinner:**

1. Touch FROZEN DINNER pad twice.
2. For 1 entree or 2 entrees, touch the number pad "1" or "2":
3. Touch START/STOP.

### REHEAT

---

1. Touch REHEAT pad once.
2. Touch START/STOP.

## CLEANING AND CARE

1. Turn off the oven and remove the power plug from the wall socket before cleaning.
2. Keep the inside of the oven clean. When food splatters or spilled liquids adhere to oven walls, wipe with a damp cloth. Mild detergent may be used if the oven gets very dirty. Avoid the use of spray and other harsh cleaners as they may stain, streak or dull the door surface.
3. The outside surfaces should be cleaned with a damp cloth. To prevent damage to the operating parts inside the oven, water should not be allowed to seep into the ventilation openings.
4. Wipe the window on both sides with a damp cloth to remove any spills or spatters.
5. Do not allow the control panel to become wet. Clean with a soft, damp cloth. When cleaning the control panel, leave oven door open to prevent oven from accidentally turning on.
6. If steam accumulates inside or around the outside of the oven door, wipe with a soft cloth. This may occur when the microwave oven is operated under high humidity conditions. In such case, it is normal.
7. It is occasionally necessary to remove the glass tray for cleaning. Wash the tray in warm sudsy water or in a dishwasher.
8. The roller ring and oven floor should be cleaned regularly to avoid excessive noise. Simply wipe the bottom surface of the oven with mild detergent. The roller ring may be washed in mild sudsy water or dishwasher. When removing the roller ring from cavity floor for cleaning, be sure to replace in the proper position.
9. Remove odors from your oven by combining a cup of water with the juice and skin of one lemon in a deep microwaveable bowl, microwave for 5 minutes. Wipe thoroughly and dry with a soft cloth.
10. When it becomes necessary to replace the oven light, please consult a dealer to have it replaced.
11. The oven should be cleaned regularly and any food deposits removed. Failure to maintain the oven in a clean condition could lead to deterioration of the surface that could adversely affect the life of the appliance and possibly result in a hazardous situation.
12. Please do not dispose this appliance into the domestic rubbish bin, it should be disposed to the particular disposal center provided by the municipalities.

Distributed by Guangdong Galanz Microwave Oven and Electrical Appliances Manufacturing co.,Ltd.  
Shunde, Foshan, Guangdong, 528305, China  
For service, support and warranty information, call 1-866-257-3336.