

TECHNICAL DATA

CWR-264P Specifications

Physical

Size

Length: 19.0"
Height: 7.8" (10.5" of rack space)
Depth: 3.2"

Weight

4lb.

Environmental

Storage

Temperature: -50°C to 85°C
Humidity: 0 to 95%, non-condensing

Operating

Temperature: -40°C to 72°C
Humidity: 0 to 95%, non-condensing

Mounting

Standard: mounts in 19" rack
Optional: 23" rack mounting brackets available

Construction

Chassis

Fully enclosed, anodized aluminum
 Externally accessible keypad, LEDs and connectors

Electrical

All components mounted on conformal coated, internal PCBs

Power

Voltage

Range: 10 to 36Vdc

Consumption

Typical: 6W
Maximum: 7W

Isolation

Power

Minimum: 3800Vdc from B and N terminals to chassis

Internal Modem

Designed to meet FCC part 68 standards

Ethernet Port

Minimum: 3800Vdc to any terminal

Capacities

CWR-264S

1 to 16 Secondary Units

Programmable Inputs

Virtual: 32, user assigned
Timer: 999, user assigned

Outputs

Relays: 4, dual form C, rated for 2A at 24Vdc or 1A at 125Vac, maximum switching capacity of 125VA or 60W, service life 1 million electrical (typical)

Event Storage

Standard: 1,816,045 records
Memory Full: 129th day overwrites first day, newest data overwrites oldest data

Ethernet Port

Quantity: 1
Type: 10/100 Base-T

RS-232 Port

Quantity: 2, for use with a PC
Emulation: ANSI
Baud Rates: 300, 600, 1200, 2400, 4800, 9600, 19,200, 38,400, 57,600, 115,200
Bit Format: N-8-1

Printer Port

Quantity: 1, parallel, for use with inkjet and laserjet printers

Capacities (continued)

Liquid Crystal Display

Characters: 80 total on 4 lines
Character Set: A-Z upper- and lower-case, 0-9, various symbols
Viewing Area: 2.8" by .8"

Front Panel Keypad

Quantity: 20 keys
Keys: 0-9, Browse, Alpha, Setup, Esc, Enter, Print, left, right, up/., down/-

Virtual Inputs

Quantity

32, user assigned

Definitions

Any logical association shared by 1 to 4 variables (i.e., Digital, Analog, Timer or Virtual Inputs)

Assigned by defining the state of the Virtual Input for each combination of variable states

Reporting

Creates standard Event Record
 Relays can be controlled by each Virtual Input
 Modem can be set up to dial-out Event Record

Timer Inputs

Quantity

999, user assigned

Programming

Any Digital, Analog, Virtual or Timer Input can be assigned as the trigger source

Any Digital, Analog or Virtual Input can be assigned as the terminating source

On or Off events can be assigned as the trigger or terminating source

Timer Inputs (continued)

Limit Values

Separate high and low limits per assigned Timer Input, in multiples of .1 seconds

Range: 0.0 to 999.9 seconds

Reporting

Measured Time is reported in each Timer Input Event Record

Violation of Limit Values are also reported

Train Speed Monitor

Quantity

16 total, separately programmable

Operation

Reports excessive train speed

Logs standard Event Record

Sensors are wired to 2 spare Digital Inputs

Limit Values

5 to 180mph

Distance between Sensors

50' to 5280'

Memory

Type

Non-volatile, Event Records and Setup Database are stored in flash memory chips

Storage Longevity

Infinite with power off

Rated for 1 million write operations

Connectors

Terminal Ports (2)

DE-9 male, configured as DCE

Printer Port

DB-25 female, standard parallel printer configuration

Power

Detachable, screw-down, 4-position, 12 to 22AWG

Dual B and N terminals

Connectors (continued)

Alarm Relays

Detachable, screw-down, 12-position, 12 to 22AWG

4 sets of N.O., N.C. and common

Telephone Line (2)

RJ-11 female, wired in parallel

Ethernet Port

RJ-45 female

Controls

Keypad

20 keys, located on front panel

LCD Contrast Adjust

Single-turn potentiometer, located on front panel

Indicators

LCD Panel

Includes LED back lighting for enhanced visibility

Displays numerous command menus for configuring the recorder and retrieving data

LEDs (3)

Power: green

Terminal: green, flashes with send/rcv data

Modem: green, flashes with send/rcv data and ring-in

Internal Clock

Accuracy

Typical: ± 1 minute per month (20ppm)

Sync: spare Digital Input used to synchronize real-time clock of Primary Unit

Synchronizes clock of Secondary Unit(s) every 10 seconds

Resolution

Event Records are time stamped to nearest .01 seconds

Operation

Full calendar, auto-adjusted for leap year

Non-volatile with power off

Y2K compliant

Password Protection

Administrative Level

Access to all functions, limit 8 characters

Restricted Level

Access to Event Record and Setup Database viewing only, limit 8 characters

Passcode

Protects against alterations to Setup Database via front panel, limit 8 digits

Internal Modem

Type

V.34, 33,600 Baud, data compression and error correction

Usage

Remote access via auto-answer operation

Allows dial-out alarm reporting of Virtual Input records

Compliance

Designed to meet FCC part 68 standards

Dial-out Alarms

Calling Method

Primary and secondary dial numbers, multiple attempts

Tone or pulse dialing

Data

Issues Event Record for enabled Virtual Inputs

Ethernet Port

Type: 10/100 Base-T

Usage: normally connected to LAN via CAT-5 cable to Ethernet Switch

Speed: 100Mbps

Protocol: TCP/IP, Telnet

LED Indicators: Green - link established; Yellow - data activity

MICRO-AIDE reserves the right to make changes, at its sole discretion, to any specifications listed herein.

CWR-264S Specifications

Physical

Size

Length: 19.0"
Height: 7.8" (10.5" of rack space)
Depth: 3.8"

Weight

7lb.

Environmental

Storage

Temperature: -50°C to 85°C
Humidity: 0 to 95%, non-condensing

Operating

Temperature: -40°C to 72°C
Humidity: 0 to 95%, non-condensing

Mounting

Standard: mounts in 19" rack
Optional: 23" rack mounting brackets available

Construction

Chassis

Fully enclosed, anodized aluminum
Externally accessible LED and connectors

Electrical

All components mounted on conformal coated, internal PCBs

Power

Voltage

Range: 10 to 36Vdc

Consumption

Typical: 6W
Maximum: 7W

Isolation

Power

Minimum: 3800Vdc from B and N terminals to chassis and inputs

Digital Inputs

Minimum: 3800Vdc to any terminal

Analog Inputs

Minimum: 3800Vdc to any terminal

Isolation (continued)

Input to Adjacent Input

Digital: minimum 3800Vdc
Analog: minimum 3200Vdc

Ethernet Port

Minimum: 3800Vdc to any terminal

Capacities

Inputs

Digital: 256, all opto-isolated
Analog: 8 total, 4 can measure current

Event Storage

Standard: 100,000 Event Record buffer used to save records before polling by Primary Unit
Type: non-volatile flash memory

Ethernet Port

Quantity: 1
Type: 10/100 Base-T

RS-232 Port

Quantity: 1, for use with a PC
Usage: serves as a diagnostic port
Emulation: ANSI
Baud Rates: 300, 600, 1200, 2400, 4800, 9600, 19,200, 38,400, 57,600, 115,200
Bit Format: N-8-1

Inputs

Input Impedance

Digital: minimum 10KOhms, opto-isolated
Analog: minimum 10MOhms

Range

Digital Input - On: 5 to 40Vdc
Digital Input - Off: 0 to 2Vdc
Analog DC Voltage: 3 scales, ± 25.5 , $+51.1$, ± 255
Analog AC Voltage: 2 scales, 25.5, 255

Analog Current: 2 scales (optional), ± 25.5 Adc, 25.5Aac

Event Validation Times

Digital: .01 to 327.67 seconds, compatible with fixed rate flashing circuits
Analog: fast and slow filter settings

Analog Input Accuracy

Typical Vdc: $\pm 1\%$ full scale
Typical Vac: $\pm 1.5\%$ full scale
Typical Current: $\pm 2\%$ full scale

Analog Limit Values

Voltage

Separate high and low limits, in multiples of .1V or 1V

Current

Separate high and low limits, in multiples of .1A

Internal Temperature

Separate high and low limits, -67°F to 257°F

Memory

Type

Non-volatile, Event Records and Setup Database are stored in flash memory chips

Storage Longevity

Infinite with power off
Rated for 1 million write operations

Connectors

Digital and Analog Inputs

Detachable, screw-down, 6 or 8 terminals each, 12 to 22AWG

Terminal Port

DE-9 male, configured as DCE

Power

Detachable, screw-down, 4-position, 12 to 22AWG
Dual B and N terminals

Ethernet Port

RJ-45 female

Current Sensor

DE-9 female, used with CWR-CS

Indicators

LED: power, green

Internal Clock

Accuracy

Typical: ± 1 minute per month (20ppm)

Sync: Primary Unit synchronizes each Secondary Unit cloc every 10 seconds

Internal Clock (continued)

Resolution

Event Records are time stamped to nearest .01 seconds

Operation

Full calendar, auto-adjusted for leap year

Non-volatile with power off

Y2K compliant

Password Protection

Type: Restricted only, access to Event Record and Setup Database viewing only, limit 8 characters

Entire Setup Database is under control of the Primary Unit

Usage: applies only to Terminal Port

Ethernet Port

Type: 10/100 Base-T

Usage: normally connected to LAN via CAT-5 cable to Ethernet Switch

Speed: 100Mbps

Protocol: TCP/IP, Telnet

LED Indicators: Green - link established; Yellow - data activity

MICRO-AIDE reserves the right to make changes, at its sole discretion, to any specifications listed herein.

Terminal Port Cable

The following cable is included with every CWR-264XC.

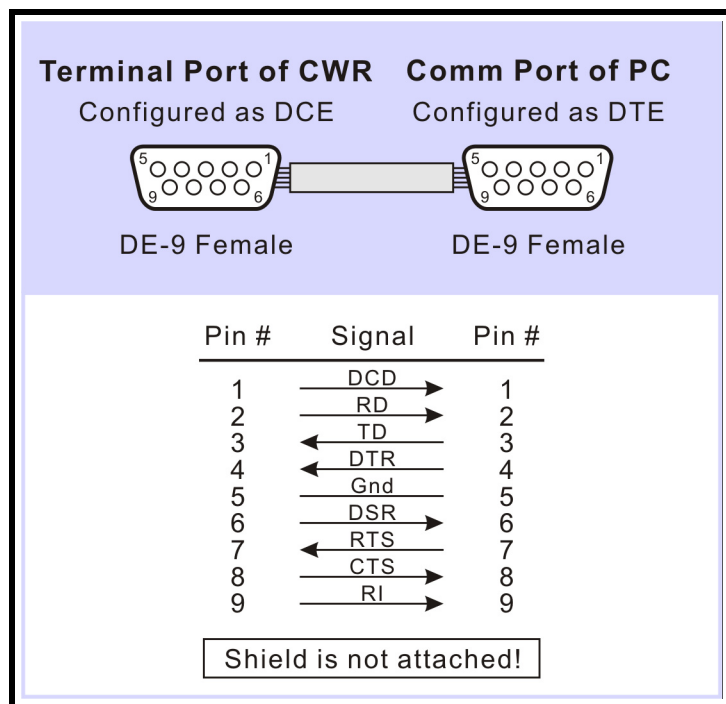

Figure 13 - Terminal Port Cable - Wiring Diagram