

## T24-Saf

Fast Strain Gauge Acquisition Module

User Manual  
[mantracourt.com](http://mantracourt.com)



mantracourt

Wireless Telemetry Range 2.4Ghz

<b>Introduction / Overview .....</b>	<b>2</b>
<b>Connections .....</b>	<b>2</b>
Power .....	2
Input Connections .....	2
Strain Gauge .....	2
<b>Configuration .....</b>	<b>3</b>
<b>Calibration .....</b>	<b>3</b>
Installation .....	3
T24 Toolkit .....	3
T24-BSu Base Station .....	3
T24 Toolkit .....	4
General Pages .....	4
Setup Base Station Communications .....	4
Home .....	5
Analyser .....	6
Data Provider Monitor .....	7
Information .....	8
Battery Life .....	9
Battery and Radio Levels .....	10
Battery and Radio Levels Advanced Settings .....	11
Channel and Encryption .....	12
Save and Restore .....	13
Data Provider Monitor .....	14
Advanced Settings .....	15
<b>Installation .....</b>	<b>16</b>
Overview .....	16
Power Supply / Battery .....	17
Considerations When Selecting Batteries .....	17
Battery Types .....	18
Power Supply Modules .....	18
Lithium Ion /Polymer Module T24-BC1 .....	18
Physical Connections .....	19
Specification .....	19
Suitable Batteries .....	19
Capacitor Module T24-BC2 .....	20
Mounting .....	21
Antenna .....	22
Internal Chip Antenna .....	22
External Antenna Option .....	22
External Antennas .....	23
Antenna Orientation .....	23
<b>Specifications .....</b>	<b>24</b>
General Radio .....	24
T24-SAf .....	24
<b>Approvals .....</b>	<b>24</b>
CE .....	24
FCC .....	25
Industry Canada .....	25
<b>OEM / Reseller Marking and Documentation Requirements .....</b>	<b>26</b>
FCC .....	26
IC .....	26
CE .....	26
<b>Declaration Of Conformity .....</b>	<b>27</b>
<b>Worldwide Regional Approvals .....</b>	<b>28</b>
Important Note .....	28
<b>Warranty .....</b>	<b>28</b>

## Introduction / Overview

For high speed applications the T24-SAf provides measurements at 2KHz with 200 packets per second containing 10 x 32 bit values representing nano volts/volt.

The T24-SAf will usually be used in conjunction with an analog output module or for supplying data to a computer via a base station.

Please note that these modules are not suitable for use with T24 handheld displays.

## Connections

You will require a 3 Volt dc supply for the acquisition module which may be 2 X AA alkaline batteries.

## Power

Attach power supply wiring to the module as shown below:

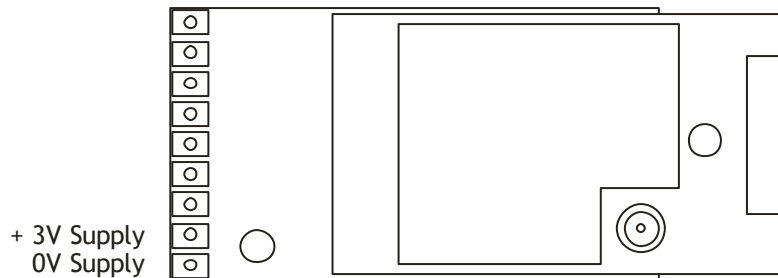

Connect to a 3 Volt power supply or batteries.

---

**WARNING: This module is not reverse polarity protected!**

**WARNING: The maximum voltage is 3.6V!**

---

## Input Connections

### Strain Gauge

Strain gauge connection is 4 wire as follows:

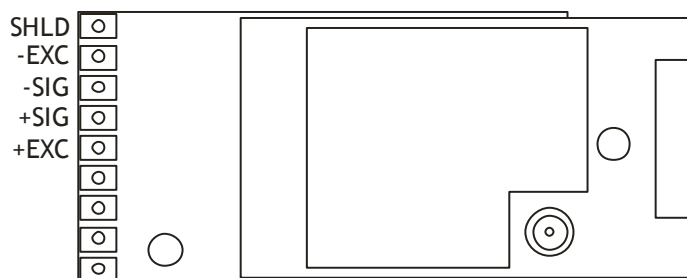

The resistance of the strain gauge can be between 85 and 5000 Ohms. The T24-SAf can support up to 4 350Ohm strain gauges bridges attached in parallel (At the expense of reduced battery life).

The cable lengths between the T24-SAf and the gauges should be kept below 3 meters and generally as short as possible.

As the measurement is 4 wire the longer the cable the more inaccurate the measurement from the factory mV/V calibration will be due to voltage drops in the cable.

The cable should be of good quality and shielded at either the T24-SAf SHLD point and should not be connected to the metal housing of the load cell.

The strain gauge measurement is bi-directional, i.e. tension & compression.

## **Configuration**

This section explains how to install software and configure the module. Please note that you will need the T24 Toolkit software and a T24-BS base station to allow your computer to communicate with T24 telemetry devices.

## **Calibration**

Please Note: The calibration feature is not available for the T24-SAf.

## **Installation**

### **T24 Toolkit**

To configure the devices we must use the **T24 Toolkit** software application. This can be downloaded from our web site or may be shipped with your products.

Install this on a PC or laptop.

Run setup.exe and follow the prompts to install the software.

### **T24-BSu Base Station**

If you have a USB version of the base station (T24-BSu) then you just need to plug this into a USB socket on your PC. If you are using an alternative base station then please refer to the appropriate manual.

## T24 Toolkit

The T24 Toolkit provides a means of simple configuration of the acquisition module along with useful tools to aid integration.

Run the T24 Toolkit software application.

### General Pages

#### Setup Base Station Communications

**T24 Toolkit**

### Settings

Select the connection type between the base station and the

**Interface**  
**USB** Select the interface between the computer and the base station.

**Port**  
**3** Select the COM port that the base station is connected to.

**Baudrate**  
**250000** Select the baudrate that matches the settings of the base station DIP switch.

**Base Station Address**  
**1** Each base station has an address settable by DIP switches. The address selected here must match the connected base station you wish to connect through.

#### Help

Configure the settings on this page to match the connected Base Station.

- First you need to determine whether the connection to your PC is Serial or USB.
- If it is Serial then you also need to know which serial port (COM port) it is connected to and the Baudrate of the Base Station.
- Next you need to know the Base Station Address. This can be set between 1 and 16 and should not be confused with the ID.
- When correctly setup click the HOME button to test communications and to continue.

App:1.0.0 | Drv COM:1.0.0 | Drv DLL:1.9.0

Select **USB** as the interface and select **1** as the Base Station Address.

In the toolkit all items that can be changed by the user are coloured orange.

To change a value just click on the relevant orange item. You will then be presented with a new dialog window allowing you to change the value.

This may use a slider, text box or list to allow your new value to be entered.

Click the Home button to attempt communications with the base station.

If no communications can be established the toolkit will remain on this page. You will need to check that the base station is powered and that it is connected to the converter correctly.



We now have successful communications with the base station so we can now pair with our device or we can select the Spectrum Analyser mode or Data Provider Monitor mode.

To connect to our device we will pair. This is achieved by power cycling the device. Pairing removes the need to know the radio settings of the device you are connecting to and also ensures that it is in a suitable state for configuration.

**Pairing Procedure**

- Remove power from the acquisition module.
- Click the Pair button on the toolkit.
- You now have 10 seconds to re-apply power to the acquisition module.

If you connect successfully the toolkit will change to the Information page.  
If the pairing fails try again.

---

**NOTE:** Pairing with the toolkit will **not** change the radio configuration settings of the connected device.

---

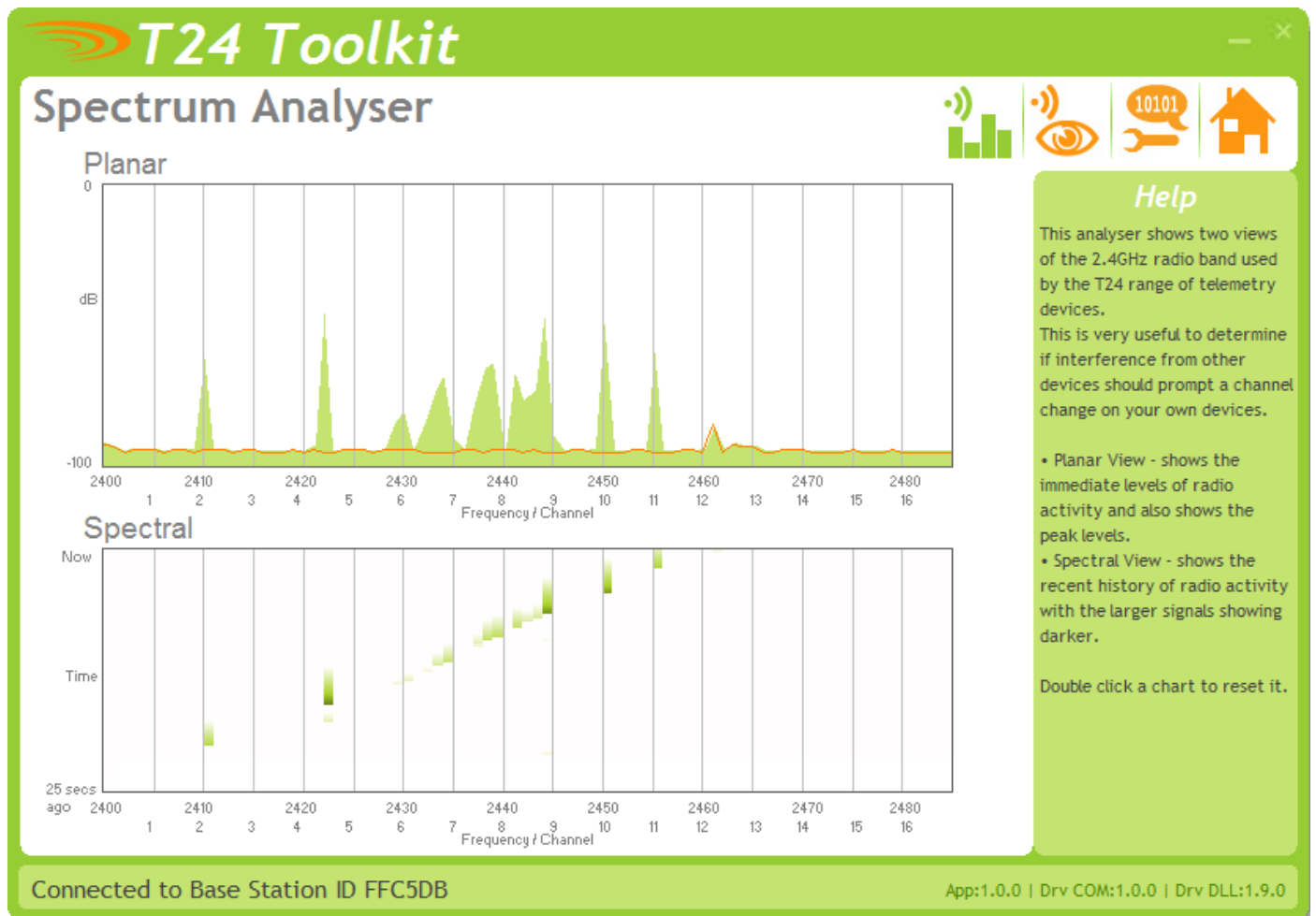

The analyser page is provided as a tool and will not normally be needed unless you plan to change channels and want to find the best channel to select, or to diagnose poor communications issues.

This page shows the radio signal levels detected across all the channels available to the T24 series of devices. Using this tool may help in detecting noisy areas and allow you to decide on which channels you may want to use.

The above charts show the traffic from a Wi-Fi network and it can be seen to be operating over channels 6 to 9 and it would be best (though not essential) to avoid using these channels.

## Data Provider Monitor

Data Tag	Total	Per sec	LQI	Value
C629	18	3	100	0.0160147
C623	58	10	100	0.0129487
C628	18	3	100	0.0218671
C62C	18	3	100	0.0152698
C627	17	3	100	0.0172869
C624	17	3	100	0.0130830

Select the devices you wish to log from the above list by checking them. Pressing the Start Logging button will allow you to select a filename to log the data to.

View Last Log Start Logging

Connected to Base Station ID FFC5DB App:1.0.0 | Drv COM:1.0.0 | Drv DLL:1.9.0

### Help

This page allows you to monitor Data Provider packets. Data Provider packets are what acquisition devices transmit periodically.

You have the option of logging these to a comma separated value (CSV) file.

### NOTE

*Prior to version 1.1.91 of the T24 Toolkit the value shown for a T24-SAf will look like random characters because the data packet from the T24-SAf contains 10 values not just the normal single value.*

*Version 1.1.91 and later will show the correct value but will only log at 200Hz.*

*To log at 2KHz please pair to the module and use the specific Data Provider Monitor page shown later in this manual.*

**T24 acquisition devices normally operate in low power mode and periodically transmit Data Provider packets**

**This page shows all detected Data Provider packets which may be useful for checking that a device is operational.**

NOTE: When the toolkit connects to a device to enable configuration it will usually inhibit the transmission of Data Provider packets.

The Start Logging button will ask for a filename and proceed to log the received data to a CSV file in the following format:

**Data Tag, Elapsed mS, Value**

The View Last Log button will launch the application associated with CSV files and open the last logged file.



## Information

**Information**

Fast Strain Acquisition Module

ID: FFC937  
Model: T24-SAf  
Firmware Version: 1.00  
Radio Module Firmware Version: 1.8  
Name: [redacted]

**Help**

Here you can view information about the device. You can also allocate a descriptive name to aid future identification.

Pressing F1 or double-clicking the module image will display the T24-SAf manual if it can be located.

Connected to T24-SAf of ID FFC937 on channel 6

App: 1.1.90 | Drv COM: 1.6 | Drv DLL: 2.6

Once successfully paired to a device this page is displayed. This page shows you information about the connected device.

### Items you can change:

**Name** You can enter a short description which may help you recognise this device in the future.

## Battery Life

The screenshot shows the 'T24 Toolkit' application window. The title bar reads 'T24 Toolkit'. Below the title bar is a navigation bar with several icons. The main content area is titled 'Battery Life' and contains a 'Battery Life Guide' section. This section has four input fields: 'Battery Type' (set to 'Custom'), 'Usable Capacity (Ah)' (set to '1.1'), 'Sensor Impedance (Ohms)' (set to '1000'), and 'Usage Per 24 Hour Period (Hours)' (set to '6'). Below these fields, the calculated result is displayed as 'Battery Life: 3 days and 8 hours'. To the right of the input fields is a 'Help' section with text explaining that the guide is only an indication of battery life and that many factors can affect it. At the bottom of the window, a status bar shows 'Connected to T24-SAf of ID FFC937 on channel 6' and 'App: 1.1.90 | Drv COM: 1.6 | Drv DLL: 2.6'.

This page gives guides on achievable battery life.

Note that the battery life calculator is assuming the best case scenario which is at 20°C and that the battery has a suitable low internal resistance or that a suitable capacitor is fitted across the battery. See battery details in the Installation section.

### Items you can change:

#### Battery Type

This is not a parameter of the device but information used by the battery life guide. You can choose from some preset batteries or choose custom to allow you to select your own battery capacity. See below. This will also offer to change the Battery Low Level if the level suitable for the chosen battery is not the level currently set.

#### Usable Capacity

This is not a parameter of the device but information used by the battery life guide. This is the capacity of the battery in Amp Hours and has a profound effect on battery life calculations. This capacity needs to be calculated from battery manufacturer's data sheets to take into account that we can only use batteries down to 2.1 Volts so in the case of twin AA cells this would be 1.05 Volts.

Generally the usable capacity will not be as high as that advertised by the battery manufacturer. Temperature and internal resistance of the battery are not taken into account in the guide.

#### Sensor Impedance

This is only available for certain acquisition modules. This is not a parameter of the device but information used by the battery life guide. Enter the resistance of the connected strain gauge in Ohms.

#### Usage Per 24 Hour Period

Enter the number of hours per 24 hour period that the T24-SAf will be turned on and communicating.

## Battery and Radio Levels

The screenshot shows the 'T24 Toolkit' software interface. The main window is titled 'LQI & Battery' and features a toolbar with icons for settings, signal strength, battery, and help. The interface is divided into three main sections: 'Signal Strength', 'Battery Voltage', and a 'Help' sidebar.

**Signal Strength**

**Local** Signal received at the Base Station  
LQI: 100

Link Quality Indicator - A summary indication of the quality of the radio link.

**Remote** Signal received at the acquisition module  
LQI: 100

**Battery Voltage**  
2.18V

Low Battery Level: 2.20

Advanced

Connected to T24-SAf of ID FFC937 on channel 6

App: 1.1.90 | Drv COM: 1.6 | Drv DLL: 2.6

Here you can see the voltage of the battery and the radio signal levels at the base station and the remote acquisition module. This simple view gives an LQI value which stands for Link Quality Indicator. This value will range from 0 to 100 and within this band you should still achieve communications. As the level drops towards zero communications may become intermittent but still achievable.

You can set the level at which the acquisition module reports a low battery. If the battery voltage is below the Low Battery Level the bar will be coloured orange.

### Items you can change:

Low Battery Level                      Click this item to set the battery low level.

Clicking the Advanced button will give more detailed information on the RSSI and CV levels of the received radio packets.

## Battery and Radio Levels Advanced Settings

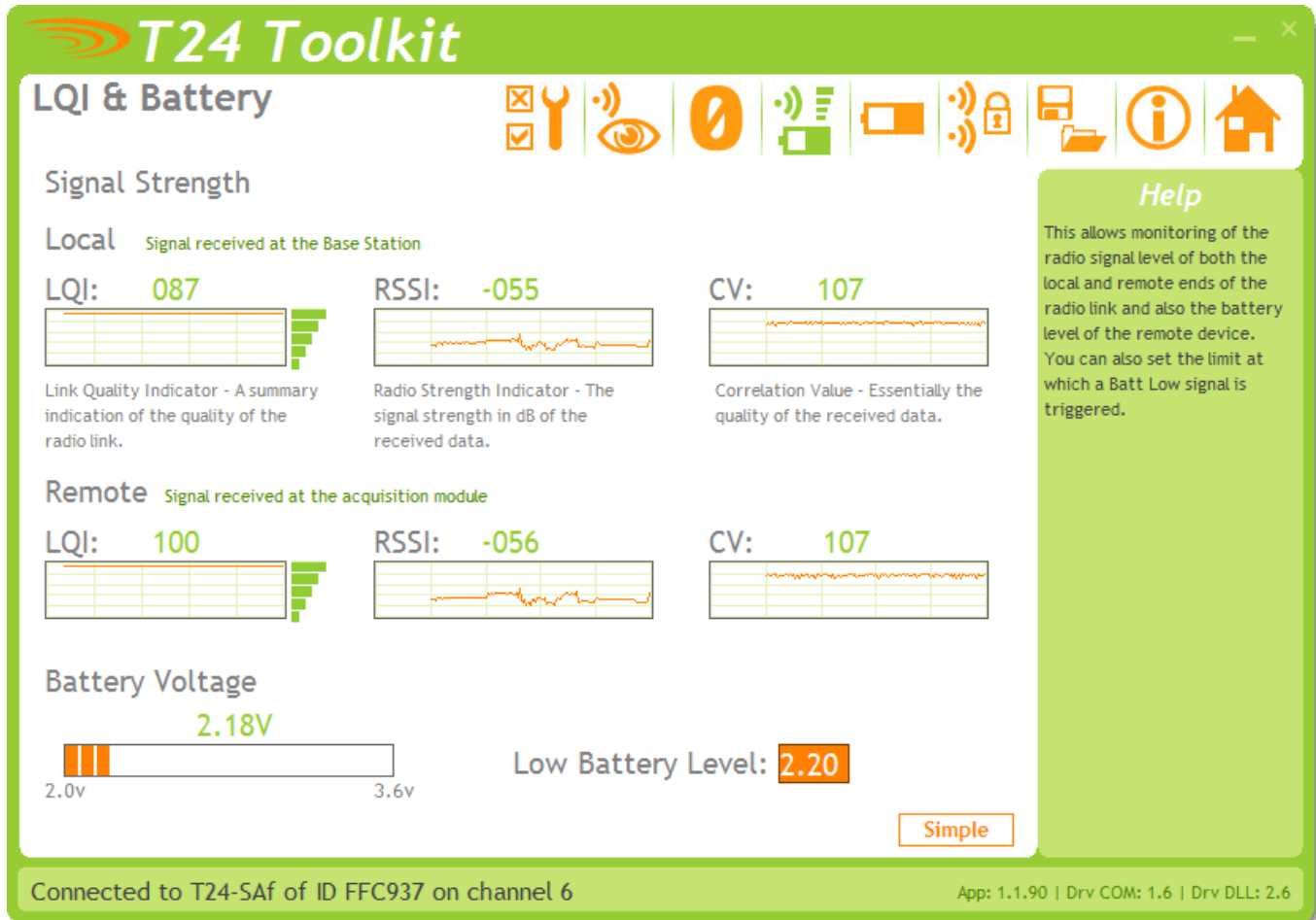

**LQI** value which stands for Link Quality Indicator. This value will range from 0 to 100 and within this band you should still achieve communications. As the level drops towards zero communications may become intermittent but still achievable.

**RSSI** is effectively the received dB level which will range from about -30 which is a good signal to -90 which is a weak signal.

**CV** is the correlation value and indicates how well the signal can be decoded. This ranges from 55 which is a poor quality signal and 110 which is an excellent signal.

## Channel and Encryption

**T24 Toolkit**  
Channel and Encryption

**Channel**  
16 You can select 1 of 16 channels

**Encryption Key**  
FFFFFFFFFFFFFFFFFFFFFFFFFFFFFFFFFFFFFFFF  
The encryption key is 32 hex characters long.  
Characters allowed are 1234567890ABCDEF

**Help**  
Here you can change the channel and encryption key for the connected device.  
  
NOTE: The device will need power cycling before these changes take effect.  
If you power cycle the device you will need to click the HOME button and pair the device again with this application.

NOTE: Changing the channel and key will not affect the device until it has been power cycled.  
If you have a handheld device and one or more acquisition devices and you want to change the channel and keys for all you could do either of the following:

- Connect this toolkit to each of the devices in turn and change the channel and key settings.
- Connect to just the handheld device and set the channel and key as required. Next using the pair function in the handheld connect to each acquisition device to change its settings to match those of the handheld.
- Connect to one device and change its channel and key as required. Click the Home button and then re-pair to that device. The base station will now match its settings to that device. Return to this page and click the Advanced button. From here you will be able to quickly change the settings of multiple devices to match the base station just by pairing with each one in turn.

Advanced

Connected to T24-SAf of ID FFC937 on channel 6  
App: 1.1.90 | Drv COM: 1.6 | Drv DLL: 2.6

Here you can change the channel and encryption key for the acquisition module device. Simply pair to the T24-SAf and change its channel and key.

Note that some devices such as the T24-AO1 analog output module will allow pairing to an acquisition module. When pairing it will alter the T24-SAf settings to match those of the analog output module.

NOTE: Early acquisition module do not yet utilise the encryption keys so these should be left at all zeros.

### Items you can change:

- Channel** Select a channel between 1 and 16. The default is channel 1. You can use the Spectrum Analyser mode to determine a good clean channel to use.  
NOTE: Channel 16 is used to negotiate pairing so avoid this channel if possible.
- Encryption Key** Only devices with identical encryption keys can communicate. You can isolate groups of devices on the same channel or just use the key to ensure the data cannot be read by somebody else.

## Save and Restore



Here you can save the device settings to a file on your PC so that they can be later loaded back into the same or different device.

### Items you can change:

- |                   |                                                                                                                                                                                                                                                                                     |
|-------------------|-------------------------------------------------------------------------------------------------------------------------------------------------------------------------------------------------------------------------------------------------------------------------------------|
| Save              | Click this button to open a file dialog window to allow you to select a filename and location to save the configuration file to. All configuration information including calibration data will be saved to the file. The file extension is <b>tcf</b> .                             |
| Restore           | Click this button to open a file dialog window to allow you to select a filename and location of a previously saved file to load into the connected device. All configuration information <b>including</b> calibration data will be overwritten. The file extension is <b>tcf</b> . |
| Advanced Settings | Click this button to enter the Advanced Settings Page. Here are settings which do not normally require changing.                                                                                                                                                                    |

## Data Provider Monitor

Because the data packet from this device does not just carry a single value this page provides an example of decoding the 10 values from each packet and displays them.

Trend

200/sec

Values nV/V

1	909	5	928	9	890
2	922	6	947	10	909
3	935	7	922		
4	897	8	941	Delta	227

Reset

The data packets arrive at a rate of 200 per second but this display only updates 3 times per second. If you select logging below the data will be logged to a CSV file at the rate at which it arrives.

Pause Continue Start Logging View Last Log

Connected to T24-SAf of ID FFC937 on channel 6 App: 1.1.90 | Drv COM: 1.6 | Drv DLL: 2.6

**Help**  
Provides a quick method of viewing the data provided by the module and optionally to log to a CSV file.  
NOTE: The display is only updated 3 times per second.

Because the standard data provider monitor does not decode correctly the multiple data packets from as T24-SAf this special page provides a trend chart and a view of all 10 readings contained in each packet. It also shows a delta value (Max - min) and allows you to log the data to a file.

### Items you can change:

- |               |                                                                                                                                                                                                                                                                                                                                                                                                                                                                                                           |
|---------------|-----------------------------------------------------------------------------------------------------------------------------------------------------------------------------------------------------------------------------------------------------------------------------------------------------------------------------------------------------------------------------------------------------------------------------------------------------------------------------------------------------------|
| Reset         | Clicking here will reset the Delta display to zero.                                                                                                                                                                                                                                                                                                                                                                                                                                                       |
| Pause         | Stop the module transmitting data.                                                                                                                                                                                                                                                                                                                                                                                                                                                                        |
| Continue      | Continue with data transmission.                                                                                                                                                                                                                                                                                                                                                                                                                                                                          |
| Start Logging | Allows you to select a filename and starts to log the data to the selected file. The format of the file is CSV and the columns are:<br><br><b>Elapsed,Value &lt;carriage Return&gt;</b><br><br>Where<br><br><b>Elapsed</b> is a timestamp counter provided by the T24-SAf. Each unit represents 500uS and the number will reset to zero every 32.768 seconds. This timestamp aids in spotting lapses in data and allows graphing data even with dropped packets.<br><br><b>Value</b> is the value logged. |
| View Last Log | The same button is used to stop the logging. Once logging has stopped clicking this will open the log file in the program associated with the .csv file extension.                                                                                                                                                                                                                                                                                                                                        |

## Advanced Settings



You should not normally need to change these settings.

### Items you can change:

#### Sleep Delay

Here you can enter a delay in seconds after which the acquisition module will return to deep sleep if no Keep Awake message is heard from another T24 module such as an analog output module. The default is 60 seconds.

#### Data Tag

The data transmitted by the acquisition module is marked with a Data Tag which is a 2 byte hexadecimal code. By default this is set to the last 2 bytes of the device ID (or to put it another way, the last 4 characters of the device ID). If by some chance you had two acquisition module devices that would be working on the same channel and had the same last 4 characters in their ID (1 in 65,535 chances) you may want to change the data Tag of one of the devices and perform pairing again with the associated T24 module.

#### Shunt Cal

Allows turning on or off the application of a shunt cal resistor to the bridge input. You must remember to turn this off before exiting the Toolkit software.

#### nV/V

Shows the output value so the effect of the Shunt Cal can be seen.



## Installation

### Overview

Radio performance at microwave wavelengths is very dependent upon the operating environment; any structure within the operating region of the radios will give rise to three effects:

**Obscuration.** Obscuration will result in reduced range and occurs when an obstruction masks the line-of-sight between radios.

**Aberrations to the horizontal and vertical space patterns.** Distortion of these patterns may occur if structures or objects are placed in the near or intermediate field of the antenna. The effect will be to distort the coverage patterns, adversely affecting range and link quality.

**Reflection.** Any object placed in line-of-sight of the transmit antenna will result in signals arriving at the receiver by an indirect path. Degradation of performance due to reflection (multipath effects) appears as reduced range or poor link quality.

Any of the above will cause poor RSSI figures, an increase in the packet loss rate and in extreme cases complete loss of signal. Fortunately, if consideration is given to these effects at the integration stage then a good quality link will be obtained.

#### **Guidelines for product design:**

When selecting materials for product enclosures, preference should be given to fibreglass, light coloured ABS or Polypropylene; at the wavelength of 2.4GHz radio other materials will adversely affect the signal by attenuation, refraction or change in polarisation.

If the application demands that the radio is fitted inside a metal enclosure then ensure that the specified clearances are maintained around the antenna and design in a fibreglass RF window at least as large as the clearance dimensions but ideally as large as possible.

RAD24i radios fitted inside a product should be oriented so that the chip antenna will be vertical when the product is in its normal operating position.

#### **Guidelines for installation:**

When planning installations ensure that line-of-sight between nodes is maintained and that objects or structures are kept at least one metre away from antennae wherever possible.

To avoid poor link quality between a RAD24i radio and a handheld device ensure that the RAD24i is mounted so that the chip antenna is vertical. Improvement may also be obtained by altering the height above ground of the RAD24i; a small increase or reduction in antenna elevation will often improve reception.

Range underwater is only a decimetre or so depending on packet rate. Best performance underwater is obtained by using low packet rates and immersing water-proofed antennae rather than water-tight enclosures containing the antennae.

## Power Supply / Battery

The acquisition module operates from 2.1 to 3.6 Volts dc so can be supplied from a variety of cells.

---

**WARNING: It is important to note that the acquisition module is NOT reverse polarity protected!**

**WARNING: The maximum voltage is 3.6V!**

---

### Considerations When Selecting Batteries

#### Re-chargeable or replacement

This really depends on the application. Some applications where expected battery life with alkaline batteries will be many years would probably not warrant the use of re-chargeable batteries. Re-chargeable batteries have implementation issues such as how to connect to the charger, how to seal this connection if required, can the batteries be re-charged at a convenient point in the operation of the device I.E between shifts and does the voltage, when charging, exceed the maximum supply voltage of the acquisition module if so the inline charging module will need to be fitted.

#### Required battery life

Driven by the application and mainly dependent on measurement rate and sample time. The operation would normally require that the acquisition module is used in Low Power Mode to maximise battery life.

#### Size of

Choosing a battery will be influenced by how much space is available and what battery life is required, generally the bigger the battery the longer it will last.

#### Operating temperature range

A batteries useable capacity is influenced by its operating temperature. Generally, the lower the temperature the lower their ability to provide charge. Beware of the batteries specified operating range when considering a particular battery technology.

#### Self discharge.

Batteries are chemical devices and have a shelf life which needs to be considered in application where long battery life is required. Typically an Alkaline has a battery life of 5 years.

#### Internal Resistance of battery

Low internal resistance is important, the higher the resistance the less useful life of the battery is available. This is due to voltage drops caused during the high current phase of the measurement cycle. In the case of a T24-SAf strain gauge input module 300mA required for 250uS. Batteries with an internal resistance of less than 150mOhm will not require the additional inline capacitor module.

#### Connections to battery

For the same reasons internal resistance must be low it is important to keep any voltage drops from the battery to the acquisition module as low as possible too. Care must be taken in selecting the connection method between batteries and acquisition module. For example cables should be kept as short and thick as possible.

#### Environmental

Other considerations when selecting a connection method to the Batteries is the effect of vibration. A standard battery holder is a poor choice in applications when the device can be subject to vibration. This is due to the interruption of supply from the battery to the acquisition module caused when the spring arrangement holding the battery to the terminal of the holder is defeated.

Corrosion of terminals must also be considered as this will also introduce resistance into the supply connections. This could be overcome by ensuring the enclosure is sealed.

#### Optimising battery life

Battery life can be optimised by considering the following.

- Use of low power mode.
- Transmission interval.
- Required Measurement resolution (Sample time).
- Sleep / Wake configuration
- Auto-Sleep duration.

## Battery Types

Battery Type	Notes
Alkaline Zn-MnO <sub>2</sub>	Pairs of alkaline 1.5V cells are the most common. Use D cells for maximum life and AA cells where space is restricted. Example: Varta 4014 (D), Varta 4006 (AA) <b>Recommend T24-BC2 module</b> to maximise usable capacity.
Nickel Metal Hydride NiMh	Most cells are 1.2V so two in series gives 2.4 Volts. These can match alkaline batteries in capacity but as the charged voltage is lower they do not match the usable capacity. These batteries self discharge at a faster rate than alkalines. If charging these cells in circuit precautions must be taken to ensure that the maximum voltage on the acquisition module is not exceeded. Example: GP 270AAHC (AA) <b>Recommend T24-BC2 module</b> to maximise usable capacity.
Nickel Cadmium NiCad	Most cells are 1.2V so two in series gives 2.4 Volts. Three in series can be used to give 3.6 Volts. These do not have the usable capacity of an alkaline battery. These are generally only useful if they are to be charged on a regular basis. If charging these cells in circuit precautions must be taken to ensure that the maximum voltage on the acquisition module is not exceeded. Example: <b>Recommend T24-BC2 module</b> to maximise usable capacity.
Lithium Primary 3.6V Li-SOCl <sub>2</sub>	Lithium cells can be used but note that the maximum voltage is 3.6 Volts. Select a cell with low internal resistance. Example: Saft LS17500 (A), Saft LSH20 (D) <b>Recommend T24-BC1 module</b> as these cells usually have a high internal resistance.
Lithium Iron Disulphide Li-FeS <sub>2</sub>	These can be found at 1.5 Volts and can therefore be a direct replacement for Alkaline cells. The low internal resistance and high capacity make these batteries an ideal choice. Example: Energizer L91
Lithium Ion and Lithium Polymer LiON, LiPo	These generally start at 3.7V and exceed the maximum allowable voltage. These are usable if a regulator and charging circuit can be installed between the acquisition module and the battery. Care must be taken here that the regulator does not draw too much current when idle so that the low power modes are not compromised. <b>Recommend T24-BC1 module.</b>

## Power Supply Modules

### Lithium Ion /Polymer Module T24-BC1

The T24-BC1 is a battery charger and power supply suitable for the T24 range of 3V acquisition modules. The T24 Battery Charger is designed to supply a constant 3.3V from a Li-ion Battery while also charging the battery from an input voltage. The unit comes pre-configured to provide a charging current of 466mA suitable for VARTA LIP653450. This module also supports additional batteries providing a charge current of 133mA via the removal of the leaded resistor (non surface mount).

## Physical Connections

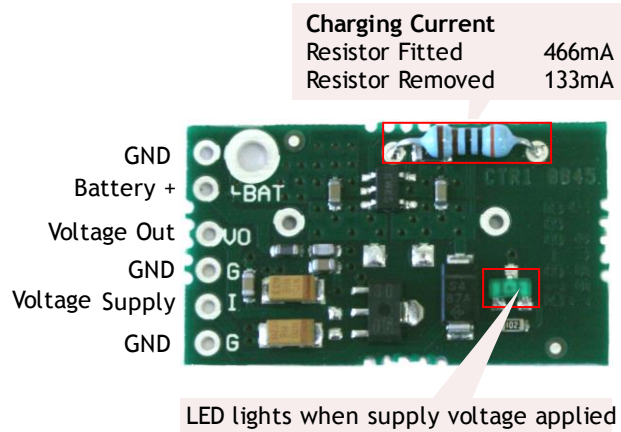

## Specification

Parameter	Min	Typ	Max	Units
Supply Voltage	4.1	5	6	V
Regulated Voltage Output	-	3.3	-	V
Battery positive connection	-	3.7	-	V
Maximum Cable Length	-	-	150 *	mm
Quiescent Current	-	1.7	-	$\mu$ A

\* 07/02 gauge wire attached to maximum load i.e. T24-SAf with four 350 Ohm strain gauges  
 Note LED will only be lit when an input voltage is applied

## Suitable Batteries

### VARTA LIP653450

- Rated Capacity: 1100mAh
- Dimensions: 35 x 54 x 7 (mm)
- Weight: 20g
- Charge Time : 3 Hours @ 466mA
- Battery life = 3.3 days\*



### VARTA LIC18650

- Rated Capacity: 2200mAh
- Dimensions: 18.25 Diameter 65mm Height
- Weight: 46g
- Charge Time : 4.5 Hours @ 466mA
- Battery life = 6.5 days\*



### UBC 581730

- Rated Capacity: 250mAh
- Dimensions: 18 x 31.5 x 5.8 (mm)
- Weight: 6.5g
- Charge Time : 2 Hours @ 133mA
- Battery life = 18 hours \*

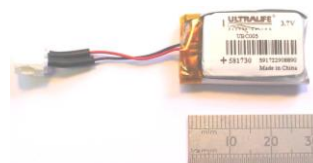

\* Note: Battery life is calculated with a T24-SAf running for 2 hours out of every 8 hours, to a 1k $\Omega$  bridge.

### ***Capacitor Module T24-BC2***

This is used for batteries which have an internal resistance of greater than 150mOhms overcoming voltage drops during high current phases of the low power mode cycle.

This problem becomes apparent when attempting to communicate with high peak current acquisition modules such as a T24-SAf using the T24 Toolkit or power cycling when the battery is near the end of its life. In normal operation (Low power mode) with an analog output module or the T24-SAf is connected to an uninterrupted battery this module is generally not required.

Using lower impedance strain gauges (or multiple parallel strain gauges) exacerbates this problem.

Consult Sales for details. Alternatively fit an electrolytic capacitor across battery of 2000uF or greater. This capacitor should be of low ESR (< 70mOhms).

## Mounting

### Mechanical size

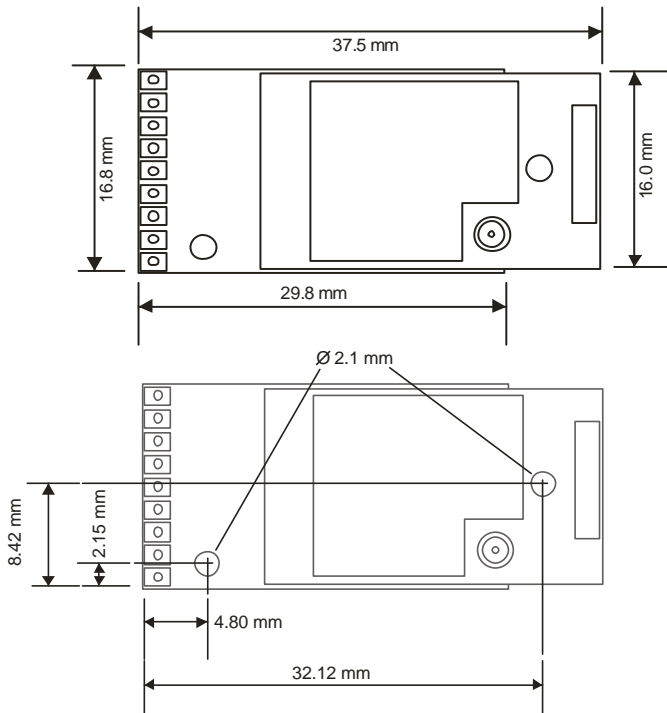

There are two holes available for mounting. The one nearest the connection pads can accept an M2 screw or American equivalent #0-80. Important Note: DO NOT USE #2 screw size. Note that the mounting hole is connected directly to the Battery ground of the acquisition module. The mounting hole near the chip antenna cannot accept metal mounting hardware.

The connection holes are on a 1.9mm pitch and are a diameter of 1mm.

## Antenna

### Internal Chip Antenna

There must be no metal objects within 7mm of the antennas long edge and 20mm from the short edges. See diagram below

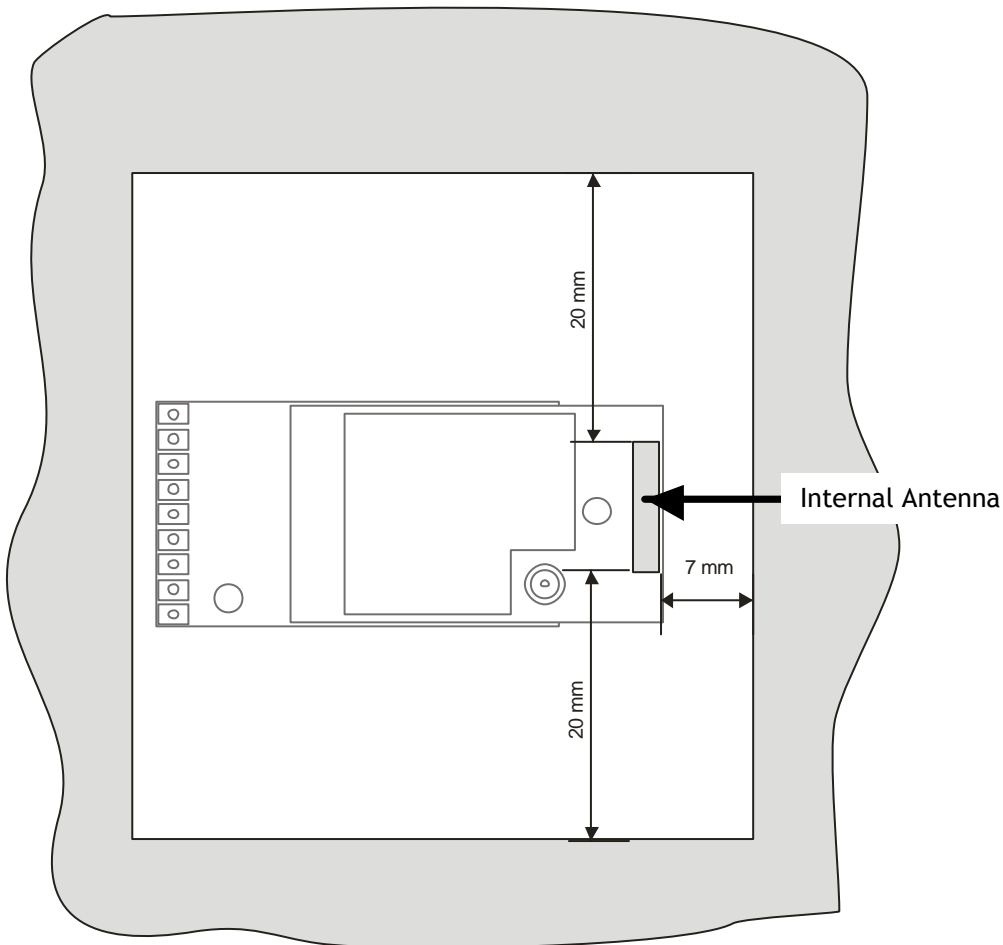

### External Antenna Option

Use of a T24 external antenna requires a T24 acquisition module with a UFL connector stud in place of the on-pcb antenna.

T24 acquisition modules fitted with a UFL stud have a suffix 'e' to the part number e.g. T24-SAe

Note: The suffix 'e' is omitted where the T24 acquisition module is fitted inside a T24-ACM or T24-ACMi enclosure e.g. T24-ACM-SA, T24-ACMi SA

## External Antennas

The external antennas come in two styles.

The flat PCB antenna can be mounted inside a plastic housing or to the outside of a metal housing. The PCB requires 3mm Clearance on all edges, this also applies to the RF window.

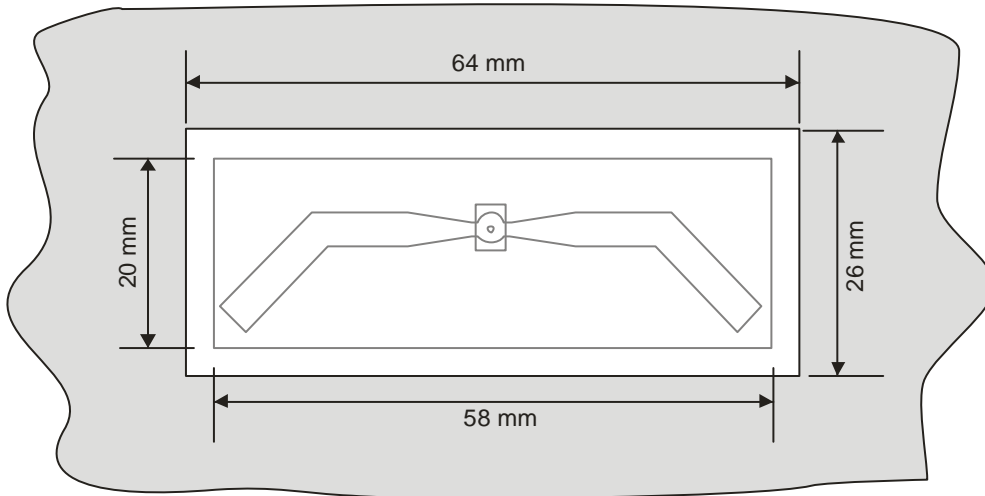

The bulkhead mounting antenna can be used with metal or plastic housings. Care must be taken when mounting the Antenna to ensure the installation does not become directional.

## Antenna Orientation

For the maximum range the acquisition module and any other modules should be orientated as shown.

The sensitivity to the radio transmission will be reduced if the acquisition module is oriented in a vertical or portrait position if a handheld is used because the handheld can only be used in one orientation.

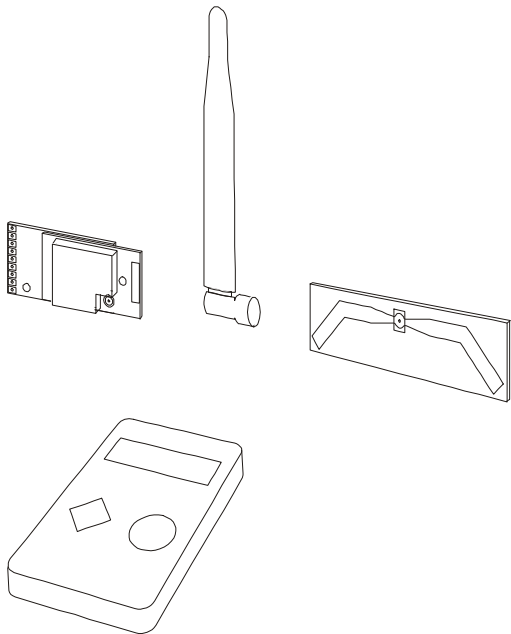



## Specifications

### General Radio

	Min	Typical	Max	Units
License		License Exempt		
Modulation method		MS (QPSK)		
Radio type		Transceiver (2 way)		
Data rate		250		K bits/sec
Radio Frequency	2.4000		2.4835	GHz
Power		1		mw
Range RAD24i (Integrated antenna)			100 (325)	Metres (feet) *
Range RAD24e (External antenna)			200 (650)	Metres (feet) *
Channels (DSSS)		16		

\* Maximum range achieved in open field site at a height of 3 metres above ground.

### T24-SAf

Specification with 1000R bridge, 2.5mV/V, at 3V supply at 25°C

Measurement	Min	Typical	Max	Units
Strain Gauge Excitation System	4 Wire			
Strain Gauge Excitation Voltage	4.5	5	5.25	V DC
Strain Gauge Drive Capability	85	-	5000	Ohms
Maximum Gauge Sensitivity (FR)			3.2	+/-mV/V
Offset Temperature Stability		1	4	ppm/C
Gain Temperature Stability		3	5	ppm/C
Offset Stability with Time		20	80	ppm of FR (1)
Gain Stability with Time			30	ppm of FR (2)
Non Linearity before Linearization		5	25	ppm of FR
Internal Resolution		16,000,000/ 24		Resolution/Bits

Noise free resolution is 8000/13 Bits for a 10 second sample period

1. From original offset at any time.
2. First year.

Electrical	Min	Typical	Max	Units
Power Supply voltage	2.1	3.0	3.6	V DC
Power Supply ripple			50	mV AC pk-pk

Power Supply current	Min	Typical	Max	Units
Normal Mode (1K Bridge)		60	65	mA
Standby / Low power mode		5	20	uA

Environmental	Min	Typical	Max	Units
Operating temperature range	-40		+85	°C
Storage temperature	-40		+85	°C
Humidity	0		95	%RH

Physical	
PCB Dimensions	17 x 37.5 x 6.5mm

### Approvals

CE



Complies with EMC directive. 2004/108/EC

The Radio Equipment and Telecommunications Terminal Equipment (R&TTE) Directive,

1999/5/EC,

### European Community, Switzerland, Norway, Iceland, and Liechtenstein

- English: This equipment is in compliance with the essential requirements and other relevant provisions of Directive 1999/5/EC.
- Deutsch: Dieses Gerät entspricht den grundlegenden Anforderungen und den weiteren entsprechenden Vorgaben der Richtlinie 1999/5/EU.
- Dansk: Dette udstyr er i overensstemmelse med de væsentlige krav og andre relevante bestemmelser i Directiv 1999/5/EF.
- Español: Este equipo cumple con los requisitos esenciales así como con otras disposiciones de la Directiva 1999/5/EC.
- Français: Cet appareil est conforme aux exigences essentielles et aux autres dispositions pertinentes de la Directive 1999/5/EC.
- Íslenska: Þessi búnaður samrýmist lögboðnum kröfum og öðrum ákvæðum tilskipunar 1999/5/ESB.
- Italiano: Questo apparato é conforme ai requisiti essenziali ed agli altri principi sanciti dalla Direttiva 1999/5/EC.
- Nederlands: Deze apparatuur voldoet aan de belangrijkste eisen en andere voorzieningen van richtlijn 1999/5/EC.
- Norsk: Dette utstyret er i samsvar med de grunnleggende krav og andre relevante bestemmelser i EU-directiv 1999/5/EC.
- Português: Este equipamento satisfaz os requisitos essenciais e outras provisões da Directiva 1999/5/EC.
- Suomalainen: Tämä laite täyttää direktiivin 1999/5/EY oleelliset vaatimukset ja on siinä asetettujen muidenkin ehtojen mukainen.
- Svenska: Denna utrustning är i överensstämmelse med de väsentliga kraven och andra relevanta bestämmelser i Direktiv 1999/5/EC.

This equipment is in compliance with the essential requirements and other relevant provisions of Directive 1999/5/EC.

**FCC**



Family: RAD24

Models: i and e for internal and external antenna variants. For antenna T24-ANTA and T24-ANTB

FCC ID: VHARAD24

This device complies with Part 15c of the FCC Rules. Operation is subject to the following two conditions: (1) this device may not cause harmful interference, and (2) this device must accept any interference received, including interference that may cause undesired operation.

**CAUTION:** If the device is changed or modified without permission from Mantracourt Electronics Ltd, the user may void his or her authority to operate the equipment.

**Industry Canada**



Industry Industrie  
Canada Canada

Models: i and e for internal and external antenna variants. For antenna T24-ANTA and T24-ANTB

IC: 7224A-RAD24

This apparatus complies with RSS-210 - Low-power Licence-exempt Radiocommunication Devices (All Frequency Bands): Category I Equipment RSS.

## OEM / Reseller Marking and Documentation Requirements

### FCC

The Original Equipment Manufacturer (OEM) must ensure that FCC labelling requirements are met. This includes a clearly visible label on the outside of the final product enclosure that displays the contents as shown:

Contains FCC ID:VHARAD24

This device complies with Part 15 of the FCC Rules. Operation is subject to the following two conditions:

- (1) this device may not cause harmful interference and
- (2) this device must accept any interference received, including interference that may cause undesired operation.

The acquisition modules have been tested with T24-ANTA and T24-ANTB. When integrated in OEM products, fixed antennas require installation preventing end-users from replacing them with non-approved antennas. Antennas other than T24-ANTA and T24-ANTB must be tested to comply with FCC Section 15.203 (unique antenna connectors) and Section 15.247 (emissions).

Acquisition modules have been certified by the FCC for use with other products without any further certification (as per FCC section 2.1091). Changes or modifications not expressly approved by Mantracourt could void the user's authority to operate the equipment.

In order to fulfil the certification requirements, the OEM must comply with FCC regulations:

1. The system integrator must ensure that the text on the external label provided with this device is placed on the outside of the final product.
2. The acquisition modules with external antennas may be used only with Approved Antennas that have been tested by mantracourt.

### IC

Labelling requirements for Industry Canada are similar to those of the FCC. A clearly visible label on the outside of the final product enclosure must display the following text:

Contains Model RAD24 Radio (2.4 GHz), IC:7224A-RAD24

Integrator is responsible for its product to comply with RSS-210 - Low-power Licence-exempt Radiocommunication Devices (All Frequency Bands): Category I Equipment RSS.

### CE

The T24 series has been certified for several European countries.

If the acquisition module is incorporated into a product, the manufacturer must ensure compliance of the final product to the European harmonized EMC and low-voltage/safety standards. A Declaration of Conformity must be issued for each of these standards and kept on file as described in Annex II of the R&TTE Directive.

Furthermore, the manufacturer must maintain a copy of the T24 device user manual documentation and ensure the final product does not exceed the specified power ratings, antenna specifications, and/or installation requirements as specified in the user manual. If any of these specifications are exceeded in the final product, a submission must be made to a notified body for compliance testing to all required standards.

#### OEM Labelling Requirements

The 'CE' marking must be affixed to a visible location on the OEM product.



The CE mark shall consist of the initials "CE" taking the following form:

- If the CE marking is reduced or enlarged, the proportions given in the above graduated drawing must be respected.
- The CE marking must have a height of at least 5mm except where this is not possible on account of the nature of the apparatus.
- The CE marking must be affixed visibly, legibly, and indelibly.

## Declaration Of Conformity

We, Mantracourt Electronics Limited  
The Drive  
Farringdon  
Exeter  
Devon EX5 2JB

declare under our sole responsibility that our products in the **T24 Radio Telemetry Product Range** to which this declaration relates are in conformity with the appropriate standard EN 300 328 following the provisions of the Radio and Telecommunications Terminal Equipment Directive **1999/5/EC**, FCC CFR Title 47 part 15c BS EN 61000-4-2 and BS EN 61000-4-3 following the provisions of the EMC Directive **2004/108/EC** and Low Voltage Directive **2006/95/EC**.

December 2007



Brett James  
Development Manager  
Mantracourt Electronics Limited.

FCC ID:VHARAD24



## Worldwide Regional Approvals

Region	Product Conforms To
Europe	CE
USA	FCC
Canada	IC
Australia	To Be Determined
China	To Be Determined
Japan	To Be Determined

### Important Note

Mantracourt does not list the entire set of standards that must be met for each country. Mantracourt customers assume full responsibility for learning and meeting the required guidelines for each country in their distribution market. For more information relating to European compliance of an OEM product incorporating the T24 range of modules, contact Mantracourt, or refer to the following web site: [www.ero.dk](http://www.ero.dk)

### Warranty

All Telemetry products from Mantracourt Electronics Ltd., ('Mantracourt') are warranted against defective material and workmanship for a period of (1) one year from the date of dispatch.

If the 'Mantracourt' product you purchase appears to have a defect in material or workmanship or fails during normal use within the period, please contact your Distributor, who will assist you in resolving the problem. If it is necessary to return the product to 'Mantracourt' please include a note stating name, company, address, phone number and a detailed description of the problem. Also, please indicate if it is a warranty repair.

The sender is responsible for shipping charges, freight insurance and proper packaging to prevent breakage in transit.

'Mantracourt' warranty does not apply to defects resulting from action of the buyer such as mishandling, improper interfacing, operation outside of design limits, improper repair or unauthorised modification.

No other warranties are expressed or implied. 'Mantracourt' specifically disclaims any implied warranties of merchantability or fitness for a specific purpose. The remedies outlined above are the buyer's only remedies. 'Mantracourt' will not be liable for direct, indirect, special, incidental or consequential damages whether based on the contract, tort or other legal theory.

Any corrective maintenance required after the warranty period should be performed by 'Mantracourt' approved personnel only.



In the interests of continued product development, Mantracourt Electronics Limited reserves the right to alter product specifications without prior notice.

Code No. 517-922

Issue 1.4

27.10.14

## Distribuidor

**Brasil e América do Sul**

### CONTATO

**Endereço**

Rua Sete de Setembro, 2671 - Centro  
13560-181 - São Carlos - SP - Brasil

**Telefone**

+ 55 (16) 3371-0112

**Fax**

+ 55 (16) 3372-7800

**Internet**

[www.metrolog.net](http://www.metrolog.net)  
[metrolog@metrolog.net](mailto:metrolog@metrolog.net)

