



#### CONTACT DETAILS

#### Leatt® Corporation

No 50, Kiepersol Crescent, Atlas Gardens, Contermanskloof,  
Durbanville, 7550, Cape Town, South Africa

Tel: +27 21 557 7257 • Fax: +27 21 557 7381

Email: [info@leatt-brace.com](mailto:info@leatt-brace.com) • Website: [www.leatt.com](http://www.leatt.com)

#### Postal Address:

Suite 109, Private Bag X3, Bloubergrant,  
7443, South Africa



**GPX Adventure**  
**USER MANUAL**



A percentage of your Leatt-Brace® purchase price is donated to the Wings For Life spacersal cord research foundation.  
[www.wingsforlife.com](http://www.wingsforlife.com)

## ! WARNING

Motor Sports and racing can be dangerous. Participation in these activities can result in severe brain, head and neck injuries which may result in paralysis or death. Although the Leatt-Brace® is designed to help reduce the risk of such injuries, there is no guarantee that any injury will be prevented by the use of this or any other safety equipment. Read all instructions prior to use. Before putting on your Leatt-Brace® each time, please review and comply with the following cautions and instructions below.

- ! The Leatt-Brace® cannot protect against all possible impacts and/or injuries. Although the Leatt-Brace® is designed to help reduce the risk of such injuries, there is no guarantee that any injury will be prevented by the use of this equipment. Perform any bicycling sport activity with caution and use/wear appropriate safety equipment.
- ! For maximum performance, the Leatt-Brace® must be properly fitted and attached according to the instructions in the user manual. It is recommended that this product be used only in conjunction with a helmet with a permanent fixed chin part (e.g full-face helmet, motorcross / DH helmet, DO NOT USE WITH A JET HELMET). Use at your own risk.
- ! For maximum performance, the Leatt-Brace® must be inspected prior to each use. **STOP** using the Leatt-Brace® if any components show signs of damage or are worn, cracked, and/or deformed, or if the inside padding is deteriorated. **Leatt® Corporation recommends that the Leatt-Brace® be replaced every two (2) years under normal racing conditions.**
- ! Should you experience a collision or if the Leatt-Brace® or any component shows any signs of damage, cracking, deformity and/or the inside padding is deteriorating, return the Leatt-Brace® to the seller for inspection or destroy and replace the Leatt-Brace®.
- ! Common substances applied to this brace (solvent, cleaners, hair tonics, etc.) can cause damage that may be invisible to the user and compromise the effectiveness/safety of the Leatt-Brace®. Wash only with gentle soap or detergent in cold water, rinse in cold water and dry with a soft cloth.
- ! Do not drill holes, paint, cut, heat, bend, or make any other modifications to the Leatt-Brace® unless authorized in advance by the Seller. Doing so may compromise the effectiveness/safety of the Leatt-Brace®.
- ! The brace has been tested using various static and dynamic tests, but has not been tested on riders under race conditions for instrumented impact assessment; this product is of a new design.
- ! The brace has been tested on a wide range of users and bicycle types and should fit you and your bicycle, if not, minor adjustments may be required for proper fit. Failure to properly adjust the brace before use may compromise rider safety and brace effectiveness.
- ! Always attach your helmet correctly according to seller's guidelines. Ensure that all of your safety equipment has not passed beyond its recommended life span. Travel/race with safety as your primary principle.

If you have any questions regarding this product or its proper use, please contact Leatt® Corporation at:

Leatt® Corporation RSA  
No 50, Kiepersol Crescent, Atlas Gardens, Durbanville, Contermanskloof, 7550, Cape Town, RSA  
Tel: +27 (0) 21 557 7257; Fax: +27 (0) 21 557 7381

Leatt® Corporation USA  
26320 Diamond Place, Unit 130, Santa Clarita, California 91350  
Tel: 800 691 3314; Fax: 661 295 6888  
Email: info@leatt.com

Copyright © 2012, Leatt® Corporation

### WARRANTY DISCLAIMER

YOUR LEATT-BRACE® IS WARRANTED TO BE FREE OF DEFECTS IN MATERIALS AND MANUFACTURING FOR ONE YEAR FROM THE DATE OF PURCHASE. CRASH DAMAGE, NEGLIGENCE, ABUSE OR ALTERATION OF YOUR BRACE IS NOT COVERED UNDER THIS WARRANTY. SEVERAL PARTS OF THE LEATT-BRACE ARE DESIGNED TO FRACTURE AS THEY HELP PROTECT YOU IN CERTAIN RIDING SCENARIOS. THESE PARTS ARE REPLACEABLE AND OFFERED FOR SALE. IF YOU BELIEVE YOU HAVE A WARRANTY CLAIM, TAKE THE BRACE BACK TO THE RETAILER YOU BOUGHT IT FROM. TO ACTIVATE YOUR WARRANTY PLEASE GO TO THE WWW.LEATT.COM AND FILL OUT THE WARRANTY REGISTRATION FORM OR EMAIL WARRANTY@LEATT.COM.

## Leatt-Brace® GPX Adventure III Table of contents

- GPX Adventure III Exploded View ..... Page 03 - 04
- Test specifications ..... Page 04
- User manual introduction ..... Page 05
- Leatt-Brace® sizing chart ..... Page 07 - 08
- Brace fitment
  - Leatt-Brace® fitment - step 1 ..... Page 09
  - Adjustment and fitting with spacers ..... Page 09 - 10
  - Strut and thoracic assembly - step 2 ..... Page 11 - 12
  - Opening and Closing the Brace ..... Page 12
  - Padding inserts ..... Page 13
  - Torque settings for screws ..... Page 13
- Padding Fitment ..... Page 14
- Chest strap ..... Page 14
- Fitting the GPX Adventure III with body armour ..... Page 15
- Looking after your Leatt-Brace® ..... Page 16
- Indemnity and warranty disclaimer ..... Page 17

**GPX Adventure III**

### GPX Adventure III exploded view

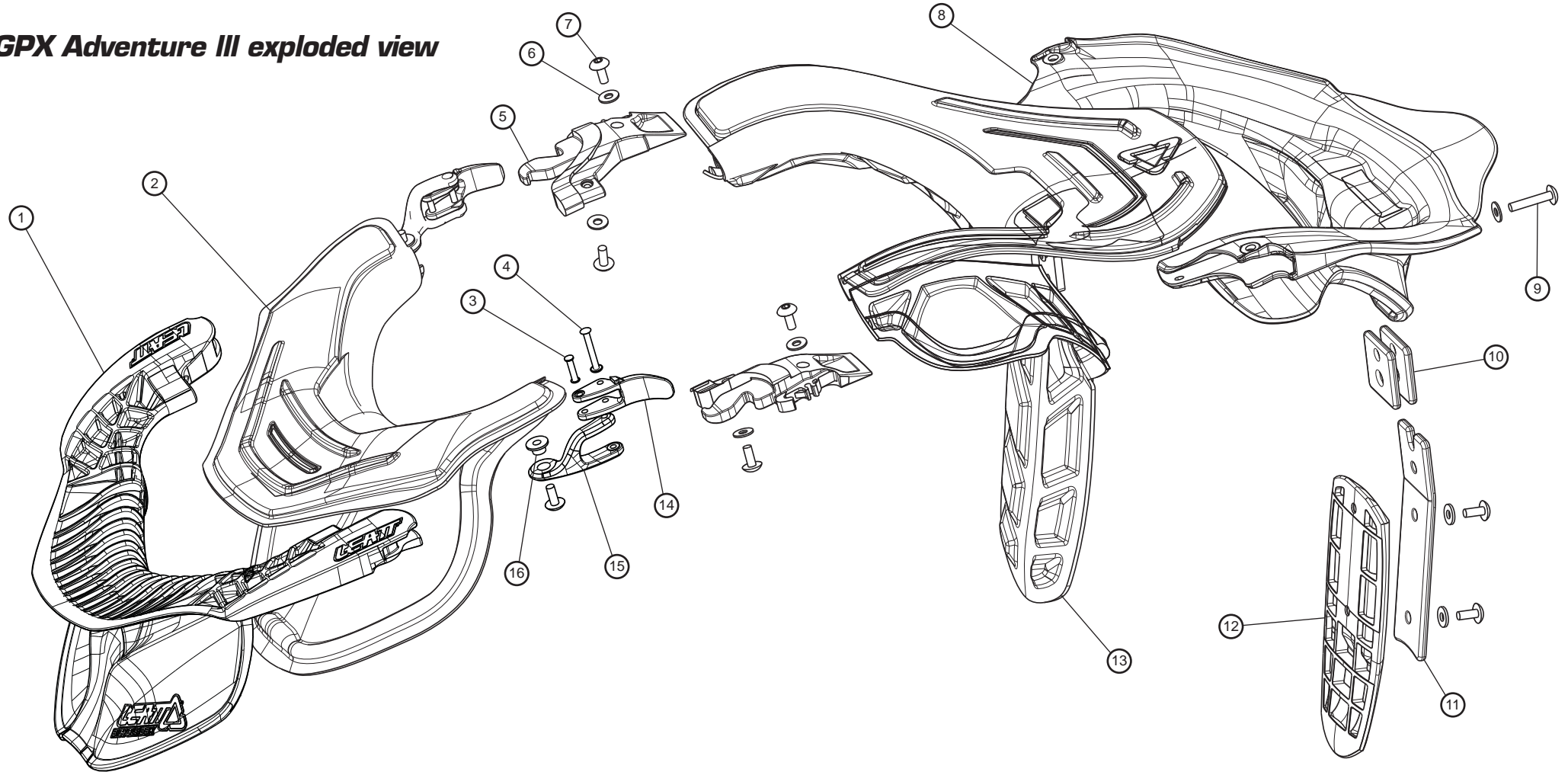

Parts/Components List	QTY		QTY
1 - Front Plastic	1	9 - BHCS M4 22	1
2 - Front Padding	1	10 - Shim	2
3 - Rivet 29 14	2	11 - Strut	1
4 - Rivet 29 24	2	12 - Thoracic	1
5 - Spacer 10MM	2	13 - Back Padding	1
6 - Stainless Steel Washer 08	5	14 - Lever	2
7 - BHCS M4 10	4	15 - Hinge	2
8 - Back Plastic	2	16 - Step Washer	2



## User manual introduction

Welcome to the world of Leatt® and thank you for choosing our product. The Leatt-Brace® you have purchased is based on years of academic research and extensive evaluation of the mechanisms of head and neck injuries, together with testing in test facilities and via simulation software. The brace has been tested using various static and dynamic tests. The Leatt-Brace® is part of the protective equipment ensemble available for use by participants in cycle and motor sports activities.

The design rationale behind the Leatt-Brace® is to help bring the head to a controlled stop during an accident/fall. This is achieved by providing a padded rigid structure that helps act as an alternative load path for neck forces. Helmet impacts otherwise transmitted from the helmet to skull and then to the neck are re-directed from the helmet to the brace and then to other body structures. The design of the Leatt-Brace® helps prevent the helmet/head from projecting over the brace and therefore helps prevent a fulcrum action which has been documented in literature pertaining to the use of collar devices. The Leatt-Brace® may be worn with most types of bicycling body armor and chest protectors. Over long distances, the Leatt-Brace® will also offer some relief from neck fatigue.

The Leatt® DBX neck brace system helps prevent the following extreme movements:

- head, forward – HyperFlexion
- head, rearward – HyperExtension
- head, sideways – Lateral HyperFlexion
- head/helmet, rearward on the neck – Posterior HyperTranslation
- coupled axial loading – Helps prevent axial loading only when the axial forces act in combination with other mechanisms.

The Leatt-Brace® has also been tested against the manufacturer's specifications and EC Type\* and it is CE marked to denote compliance with the EU Personal Protective Equipment Directive 89/686/EEC.

Please e-mail any comments you might have to [info@leatt.com](mailto:info@leatt.com).

The Leatt® GPX Adventure III Brace (*Figure 1*) has been designed to be set up in stages to suit your requirements. Please follow the fitment process carefully. It should take you about 20 minutes to complete.

\*Examination certification has been issued by SGS United Kingdom, Ellesmere Port CH65 3EN, England UK; Notified Body No. 0120.

Figure 1



**Please note:** The product shown may vary in colour. Brace components are depicted in contrasting colours to indicate individual identification.

## Test specifications

Test specifications including the following have been used in the evaluation of this product:

- Eurotype Hybrid III instrumented sled tests (Land Mobility Technologies document No.P/2/00/00431, May 2004)
- BMW Pendulum Testing and Validation Model using Lifemod™ – BMW Test Facilities, Munich, Germany (2006)
- Innovations at BMW Motorrad in the development of equipment for motorcycle riders to reduce the risk of injuries based on the example of the Neck Brace System (proceedings of the 6th International Safety - Environment - Future Conference; Cologne, Germany, 9 – 10 October 2006)
- Side Impact Simulations Using a Validated Pendulum Test Methodology (Leatt® Corporation Biomechanics Division)
- Leatt® Manufacturing Test Specification Issue 2
- EN 340 – “Protective clothing – General Requirements”

The first five test specifications listed assess the ability of the Leatt-Brace® to help reduce forwards and backwards movement of the wearer's head and neck in a collision, or when impacting the road surface. “Leatt® Manufacturing Test Specification Issue 2” includes evaluations of the resistance of the Leatt-Brace® fastenings to opening in the event of an impact. The chemical content of the materials and components used in the construction of the Leatt-Brace® has been assessed in accordance with the requirements of EN 340.

## Leatt-Brace<sup>®</sup> sizing chart

The size of the brace should be correct for your body shape and allows for adjustability to ensure correct fitment and comfort, no matter what your application is.

When correctly adjusted and worn with your helmet, the Leatt-Brace<sup>®</sup> should allow for a full safe range of a rider's head and neck movements (i.e. looking up, looking down and looking side-to-side, such as when performing an over-the-shoulder check); **the Leatt-Brace<sup>®</sup> and the helmet must come into contact with each other as the full safe range of normal riding head movement is reached.**

If any resistance or discomfort is experienced when attempting to complete the full range of head and neck movements, or if the brace does not make contact with the helmet when the full range of movement is reached, further adjustment, or an alternative size of Leatt-Brace<sup>®</sup> may be required. In extreme circumstances, it may be necessary to purchase an alternative model of helmet in order to achieve the required level of compatibility and safety.

Please ask the retailer or contact Leatt<sup>®</sup> if you require further advice on sizing, adjustment or fitting.

Please use the sizing chart below to ensure that you have purchased the correct size Leatt-Brace<sup>®</sup>. The sizing chart is based on your height and chest circumference right below the arms therefore make sure that you take the correct measurements before utilizing the chart on next page.



## Sizing Chart

### Size Range

Small: 4 - 16 years old (thin build) to fit wearer height: 97.5 – 165 cm

Medium: 16 years + (average to bigger build) to fit wearer height: 165 cm +

		Chest circumference .....				Inches cm
		21.6 - 33.5	33.9 - 35	35.4 - 37	37.4 - 43.3+	
Height .....		55 - 85	86 - 89	90 - 94	95 - 110+	
3'6" - 4'7"	106 - 139	sml				
4'7" - 5'1"	140 - 155	sml	sml/med			
5'1" - 5'4"	156 - 163	sml	sml/med	med		
5'4" - 5'5"	164 - 166	sml	sml/med	med	med	
5'6" - 5'7"	167 - 169	sml	sml/med	med	med	
5'7" - 5'8"	170 - 172	sml	sml/med	sml/med	med	
5'8" - 5'9"	173 - 175	sml	sml	sml/med	med	
5'9" - 5'10"	176 - 178	sml	sml	sml/med	med	
5'10" - 5'11"	179 - 181	sml	sml	sml/med	med	
5'11" - 6'	181 - 183		sml	sml/med	med	
6' - 6'1"	183 - 185			sml/med	med	
6'1" - 6'3"+	185 - 190+				med	

ft

cm

\* sml/med refers to either a medium on the smallest setting or a small on the biggest setting

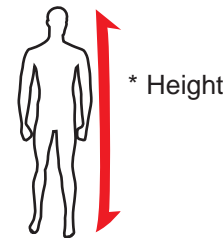

\* Height

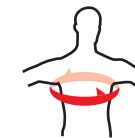

\* Chest circumference right below the arms

### Leatt-Brace® fitment - step 1

The brace has been fitted on a wide range of users and Motorcycle types and should fit you. If not, minor adjustments may be required for proper fit. Failure to properly adjust the brace before use may compromise rider safety and brace effectiveness. When correctly-adjusted and worn with the user's safety helmet, the Leatt-Brace® should allow the full range of normal head and neck movements (i.e. looking up, looking down and looking side-to-side, such as when performing an over-the-shoulder check); the Leatt-Brace® and the helmet only coming into contact with each other as the full range of normal movement is reached.

Your DBX Comp 3 brace is supplied with four pairs of different sized Spacers for adjustment. The Medium Spacer is fitted as standard. Start by fitting your brace without the thoracic assembly attached on your shoulders and chest as shown below in Figure 2.

Figure 2



#### Adjustment with Spacers

If the brace is too loose around your neck with the fitted Medium Spacer and does not sit comfortably on your shoulders and chest, fit the Short Spacer (see Figure 3). If the brace is too short and therefore too tight, simply fit the Long Spacer.

Figure 3: Spacer sizes

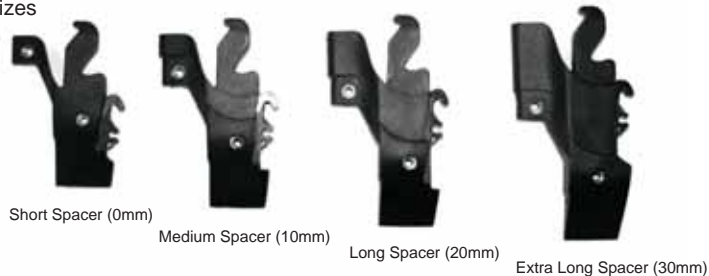

### Fitting the Spacers

Unscrew the 2 Buttonhead Cap Screws (see Figure 4a) with the supplied Allen key. Slide the Spacer out once the Cap Screws are removed (see Figure 4b) and replace by sliding the desired Spacer back in the same way. Now screw in the 2 Buttonhead Cap Screws with its washers in place to secure the newly fitted Spacer.

Figure 4a:

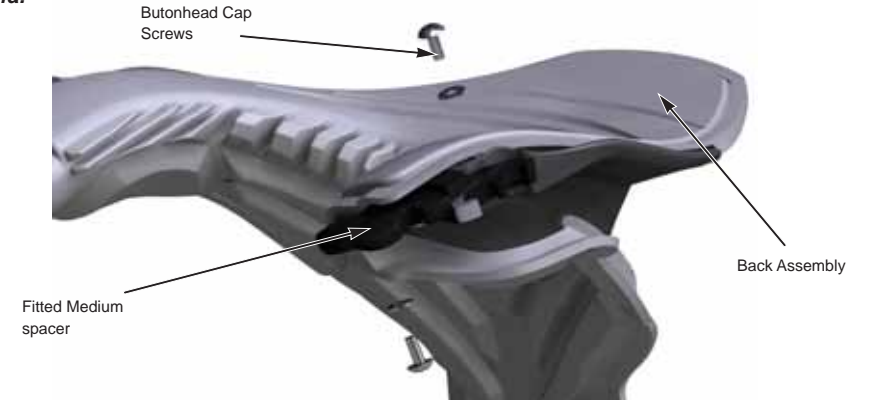
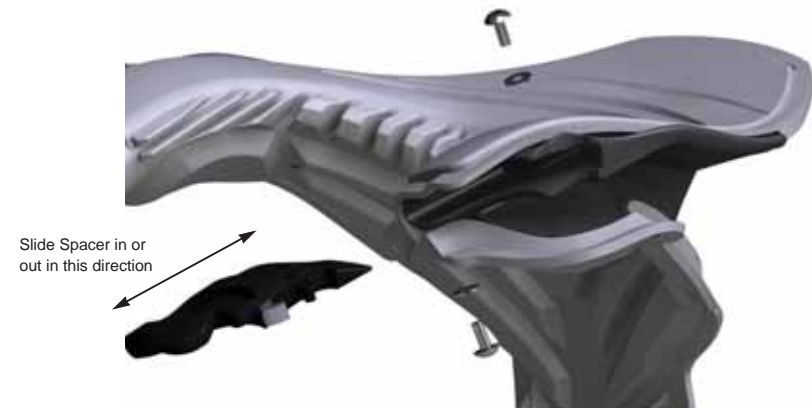

Figure 4b:





### Strut and thoracic assembly - step 2

Now attach the strut onto the thoracic assembly as shown in *Figure 5a & b*.

#### 7 Degree Wedge

Slender riders can insert the 7 Degree Wedge upright between the thoracic assembly and the strut (*Figure 6*).

**DO NOT USE THE WEDGE WITH THE 17 DEGREE STRUT.**

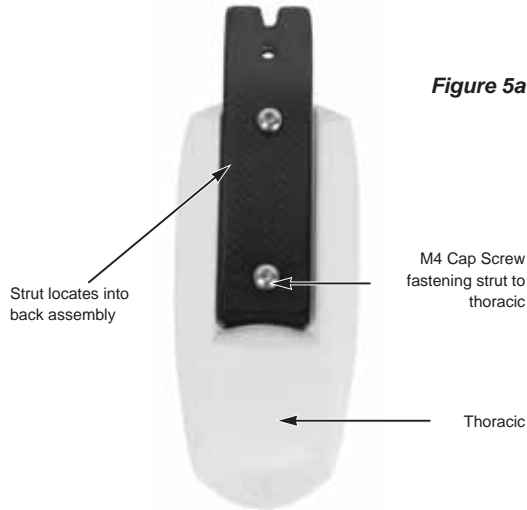

Figure 5a

Figure 5b

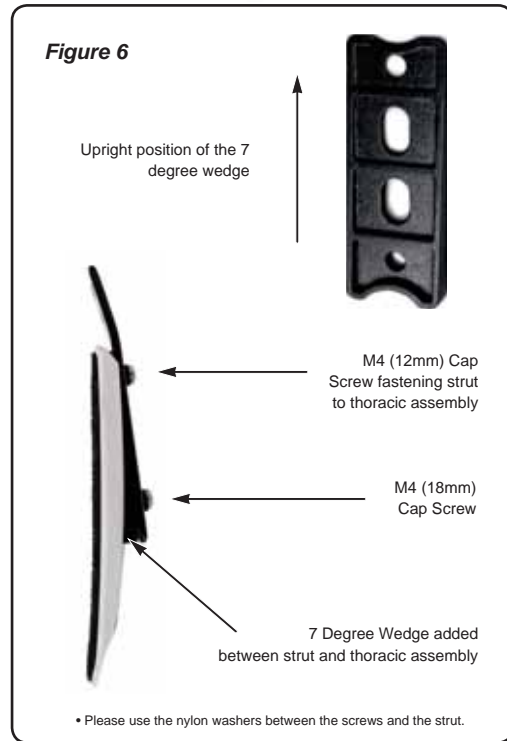
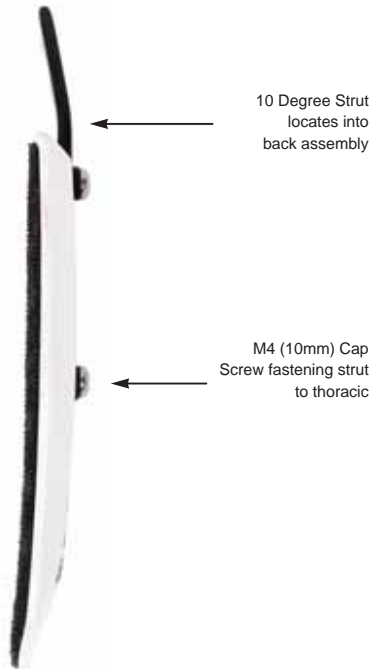

Figure 6

### Strut and thoracic assembly - step 2 (Continued)

Insert the strut into the rear member of the brace, starting with one shim on either side of the strut (*Figure 7a*). The strut and shim will always be contained within the brace so that you can adjust the brace at any time. There is no need to fit the locking cap screw (*Figure 7b*) at this time. Now refit the brace. If the brace is pulled slightly backward, place the two shims before the strut (towards the front of the brace), if the brace has become too loose, place the two shims behind the strut (towards the rear of the brace).

Figure 7a



Figure 7b



### Opening and Closing the Leatt-Brace®

You can either hinge open the Leatt-Brace® from the left or right (*Figure 8a*) or remove the front member completely (*Figure 8b*).

Figure 8a



Figure 8b



## Padding inserts

When the 10, 20 and 30mm spacer is used, fit padding insert to cover exposed spacer on the inner brace structure.

1. Peel back rear padding to expose velcro
2. Place padding insert over exposed spacer
3. Re-apply padding

1.



2.



3.



## Torque settings for screws

All screws except the clip hinge countersunk screws should be maintained at 2Nm.  
The clip hinge screws should be maintained at 1Nm.

## Padding Fitment

The GPX Adventure Padding is fitted through a series of Velcro straps. Start fitting the padding on the Velcro straps situated at the top tips of the front and back plastics (see Figure 9a). Wrap each padding down the inside of the brace towards the lower part of the plastic or thoracic where the padding is attached to Velcro straps (Figure 9b). Please be sure to use the front padding on the front plastic and the back padding on the back plastic of the brace.

Figure 9a



Figure 9b



## Chest strap

Once your GPX Adventure is set up correctly to your body size and shape, you also have the option of attaching the Chest Strap. Although this is not a vital component, the Chest Strap can provide additional stability and comfort. To attach the chest strap lift the bottom padding of the front and back paddings (Figure 10a). Place one of the attachment straps of the chest strap on the inside of the front plastic and one on the inside of the back plastic. Reattach the paddings (Figure 10b). Both front and back need to be attached to be effective.

Figure 10a



Figure 10b





## Fitting the GPX Adventure III with body armor

If you use a body armor system, place the thoracic member under your back protector and then choose whether you wish to place the front member of your Leatt-Brace® under or over the padding of the body armor (*Figure 11a*).

**Figure 11a**



**Figure 11b**



May be worn under or on top of body armor as long as thoracic is under the back protector (*Figure 11b*).

If you use a chest protector, the lower front member should be inside the chest protector and the upper front member should be outside the chest protector (*Figure 12a*). The same applies to the rear upper and lower members (*Figure 12b*).

If your chest protector is a smaller size, you may have to widen the head opening of the chest protector. Most chest protectors allow for this adjustment. In the case of very small children, allow the front lower portion to rest on the outside of the chest protector. Some junior riders elect to remove the hard outer portion of the shoulder padding from their chest protectors for comfort.

**Figure 12a**



**Figure 12b**



## Looking after your Leatt-Brace®

You may want to wash your Leatt-Brace® after hard riding. The brace and integrated padding should only be washed with a gentle soap or detergent in cold water, rinsed in cold water and dried with a cloth only. Common substances applied to this brace (solvent, cleaners, hair tonics, etc.) can cause damage that may be invisible to the user and compromise the effectiveness/safety of the Leatt-Brace®. Always refer to the material content label on the Leatt-Brace®. None of the materials used are known to contain anything that might cause an allergic reaction or be dangerous to your health.

When storing your Leatt-Brace®, place it on a clean, dry surface and store in a dry, well-ventilated environment away from direct sunlight and extremes of temperature. Do not place heavy objects on top of the Leatt-Brace®.

For maximum performance the Leatt-Brace® must be inspected prior to each use. Stop using the Leatt-Brace® if any of its components, including but not limited to, the Front Component, Hinge Lever Assembly, Spacers, Strut, Nylon Washers and/or the Back Component (See Parts/Components List on page 3) are worn, cracked and/or deformed, or if the inside padding has deteriorated.

We wish you many safe hours of enjoyable racing and riding with your Leatt-Brace®. Please contact us with any questions or comments at [info@leatt-brace.com](mailto:info@leatt-brace.com). We recommend that you replace your Leatt-Brace® every two years of normal racing conditions and replace any components that are damaged in a serious accident.



