

User Manual

UIM240XX Series
Step/Direction Control
Miniature Integrated Stepper Motor Driver



UIM24002/04/08

Please pay attention to the following before using the Mach Motion products:

- Mach Motion products meet the specification contained in their particular Data Sheet.
- Mach Motion will only work with the customer who respects the Intellectual Property (IP) protection.
- Attempts to break Mach Motion's IP protection feature may be a violation of the local Copyrights Acts. If such acts lead to unauthorized access to Mach Motion's IP work, Mach Motion has a right to sue for relief under that Act.

Information contained in this publication regarding controller applications and the like is provided only for your convenience and may be superseded by updates. It is your responsibility to ensure that your application meets with your specifications. Mach Motion makes no representations or warranties for any kind whether express or implied, written or oral, statutory or otherwise, related to the information, including but not limited to its condition, quality, performance, merchantability or fitness for purpose. Mach Motion disclaims all liability arising from this information and its use. Use of Mach Motion products in life support and/or safety applications is entirely at the buyer's risk, and the buyer agrees to defend, indemnify and hold harmless Mach Motion from any and all damages, claims, suits, or expenses resulting from such use. No licenses are conveyed, implicitly or otherwise, under any Mach Motion intellectual property rights.

[Trade Mark/ Layout-design/Patent]

The UIROBOT name and logo are registered trademarks of UIROBOT Ltd. in the P.R. China and other countries. UIROBOT's UIM24XXX series Step Motor Controllers, UIM25XX series CAN-RS232 Converter and their layout designs are patent protected.

[UIM240XX Ordering Information]

In order to serve you quicker and better, when you order UIM240XX series controller, please provide the product number in following format.

UIM240XX PART NUMBERING SYSTEM

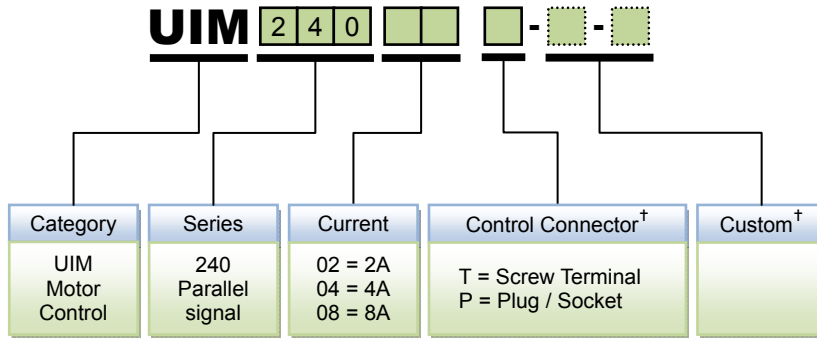

Note: [†] Optional. Default control connector is T (screw terminal) if not selected.

Examples: UIM24004, UIM24004P, UIM24008P, etc.

Examples of Control Connector options:

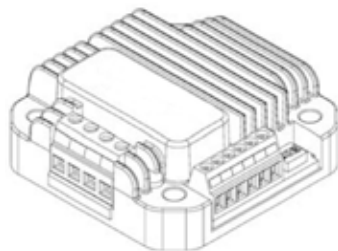

Screw Terminal

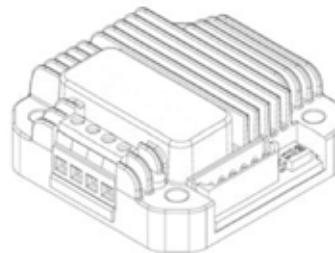

Rectangular Plug / Socket

UIM240XX Miniature Integrated Stepper Motor

UIM24002/24004/24008

Parallel Signal Control

Miniature Integrated Stepper Motor Driver

FEATURES

- Miniature size 42.3mm*42.3mm*16.5mm
- Integral design
- Wide range input voltage 10-40VDC
- 0 - 2A / 1.5 - 4A / 3 - 8A adjustable output current
- 1 to 16th micro stepping
- Automatic Current Reduction
- Dual full H-bridge with PWM constant current control
- Enable/shutdown input for power saving
- Optical-isolated inputs
- Die-cast aluminum enclosure

DESCRIPTION

UIM240XX Miniature Stepper Motor Drivers are series miniature, high performance stepper motor controllers. They can be mounted onto NEMA 17 / 23 / 34 / 42 series stepper motor seamlessly through corresponding flanges. The thickness of these controllers is less than 15 mm.

The UIM24002 outputs 0-2A adjustable current, the UIM 24004 outputs 1.5-4A adjustable current and the UIM24008 outputs 3-8A adjustable current. Their mixed-decay current control reduces the back-EMF effect under high motor speed and improves the performance. Except that UIM24002 takes 10-35VDC input, UIM240XX series controllers work on 12 - 40VDC input.

The enclosure is made of die-cast aluminum which provides a rugged, durable protection and improves the heat dissipation.

TERMINAL DESCRIPTION

Figure 0-1: Wiring Terminal

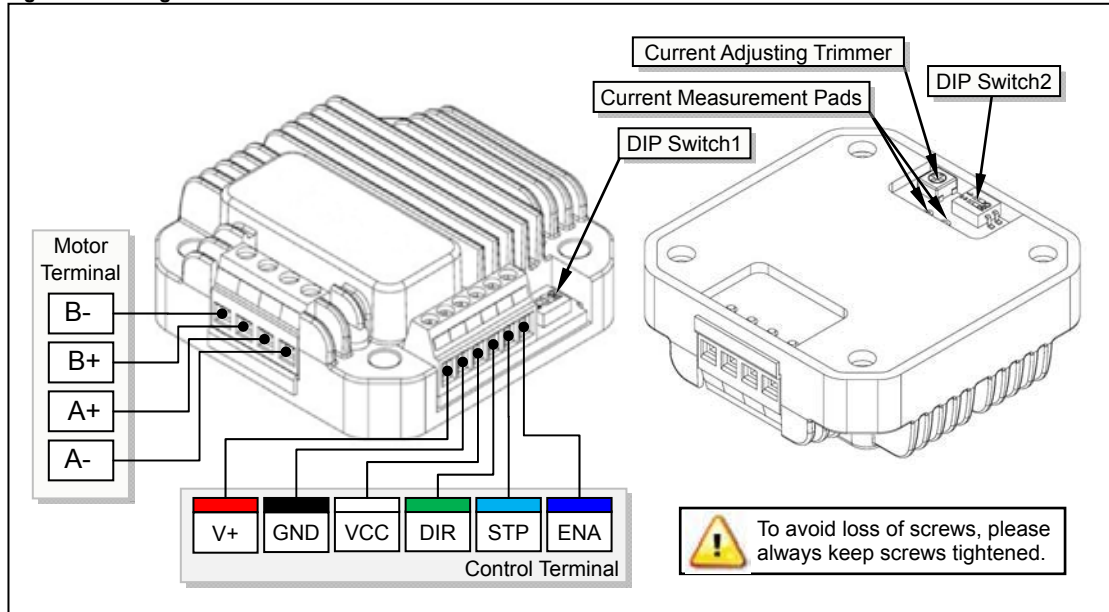

Control Terminals

Terminal No.	Designator	Description
1	V+	Supply voltage, 12 - 40VDC
2	GND	Supply voltage ground
3	VCC	Opto-coupler common anode
4	DIR	Direction input ⁽¹⁾
5	STP	Stepping pulse input ⁽²⁾
6	ENA	Enable the controller ⁽³⁾

Note:

- (1) Input is considered high level if this terminal is not connected.
- (2) Low-level pulse duration should > 4 μ s.
- (3) An active low-level input shuts down power supply to the motor. High-level input or left open makes the controller fully working. When awoken from shutdown mode, wait 1 millisecond before sending pulse.

Motor Terminals

Terminal No.	Designator	Description
1/2	A+ / A-	Connect to the stepper motor phase A
3/4	B- / B+	Connect to the stepper motor phase B



Warning: Incorrect connection of phase winds will permanently damage the controller.

Resistance between leads of different phases is usually > 100K . Resistance between leads of the same phase is usually < 100 .

UIM240XX Miniature Integrated Stepper Motor

TYPICAL APPLICATION

UIM240xx controller's wiring is very straightforward as shown in following Figure. Terminal 6 (EN) can be left open if offline is not needed.

Figure 0-2: Typical Application

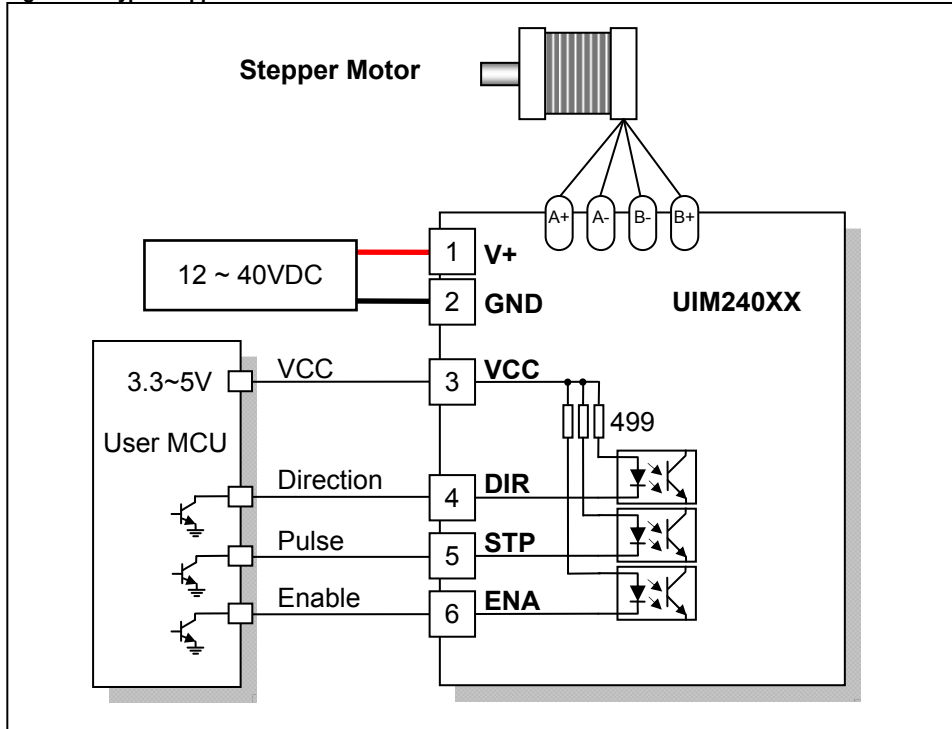

OPTICALLY ISOLATED INPUT INTERFACE

UIM240xx controllers' logic control inputs are all optically isolated. All opto-isolators share one common anode (VCC) as shown in above schematic diagram. Typically, VCC is 5V. However, 3.3V or voltages higher than 5V are also acceptable, so long as the current through the opto-isolator's emitter is between 5~20mA.

Should a voltage higher than 5V be applied to VCC, an additional resistor is needed for every terminal to ensure that the current through each emitter does not exceed 20mA.

Figure 0-3: Optically Isolated Input Interface

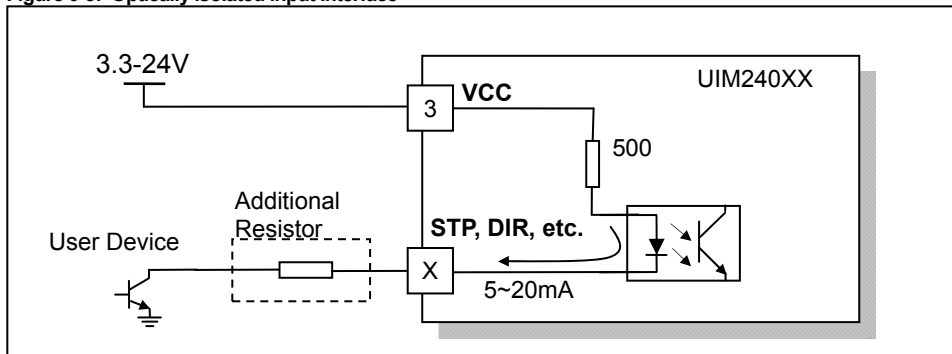

Note, in most situations, VCC can also be used as common cathode connection. This is because the opto-isolators used in UIM240 are bidirectional (AC&DC) type.

CHARACTERISTICS

Absolute Maximum Ratings ^(†)

Supply Voltage.....	10V to 40V
Ambient temperature under bias.....	-40°C to +85°C
Storage temperature.....	-50°C to +150°C

†NOTICE: Stresses above those listed under "Absolute Maximum Ratings" may cause permanent damage to the device. This is a stress rating only and functional operation of the device at those or any other conditions above those indicated in the operation listings of this specification is not implied. Exposure to maximum rating conditions for extended periods may affect device reliability.

Electrical Characteristics (Ambient Temperature 25°C)

Supply Power Voltage	12 – 40VDC (10 – 35VDC for UIM24002)
Motor Output Current	Max 2A/4A/8A per phase (Adjustable through on-board trimmer)
Driving Mode	PWM constant current
Stepping Resolution	Full, 1/2 step, 1/4 step, 1/8 step, and 1/16 step
Insulation Resistance	>100MΩ
Dielectric Strength	0.5KV in one minute

Communication (Ambient Temperature 25°C)

Parallel Communication	3-wire interface: Pulse, Direction, Shutdown
Micro Step Resolution	1, 1/2, 1/4, 1/8, 1/16 set through on-board DIP switch 1 and switch 2

Environment Requirements

Cooling	Free air
Working environment	Avoid dust, oil mist and corrosive gases
Working temperature	-40°C ~ 85°C
Humidity	<80%RH, no condensation, no frosting
Vibration	3G Max
Storage temperature	-50°C ~ 150°C

Size and Weight

Size	42.3mm x 42.3mm x 16.5mm (L*W*H)
Wight	0.1 kg

UIM240XX Miniature Integrated Stepper Motor

FUNCTIONAL DESCRIPTION

Supply Voltage

UIM240xx controllers accept a wide range input voltage from 12 to 40VDC. (UIM24002 takes 10 – 35 VDC) In general, higher supply voltage improves motor performance under high speed situation, but also increases the power loss and temperature raise.

Automatic Current Reduction (ACR)

UIM240XX controller is featured of Auto Current Reduction. If this function is enabled, when the motor stops running, the phase current will be cut to 50% of the set value. As soon as the motor goes back to working, the current will go back to the set value. This function is enabled by turn the DIP1 (figure 0-4) of the DIP switch 2 to the ON position.

Adjust Output Current

UIM24002/04/08 is capable of providing maximum 2A / 4A / 8A per phase output current respectively. In specific application, the peak output current needs to be adjusted to meet the rated motor current. A trimmer (potentiometer) is provided to serve this purpose at the bottom of the controller, as shown in the following figure. Measuring the mapped voltage (V_a) when tuning the trimmer provides a easy way to set the output current.

For UIM24002, a mapped voltage " V_a " of 0 - 2V proportionally represents 0 ~ 2A.

For UIM24004, a mapped voltage " V_a " of 0 - 4V proportionally represents 0 ~ 4A.

For UIM24008, a mapped voltage " V_a " of 0 - 4V proportionally represents 0 ~ 8A.

Note:

1. The controller needs to be powered before mapped voltage " V_a " can be measured. (Motor is not required to be connected at this time.)
2. DIP1 (on the bottom side DIP switch 2) needs to be turned off to shut down the ACR Function.
3. After adjustment, user can choose to turn on the DIP1 to enable the automatic current reduction.

Figure 0-4: Adjusting the Output Current

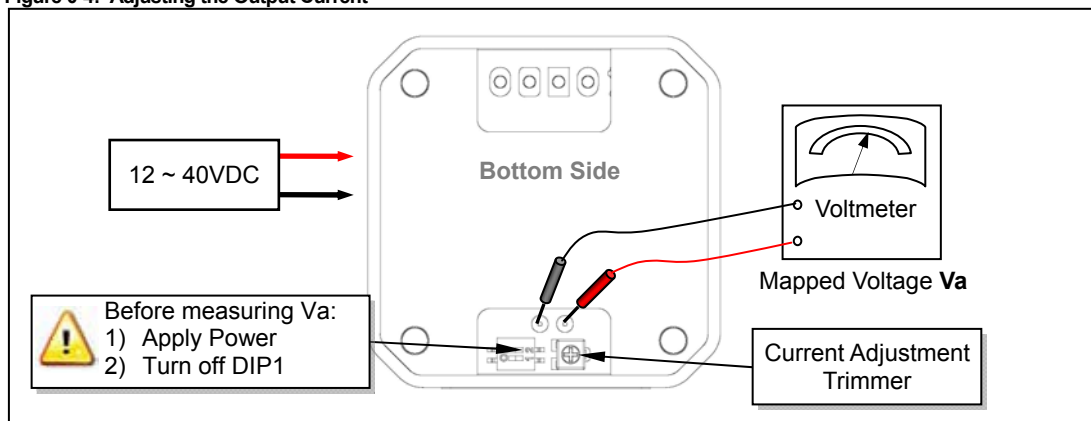

Micro Stepping Resolution

The micro stepping resolution is set by both DIP switch 1 and DIP switch 2 located at top and bottom side of the driver as shown in following figure. UIM240xx controller can provide micro-stepping control at full-step, 1/2, 1/4, 1/8 and 1/16 step resolutions.

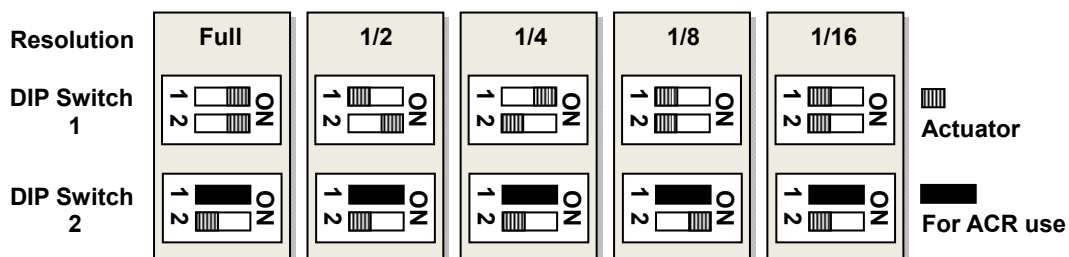

APPENDIX A DIMENSIONS

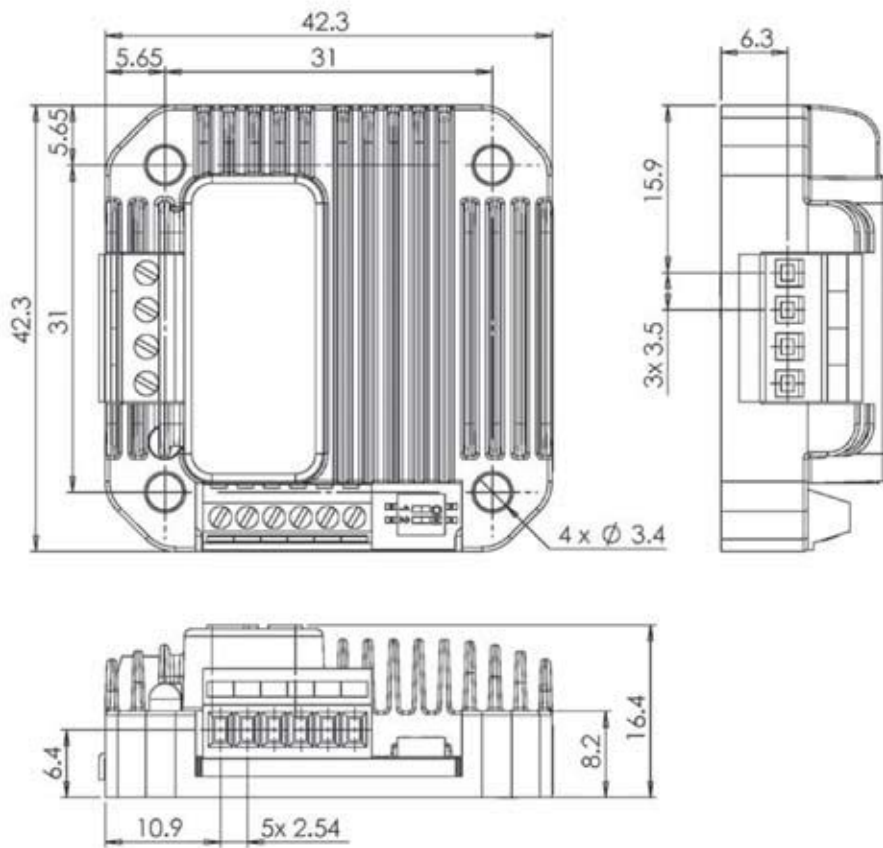

Units: mm

UIM240XX Miniature Integrated Stepper Motor

APPENDIX B INSTALLATION

NEMA 17 Stepper Installation (without adapting flange)

1. Screw mount UIM controller / driver onto the motor
2. Wire the motor leads.

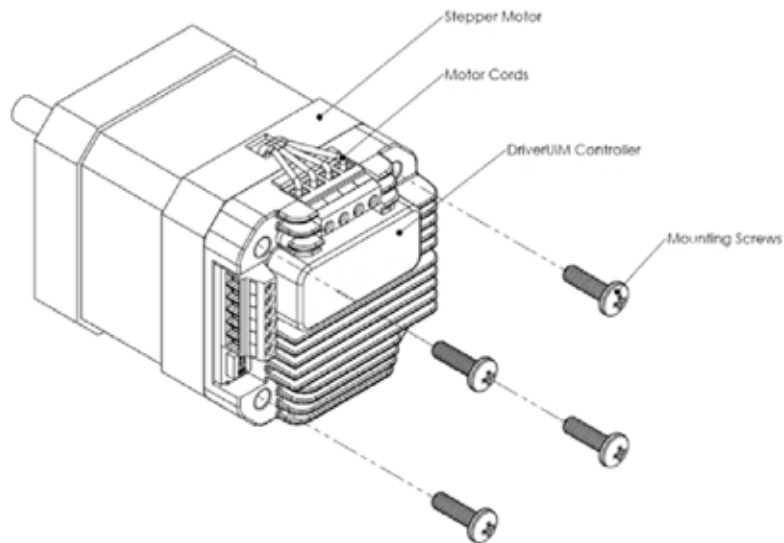

NEMA 23 and Larger Stepper Installation (with adapting flange)

1. Screw mount the adapting flange onto the motor
2. Screw mount UIM controller / driver onto the adapting flange
3. Wire the motor leads.

