

Digital Heater Element Burnout Detector K8AC-H



A high-precision Heater Element Burnout Detector compatible with a wide-range of heater control methods.

- Compatible with contactor, SSR, cyclic control, and phase control methods.
- Compatible with a wide range of heater capacities, from 0.200 to 200.0 A AC (range covered by 3 models)
- Voltage fluctuation compensation function enables accurate heater burnout detection, because power supply voltage fluctuations resulting in heater current fluctuation will not cause faulty outputs.
- Detects burnouts for even one heater when using multiple heaters.
- If the gate function is disabled, the gate input can be used as an undercurrent/overcurrent relay or for motor or lamp loads (2 circuits).
- CE Marking.
- Contributes to preventative maintenance for heater burnout.

Note: Consult with your OMRON representative before using phase and cyclic control under the following conditions.

- Using multiple heaters with different heater capacities
- Using heaters with varying heater resistance (e.g., halogen heaters)



Features

Compatible with Many Heater Control Methods

The K8AC-H detects burnouts for cyclic and phase control heaters, which could not be detected by the K2CU. One Digital Heater Element Burnout Detector can handle single-phase or three-phase heaters.

Item	Type	ON/OFF control (connector/SSR)		Cyclic control	Phase control
		K8AC-H□□C□-FLK		K8AC-H□□P□-FLK	
Single-phase heater		○	○	○	○
Three-phase heater		○	○	○	○

Applicable to Wide Current Range

Current can be measured between 0.200 and 200.0 A using an external current transformer.

Item	Model	K8AC-H11□	K8AC-H12□	K8AC-H13□
Current measurement range		0.200 to 2.200 A AC	2.00 to 22.00 A AC	20.0 to 200.0 A AC
Appropriate Current Transformer model		K8AC-CT20S K8AC-CT20L	K8AC-CT20S K8AC-CT20L	K8AC-CT200 K8AC-CT200L

Monitors Heater Current

The heater current can be checked on the main display. Error status, such as that for heater burnout alarms, can also be displayed on the character display.

- ◆ Measurement values
 - Heater current
 - Power supply voltage
- ◆ Error display
 - Heater burnout detection
 - Overcurrent detection
 - SSR short circuit detection
 - SSR open circuit detection

Main display →



Voltage Fluctuation Compensation Function

The voltage fluctuation compensation function enables accurate heater burnout detection, because power supply voltage fluctuations resulting in heater current fluctuation will not cause faulty outputs. This function is required when detecting minor current fluctuations.

High-precision Heater Burnout Detection

Digital settings enable high-precision heater burnout detection. High-precision threshold value setting is possible using current measurement value display.

SSR Short Circuit Detection

Quickly detects control failures caused by SSR short circuits. Useful for preventing shipping of faulty products and for improving productivity.

Detects Overcurrents in Heater Circuits

Detects overcurrents from heater layer shorts and outputs an alarm. Useful for preventing SSR deterioration caused by overcurrents.

RS-485 Communications

Measurement data, such as the present heater current, maximum/minimum heater current, and power supply voltage, can be read using RS-485 communications. The current when the heater burned out and the total operating time are recorded in memory, and this data can be used for preventative equipment maintenance. (This data can be checked on the main display.)

CE Marking

Compact Unit

(35 × 90 × 100 mm (W × H × D))

Problems with Current Heater Element Burnout Detectors

- K2CU Heater Element Burnout Detectors could not detect burnouts with cyclic or phase control heaters (performed unnecessary operations). Generally, heater burnouts could not be detected even by the heater burnout detection function of power regulators (phase control devices) when multiple heaters were connected. Also, burnout detection was not accurate when temperature controller outputs were small.

- Power voltage fluctuations in the heater circuit caused current fluctuations. Without a voltage fluctuation compensation function, voltage fluctuations cause unnecessary operation.
- The K2CU has a narrow rated current range and cannot detect minute current fluctuations when multiple heaters are detected due to the low resolution.

Differences from Other Current Heater Element Burnout Detection Functions

Classification Item		Heater Element Burnout Detector		Temperature controller	Power regulator (thyristor)
		K8AC-H	K2CU		
Heater burnout detection	Single-phase heater	○	○	○	○
	Three-phase heater	○	○	○	○
	Contact control heater	○	○	○	○
	SSR control heater	○	○	○	○
	Phase control heater	⊙	×	×	○
	Cyclic control heater	⊙	×	×	×
Voltage fluctuation compensation function		⊙	○	×	×
SSR short circuit detection function		○	×	○	×
Overcurrent detection function		○	×	×	○

⊙: Can detect with high precision ○: Can detect ×: Cannot detect

Model Number Structure

■ Model Number Legend

K8AC-H1 □□□ -FLK 100-240VAC
 1 2 3 4 5 6 7

1. Basic Model

K8AC-H: Digital Heater Element Burnout Detector

2. Product Type

1: Series number

3. Current Input Range

1: 0.200 to 2.200 A

2: 2.00 to 22.00 A

3: 20.0 to 200.0 A

4. Heater Control Type

C: ON/OFF control (SSR or contactor)

P: Phase control or cyclic control

5. Output Type

C: Relay contact output (one SPDT relay contact output)

T: Transistor output (two NPN open collector outputs)

6. Communications Specifications

FLK: RS-485

7. Power Supply Voltage

100-240VAC: 100 to 240 VAC

Ordering Information

■ Digital Heater Element Burnout Detectors

Heater control method	Input specifications	Output specifications	Current input range	Model
Contactor control SSR control	Two current inputs (single-/three-phase)	One relay output + RS-485	0.200 to 2.200 A	K8AC-H11CC-FLK
			2.00 to 22.00 A	K8AC-H12CC-FLK
			20.0 to 200.0 A	K8AC-H13CC-FLK
		Two transistor outputs + RS-485	0.200 to 2.200 A	K8AC-H11CT-FLK
			2.00 to 22.00 A	K8AC-H12CT-FLK
			20.0 to 200.0 A	K8AC-H13CT-FLK
Phase control (cyclic control)		One relay output + RS-485	0.200 to 2.200 A	K8AC-H11PC-FLK
			2.00 to 22.00 A	K8AC-H12PC-FLK
			20.0 to 200.0 A	K8AC-H13PC-FLK
		Two transistor outputs + RS-485	0.200 to 2.200 A	K8AC-H11PT-FLK
			2.00 to 22.00 A	K8AC-H12PT-FLK
			20.0 to 200.0 A	K8AC-H13PT-FLK

Note: Consult with your OMRON representative if multiple heaters are connected in parallel with different heater capacities, or if a heater with varying heater resistance is used.

■ Optional Products (Sold Separately)

Current Transformers

Through-hole diameter	Rated current	Installation method	Model
5.8 mm dia.	0.200 to 22.00 A	Surface-mounted with screws	K8AC-CT20S
12 mm dia.		Rear-surface mounted with screws Binding band	K8AC-CT20L
		20.0 to 200.0 A	Rear-surface mounted with screws Binding band
30 mm dia.	20.0 to 200.0 A	Surface-mounted with screws	K8AC-CT200L

Note: When selecting a current transformer, ensure that the rated current of the heater does not exceed the rated current of the transformer.

Specifications

■ Ratings

Power supply voltage	100 to 240 VAC (50/60 Hz) (See note 2.)																
Operating voltage range	85% to 110% min. of the rated power supply voltage (85 to 264 V)																
Power consumption (at max. load)	9.0 VA max. (at max. load)																
Applicable circuits	Single-phase or three-phase (with same model)																
Applicable control methods	Contactor ON/OFF control (e.g., temperature controller with relay output) SSR control (e.g., temperature controller with voltage output) Cyclic control and phase control (e.g., temperature controller with current output)																
Current measurement	Current measurement via two special CTs (Burnout alarm set value can be set separately for each CT.)																
	<table border="1"> <thead> <tr> <th>Special CT models (See note 3.)</th> <th>Current input range</th> <th>Applicable models</th> </tr> </thead> <tbody> <tr> <td>K8AC-CT20S</td> <td>0.200 to 2.200 A</td> <td>K8AC-H□1□□, K8AC-H□2□□</td> </tr> <tr> <td>K8AC-CT20L</td> <td>2.00 to 22.00 A</td> <td></td> </tr> <tr> <td>K8AC-CT200</td> <td>20.0 to 200.0 A</td> <td>K8AC-H□3□□</td> </tr> <tr> <td>K8AC-CT200L</td> <td>20.0 to 200.0 A</td> <td>K8AC-H□3□□</td> </tr> </tbody> </table>	Special CT models (See note 3.)	Current input range	Applicable models	K8AC-CT20S	0.200 to 2.200 A	K8AC-H□1□□, K8AC-H□2□□	K8AC-CT20L	2.00 to 22.00 A		K8AC-CT200	20.0 to 200.0 A	K8AC-H□3□□	K8AC-CT200L	20.0 to 200.0 A	K8AC-H□3□□	
Special CT models (See note 3.)	Current input range	Applicable models															
K8AC-CT20S	0.200 to 2.200 A	K8AC-H□1□□, K8AC-H□2□□															
K8AC-CT20L	2.00 to 22.00 A																
K8AC-CT200	20.0 to 200.0 A	K8AC-H□3□□															
K8AC-CT200L	20.0 to 200.0 A	K8AC-H□3□□															
Measurement method	Instantaneous measurement using root-mean-square values																
Gate input signal (See note 1.)	Contactor ON/OFF control	Voltage = 12/24 VDC (continuous input possible to 30 VDC) Input impedance = 4 kΩ min.															
	SSR control	ON voltage: 9.6 VDC max., OFF voltage: 1 VDC min. Minimum voltage pulse ON time for burnout detection: 200 ms min.															
	Cyclic and phase control	4 to 20 mA DC (Burnout detection is possible for an input of 7 mA or greater.) Input impedance = 50 Ω max.															
Output ON delay	0.0 to 99.9 s (operating time)																
Soft start time	0.0 to 99.9 s (Used when using a soft start function in the power regulator.)																
Output	Relay contact output: K8AC-H□□□C-FLK	One SPDT relay contact output Same output used for heater burnout alarms, overcurrent alarms, SSR short circuit alarms, and SSR open circuit alarms. 0.3 A at 125 VAC (resistive load), 1 A at 30 VDC (resistive load) Max. switching capacity: 37.5 VA, 30 W Mechanical durability: 50 million operations min., electrical durability: 100,000 operations min.															
	Transistor output: K8AC-H□□□T-FLK	Two NPN open-collector outputs One ALM output: Outputs heater burnout alarms and overcurrent alarms One SSR error output: Outputs SSR short circuit and open circuit alarms. 12 to 24 VDC, 50 mA max. OFF leakage current: 100 μA max., ON residual voltage: 1.5 V max.															
Communications	RS-485 1200, 2400, 4800, 9600, 19200 bps (CompoWay/F)																
Indication method	7-segment digital display: No. of display digits: 4 (red) LED status indicators: RUN (green), ADJ (orange), SET (orange), GATE (orange), SSR (orange) and ALM (orange)																
Main functions	Heater burnout alarms, overcurrent alarms, SSR short circuit alarms, SSR open circuit alarms, voltage fluctuation compensation, output ON delay timer, energy-saving mode, key protection, and power supply voltage measurement																
Memory protection	Non-volatile memory (No. of writes: 100,000)																
Ambient operating temperature	-10 to +55°C (with no icing or condensation)																
Ambient operating humidity	25% to 85% (with no condensation)																
Storage temperature	-25 to +65°C (with no icing or condensation)																

- Note:**
1. The gate input enables correct measurement by syncing to heater control. When using it with contactor ON/OFF control, receive the relay contact output from the temperature controller or other controller with an auxiliary relay and then use this signal as the gate input signal to the K8AC-H. The gate function can also be disabled. If it is disabled, the gate input can be used as a normal undercurrent/overcurrent relay.
 2. When using the K8AC-H for a 380 to 480-V AC power supply circuit, use a step-down transformer. Contact your OMRON representative for information on transformers.
 3. Order the CTs separately.

Connections

Terminal Arrangement

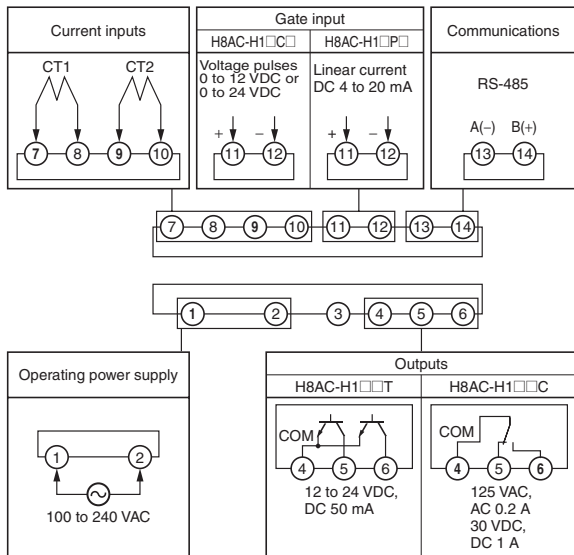

Terminals	Name	Description	Applicable models
1 to 2	Operating power supply	Connect to the operating power supply.	All models
5 to 4, 6 to 4	Outputs	Outputs SSR open or short circuit detection results. Outputs heater burnout or overcurrent detection results.	K8AC-H1□□□T (transistor outputs)
5, 6 to 4		Outputs an OR of the status of all alarms.	K8AC-H1□□□C (relay output)
7 to 8	Current inputs	Connect to CT1. Current input from CT1 secondary-side output.	All models
9 to 10		Connect to CT2. Current input from CT2 secondary-side output.	
11 to 12	Gate input	Connect to gate signal (voltage pulse).	K8AC-H1□□□□
		Connect to a 4 to 20-mA gate signal.	K8AC-H1□□P□
13 to 14	Communications	Connect to host device for RS-485 communications.	All models

- Note:**
- Terminals 4 to 6: Alarm output terminals. Depend on the output type (relay output or transistor outputs).
 - Terminals 11 and 12: Gate input terminals. Depend on the heater control type (contactor/SSR control or cyclic/phase control).

Current Input Circuits

CT Inputs (Heater Current)

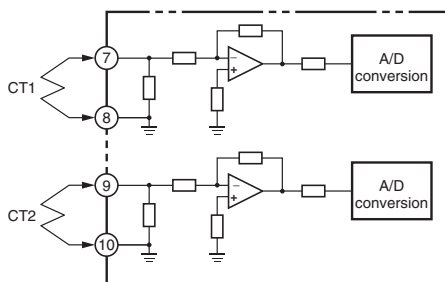

Output Circuits

Open Collector Outputs

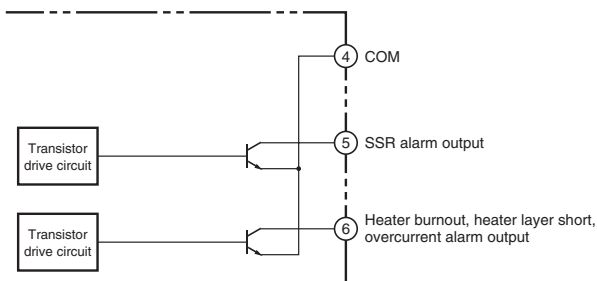

Contact Outputs

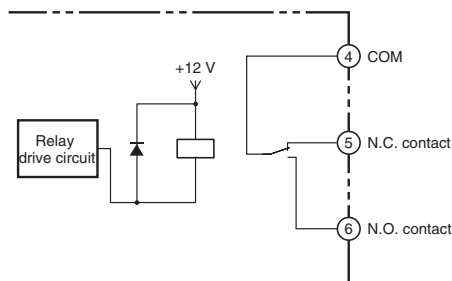

Note: For contact outputs, the same outputs are used for SSR error and for heater burnouts and heater layer shorts alarm outputs.

External Connection Example

Wiring Method When Using the K8AC-H with SSR Control Heaters

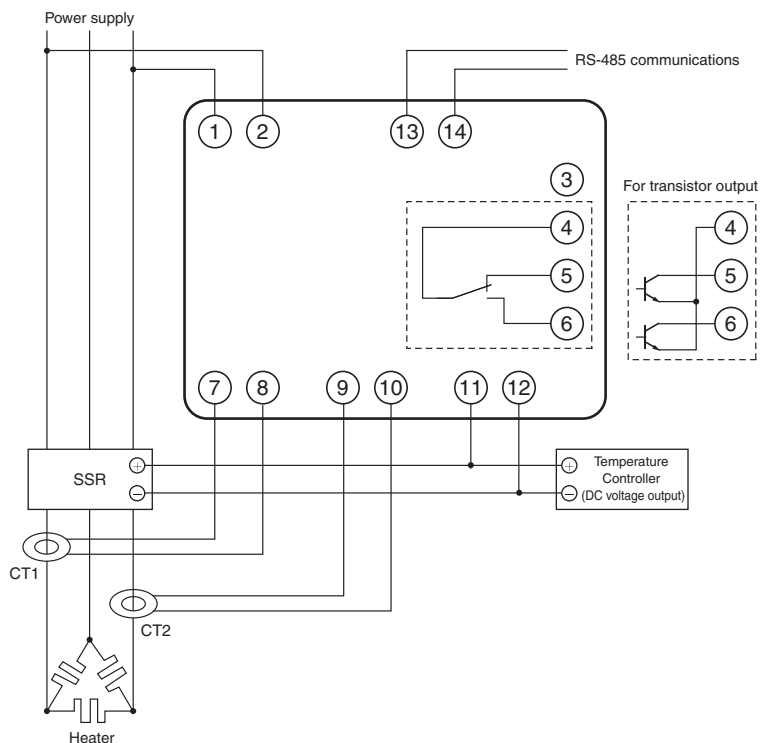

Operation Description

- If the heater current detected at either CT1 or CT2 falls below the burnout alarm set value, an alarm is output. The burnout alarm set value can be set separately for CT1 and CT2. No burnout alarm is output, however, when the temperature controller control output is OFF. Burnouts are detected only while the temperature controller control output is being input to the gate input terminals (11 and 12). Faulty outputs do not occur because heater burnout detection is linked with the temperature controller.
- The minimum burnout detection time is 200 ms. Shorter burnouts are not detected.
- Turn ON the voltage fluctuation compensation function (default = OFF) to detect power supply voltage fluctuations and automatically adjust the burnout alarm levels to compensate. Also, turn ON the voltage fluctuation compensation function to detect minor current fluctuations.

Correct Usage

- Always take the control power supply from the primary side of the SSR.
- Use temperature controllers with a 12 or 24-VDC voltage output (30 VDC max.).
- CT1 and CT2 are special products. Use the K8AC-CT□□.
- The CTs do not have polarity.
- Connect only one CT for single-phase heaters. Connect two CTs for three-phase heaters.
- For three-phase heaters, always set the burnout alarm set values for both CT1 and CT2.

Wiring Method When Using the K8AC-H with Contactor Control Heaters

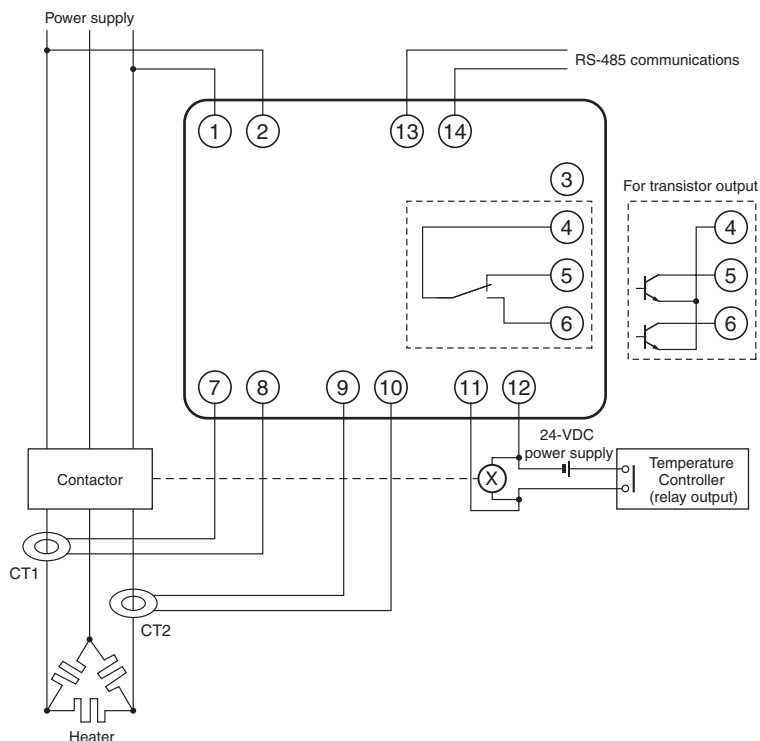

Operation Description

- If the heater current detected at either CT1 or CT2 falls below the burnout alarm set value, an alarm is output. The burnout alarm set value can be set separately for CT1 and CT2. No burnout alarm is output, however, when the temperature controller control output is OFF. Burnouts are detected only while the temperature controller control output is being input to the gate input terminals (11 and 12). Faulty outputs do not occur because heater burnout detection is linked with the temperature controller.
- The minimum burnout detection time is 200 ms. Shorter burnouts are not detected.
- Turn ON the voltage fluctuation compensation function (default = OFF) to detect power supply voltage fluctuations and automatically adjust the burnout alarm levels to compensate. Also, turn ON the voltage fluctuation compensation function to detect minor current fluctuations.

Correct Usage

- Always take the control power supply from the primary side of the contactor.
- Use a temperature controller with relay output.
- The input to the gate input terminals (11 and 12) must be a DC voltage input, so wire the 24-VDC power supply as shown in the diagram to the left.
- CT1 and CT2 are special products. Use K8AC-CT□□.
- The CTs do not have polarity.
- Connect only one CT for single-phase heaters. Connect two CTs for three-phase heaters.
- For three-phase heaters, always set the burnout alarm set values for both CT1 and CT2.

Wiring Method When Using the K8AC-H with Cyclic Control Heaters

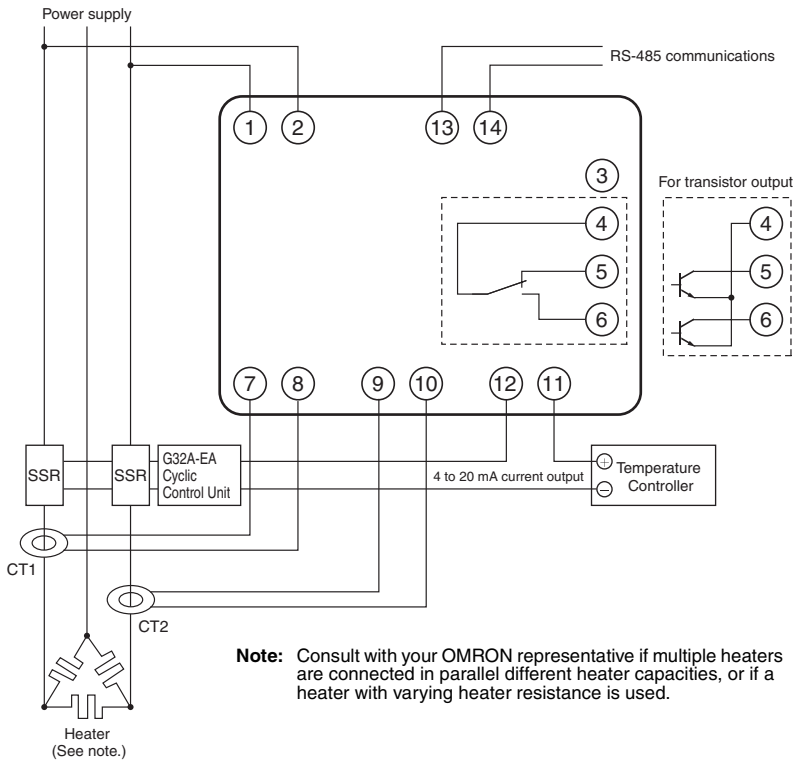

Operation Description

- If the heater current detected at either CT1 or CT2 falls below the burnout alarm set value, an alarm is output. The burnout alarm set value can be set separately for CT1 and CT2. No burnout alarm is output, however, when the temperature controller control output is OFF. Burnouts are detected only while the temperature controller control output is being input to the gate input terminals (11 and 12). Burnout is detected with no errors because the automatic adjustment of burnout alarm level is linked to the temperature controller control output (4 to 20 mA).
- Burnout is detected when control outputs from the temperature controller are 7 mA min.

Correct Usage

- Always take the control power supply from the primary side of the SSR.
- Use a temperature controller with a 4 to 20-mA current output.
- Always adjust the burnout alarm set value when the temperature controller's control output is at 100% (20 mA). The value at 100% output is used as a reference for adjusting burnout alarm levels to compensate for inputs between 4 and 20 mA.
- CT1 and CT2 are special products. Use K8AC-CT□□.
- The CTs do not have polarity.
- Connect only one CT for single-phase heaters. Connect two CTs for three-phase heaters.
- For three-phase heaters, always set the burnout alarm set values for both CT1 and CT2.

Wiring Method When Using the K8AC-H with Phase Control Heaters

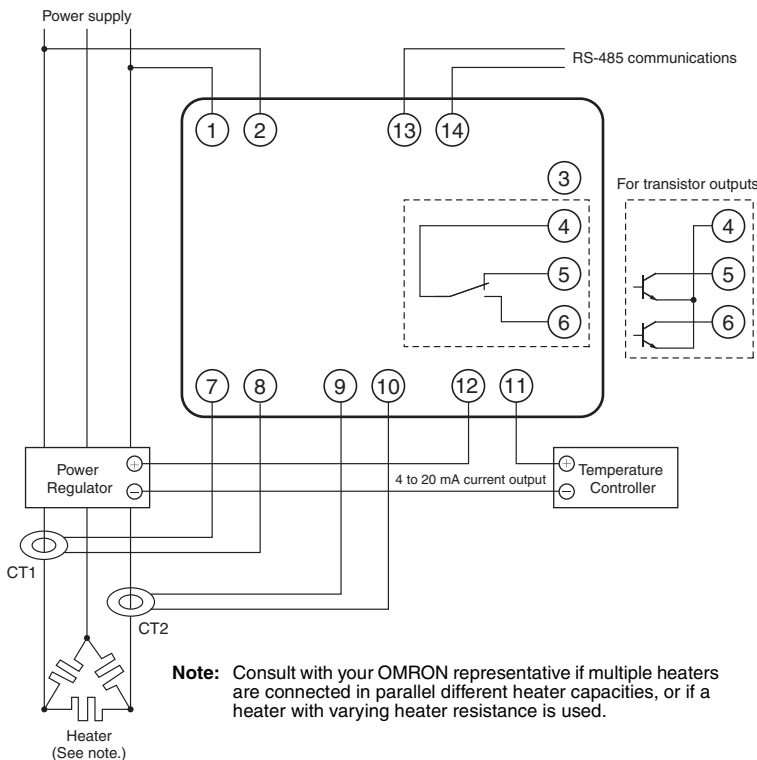

Operation Description

- If the heater current detected at either CT1 or CT2 falls below the burnout alarm set value, an alarm is output. The burnout alarm set value can be set separately for CT1 and CT2. No burnout alarm is output, however, when the temperature controller control output is OFF. Burnouts are detected only while the temperature controller control output is being input to the gate input terminals (11 and 12). Burnout is detected with no errors because the automatic adjustment of burnout alarm level is linked to the temperature controller control output (4 to 20 mA).
- Burnout is detected when control outputs from the temperature controller are 7 mA min.

Correct Usage

- Always take the control power supply from the primary side of the Power Controller.
- Use a temperature controller with a 4 to 20-mA current output.
- Always adjust the burnout alarm set value when the temperature controller's control output is at 100% (20 mA). The value at 100% output is used as a reference for adjusting burnout alarm levels to compensate for inputs between 4 and 20 mA.
- Adjust the burnout alarm set value at a 100% output for gradient settings as well.
- If using the soft startup function with a power regulator, set the soft startup function on the K8AC-H as well, to prevent malfunctions.
- CT1 and CT2 are special products. Use K8AC-CT□□.
- The CTs do not have polarity.
- Connect only one CT for single-phase heaters. Connect two CTs for three-phase heaters.
- For three-phase heaters, always set the burnout alarm set values for both CT1 and CT2.
- When using the power regulator's gradient settings, change the operation gate current level so that the heater current value is within the measurement range. (The initial value is 7 mA.) For details on operating methods, refer to pages 16 to 17.

■ Heater Connection Methods and Current

Depending on the heater connection method, the current when an error occurs will be as shown in the following table. Refer to this table when determining burnout alarm set values.

		Normal condition	Abnormal condition	
Single-phase				
Three-phase	Delta connection			
	Star connection			
	V connection			

Note: This is the current for when a 200-V, 1-kW heater is used for single-phase or three-phase operation.

Rate of Change for Currents with Parallel Heaters

The following table shows the current change ratios when multiple heaters of the same capacity are connected in parallel and one of the heater elements burns out. Use this table for reference when making corrections.
 If five single-phase heaters are connected in parallel, the current change when burnout occurs is 20% per heater.
 If the current for a single heater is low and the change ratio is very slight, it may not be detected. Therefore take into account the detection accuracy for the total current when selecting the number of heaters to be connected in parallel.

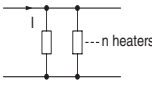
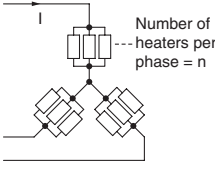
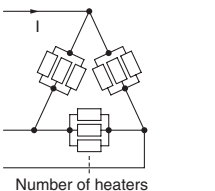
Connection		n=1	n=2	n=3	n=4	n=5
Single-phase 		With one heater burned out, I is 0.	0.5	0.67	0.75	0.8
	Star connection 	Current in burned-out phase	With one heater burned out, I is 0.	0.6	0.75	0.82
Delta connection 		Current in other phases	0.87	0.92	0.95	0.97
		Current in lines near burned-out phase (Same as 2-phase.)	0.58	0.77	0.84	0.88
	Current in other phases	1	1	1	1	1

- Note:**
- The figures in the above table show the current change ratios when burnout occurs for one heater connected in parallel.
 - The numbers represent the current ratio after one heater burns out, with the current prior to the burnout (i.e., the normal current) taken as 1.
 - In actual operation there may be effects from factors such as load (heater) imbalances, so conduct an actual test for confirmation before making adjustments if the current change ratio between normal and abnormal operation is slight.
 - Consult with your OMRON representative if multiple heaters are used with different heater capacities.

Operation

Main K8AC-H Functions

The K8AC-H is a digital heater burnout detector that detects heater burnout by measuring the heater current from various power supply systems.
 The K8AC-H provides the following functions.

Applicable Heater Control Methods

The following heater control methods can be used.

ON/OFF Control (Contactor/SSR)

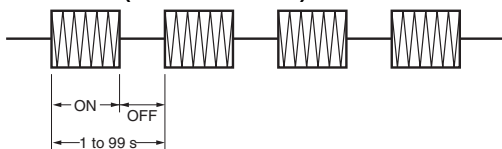

Cyclic Control

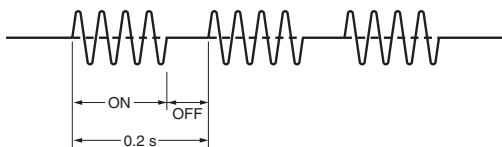

Phase Control (Applicable to 4 to 20 mA Current-output temperature controllers)

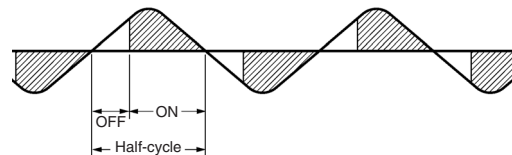

Heater Burnout Alarm

The preset burnout detection value is compared with the heater current and an alarm is output accordingly.

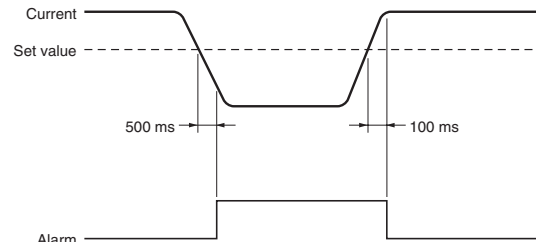

Transistor output models: ALM indicator lit, ALM transistor output
 Relay output models: ALM indicator lit, OR of all detection status output

Error Detection

The following errors are detected according to status. Heater layer short errors are detected (overcurrent detection). The preset overcurrent detection set value is compared with the heater current and an alarm is output accordingly.

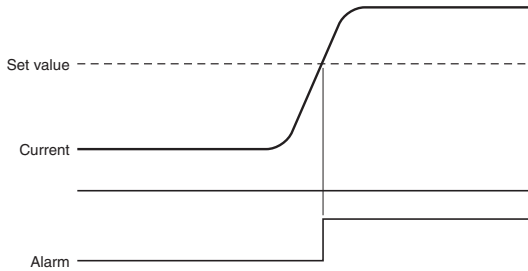

Transistor output models: ALM indicator lit, ALM transistor output
Relay output models: ALM indicator lit, OR of all detection status output

SSR Short Circuit Detection

If current is measured when there is no gate input, an SSR short circuit error is detected and an alarm is output.

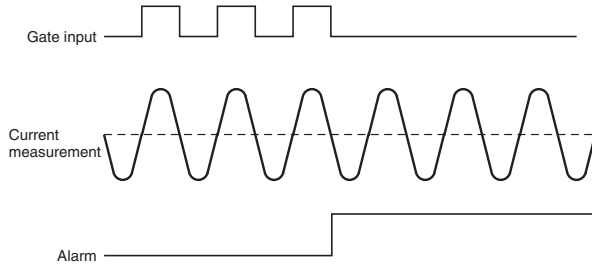

Transistor output models: SSR indicator lit, SSR transistor output
Relay output models: SSR indicator lit, OR of all detection status output

SSR Open Circuit Detection

If current is not measured during gate input, an SSR open circuit error is detected and an alarm is output.

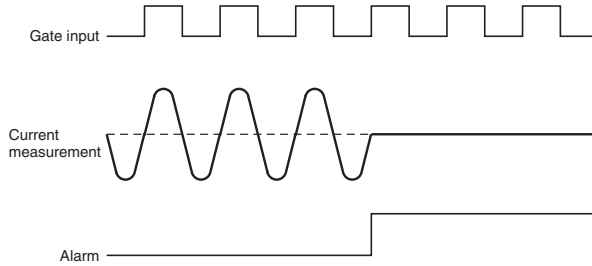

Transistor output models: SSR indicator lit, SSR transistor output
Relay output models: SSR indicator lit, OR of all detection status output

Voltage Fluctuation Compensation

The voltage fluctuation compensation function automatically adjusts the burnout alarm operation level of the K8AC-H depending on voltage fluctuations in the heater circuit.

The operating value for burnout detection when multiple heaters are connected is set very close to the normal value. Thus, a false burnout alarm output will occur if there is a voltage drop in the heater circuit.

The voltage fluctuation compensation function prevents this type of false output.

Example: Voltage Drop from 100 V to 95 V in the Heater Circuit

Conditions:

Voltage fluctuation compensation standard value = 100 V
Burnout alarm set value = 10.0 A

If the power supply voltage drops from 100% to 95%, the operating value will also be reduced from 100% to 95%.
Burnout alarm operating value = 10.0 A × 95% = 9.5 A

Gate Input

The gate input provides a sync signal used to link burnout detection to the control output of the temperature controller.

For SSR control, the voltage output pulse from the temperature controller is input.

For contactor control, 24 VDC linked to a relay contact of the temperature controller is input.

For cyclic or phase control, a 4 to 20-mA control signal is input.

If there is no gate input for a Heater Element Burnout Detector, a heater burnout alarm would be falsely output when the voltage output pulse from the temperature controller turns OFF, and there would be no way to tell whether it was a false output.

Note: The gate input function can be disabled. If it is disabled, Heater Element Burnout Detector operation will not be linked to the temperature controller control signal. (The gate input can be used as a simple undercurrent detection relay.)

Power-saving Operation

If there are no key operations performed within a preset time period, the display automatically turns OFF.

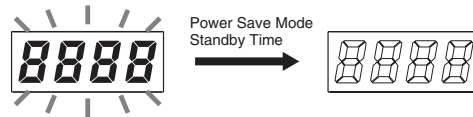

Output Operation Time Charts

Heater Burnout and Heater Layer Short (Overcurrent) Alarms

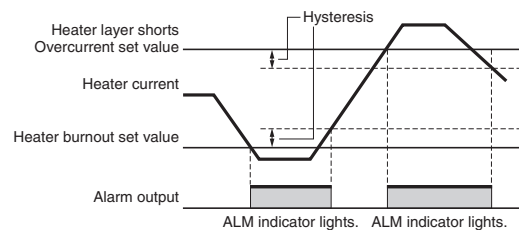

SSR Short/Open Circuit Alarm

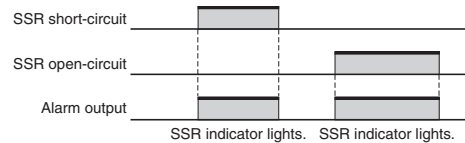

Using the Power Regulator's Gradient Settings

The power regulator's gradient settings can be used to prevent malfunction by setting the operation gate current level. The relationship between the gradient settings and output current depends on the power regulator manufacturer and model, so be sure to check the characteristics of the power regulator being used before setting.

Setting Example

Initial setting: 7 mA

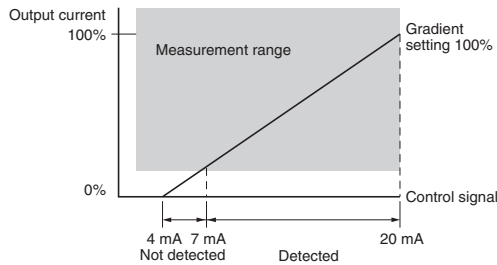

When the power regulator's gradient settings are changed, the operation gate current level is set so that the output current is within the measurement range. (In the following diagram, 14 mA is set.)

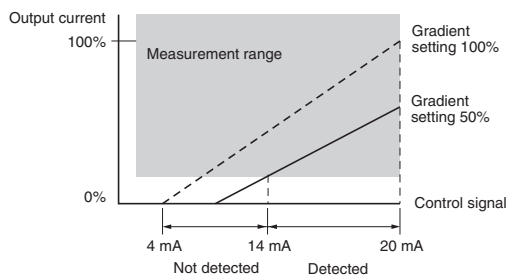

Using Halogen or Other Heaters with Varying Resistance during Phase and Cyclic Control

When phase control is used with halogen heaters or other pure metal heaters, the heater resistance fluctuates according to the control level. As a result, high-precision detection of heater burnout is not possible. The effect on the heater and setting methods depends on the heater being used. Therefore, consult with your OMRON representative before using a heater with varying resistance values.

Halogen Heater Resistance Fluctuation Example

In the following example, burnout of one element in a six-element heater can be detected at a control level of 20 mA, but detection is not possible due to the effect of fluctuating resistance if the control level is any lower.

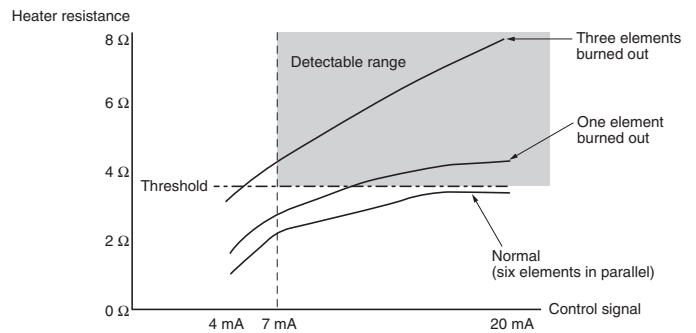

Nomenclature

■ Nomenclature and Operations

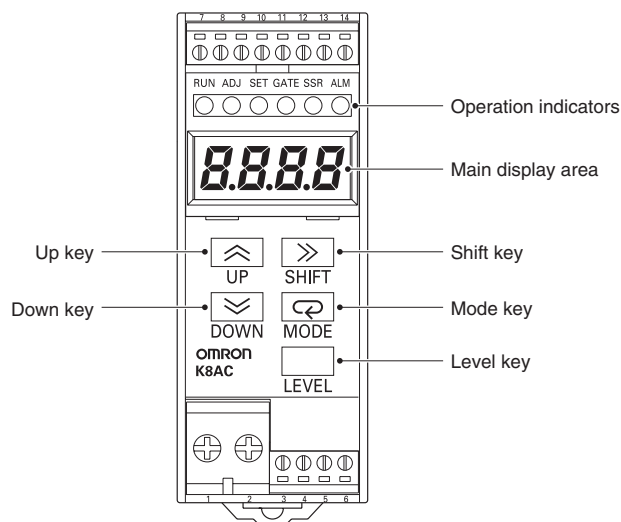

Name		Operation
Main display		Displays processing values, parameter characters, and set values.
Operation indicators	RUN (Measurement operation)	Lights when the power is turned ON and the measurement operation is in progress. OFF at all other times.
	ADJ (Adjust)	Lights while in adjust mode. Flashes while in test mode. OFF at all other times.
	SET (Set)	Lights while in set mode. OFF at all other times.
	GATE (Gate)	Lights or turns OFF according to gate input status. Gate pulse: Lights for high voltage pulse; OFF for low voltage pulse. Gate linear: Lights for 4 mA or over; OFF for less than 4 mA.
	SSR (SSR error) (See note.)	Lights when an SSR error occurs (open or short circuit). OFF when SSR is normal.
	ALM (Alarm) (See note.)	Lights for heater burnout or overcurrent. OFF at all other times.
Up key		Increments a set value when the set value is in change status.
Down key		Decrements a set value when the set value is in change status.
Shift key		Used to check set values while parameters are displayed, and to put set values in change status. Used to shift the set value digit when the set value is in change status.
Mode key		Used to switch the displayed parameter.
Level key		Used to change the level.

Note: Check the specific status using the alarm display parameters on the main display.

Alarm Indicators

Order of priority	Alarm	7-segment display characters	LED indicator	Alarm contents
1	Heater burnout 1	HbE 1	ALM indicator lit	CT1 heater burnout detected.
2	Heater burnout 2	HbE 2	ALM indicator lit	CT2 heater burnout detected.
3	SSR open circuit	SS-o	SSR indicator lit	SSR open circuit detected (when heater current cannot be detected with temperature control gate output ON).
4	SSR short circuit	SS-S	SSR indicator lit	SSR short circuit detected (when heater current is detected with temperature control gate output OFF).
5	Heater layer short 1	Hr-S 1	ALM indicator lit	CT1 overcurrent detected.
6	Heater layer short 2	Hr-S 2	ALM indicator lit	CT2 overcurrent detected.

- Note:**
- As soon as the cause of an alarm is removed, the alarm is reset automatically.
 - If multiple alarms occur simultaneously, the one with the highest priority is displayed.
 - If the mode is changed to ADJ or SET mode while an alarm is in effect, the alarm output is reset and the ALM and SSR indicators turn OFF.

Processing Value Display Ranges and Functions

Processing value name	Display characters	Display range	Unit	Function
Heater 1 current	E E 1	0100 to 2300 (See notes 1 and 2.)	A	This is the CT1 heater current processing value. Alarm operations such as the heater burnout alarm are determined based on this processing value.
Heater 2 current	E E 2	0100 to 2300 (See notes 1 and 2.)	A	This is the CT2 heater current processing value. Alarm operations such as the heater burnout alarm are determined based on this processing value.

- Note:**
- The decimal point position depends on the input type.
 K8AC-H□1□□: 0.100 to 2.300
 K8AC-H□2□□: 1.00 to 23.00
 K8AC-H□3□□: 10.0 to 230.0
 - If the display is below 0100, the bar display "----" will be shown.

■ Settings Method

Settings Methods for SSR and Contactor Control Heaters

Setting Conditions

Detecting burnouts in just one heater when ten 300-W rated heaters are connected in parallel to a single-phase 200-V power supply.

The heater is SSR controlled.

Normal Heater Current and Heater Current with One Heater Element Burnout

Normal current = $(300\text{ W} \times 10 \text{ (heaters)})/200\text{ V} = 15.0\text{ A}$

Current with one burnout = $(300\text{ W} \times 9)/200\text{ V} = 13.5\text{ A}$

$$\text{Heater burnout alarm set value} = \frac{(\text{Normal current} + \text{current at malfunction})}{2} = \frac{15.0+13.5}{2} = 14.3\text{ A}$$

Selecting Heater Element Burnout Detector Models

For the above example, K8AC-H12C□-FLK would be selected. The burnout alarm set value is 14.3 A, so the current range 2.00 to 22.00 A should be selected.

SSR control is used, so type C should be selected. (Type C is also selected for contactor control.)

Select the appropriate relay or transistor output specifications, depending on the application.

K8AC-H Parameter Setting Procedure

(Only the minimum settings are shown here. Refer to pages 16 to 19 for information on how to set parameters.)

1. Turn ON the power to the K8AC-H. The initial status when power is turned ON is called RUN mode.
2. Press the Key for at least 3 s to change from RUN mode to ADJ mode (the mode for adjusting burnout alarm set values.)
3. Set the burnout alarm set values. (AL-1 = CT1 burnout alarm set value and AL-2 = CT2 burnout alarm set value.)
Set "14.3" to AL-1.
Set the AL-2 burnout alarm set value to "----" so that it will not detect heater burnout, because this is a single-phase heater.
4. Change to RUN mode.
Press the Key while in ADJ mode for at least 1 s to change to RUN mode.
5. Check operation.
Test heater burnout detection by burning out one heater. Also check that there are no malfunctions during temperature control.

Note: The default setting for functions including the voltage fluctuation compensation function, hysteresis, output ON delay time, and SSR error detection function is OFF. Turn ON any of these functions as required.

Settings Method for Cyclic and Phase Control Heaters

Settings Conditions

Detecting burnouts in one heater when five 1,000 W-rated heaters are connected to each phase of a three-phase delta-connected 200-V power supply.

A power regulator (phase control) performs heater control.

Normal Heater Current and Heater Current With One Heater Element Burnout

Normal current = $(1,000\text{ W} \times 5 \text{ (heaters)})/200\text{ V} = 43.3\text{ A}$

Current with one burnout = $(1,000\text{ W} \times 4)/200\text{ V} = 39.1\text{ A}$

$$\text{Heater burnout alarm set value} = \frac{\text{Normal current} + \text{current at malfunction}}{2} = \frac{43.3+39.1}{2} = 41.2\text{ A}$$

Selecting Heater Element Burnout Detector Models

For the above example, K8AC-H13P□-FLK would be selected. The burnout alarm set value is 41.2 A, so the current range 20.0 to 200.0 A should be selected.

Phase control is used, so type P should be selected. (Type P is also selected for cyclic control.)

Select the appropriate relay or transistor output specifications, depending on the application.

K8AC-H Parameter Settings Procedure

(Only the minimum settings are shown here. Refer to pages 16 to 19 for information on how to set parameters.)

1. Turn ON the power to the K8AC-H. The initial status when power is turned ON is called RUN mode.
2. Press the Key for at least 3 s to change from RUN mode to ADJ mode (the mode for adjusting burnout alarm set values.)
3. Change from ADJ mode to SET mode (the default settings mode for all functions). The password "0169" is required to move to SET mode.
4. Set the heater control method parameter to PH-3 (three-phase control).
The default setting is PH-1 (single-phase control).
Note: Set the parameter to CYCL (cyclic control) when using cyclic control.
5. Press the Key for at least 1 s to change from SET mode to ADJ mode. Press the Key again for at least 1 s to change from ADJ mode to RUN mode.

Note: The default setting for functions including the voltage fluctuation compensation function, hysteresis, output ON delay time, and SSR error detection function is OFF. Turn ON any of these functions as required.

Burnout Alarm Set Value Setting Method

Setting Method

- Wire the K8AC-H, temperature controller (4 to 20 mA current output type), and power regulator (phase control).
- Press the Key on the K8AC-H for at least 3 s to change from RUN mode to ADJ mode.
- AL-1 (CT1 burnout alarm set value) will be displayed when the mode is changed to ADJ mode. Press the key once when AL-1 is displayed. Next, press the Key once. The present heater current value will be displayed on the main display, so note this as the normal current value. Always have the temperature controller output at 20.0 mA at this time. (See note 1.)
- Next, disconnect one heater and note the heater current in this burnout state. Alternatively, use the current when one heater is burned out (calculated earlier) as the current during malfunction. It is recommended that the current at an actual burnout is confirmed.

- Set the K8AC-H burnout alarm set value based on the results. The burnout alarm set value is set at the mid-point between the normal current and the current at malfunction, taking errors and variations in heater capacity into consideration.
- In this setting example, the set value for AL-2 (CT2 burnout alarm setting) is the same as the set value for AL-1. (See note 2.)

- Note:**
1. The K8AC-H automatically adjusts burnout alarm setting levels to compensate based on the temperature controller current output. The burnout alarm set value must be set when the temperature controller output is at 100% (20 mA), so be sure to have the temperature controller at 20 mA output.
 2. If the heater capacity is unbalanced, the CT1 and CT2 burnout alarm levels may not be at the same value.

■ Measurement Monitor Value Display Ranges and Functions

Other than measuring the heater current, the K8AC-H can measure the power supply voltage, maximum/minimum current, maximum/minimum voltage, and other values. The measurement data can be monitored from a host using RS-485 communications. The measurement monitor value names, display ranges, and functions are given in the following table.

Measurement monitor value name	Display characters	Display range	Unit	Function
Power supply voltage	5E E	0085 to 0264	V	This is the K8AC-H control power supply voltage. When the voltage fluctuation compensation function is enabled, the heater burnout determination based on this voltage is automatically compensated.
Heater 1 maximum current (See note.)	hR h i	0100 to 2300	A	These hold the maximum and minimum values for each processing value. <ul style="list-style-type: none"> • The maximum and minimum heater currents after the power is turned ON or after a maximum or minimum reset are displayed. • The values are not saved when power is interrupted. • The current values are not refreshed when startup lock is in effect and when the gate input is enabled but the gate input is OFF. • Power supply voltages are always refreshed.
Heater 1 minimum current (See note.)	hL h i	0100 to 2300	A	
Heater 2 maximum current (See note.)	hR h 2	0100 to 2300	A	
Heater 2 minimum current (See note.)	hL h 2	0100 to 2300	A	
Maximum power supply voltage (See note.)	hR h 5	0085 to 0264	V	
Minimum power supply voltage (See note.)	hL h 5	0085 to 0264	V	
Number of alarm outputs	R h t	0000 to 9999	Outputs	
Processing value for alarm output	hE h o	0100 to 2300	A	This holds the CT1 or CT2 processing value when a heater burnout alarm is output. <ul style="list-style-type: none"> • This is the most recent processing value, and it is refreshed each time a heater burnout alarm occurs. • The value is not saved when power is interrupted.
Run time	o h h	0000 to 9999	× 10h	This is the total run time value from when power is turned ON or the processing value is reset until an alarm occurs. <ul style="list-style-type: none"> • The total time is recorded in non-volatile memory approximately once per hour. If power is interrupted within the hour, however, the data since the beginning of the hour is lost and the total starts over from when the time was last saved. • The total is stopped during heater burnout alarm output. When the alarm is cleared, the total resumes from the time just before the alarm occurred.
Heater 1 input shift display current	hS h i	-999 to 999	A	This is the shift value for displaying the CT1 heater current measurement set in measurement parameter CT1. <ul style="list-style-type: none"> • The value is saved when power is interrupted.
Heater 2 input shift display current	hS h 2	-999 to 999	A	This is the shift value for displaying the CT2 heater current measurement set in measurement parameter CT2. <ul style="list-style-type: none"> • The value is saved when power is interrupted.

Note: Each measurement monitor value can be individually reset. Refer to the *K8AC-H Digital Heater Element Burnout Detector User's Manual* (Cat. No. N132) for operating procedures.

■ Modes

Groups of setting items are called “modes.” The K8AC-H has five modes.

Mode	Function	Alarm operation
RUN	This is the normal operating mode, used for receiving inputs, executing heater burnout outputs, etc. Operation goes into RUN mode immediately after power is turned ON.	Executed
ADJ	This mode is used to change comparatively frequently set parameters, such as alarm value settings. This also the mode for entering the password to move to the SET mode.	Stopped
SET	This mode is used to make the initial settings for the various functions.	Stopped
Protection Settings	This mode is used to make settings to prevent unintended key operations. The protected modes are not displayed, preventing changes to set values.	Stopped
TEST	This mode is used to simulate inputs with key operations to test alarm outputs.	Executed
GATE	This mode sets the gate current value that stops an alarm or detection.	Executed

Note: If more than five minutes elapses with no operations performed in the Protection Settings mode, ADJ mode, or SET mode, the status will return automatically to the processing value display. If this occurs while settings are in progress, it may cause unintended operations in the processing value display. Be careful not to allow this to happen.

■ Settings Data Notation

The letters of the alphabet in settings data are displayed as shown below.

A	b	C	d	E	F	G	H	I	J	K	L	M	N	O	P	q	r	S	t	U	v	y	z	;	
A	B	C	D	E	F	G	H	I	J	K	L	M	N	O	P	Q	R	S	T	U	V	W	X	Y	Z

Operating Procedures

Moving between Modes

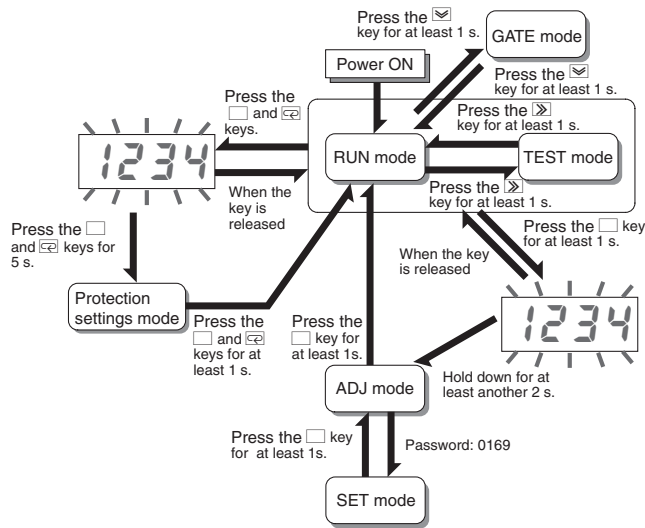

To ADJ Mode

When the key is pressed for one second in RUN mode, the 7-segment display will begin to flash. If the key is held down for another two seconds, the mode will be switched to ADJ mode.

To return to RUN mode from ADJ mode, press the key for at least one second.

To Protection Settings Mode

When the and keys are pressed for one second in RUN mode, the 7-segment display will begin to flash. If the keys are held down for another five seconds, the mode will be switched to Protection Settings mode. To return to RUN mode from Protection Settings mode, press and keys for at least one second.

To GATE Mode

When the key is pressed for at least one second in RUN mode, the mode will be switched to GATE mode. To return to RUN mode from GATE mode, press the key for at least one second.

To TEST Mode

When the key is pressed for at least one second in RUN mode, the mode will be switched to TEST mode. To return to RUN mode from TEST mode, press the key for at least one second.

To SET Mode (Password Input)

A special operation is required to move to the SET mode. Use the following procedure.

Procedure

- Move to the ADJ mode and use the key to display the parameter for moving to the SET mode.
 - The parameter characters are "Añõu".
- Press the key to display the set value (password).
- Press the key again to enable changing the password.
- Use , , and keys to set the password. The password is 0169.

- Press the key.
- If the password is correct, the mode will change to the SET mode.
- If the password is incorrect, the next parameter will be displayed while still in ADJ mode.

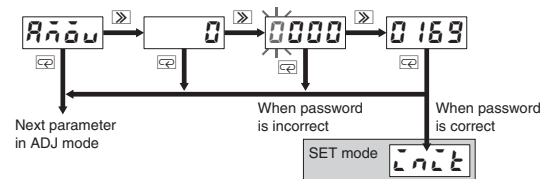

Setting the Parameter

The value set for each parameter is called the "set value." Set values include both numbers and characters.

The status when a set value is displayed is called "monitor status," and when it can be changed it is called "change status."

Use the following procedure to display and change set values.

Procedure

- Press the key while a parameter is displayed to go into monitor status. The set value for that parameter will be displayed.
- If the set value is not to be changed, press the key while in monitor status to switch to the next parameter.
- Press the key again while in monitor status to enable the changing set value.
 - The place where the set value can be changed will begin to flash.
- Use the , , and keys to change the set value.
- Press the key to save the changed set value in internal memory and switch to the next parameter.

- Changed set values will not be saved in memory if the mode is changed by another key operation without first pressing the key.

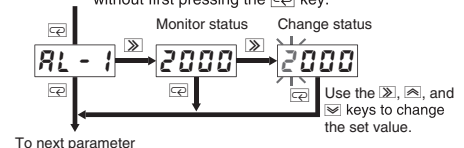

Note:

If a set value is out of range, either too high or too low, the maximum or minimum value will automatically be set. For models with a current input of 0.200 to 2.200 A, for example, the maximum value is 2.200 and the minimum value is 0.200.

Parameter List

The setting items in each mode are called "parameters." Parameters can be switched by using the  key.

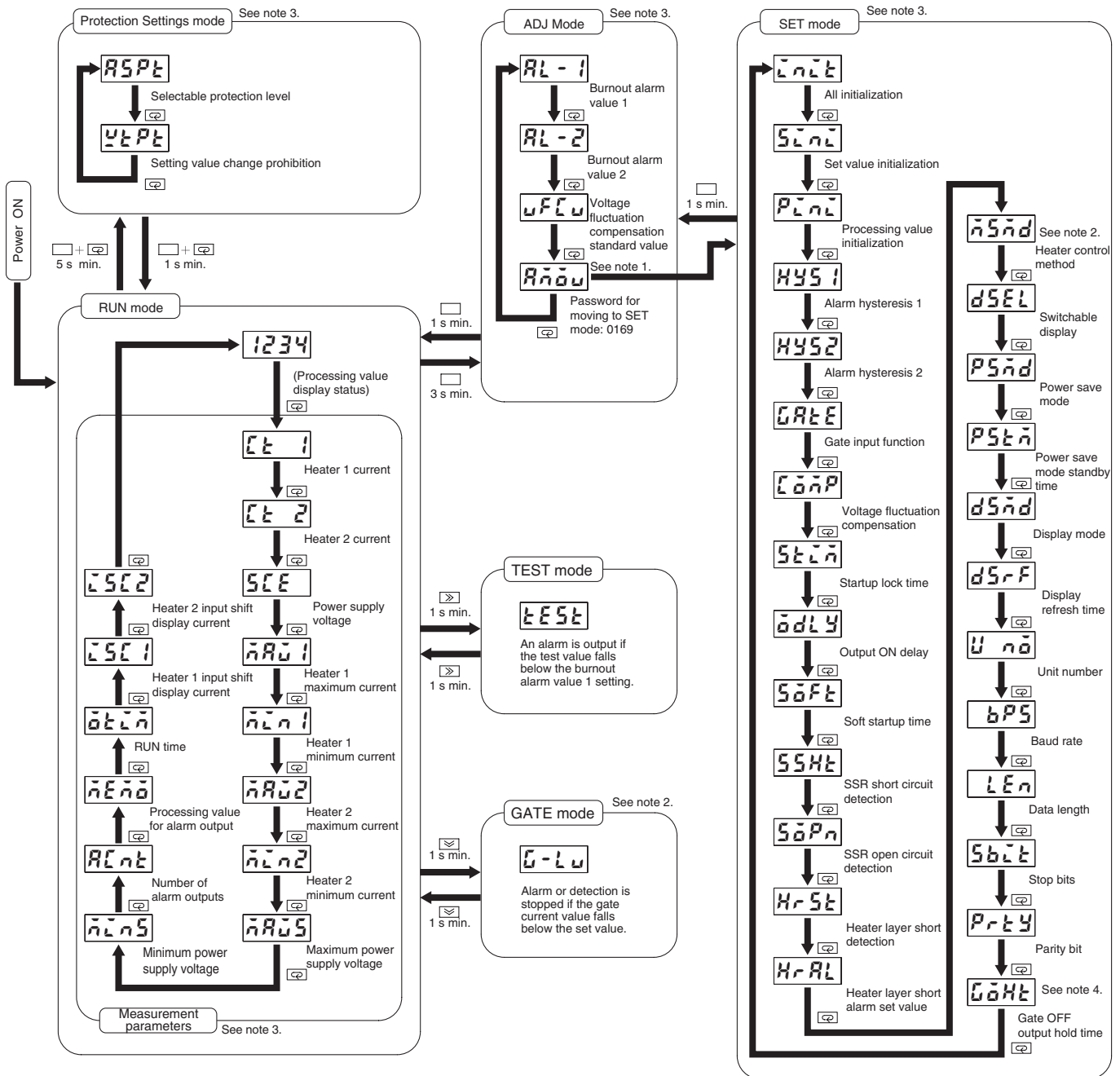

- Note:**
1. Displayed when the Selectable Protection Level parameter is set to 0.
 2. Displayed by the K8AC-H□□P□-FLK.
 3. If more than five minutes elapses with no operations performed in Protection Settings mode, ADJ mode, SET mode, or for a measurement parameter, the status will return automatically to the processing value display. If this occurs while settings are in progress, it may cause unintended operations to be performed in the processing value display. Be careful not to allow this to happen.
 4. Displayed by the K8AC-H□□C□-FLK.

Parameter Defaults and Descriptions

Note: Shaded parameters must always be set regardless of the measurement method.

Item Mode	Parameter name	Description	Parameter	Setting range	Default	
Protection Settings	Selectable Protection Level	Restrict access to Adjust Mode (ADJ) and or Setting Mode (SET) from RUN mode. 0: Access enabled to both ADJ and SET. 1: Access enabled to ADJ and disabled to SET. 2: Access disabled to both ADJ and SET.	PSPL	0 to 2	0	
	Setting Value Change Prohibition	Prohibits changes to set values.	SPPL	ON/OFF	OFF	
ADJ	Burnout Alarm Value 1	K8AC-H□1	Sets the output operation value for the burnout alarm. Note: The burnout alarm function can be disabled by setting the set value to “-”.	RL-1	0.200 to 2.200 A	1.000 A
		K8AC-H□2		2.00 to 22.00 A	10.00 A	
		K8AC-H□3		20.0 to 200.0 A	100.0 A	
	Burnout Alarm Value 2	K8AC-H□1	Sets the output operation value for the burnout alarm. Note: The burnout alarm function can be disabled by setting the set value to “-”.	RL-2	0.200 to 2.200 A	1.000 A
		K8AC-H□2		2.00 to 22.00 A	10.00 A	
		K8AC-H□3		20.0 to 200.0 A	100.0 A	
	Voltage Fluctuation Compensation Standard Value	Sets the standard voltage used by the voltage fluctuation compensation function. The fluctuation compensation function operates in respect to this set value.	VFLV	100 to 240 VAC	100 V	
	SET	All Initialization	Returns all set values and measurement values to their default settings.	INIZ	ON/OFF	OFF
		Set Value Initialization	Returns all set values to their default settings.	SVIZ	ON/OFF	OFF
Processing Value Initialization		Returns all measurement values to their default settings.	PVIZ	ON/OFF	OFF	
Alarm Hysteresis 1		Sets hysteresis for the alarm output value for burnout detection (undercurrent) and heater layer shorts (overcurrent) for CT1.	HY51	1 to 999	10	
Alarm Hysteresis 2		Sets hysteresis for the alarm output value for burnout detection (undercurrent) and heater layer shorts (overcurrent) for CT2.	HY52	1 to 999	10	
Gate Input Function		Turns the gate input function ON and OFF. If the gate input is turned OFF, application as a simple ammeter is possible.	GRIF	ON/OFF	ON	
Voltage Fluctuation Compensation		Turns the voltage fluctuation compensation function ON and OFF.	VFLV	ON/OFF	OFF	
Startup Lock Time		Sets the lock time for the startup lock.	SLTN	0 (OFF) to 255 s	0 (OFF)	
Output ON Delay		Sets the output delay time. Set this parameter to set the operating time.	ODLY	0.0 (OFF) to 99.9 s	0.0 (OFF)	
Soft Startup Time		Sets the soft startup time. Set this parameter only when using a soft start function with the power regulator.	SSTF	0.0 (OFF) to 99.9 s	0.0 (OFF)	
SSR Short Circuit Detection		Turns the SSR short circuit detection function ON and OFF.	SSMC	ON/OFF	OFF	
SSR Open Circuit Detection		Turns the SSR open circuit detection function ON and OFF.	SSPC	ON/OFF	OFF	
Heater Layer Short Detection (Overcurrent Detection)		Turns the heater layer short (overcurrent) detection function ON and OFF.	HLSD	ON/OFF	OFF	
Heater Layer Short Alarm Level (Overcurrent Alarm Set Value)		K8AC-H□1	Sets the operating level for heater layer short (overcurrent) alarms. Note: The heater layer short alarm level is the same for both CT1 and CT2.	HLAL	0.200 to 2.200 A	2.000 A
		K8AC-H□2		2.00 to 22.00 A	20.00 A	
		K8AC-H□3		20.0 to 200.0 A	200.0 A	
Heater Control Method (See note 1.)		Sets the control method of the cyclic/phase control heater.	HSCM	PH1, PH3, CYCL	PH1	
Switchable Display		Sets the CT for which to normally display the current.	SDIS	CT1, CT2	CT1	
Power Save Mode		Turns entering the power save mode ON and OFF.	PSMD	ON/OFF	OFF	

Item	Parameter name	Description	Parameter	Setting range	Default
Mode	Power Save Mode Standby Time	Sets the time to enter power save mode.	PS _{ST}	10 to 300 s	60 s
	Display Mode	Sets a 7-segment (NORM), full-span comparison (CMP), or bar (BAR) display.	d _{SM}	NORM, CMP, BAR	NORM
	Display Refresh Time	Sets the refresh time for the display.	d _{SRF}	0.2 s, 0.5 s, 1.0 s, FAST	0.5 s
	Unit Number	Sets the unit number for RS-485 communications.	U _{NO}	0 to 64	0
	Baud Rate	Sets the baud rate for RS-485 communications.	d _{PS}	1200, 2400, 4800, 9600, 19200	9600
	Data Length	Sets the data length for RS-485 communications.	L _{EN}	7, 8	7
	Stop Bits	Sets the number of stop bits for RS-485 communications.	S _{BT}	1, 2	2
	Parity Bit	Sets the parity for RS-485 communications.	P _{RTY}	EVEN, ODD, NONE	EVEN
	Gate OFF output hold time (See note 2.)	Sets the time from when the gate signal goes OFF until the burnout alarm output turns OFF.	G _{OH}	0 to 999 s	2 s
GATE	Operation gate current level (See note 1.)	G _{IL}	7.0 to 20.0 mA	7.0 mA	

Note: 1. Displayed by the K8AC-H□□P□-FLK.
 2. Displayed by the K8AC-H□□C□-FLK.

Dimensions

Note: All units are in millimeters unless otherwise indicated.

Digital Heater Element Burnout Detectors

K8AC-H

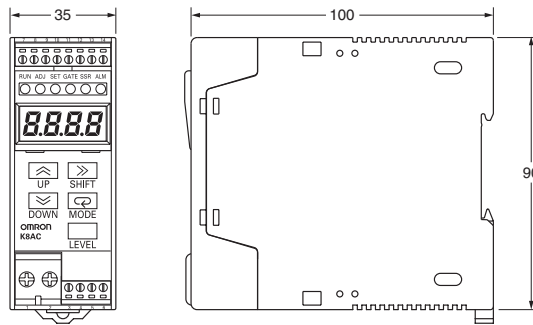
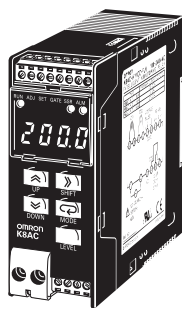

Optional Parts (Order Separately)

Current Transformer

K8AC-CT20S

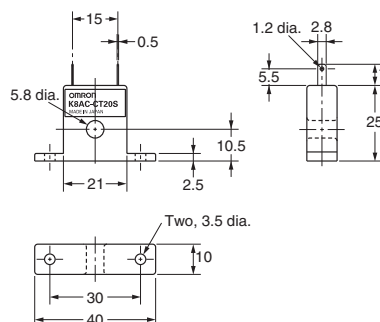

Current Transformer

K8AC-CT20L

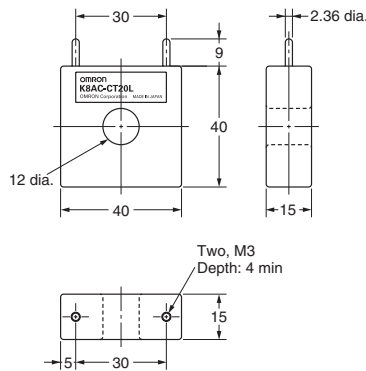

Accessories with K8AC-CT20L: Connection Example

• Contact

Approx. 3 dia.

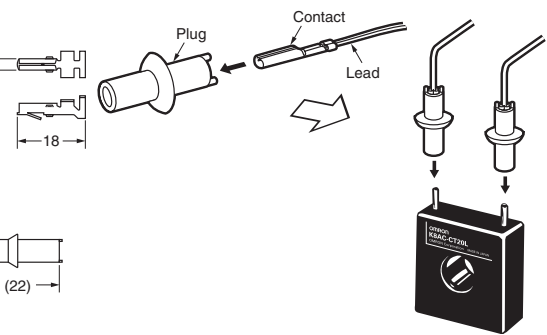

• Plug

Approx. 6 dia.

Current Transformer

K8AC-CT200 (Pre-wired Leads)

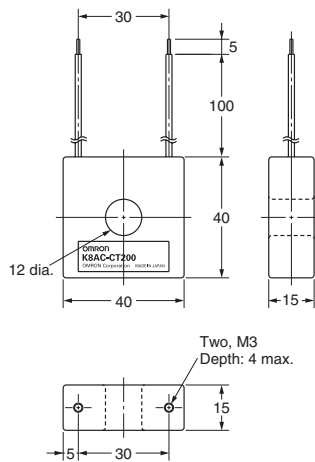

Current Transformer

K8AC-CT200L

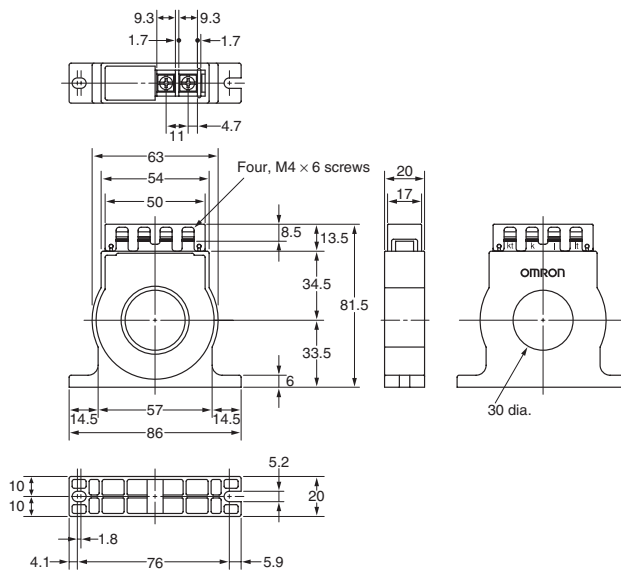

Mounting Hole Dimensions

Two, M5 screw holes or two, 5.5-dia. holes

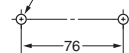

Recommended Tools

Recommended Flat-blade Screwdriver

Manufacturer: Phoenix Contact

Model number: SZS0.4 × 2.5

Crimper for Bar Terminals (Crimping Tool)

Manufacturer: Phoenix Contact

Model number: CRIMPF0X UD6

Recommended power line diameters: AWG10 to AWG24

Recommended Crimp Terminals

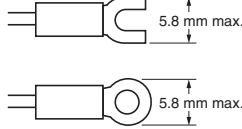
Terminals	Recommended crimp terminals	Recommended wire gauge
1 and 2	M3 crimp terminals (Width: 5.8 mm max.) 	AWG16 to AWG18
4 to 14	M2 bar terminals: AI 0.34-8TQ (Phoenix Contact)	AWG22
	M2 bar terminals: AI 0.5-8WH (Phoenix Contact)	AWG20
	M2 bar terminals: AI 0.75-8GY (Phoenix Contact)	AWG18
	M2 bar terminals: AI 1-8RD (Phoenix Contact)	AWG18

Note: Securely tighten the terminal screws to the following torque
 Power supply terminals: 0.5 N·m
 I/O terminals: 0.23 N·m

Precautions

Precautions for Safe Use

The following precautions are essential to ensure safety. Always heed these precautions.

- Do not use or store the Product in the following locations.
 - Outdoors or in locations subject to direct sunlight, wind, or rain
 - Locations subject to dust, metal powder, or corrosive gases (in particular, sulfuric or ammonia gas)
 - Locations subject to static electricity or noise
 - Locations subject to flooding or exposure to oil
- Use DIN Track for installation and mount the Product in the correct direction.
- Do not touch the terminals when power is being supplied. Electric shock may occasionally occur.
- Be sure you understand the contents of the Instruction Sheet and User's Manual and handle the Product according to the instructions provided.
- Check all terminal numbers and polarity when wiring and wire all connections correctly.
- Tighten terminal screws to the following torque.
 - Power supply terminals: 0.5 N·m
 - I/O terminals: 0.23 N·m
- Use the Product within the specified temperature and humidity ranges.
- Do not use the Product in locations subject to flammable or explosive gases. Explosions may occasionally occur if the Product is used in such locations.
- Do not install the Product in any way that would place a load on it.
- Use only the CTs specified by OMRON.
- Be sure to install the Product in a panel designed so that fire cannot escape to the exterior of the panel.
- Install an external switch or circuit breaker that complies with applicable IEC60947-1 and IEC60947-3 requirements and label it clearly so that the operator can quickly turn OFF the power.

Related Products



Heater Element Burnout Detector **K2CU**

Enables detection of single-phase/three-phase burnouts. For heaters with ON/OFF control only, provides voltage fluctuation compensation.

Rated current: 0.25 to 80 A AC



Current Sensor **SAO**

Enables detection of single-phase/three-phase overcurrents. Inverse operation models and instantaneous operation models (with startup lock) are available.

Rated current: 1 to 160 A AC

For details, refer to the Measuring & Motor Protective Relays Group Catalog (Cat. No. X070).

- The application examples provided in this catalog are for reference only. Check functions and safety of the equipment before use.
- Never use the products for any application requiring special safety requirements, such as nuclear energy control systems, railroad systems, aviation systems, medical equipment, amusement machines, vehicles, safety equipment, or other application involving serious risk to life or property, without ensuring that the system as a whole has been designed to address the risks, and that the OMRON products are properly rated and installed for the intended use within the overall equipment or system.

Terms and Conditions of Sale

1. **Offer; Acceptance.** These terms and conditions (these "Terms") are deemed part of all quotes, agreements, purchase orders, acknowledgments, price lists, catalogs, manuals, brochures and other documents, whether electronic or in writing, relating to the sale of products or services (collectively, the "Products") by Omron Electronics LLC and its subsidiary companies ("Omron"). Omron objects to any terms or conditions proposed in Buyer's purchase order or other documents which are inconsistent with, or in addition to, these Terms.
2. **Prices; Payment Terms.** All prices stated are current, subject to change without notice by Omron. Omron reserves the right to increase or decrease prices on any unshipped portions of outstanding orders. Payments for Products are due net 30 days unless otherwise stated in the invoice.
3. **Discounts.** Cash discounts, if any, will apply only on the net amount of invoices sent to Buyer after deducting transportation charges, taxes and duties, and will be allowed only if (i) the invoice is paid according to Omron's payment terms and (ii) Buyer has no past due amounts.
4. **Interest.** Omron, at its option, may charge Buyer 1-1/2% interest per month or the maximum legal rate, whichever is less, on any balance not paid within the stated terms.
5. **Orders.** Omron will accept no order less than \$200 net billing.
6. **Governmental Approvals.** Buyer shall be responsible for, and shall bear all costs involved in, obtaining any government approvals required for the importation or sale of the Products.
7. **Taxes.** All taxes, duties and other governmental charges (other than general real property and income taxes), including any interest or penalties thereon, imposed directly or indirectly on Omron or required to be collected directly or indirectly by Omron for the manufacture, production, sale, delivery, importation, consumption or use of the Products sold hereunder (including customs duties and sales, excise, use, turnover and license taxes) shall be charged to and remitted by Buyer to Omron.
8. **Financial.** If the financial position of Buyer at any time becomes unsatisfactory to Omron, Omron reserves the right to stop shipments or require satisfactory security or payment in advance. If Buyer fails to make payment or otherwise comply with these Terms or any related agreement, Omron may (without liability and in addition to other remedies) cancel any unshipped portion of Products sold hereunder and stop any Products in transit until Buyer pays all amounts, including amounts payable hereunder, whether or not then due, which are owing to it by Buyer. Buyer shall in any event remain liable for all unpaid accounts.
9. **Cancellation; Etc.** Orders are not subject to rescheduling or cancellation unless Buyer indemnifies Omron against all related costs or expenses.
10. **Force Majeure.** Omron shall not be liable for any delay or failure in delivery resulting from causes beyond its control, including earthquakes, fires, floods, strikes or other labor disputes, shortage of labor or materials, accidents to machinery, acts of sabotage, riots, delay in or lack of transportation or the requirements of any government authority.
11. **Shipping; Delivery.** Unless otherwise expressly agreed in writing by Omron:
 - a. Shipments shall be by a carrier selected by Omron; Omron will not drop ship except in "break down" situations.
 - b. Such carrier shall act as the agent of Buyer and delivery to such carrier shall constitute delivery to Buyer;
 - c. All sales and shipments of Products shall be FOB shipping point (unless otherwise stated in writing by Omron), at which point title and risk of loss shall pass from Omron to Buyer; provided that Omron shall retain a security interest in the Products until the full purchase price is paid;
 - d. Delivery and shipping dates are estimates only; and
 - e. Omron will package Products as it deems proper for protection against normal handling and extra charges apply to special conditions.
12. **Claims.** Any claim by Buyer against Omron for shortage or damage to the Products occurring before delivery to the carrier must be presented in writing to Omron within 30 days of receipt of shipment and include the original transportation bill signed by the carrier noting that the carrier received the Products from Omron in the condition claimed.
13. **Warranties.** (a) **Exclusive Warranty.** Omron's exclusive warranty is that the Products will be free from defects in materials and workmanship for a period of twelve months from the date of sale by Omron (or such other period expressed in writing by Omron). Omron disclaims all other warranties, express or implied. (b) **Limitations.** OMRON MAKES NO WARRANTY OR REPRESENTATION, EXPRESS OR IMPLIED, ABOUT NON-INFRINGEMENT, MERCHANTABILITY OR FITNESS FOR A PARTICULAR PURPOSE OF THE PRODUCTS. BUYER ACKNOWLEDGES THAT IT ALONE HAS DETERMINED THAT THE PRODUCTS WILL SUITABLY MEET THE REQUIREMENTS OF THEIR INTENDED USE. Omron further disclaims all warranties and responsibility of any type for claims or expenses based on infringement by the Products or otherwise of any intellectual property right. (c) **Buyer Remedy.** Omron's sole obligation hereunder shall be, at Omron's election, to (i) replace (in the form originally shipped with Buyer responsible for labor charges for removal or replacement thereof) the non-complying Product, (ii) repair the non-complying Product, or (iii) repay or credit Buyer an amount equal to the purchase price of the non-complying Product; provided that in no event shall Omron be responsible for warranty, repair, indemnity or any other claims or expenses regarding the Products unless Omron's analysis confirms that the Products were properly handled, stored, installed and maintained and not subject to contamination, abuse, misuse or inappropriate modification. Return of any Products by Buyer must be approved in writing by Omron before shipment. Omron Companies shall not be liable for the suitability or unsuitability or the results from the use of Products in combination with any electrical or electronic components, circuits, system assemblies or any other materials or substances or environments. Any advice, recommendations or information given orally or in writing, are not to be construed as an amendment or addition to the above warranty. See <http://www.omron247.com> or contact your Omron representative for published information.
14. **Limitation on Liability; Etc.** OMRON COMPANIES SHALL NOT BE LIABLE FOR SPECIAL, INDIRECT, INCIDENTAL, OR CONSEQUENTIAL DAMAGES, LOSS OF PROFITS OR PRODUCTION OR COMMERCIAL LOSS IN ANY WAY CONNECTED WITH THE PRODUCTS, WHETHER SUCH CLAIM IS BASED IN CONTRACT, WARRANTY, NEGLIGENCE OR STRICT LIABILITY. Further, in no event shall liability of Omron Companies exceed the individual price of the Product on which liability is asserted.
15. **Indemnities.** Buyer shall indemnify and hold harmless Omron Companies and their employees from and against all liabilities, losses, claims, costs and expenses (including attorney's fees and expenses) related to any claim, investigation, litigation or proceeding (whether or not Omron is a party) which arises or is alleged to arise from Buyer's acts or omissions under these Terms or in any way with respect to the Products. Without limiting the foregoing, Buyer (at its own expense) shall indemnify and hold harmless Omron and defend or settle any action brought against such Companies to the extent based on a claim that any Product made to Buyer specifications infringed intellectual property rights of another party.
16. **Property; Confidentiality.** Any intellectual property in the Products is the exclusive property of Omron Companies and Buyer shall not attempt to duplicate it in any way without the written permission of Omron. Notwithstanding any charges to Buyer for engineering or tooling, all engineering and tooling shall remain the exclusive property of Omron. All information and materials supplied by Omron to Buyer relating to the Products are confidential and proprietary, and Buyer shall limit distribution thereof to its trusted employees and strictly prevent disclosure to any third party.
17. **Export Controls.** Buyer shall comply with all applicable laws, regulations and licenses regarding (i) export of products or information; (ii) sale of products to "forbidden" or other proscribed persons; and (iii) disclosure to non-citizens of regulated technology or information.
18. **Miscellaneous.** (a) **Waiver.** No failure or delay by Omron in exercising any right and no course of dealing between Buyer and Omron shall operate as a waiver of rights by Omron. (b) **Assignment.** Buyer may not assign its rights hereunder without Omron's written consent. (c) **Law.** These Terms are governed by the law of the jurisdiction of the home office of the Omron company from which Buyer is purchasing the Products (without regard to conflict of law principles). (d) **Amendment.** These Terms constitute the entire agreement between Buyer and Omron relating to the Products, and no provision may be changed or waived unless in writing signed by the parties. (e) **Severability.** If any provision hereof is rendered ineffective or invalid, such provision shall not invalidate any other provision. (f) **Setoff.** Buyer shall have no right to set off any amounts against the amount owing in respect of this invoice. (g) **Definitions.** As used herein, "including" means "including without limitation"; and "Omron Companies" (or similar words) mean Omron Corporation and any direct or indirect subsidiary or affiliate thereof.

Certain Precautions on Specifications and Use

1. **Suitability of Use.** Omron Companies shall not be responsible for conformity with any standards, codes or regulations which apply to the combination of the Product in the Buyer's application or use of the Product. At Buyer's request, Omron will provide applicable third party certification documents identifying ratings and limitations of use which apply to the Product. This information by itself is not sufficient for a complete determination of the suitability of the Product in combination with the end product, machine, system, or other application or use. Buyer shall be solely responsible for determining appropriateness of the particular Product with respect to Buyer's application, product or system. Buyer shall take application responsibility in all cases but the following is a non-exhaustive list of applications for which particular attention must be given:
 - (i) Outdoor use, uses involving potential chemical contamination or electrical interference, or conditions or uses not described in this document.
 - (ii) Use in consumer products or any use in significant quantities.
 - (iii) Energy control systems, combustion systems, railroad systems, aviation systems, medical equipment, amusement machines, vehicles, safety equipment, and installations subject to separate industry or government regulations.
 - (iv) Systems, machines and equipment that could present a risk to life or property. Please know and observe all prohibitions of use applicable to this Product.

NEVER USE THE PRODUCT FOR AN APPLICATION INVOLVING SERIOUS RISK TO LIFE OR PROPERTY OR IN LARGE QUANTITIES WITHOUT ENSURING THAT THE SYSTEM AS A WHOLE HAS BEEN DESIGNED TO ADDRESS THE RISKS, AND THAT THE OMRON'S PRODUCT IS PROPERLY RATED AND INSTALLED FOR THE INTENDED USE WITHIN THE OVERALL EQUIPMENT OR SYSTEM.
2. **Programmable Products.** Omron Companies shall not be responsible for the user's programming of a programmable Product, or any consequence thereof.
3. **Performance Data.** Data presented in Omron Company websites, catalogs and other materials is provided as a guide for the user in determining suitability and does not constitute a warranty. It may represent the result of Omron's test conditions, and the user must correlate it to actual application requirements. Actual performance is subject to the Omron's Warranty and Limitations of Liability.
4. **Change in Specifications.** Product specifications and accessories may be changed at any time based on improvements and other reasons. It is our practice to change part numbers when published ratings or features are changed, or when significant construction changes are made. However, some specifications of the Product may be changed without any notice. When in doubt, special part numbers may be assigned to fix or establish key specifications for your application. Please consult with your Omron's representative at any time to confirm actual specifications of purchased Product.
5. **Errors and Omissions.** Information presented by Omron Companies has been checked and is believed to be accurate; however, no responsibility is assumed for clerical, typographical or proofreading errors or omissions.

Complete "Terms and Conditions of Sale" for product purchase and use are on Omron's website at www.omron247.com – under the "About Us" tab, in the Legal Matters section.

ALL DIMENSIONS SHOWN ARE IN MILLIMETERS.

To convert millimeters into inches, multiply by 0.03937. To convert grams into ounces, multiply by 0.03527.

OMRON[®]**OMRON ELECTRONICS LLC**

1 Commerce Drive
Schaumburg, IL 60173
Tel: 847.843.7900

For U.S. technical support or other
inquiries: 800.556.6766

OMRON CANADA, INC.

885 Milner Avenue
Toronto, Ontario M1B 5V8
Tel: 416.286.6465

MEXICO SALES OFFICES

Mexico, D.F. 555.660.3144
Ciudad Juárez 656.623.7083
Monterrey, N.L. 818.377.4281
Querétaro 442.135.4510

BRAZIL SALES OFFICE

Sao Paulo 55.11.2101.6310

ARGENTINA SALES OFFICE

Cono Sur 54.114.787.1129

CHILE SALES OFFICE

Santiago 562.206.4592

OTHER LATIN AMERICAN SALES

mela@omron.com

OMRON ON-LINE**Global -**

www.omron.com

USA -

www.omron247.com

Canada -

www.omron.ca

Brazil -

www.omron.com.br

Latin America -

www.espanol.omron.com